

DORMER PRAMET

CATALOGO
KATALOG
CATALOGUS
CATALOGUE

2019



A	A976	102	C837	479	E282	319	EP10	275	H858	21	P707	508	S262	426
A002	A977	102	C907	456	E286	305	EP10TIN	275	H860	24	P709	510	S264	421
A002S	A978	102	C908	466	E287	295	EP11	275	H861	24	P711	512	S501	436
A022	B		C920	457	E288	285	EP20	290	J		P713	514	S511	439
A080	B100	158	C922	463	E289	263	EP21	290	J200	205	P715	516	S521	423
A087	B101	176	C948	467	E290	269	EP30	300	J205	205	P721	520	S523	424
A088	B121	178	D		E291	263	EP31	300	J210	206	P801	501	S524	422
A089	B122	166	D200	485	E292	263	EP40	321	J215	206	P801C	501	S525	417
A094	B157	173	D400	492	E293	264	EP41	321	J220	207	P803	503	S526	418
A095	B161	174	D402	493	E294	263	EX006G	252	J225	207	P803C	503	S527	419
A099	B170	170	D420	492	E295	265	EX006H	252	J235	208	P805	505	S529	433
A100	B180	168	D422	493	E296	265	EX00TIN	252	J245	209	P805C	505	S531	434
A101	B301	163	D745	486	E297	243	EX016H	252	J260	211	P807	507	S533	435
A108	B334	160	D747	488	E298	254	EX10	280	J280	210	P807C	507	S534	437
A110	B335	161	D750	491	E299	277	EX10TIN	280	K		P809	509	S535	438
A117	B400	152	D751	491	E300	282	EX11	280	K100	536	P811	511	S536	429
A119	B411	156	D752	490	E303	239	EX20	292	K101	536	P811C	511	S610	404
A120	B441	155	D753	490	E382	324	EX21	292	K102	536	P813	513	S611	405
A122	B442	157	D763	485	E383	283	EX30	302	K103	537	P813C	513	S612	410
A123	B481	153	E		E384	278	EX31	302	K104	537	P815	515	S629	440
A124	B901	162	E000	247	E390	234	EX40	323	K200	538	P815C	515	S637	402
A125	B903	164	E000TIN	247	E412	255	EX41	323	K201	538	P817	517	S638	403
A130	B952	165	E001	247	E414	258	F		K202	538	P819	518	S710	396
A147	B953	167	E002	260	E422	249	F100	355	K203	538	P821	519	S713	398
A160	B954	179	E002TIN	260	E423	249	F108	355	K204	538	P821C	519	S714	400
A166	B955	180	E003	260	E471	246	F110	356	K300	533	P823	521	S715	401
A170	B956	181	E011	279	E472	246	F120	357	K301	533	P825	522	S716	409
A188	B957	182	E013	284	E473	259	F130	358	K302	533	P831	502	S717	413
A190	C		E021	291	E474	259	F140	359	K303	533	P833	504	S718	414
A191	C110	443	E023	293	E500	235	F150	360	K304	533	P835	506	S739	441
A199	C122	454	E031	301	E501	235	F170	361	K305	533	P837	508	S740	441
A200	C123	445	E033	303	E504	235	F180	362	K310	534	P841	512	S761	415
A201	C126	443	E041	322	E513	271	F190	363	K311	534	P842	520	S763	425
A205	C135	447	E043	325	E515	288	F201	355	K312	534	P843	523	S765	420
A206	C139	445	E100	230	E524	298	F202	369	K313	534	P844	524	S766	416
A210	C159	451	E101	230	E531	308	F272	372	K314	534	P880	525	S767	428
A225	C167	453	E102	230	E533	311	F300	364	K330	535	P890	526	S802HA	390
A237	C246	458	E105	266	E534	310	F302	370	K520	539	R		S802HB	390
A238	C247	458	E108	286	E536	312	F310	365	K521	540	R100	30	S803HA	393
A242	C273	460	E111	296	E538	314	F312	371	K522	541	R120	28	S803HB	393
A243	C295	460	E115	307	E539	313	F320	366	L		R122	26	S804HA	406
A244	C299	456	E119	318	E542	315	F330	367	L000	342	R123	26	S804HB	406
A266	C305	450	E200	232	E544	317	F370	368	L001	343	R200	25	S812HA	391
A295	C306	448	E201	234	E545	316	G		L002	344	R453	40	S812HB	391
A296	C333	462	E207	250	E547	320	G106	189	L110	348	R454	40	S813HA	394
A345	C336	452	E212	250	E550	328	G107	192	L112	349	R457	36	S813HB	394
A350	C346	455	E216	249	E570	306	G125	198	L113	339	R458	36	S814HA	408
A400	C352	450	E225	287	E600	240	G129	187	L114	340	R459	44	S814HB	408
A402	C353	448	E229	297	E605	262	G132	194	L115	341	R463	50	S822	392
A405	C367	449	E237	232	E606	248	G135	184	L119	337	R467	47	S823	395
A412	C400	468	E238	257	E610	240	G136	189	L120	345	R510	34	S902	397
A413	C403	469	E239	257	E620	326	G137	185	L126	338	R520	32	S903	399
A510	C407	466	E240	245	E621	327	G138	195	M		R6011	26	S904	412
A520	C413	468	E241	245	E650	261	G142	191	M150	542	R7131	27	S922	397
A530	C428	464	E242	269	E651	294	G149	188	M151	543	R950	18	S933	399
A553	C492	465	E243	336	E653	332	G154	186	M152	544	R960	18	S944	412
A620	C500	470	E250	232	E654	304	G171	196	M200	545	R970	18	S991	442
A720	C505	471	E251	232	E708	335	G236	199	P		S		T	
A723	C700	484	E252	234	E709	334	G314	197	P601	502	S216	411	T200	226
A730	C710	483	E255	244	E710	330	G335	184	P605	506	S217	413	T201	226
A777	C800	472	E256	244	E711	331	G338	195	P607	508	S218	414	T205	228
A900	C801	475	E258	250	E712	333	G400	183	P609	510	S219	407	T206	228
A901	C810	473	E260	256	E714	329	G506	189	P611	512	S225	417	T210	226
A920	C820	477	E261	256	E720	334	G560	189	P613	514	S226	418	T215	229
A921	C822	476	E263	250	E721	330	G570	191	P615	516	S227	419		
A940	C825	474	E266	249	EP006G	241	G600	193	P621	520	S229	430		
A941	C830	481	E268	269	EP006H	241	H		P701	502	S231	431		
A951	C831	482	E275	287	EP00TIN	241	H853	21	P703	504	S233	432		
A952	C835	480	E278	297	EP016H	241	H855	21	P705	506	S260	415		

003 - 142



143 - 200



201 - 212

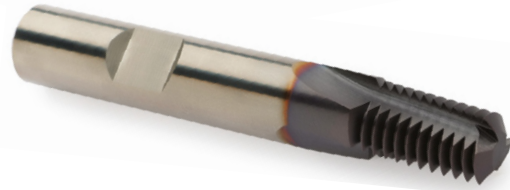

213 - 350



351 - 372



373 - 494



495 - 526



527 - 546

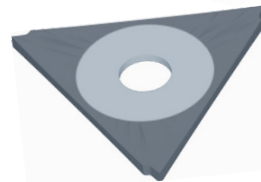

547 - 640

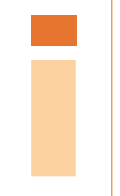

003 - 142



A002	69	A166	111	A405	120	H855	21
A002S	69	A170	80	A412	121	H858	21
A022	57	A188	140	A413	122	H860	24
A080	137	A190	138	A510	83	H861	24
A087	132	A191	139	A520	61	R100	30
A088	130	A199	136	A530	105	R120	28
A089	134	A200	123	A553	86	R122	26
A094	133	A201	125	A620	57	R123	26
A095	131	A205	123	A720	65	R200	25
A099	135	A206	123	A723	53	R453	40
A100	69	A210	124	A730	105	R454	40
A101	69	A225	126	A777	76	R457	36
A108	76	A237	127	A900	88	R458	36
A110	92	A238	128	A901	88	R459	44
A117	57	A242	129	A920	66	R463	50
A119	55	A243	91	A921	66	R467	47
A120	57	A244	91	A940	95	R510	34
A122	54	A266	123	A941	95	R520	32
A123	56	A295	141	A951	116	R6011	26
A124	64	A296	142	A952	116	R7131	27
A125	98	A345	114	A976	102	R950	18
A130	105	A350	112	A977	102	R960	18
A147	76	A400	118	A978	102	R970	18
A160	82	A402	119	H853	21		

Materiale	Material	Materiaal	Matière
Normativa	Standard	Norm	Standard
Profondità	Bohrtiefe ohne zu entspannen	Diepte	Profondeur
Angolo al vertice	Spitzenwinkel	Punthoek	Affûtage
Trattamento superficiale	Oberfläche	Oppervlaktebehandeling	Revêtement
Codolo	Schaft	Schacht	Queue
Senso di rotazione	Schneidrichtung	Draairichting	Direction
Lubrificazione	Kühlung	Koeling	Lubrification
<ul style="list-style-type: none"> ■ Raccomandato ● Accettabile 	Sehr gut für die Anwendung	Uitstekend voor deze toepassing	Excellent pour les applications
Esempio 10 = Velocità periferica in m/min +/- 10%	Gut für die Anwendung	Acceptabel voor deze toepassing	Acceptable pour les applications
	Beispiel 10 = Schnittgeschwindigkeit (m/min) +/- 10 %	Voorbeeld 10 = snijsnelheid in m/min +/-10%	Exemple 10 = Vitesse périphérique en mètres/minute +/- 10%
Codice prodotto	Produktbezeichnung	Productcode	Codes
Gamma diametri	Durchmesserbereich	Diameterreeks	Gamme de diamètres

AMG	Italiano	Deutsch	Nederlands	Français
1.1	Acciaio dolce magnetico	Magnetweicheisen	Automatenstaal, zachtstaal	Acier doux magnétique
1.2	Acciaio da costruzione e da cementazione	Baustahl, Einsatzstahl	Constructiestaal, inzetstaal	Acier de construction, Acier de cémentation
1.3	Acciaio al carbonio	Kohlenstoffstahl	Koolstofstaal	Acier au carbone ordinaire
1.4	Acciaio legato	Legierter Stahl	Gelegeerd staal	Acier allié
1.5	Acciaio legato / Acciaio bonificato e temprato	Legierter und vergüteter Stahl	Gelegeerd en veredeld staal	Acier allié/ Acier trempé et revenu
1.6	Acciaio legato / Acciaio bonificato e temprato	Legierter und vergüteter Stahl	Hooggelegeerd veredeld staal	Acier allié/ Acier trempé et revenu
1.7	Acciaio legato/temprato	Legierter gehärteter Stahl	Gelegeerd en gehard staal	Acier allié trempé
1.8	Acciaio legato/temprato	Legierter gehärteter Stahl	Gelegeerd en gehard staal	Acier allié trempé
2.1	Acciaio inossidabile/automatico	Rostfreier Stahl, geschwefelt	Roestvast automatenstaal	Acier inoxydable de décolletage
2.2	Austenitico	Austenitisch	Austenitisch	Austénitique
2.3	Ferritico+Austenitico, Martensitico	Ferritisch+Austenitisch, Martensitisch	Ferritisch+Austenitisch, Martensitisch	Ferritique + Austénitique, Martensitique
2.4	Acciai inossidabili con indurimento da precipitazione	Vergüteter rostfreier Stahl	Precipitatiehardend roestvast staal	Acier inoxydable Trempé
3.1	Ghisa con grafite lamellare	Grauguss	Gietijzer Lamellair	Graphite lamellaire
3.2	Ghisa con grafite lamellare	Vergüteter Grauguss	Gietijzer Lamellair	Graphite lamellaire
3.3	Ghisa malleabile con grafite sferoidale	Kugelgraphitguss, Temperguss	Nodulair gietijzer / Smeedbaar gietijzer	Graphite nodulaire/ Fonte malléable
3.4	Ghisa malleabile con grafite sferoidale	Kugelgraphitguss, Temperguss	Nodulair gietijzer / Smeedbaar gietijzer	Graphite nodulaire/ Fonte malléable
4.1	Titanio non legato	Reintitan	Titaan, ongelegeerd	Titane, non-allié
4.2	Leghe di titanio	Titan-Legierungen	Titaan, gelegeerd	Titane, allié
4.3	Leghe di titanio	Titan-Legierungen	Titaan, gelegeerd	Titane, allié
5.1	Nichel non legato	Reinnickel	Nikkel, ongelegeerd	Nickel, non-allié
5.2	Leghe di nichel	Nickel-Legierungen	Nikkel, gelegeerd	Nickel, allié
5.3	Leghe di nichel	Nickel-Legierungen	Nikkel, gelegeerd	Nickel, allié
6.1	6.1 Rame	Kupfer	Koper	Cuivre
6.2	β-Ottone, Bronzo	Kurzspanendes Messing, Bronze	β-Messing, brons	β-Laiton, Bronze
6.3	α-Ottone	Langspanendes Messing	α-Messing	α-Laiton
6.4	Bronzo ad alta resistenza	Cu-Al-Fe-Legierung, (Amppo)	Extra-sterk brons	Bronze, haute résistance
7.1	Al, Mg, non legato	Al, Mg, unlegiert	Al, Mg, ongelegeerd	Al, Mg, non-allié
7.2	Leghe di Al, Si < 0.5%	Al legiert, Si<0.5 %	Al gelegeerd, Si < 0.5%	Al allié, Si < 0.5%
7.3	Leghe di Al, Si > 0.5% < 10%	Al legiert, Si>0.5 %<10 %	Al gelegeerd, Si > 0.5% < 10%	Al allié, Si > 0.5% < 10%
7.4	Leghe di Al, Si > 10% Rinforzate Whisker Leghe di Al, Leghe di Mg	Al legiert, Si>10 % Whisker verstärkte Al-Legierung, Mg-Legierung	Al gelegeerd, Si>10% whisker versterkt Al-legeringen, Mg-legeringen	Al allié, Si>10% Alliages d'Al ou Mg, céramique renforcée
8.1	Materiali termoplastici	Thermoplaste	Thermoplasten	Thermoplastiques
8.2	Materiali plastici termoidurenti	Duroplaste	Duraplasten	Plastiques thermodurcissables
8.3	Materiali plastici rinforzati	Faserverstärkte Kunststoffe	Verstärkte kunststofmaterialen	Plastiques renforcés
9.1	Cermets (materiali metallo-ceramici)	Cermets (Metallkeramik)	Cermets (metal-ceramics)	Cermets (céramiques métalliques)
10.1	Grafite standard	Graphit	Standaard Grafiet	Graphite standard

	HM	HM	HM	HSS	HSS	HSS			
				3XD	5XD	8XD			
	R950	R960	R970	H853	H855	H858	H860	H861	
	15/32 - 42.00	15/32 - 30.50	15/32 - 42.00	12.00 - 42.50	12.00 - 42.50	14.00 - 42.50	N1 - N7	N1 - N6	
AMG	18	18	18	21	21	21	24	24	ISO
1.1	●110W	■110W							P 1
1.2	●100W	■100W							P 1
1.3	■100W								P 2
1.4	■85W								P 3
1.5	■85W								P 4
1.6	■60T								H 1
1.7									H 3
1.8									H 4
2.1		■60V							M 1
2.2		■50T							M 3
2.3		■40T							M 2
2.4	●35T	●35T							S 2
3.1		■120V	■120V						K 1
3.2		■116V	■116V						K 2
3.3	■88V	●88V	■80V						K 3
3.4	■88V	●88V	■80V						K 4
4.1		●45T							S 1
4.2		●35T							S 2
4.3		●30S							S 3
5.1		●35T							S 1
5.2		●30S							S 2
5.3		●25S							S 3
6.1									N 3
6.2									N 4
6.3									N 3
6.4									N 4
7.1									N 1
7.2									N 1
7.3									N 1
7.4									N 2
8.1									O
8.2									O
8.3									O
9.1									H
10.1									O

Materiale	Material	Materiaal	Matière
Normativa	Standard	Norm	Standard
Profondità	Bohrtiefe ohne zu entspannen	Diepte	Profondeur
Angolo al vertice	Spitzenwinkel	Punthoek	Affûtage
Trattamento superficiale	Oberfläche	Oppervlakbehandeling	Revêtement
Codolo	Schaft	Schacht	Queue
Forma	Form	Uitvoering	Forme
Senso di rotazione	Schneidrichtung	Draairichting	Direction
Lubrificazione	Kühlung	Koeling	Lubrification
Angolo di svasatura	Senkwinkel	Verzinkhoek	° d'épaulement
■ Raccomandato	Sehr gut für die Anwendung	Uitstekend voor deze toepassing	Excellent pour les applications
● Accettabile	Gut für die Anwendung	Acceptabel voor deze toepassing	Acceptable pour les applications
Esempio 10 = Velocità periferica in m/min +/- 10%	Beispiel 10 = Schnittgeschwindigkeit (m/min) +/- 10 %	Voorbeeld 10 = snijnsnelheid in m/min +/-10%	Exemple 10 = Vitesse périphérique en mètres/ minute +/- 10%
Codice prodotto	Produktbezeichnung	Productcode	Codes
Gamma diametri	Durchmesserbereich	Diameterreeks	Gamme de diamètres









AMG	Italiano	Deutsch	Nederlands	Français
1.1	Acciaio dolce magnetico	Magnetweicheisen	Automatenstaal, zachtstaal	Acier doux magnétique
1.2	Acciaio da costruzione e da cementazione	Baustahl, Einsatzstahl	Constructiestaal, inzetstaal	Acier de construction, Acier de cémentation
1.3	Acciaio al carbonio	Kohlenstoffstahl	Koolstofstaal	Acier au carbone ordinaire
1.4	Acciaio legato	Legierter Stahl	Gelegeerd staal	Acier allié
1.5	Acciaio legato / Acciaio bonificato e temprato	Legierter und vergüteter Stahl	Gelegeerd en veredeld staal	Acier allié/ Acier trempé et revenu
1.6	Acciaio legato / Acciaio bonificato e temprato	Legierter und vergüteter Stahl	Hoogelegeerd veredeld staal	Acier allié/ Acier trempé et revenu
1.7	Acciaio legato/temprato	Legierter gehärteter Stahl	Gelegeerd en gehard staal	Acier allié trempé
1.8	Acciaio legato/temprato	Legierter gehärteter Stahl	Gelegeerd en gehard staal	Acier allié trempé
2.1	Acciaio inossidabile/automatico	Rostfreier Stahl, geschwefelt	Roestvast automatenstaal	Acier inoxydable de décolletage
2.2	Austenitico	Austenitisch	Austenitisch	Austénitique
2.3	Ferritico+Austenitico, Martensitico	Ferritisch+Austenitisch, Martensitisch	Ferritisch+Austenitisch, Martensitisch	Ferritique + Austénitique, Martensitique
2.4	Acciai inossidabili con indurimento da precipitazione	Vergüteter rostfreier Stahl	Precipitatiehardend roestvast staal	Acier inoxydable Trempé
3.1	Ghisa con grafite lamellare	Grauguss	Gietijzer Lamellair	Graphite lamellaire
3.2	Ghisa con grafite lamellare	Vergüteter Grauguss	Gietijzer Lamellair	Graphite lamellaire
3.3	Ghisa malleabile con grafite sferoidale	Kugelgraphitguss, Temperguss	Nodulair gietijzer / Smeedbaar gietijzer	Graphite nodulaire/ Fonte malléable
3.4	Ghisa malleabile con grafite sferoidale	Kugelgraphitguss, Temperguss	Nodulair gietijzer / Smeedbaar gietijzer	Graphite nodulaire/ Fonte malléable
4.1	Titanio non legato	Reintitan	Titaan, ongelegeerd	Titane, non-allié
4.2	Leghe di titanio	Titan-Legierungen	Titaan, gelegeerd	Titane, allié
4.3	Leghe di titanio	Titan-Legierungen	Titaan, gelegeerd	Titane, allié
5.1	Nichel non legato	Reinnickel	Nikkel, ongelegeerd	Nickel, non-allié
5.2	Leghe di nichel	Nickel-Legierungen	Nikkel, gelegeerd	Nickel, allié
5.3	Leghe di nichel	Nickel-Legierungen	Nikkel, gelegeerd	Nickel, allié
6.1	6.1 Rame	Kupfer	Koper	Cuivre
6.2	β-Ottone, Bronzo	Kurzspanendes Messing, Bronze	β-Messing, brons	β-Laiton, Bronze
6.3	α-Ottone	Langspanendes Messing	α-Messing	α-Laiton
6.4	Bronzo ad alta resistenza	Cu-Al-Fe-Legierung, (Ampco)	Extra-sterk brons	Bronze, haute résistance
7.1	Al, Mg, non legato	Al, Mg, unlegiert	Al, Mg, ongelegeerd	Al, Mg, non-allié
7.2	Leghe di Al, Si < 0.5%	Al legiert, Si<0.5 %	Al gelegeerd, Si < 0.5%	Al allié, Si < 0.5%
7.3	Leghe di Al, Si > 0.5% < 10%	Al legiert, Si>0.5 %<10 %	Al gelegeerd, Si > 0.5% < 10%	Al allié, Si > 0.5% < 10%
7.4	Leghe di Al, Si > 10% Rinforzate Whisker Leghe di Al, Leghe di Mg	Al legiert, Si>10 % Whisker verstärkte Al-Legierung, Mg-Legierung	Al gelegeerd, Si>10 % whisker versterkt Al-legeringen, Mg-legeringen	Al allié, Si>10 % Alliages d'Al ou Mg, céramique renforcée
8.1	Materiali termoplastici	Thermoplaste	Thermoplasten	Thermoplastiques
8.2	Materiali plastici termoindurenti	Duroplaste	Duraplasten	Plastiques thermodurcissables
8.3	Materiali plastici rinforzati	Faserverstärkte Kunststoffe	Versterkte kunststofmaterialen	Plastiques renforcés
9.1	Cermets (materiali metallo-ceramici)	Cermets (Metallkeramik)	Cermets (metal-ceramics)	Cermets (céramiques métalliques)
10.1	Grafite standard	Graphit	Standaard Grafiet	Graphite standard

	HM	HM	HSS-E	HSS	HSS	HSS	HSS	HSS	HSS-E	HSS-E	HSS	HSS HM	HSS-E	HSS-E	HSS-E	
	DIN 6537 K	DIN 6537 L	DORMER	DIN 1897	DIN 1897	DIN 1897	DIN 1897	DIN 1897	DIN ANSI	DIN 1897	DIN 1897	DIN 1897	DIN 1899	DIN 1899	DIN ANSI	DIN ANSI
	3XD	5XD	1XD	1XD	1.25XD	1.5XD	2.5XD	2.5XD	2.5XD	2.5XD	2.5XD	2.5XD	2.5XD	3XD	3XD	
	140°	140°		90° 120°	120°	120°	135°	135°	130°	135°	130°	118°	118°	130°	130°	
	TiAlN	TiAlN	Bronze		ST	ST	ST	TiN	Bronze	Bronze	TiN	ST			Alocrona Top	
	DIN 6535HA	DIN 6535HA														
	CTW™	CTW™	N	N	N	N	N	N	N	N		H	N	W	W	
	FORCE M	FORCE M									ADX				PFX	
	R467	R463	A723	A122	A119	A123	A120	A022	A620	A117	A520	A124	A720	A920	A921	
	3.00 - 16.00	3.00 - 16.00	6.00 - 8.00	6.00 - 20.00	3.30 - 5.10	3/32 - 1/4	0.50 - 25.00	0.50 - 16.00	2.50 - 13.00	1.00 - 13.00	3.00 - 13.00	3.00 - 16.00	0.15 - 1.40	1.00 - 20.00	2.50 - 16.00	
AMG	47	50	53	54	55	56	57	57	57	57	61	64	65	66	66	ISO
1.1			■35D	■35E	■35C	■35E	■35J	■35K	●38K	●38K	■57M		■35A	■40J	■60M	P 1
1.2			■30D	■30E	■27C	■30E	■30J	■32K	●33H	●33H	■47M		■30A	■34J	■52M	P 1
1.3			●25C	■27C	●23C	■27C	■27G	■25I	●30G	●30G	■40K		■27A	■32I	■53J	P 2
1.4			●20C	●21C	●20C	●21C	■21G	■23H	●27G	●27G	■32I		■23A	■32I	■53J	P 3
1.5				●14C	●8C	●14C	●14F	■16G	●18F	■18F	■21G	●40C	●17A	■23E	■38G	P 4
1.6				●10B	●7A	●10B	●10E	●10E	●11E	■11E	●11E	●37A	●10A	■19E	■30G	H 1
1.7																H 3
1.8																H 4
2.1	■85G	■85G		●16C	●15A	●16C	■16F	■15G	■22F	■22F	■30I		●22A	■15F	■17F	M 1
2.2	■75G	■75G		●9D	●7C	●9D	●9H	●8I	■11H	■11H	■16I	●35C	●10A	■7F	■9F	M 3
2.3	■60F	■60F		●10B	●10A	●10B	●10D	●9E	■15D	■15D	■20G	●35C	●15A	■9D	■11D	M 2
2.4	■60E	■60E														S 2
3.1				●32E			■32J	■32K	●34K	●34K	■48M	■55C	■30A	●34L	■53L	K 1
3.2				●27C			■27G	■25I	●30F	●30F	■37K	■43C	■24A	●26L	■42L	K 2
3.3				●20C			■20F	■20G	●22F	●22F	■30J	■40C	●20A	●26L	■42L	K 3
3.4				●16B			●16F	●16G	●17F	●17F	■26F	■32A	●14A	●19J	■36J	K 4
4.1	■55V	■55V		●27C	●27A	●27C	■27G	■25I	●30G	■30G	■34I	●40A	●23A	■30G	●48I	S 1
4.2	■45V	■45V		●12B	●12A	●12B	■16E	■14F	●18F	■18F	■20G	●35A	●17A	■18G	●29I	S 2
4.3	■40U	■40U		●7A	●7A	●7A	●8C	●8C	●10C	■10C	●4B	●25A	●8A	■10C	●16E	S 3
5.1	●55U	●55U		●13D	●9A	●13D	●13H	●13H	●15H	■15H	●17I	●30A	●10A	■15I	●24L	S 1
5.2	●45U	●45U		●8C	●4C	●8C	●8F	●8F	●9F	■9F	●11G	●25A	●7A	■9G	●14I	S 2
5.3	●40U	●40U		●4A	●3C	●4A	●4B	●4B	●6C	■6C	●7E	●20A	●4A	■6E	●10G	S 3
6.1				■27D	●27A	■27D	●36H	●36H	●38I	●38I	●40E		●35A	●65H		N 3
6.2				■33E	●33C	■33E	●38J	●38K	●40K	●40K	■50I	●70G	●40A	●66J		N 4
6.3				■27D	●27C	■27D	●27I	●27I	●27J	●27J	■45K	●60E	●35A	●40J	●71J	N 3
6.4				■16D	●16C	■16D	●16H	●16I	●16I	●16I	■20F	●50C	●27A	●31G	●50I	N 4
7.1				■33E	●33C	■33E	●33K	■40F	●40K	●35K	●55I		●35A	●75L		N 1
7.2				■30E	●30C	■30E	●30J	■32K	●35J	●33J	■50M		●30A	■45N		N 1
7.3				●30D	●30C	●30D	●30I	■32J	●32I	●31I	■37K		●27A	●40N		N 1
7.4				●25D	●25C	●25D	●25I	●25J	●30G	●30G	■35I		●27A	●36J	■48J	N 2
8.1				●30F	●30I	●30F	●30K	●30K	●40L	●35M	●65G		●48A	●55J		O
8.2				●35E	●35C	●35E	●35I	●35I	●32K	●28K	■50G	●60E	●25A	●40H		O
8.3				●17D		●17D	●17G	●17G	●18I	●17I	■35F					O
9.1				●12A		●12A	●4C	●4C		■6C		●9C				H
10.1																O

	HSS	HSS	HSS	HSS	HSS	HSS-E	HSS-E	HSS	HSS HM	HSS	HSS-E	HSS-E	HSS-E	HSS	HSS	HSS	
	DIN 338	DIN 338	DIN 338	DIN 338	DIN 338	DIN 338	DIN 338	DORMER	DIN 338	DIN 338	DORMER	DIN ANSI	DIN ANSI	NAS 907	NAS 907	DIN 340	
	4XD	4XD	4XD	4XD	4XD	6XD	4XD	4XD	4XD	4XD	5XD	6XD	6XD	4XD	4XD	6XD	
	118°	118°	118°	118°	135°	130°	135°	118°	118°	130°	130°	130°	130°	135°	118°	118°	
	TIN	TIN	ST	ST	ST		Bronze	ST	ST	TIN	TiAlN Top		Alcrona Top			ST	
											DIN 6535HA						
	N	N	N	N	W	VA	N	N	N			W	W	N	N	N	
								NAS 907J									
	002	002								ADX	ADX	PFX	PFX				
	A002	A002S	A100	A101	A108	A147	A777	A170	A160	A510	A553	A900	A901	A243	A244	A110	
	1.00 - 16.00	2.00 - 13.00	0.20 - 20.00	1.00 - 12.00	1.00 - 16.00	0.30 - 15.00	0.30 - 16.00	13.00 - 1.1/2	4.00 - 16.00	3.00 - 14.00	5.00 - 20.00	1.00 - 20.00	1.50 - 16.00	3/32 - 1/4	1/8 - 1/4	0.50 - 1"	
AMG	69	69	69	69	76	76	76	80	82	83	86	88	88	91	91	92	ISO
1.1	47J	47J	35H	35H	35I	35I	35J	35H	60E	57M	85L	38H	60J			27G	P 1
1.2	40J	40J	30H	30H	30I	30I	30H	30H	60E	47M	70L	33H	50J			25G	P 1
1.3	35F	35F	25F	25F	25G	25G	27G	25F	55D	40K	60L	26H	44I	25F	25F	20E	P 2
1.4	30F	30F	20F	20F	20F	20F	24F	20E	50D	30H	45H	26H	44I	20F	20F	16E	P 3
1.5	18F	18F	13E	13E	13E	13E	17E	13D	40C	21F	28F	21E	33G	13E	13E	9D	P 4
1.6	10E	10E	9D	9D	9D	9D	10D	9C	37A	11D	15D	16E	26G	9D	9D	6B	H 1
1.7																	H 3
1.8																	H 4
2.1	20F	20F	15E	15E	15E	15E	22E	15D	40B	28G	40G	15E	17E	15E	15E	10D	M 1
2.2	12G	12G	8G	8G	9G	9G	11G	7F	35C	14I	19I	7E	9E	8G	8G	6F	M 3
2.3	16C	16C	9C	9C	10D	10D	15C	7B	35A	19G	27G	9C	11C	9C	9C	4B	M 2
2.4							7B										S 2
3.1	40J	40J	30H	30H	30H	30H	35H	27H	50C	42K	70K	24J	58I	30I	30I	28H	K 1
3.2	30E	30E	24F	24F	24F	24F	28D	22E	40A	32J	50J	19J	47I	24F	24F	21E	K 2
3.3	28E	28E	20E	20E	20E	20E	22E	19D	35A	28J	45J	19J	34J	20E	20E	15D	K 3
3.4	26E	26E	14E	14E	14E	14E	17E	12D	30A	25F	42F	14I	28I	14E	14E	13D	K 4
4.1	23F	23F	23E	23E	25G	25G	28F	17E	35A	32G	45G	22E	35G	23F	23F	17E	S 1
4.2	13D	13D	12D	12D	16E	16E	20D	9C	35A	20H	30E	15E	24G	12D	12D	9C	S 2
4.3	7B	7B	6B	6B	7B	7B	11C	5A	25A	4B	8C	6C	10E	6B	6B	4A	S 3
5.1	13G	13G	10G	10G	12G	12G	15G	8F	30A	17I	25I	14G	22I	10G	10G	8F	S 1
5.2	7E	7E	6E	6E	7G	7G	7E	4D	25A	9E	15E	7G	11I	6E	6E	4D	S 2
5.3	3A	3A	3A	3A	6E	6E	6B	3A	20A	6E	10G	6C	10E	3A	3A	3A	S 3
6.1	50G	50G	33G	33G	33G	33G	38H	35F	55D	40D	70G	65G				30E	N 3
6.2	33I	33I	35I	35I	35I	35I	40F	33H	70G	50I	85I	53I				32H	N 4
6.3	39H	39H	27H	27H	31H	31H	27H	27G	60C	45I	80I	34H	56I	27H	27H	27G	N 3
6.4	30G	30G	16G	16G	16G	16G	21F	16F	50C	20F	35G	30G	48I	16G	16G	16E	N 4
7.1	41K	41K	33J	33J	33J	33J	33J	33I	50I	50G	70H	60J				32I	N 1
7.2	38J	38J	30I	30I	30I	30I	30I	30H	45H	50M	100M	45N				27H	N 1
7.3	33I	33I	27H	27H	27H	27H	27H	27G	40G	31I	55I	40N				27G	N 1
7.4	33I	33I	24F	24F	24F	24F	27F	22G	35F	33I	55J	28I	48I	24F	24F	25E	N 2
8.1	30I	30I	30J	30J	30J	30J		30I		65G	90G	55I				35I	O
8.2	50H	50H	28H	28H	28H	28H		28G	60E	50G		40G				26G	O
8.3	35F	35F	14F	14F	14F	14F		14E		35F						12E	O
9.1	3B	3B	3B	3B	3B	3B	6C	3A	9C					3B	3B	3A	H
10.1																	O

	HSS-E	HSS-E	HSS	HSS-E	HSS-E	HSS-E	HSS	HSS	HSS-E	HSS HM	HSS	HSS	HSS	HSS	HSS	
	DIN ANSI	DIN ANSI	BS 328	DIN 1869/1	DIN 1869/2	DIN 1869/3	DIN 345	DIN 345	DIN 345	DIN 345	DIN 341	DIN 1870/1	DIN 1870/1	DIN 1870/2	DIN 8374	
	10XD	10XD	10XD	15XD	20XD	25XD	4XD	4XD	4XD	4XD	6XD	10XD	15XD	20XD	4XD	
	130°	130°	118°	130°	130°	130°	118°	118°	118°	118°	118°	118°	130°	130°	118°	
		Alcrona Top	ST				ST	TIN	Bronze	ST	ST	ST	ST	ST	ST	
	W	W	N	W	W	W	N	N	N	N	N	N	W	W	N	
	PFX	PFX		PFX	PFX	PFX										
	A940	A941	A125	A976	A977	A978	A130	A530	A730	A166	A350	A345	A951	A952	A400	
	1.00 - 20.00	1.00 - 16.00	1.40 - 1"	1.50 - 14.00	1.50 - 14.00	3.00 - 10.00	3.00 - 50.80	8.50 - 40.00	10.00 - 32.00	10.00 - 33.00	5.00 - 50.00	8.00 - 40.00	10.00 - 30.00	8.00 - 40.00	M3 - M10	
AMG	95	95	98	102	102	102	105	105	105	111	112	114	116	116	118	ISO
1.1	■38F	■53G	■24E	●31C	●31B	●31A	■35I	■47I	●35J	●60E	■27I	■24G	■27G	■27G	■32G	P 1
1.2	■33F	■46G	■22E	●26C	●26B	●26A	■30I	■40I	●30H	●60E	■25I	■22G	■22G	■22G	■27G	P 1
1.3	■22G	■36G	●16C	■22C	■22B	■22A	■25F	■30F	●27G	●55D	■20G	●17E	■19E	■19E	■22E	P 2
1.4	■22G	■36G	●15C	■22C	■22B	■22A	■20F	■27F	●23F	●50D	●16F	●15D	●15D	●15D	■20E	P 3
1.5	■17C	■23D	●6A	■12A	■12A	■12A	●12E	●20E	■17E	●40C	●10E	●6C	●8C	●8C	●10C	P 4
1.6	■12C	■17D	●5A	■10A	■10A	■10A	●9D	●10D	■10D	●37A	●6D	●5B	●6B	●6B	●6C	H 1
1.7																H 3
1.8																H 4
2.1	■15C	■17C	●9C	●12B	●12B	●12A	●15E	●24E	●24E	●40B	●13E	●12C	●12C	●12C	●16E	M 1
2.2	■7E	■9E	●4E	●7C	●7B	●7A	●9G	●13G	■11G	●35C	●4G	●4E	●6E	●6E	●9G	M 3
2.3	■9B	■11B	●8A	●8A	●8A	●8A	●10C	●20C	■17C	●35A	●8C	●8A	●12A	●12A	●12C	M 2
2.4																S 2
3.1		■36I	●22G				■30I	●36I	●35J	■50C	●26I	●22G	●22G	●22G	■30G	K 1
3.2	●16I	■30I	●18D	●23C	●23B	●23A	■24E	■28E	●28G	■40C	●20F	●18D	●16D	●16D	■25E	K 2
3.3	●16I	■30I	●13C	●16C	●16B	●16A	■20E	■27E	●22E	■35C	●18E	●13C	●13C	●13C	●19E	K 3
3.4	●12H	■24H	●9C	●11A	●11A	●11A	●14E	●22E	■17E	■30A	●11E	●9C	●9C	●9C	●18C	K 4
4.1	■18E	●25F	●11D	●15C	●15B	●15A	●23F	●32F	●28G	●35A	●16F	●15D	●18D	●18D	●23E	S 1
4.2	■13C	●18D	●9B	●11A	●11A	●11A	●13D	●18D	●20D	●35A	●9D	●9B	●10B	●10B	●14C	S 2
4.3	■6C	●8D	●5A	●5A	●5A	●5A	●7B	●13B	●11C	●25A	●5B	●5A	●6A	●6A	●8A	S 3
5.1			●5E				●10G	●13G	●15G	●30A	●8G	●8E	●7E	●7E	●10G	S 1
5.2			●4C				●7E	●6E	●7E	●25A	●4E	●4C	●5C	●5C	●6C	S 2
5.3			●3A				●4A	●3A	●6B	●20A	●3A	●3A	●3A	●3A	●4A	S 3
6.1	●65F		●24D				●33F	●60G	●38L	●55D	●33F	●27D	●22D	●22D	●35E	N 3
6.2	●70F		●33G				●35I	●55I	●40J	●75G	●35I	●33G	●33G	●33G	●40E	N 4
6.3	●34G	●48H	●22F	●30D	●30C	●30B	●35H	■40G	●27H	●60C	●35H	●27F	●22F	●22F	●32E	N 3
6.4	●30G	●42H	●18D	●27D	●27C	●27B	●16F	●35E	●21F	●50C	●16F	●16D	●16D	●16D	●20E	N 4
7.1	●53H		●24H				●26J	●55I	●33J	●50I	●33J	●33H	●30H	●30H	●45E	N 1
7.2	■45N		●22G				●30I	●45I	●30I	●45H	●25I	●27G	●27G	●27G	●32E	N 1
7.3	●40N		●22F				●28H	●35G	●30H	●40G	●27H	●27F	●24F	●24F	●32E	N 1
7.4	●30G	■42H	●20E	●27D	●27C	●27B	●23H	●28G	●27F	●35F	●25H	●24F	●22F	●22F	●25E	N 2
8.1	●55H		●30H				●30K	●50J	●35K		●35L	●30J	●30J	●30J	●30I	O
8.2	●40F		●26F				●28J	●50H	●28J	●60E	●26J	●30H	●30H	●30H		O
8.3			●10D				●14H	●35F	●20H		●12H	●10F	●10F	●10F		O
9.1			●3A				●3B	●3B	●5C	●9C	●3B	●3A	●3A	●3A		H
10.1																O

	HSS	HSS	HSS	HSS	HSS	HSS	HSS-E	HSS-E	HSS	HSS	HSS	HSS-E	HSS-E	HSS-E	
	DIN 8376	DIN 8377	DORMER	DORMER	DIN 333A	DIN 333A	DIN 333A	DIN 333A	DIN 333R	DORMER	BS 328	DIN 333A	DIN 333R	DORMER	
	4XD	4XD	2.5XD	2.5XD	1XD	1XD	1XD	1XD	1XD	1XD	1XD	1XD	1XD	1XD	
	118°	118°	118°	118°	118°	118°	118°	118°	118°	122°	120°	118°	118°	118°	
	ST	ST	ST	ST		TIN		TiAlN							
	N	N													
	180°	180°	90°	180°	60°	60°	60°	60°	60°	60°	60°	60°	60°	60°	
	A402	A405	A412	A413	A200	A205	A206	A266	A210	A201	A225	A237	A238	A242	
	M3 - M10	M6 - M18	M3 - M10	M3 - M10	0.50 - 12.50	1.00 - 5.00	1.00 - 5.00	1.00 - 5.00	0.50 - 10.00	0.63 - 6.00	3/64 - 5/16	1.60 - 10.00	1.60 - 8.00	1.00 - 5.00	
AMG	119	120	121	122	123	123	123	123	124	125	126	127	128	129	ISO
1.1	■32G	■32G	■32I	■32I	■35I	■42I	■42I	■42I	■35I	■35I	■35I	■35I	■35I	■35I	P 1
1.2	■27G	■27G	■27I	■27I	■30I	■36I	■36I	■36I	■30I	■30I	■30I	■30I	■30I	■30I	P 1
1.3	■22E	■22E	■22G	■22G	■25G	■30G	■30G	■30G	■25G	■25G	■25G	■25G	■25G	■25G	P 2
1.4	■20E	■20E	■20G	■20G	■20F	■24F	■24F	■24F	■20F	■20F	■20F	■20F	■20F	■20F	P 3
1.5	●10C	●10C	●10E	●10E	●13E	●16E	●16E	●16E	●10E	●13E	●13E	●13E	●13E	●13E	P 4
1.6	●6C	●6C	●6C	●6C	●9D	●11D	●11D	●11D	●9D	●9D	●9D	●9D	●9D	●9D	H 1
1.7															H 3
1.8															H 4
2.1	●16E	●16E	■16G	■16G	●15E	●18E	●18E	●18E	●15E	●15E	●15E	●15E	●15E	●15E	M 1
2.2	●9G	●9G	●9I	●9I	●8G	●10G	●10G	●10G	●8G	●8G	●8G	●8G	●8G	●8G	M 3
2.3	●12C	●12C	●12E	●12E	●10C	●12C	●12C	●12C	●10C	●10C	●10C	●10C	●10C	●10C	M 2
2.4															S 2
3.1	■30G	■30G	■30G	■30G	■30I	■36I	■36I	■36I	■30I	■30I	■30I	■30I	■30I	■30I	K 1
3.2	■25E	■25E	■25E	■25E	■24F	■29F	■29F	■29F	■24F	■24F	■24F	■24F	■24F	■24F	K 2
3.3	●19E	●19E	●19E	●19E	●20E	●24E	●24E	●24E	●20E	●20E	●20E	●20E	●20E	●20E	K 3
3.4	●18C	●18C	●18E	●18E	●14E	●17E	●17E	●17E	●14E	●14E	●14E	●14E	●14E	●14E	K 4
4.1	●23E	●23E	●27G	●27G	●24F	●29F	●29F	●29F	●24F	●24F	●24F	●24F	●24F	●24F	S 1
4.2	●14C	●14C	●16E	●16E	●13D	●16D	●16D	●16D	●13D	●13D	●13D	●13D	●13D	●13D	S 2
4.3	●8A	●8A	●8C	●8C	●7B	●8B	●8B	●8B	●7B	●7B	●7B	●7B	●7B	●7B	S 3
5.1	●10G	●10G	●13I	●13I	●10G	●12G	●12G	●12G	●10G	●10G	●10G	●10G	●10G	●10G	S 1
5.2	●6C	●6C	●8G	●8G	●5E	●6E	●6E	●6E	●5E	●5E	●5E	●5E	●5E	●5E	S 2
5.3	●4A	●4A	●4C	●4C	●4A	●5A	●5A	●5A	●4A	●4A	●4A	●4A	●4A	●4A	S 3
6.1	●35E	●35E	●35G	●35G	●35G	●42G	●42G	●42G	●35G	●35G	●35G	●35G	●35G	●35G	N 3
6.2	●40E	●40E	●40G	●40G	●33I	●40I	●40I	●40I	●33I	●33I	●33I	●33I	●33I	●33I	N 4
6.3	●32E	●32E	●32G	●32G	●27H	●32H	●32H	●32H	●27H	●27H	●27H	●27H	●27H	●27H	N 3
6.4	●20E	●20E	●20G	●20G	●16G	●19G	●19G	●19G	●16G	●16G	●16G	●16G	●16G	●16G	N 4
7.1	●45E	●45E	●45G	●45G	●33J	●40J	●40J	●40J	●33J	●33J	●33J	●33J	●33J	●33J	N 1
7.2	●32E	●32E	●32G	●32G	●30I	●36I	●36I	●36I	●30I	●30I	●30I	●30I	●30I	●30I	N 1
7.3	●32E	●32E	●27G	●27G	●27H	●32H	●32H	●32H	●27H	●27H	●27H	●27H	●27H	●27H	N 1
7.4	●25E	●25E	●25G	●25G	●22H	●26H	●26H	●26H	●22H	●22H	●22H	●22H	●22H	●22H	N 2
8.1	●30I	●30I	●30I	●30I	●30J	●36J	●36J	●36J	●30J	●30J	●30J	●30J	●30J	●30J	O
8.2					●28H	●34H	●34H	●34H	●28H	●28H	●28H	●28H	●28H	●28H	O
8.3					●14F	●17F	●17F	●17F	●14F	●14F	●14F	●14F	●14F	●14F	O
9.1					●3B	●4B	●4B	●4B	●3B	●3B	●3B	●3B	●3B	●3B	H
10.1															O

								
	A088	A095	A087	A094	A089	A099	A099	
	Set	Set	Set	Set	Set	Set	DRILLBOY	
AMG	130	131	132	 133	134	135	135	ISO
1.1								P 1
1.2								P 1
1.3								P 2
1.4								P 3
1.5								P 4
1.6								H 1
1.7								H 3
1.8								H 4
2.1								M 1
2.2								M 3
2.3								M 2
2.4								S 2
3.1								K 1
3.2								K 2
3.3								K 3
3.4								K 4
4.1								S 1
4.2								S 2
4.3								S 3
5.1								S 1
5.2								S 2
5.3								S 3
6.1								N 3
6.2								N 4
6.3								N 3
6.4								N 4
7.1								N 1
7.2								N 1
7.3								N 1
7.4								N 2
8.1								O
8.2								O
8.3								O
9.1								H
10.1								O



A199
Set

A080
Set

A190
Set

A191
Set

A188
Set

A295
Set

A296
Set

AMG	136	137	 138	139	140	141	142	ISO
1.1								P 1
1.2								P 1
1.3								P 2
1.4								P 3
1.5								P 4
1.6								H 1
1.7								H 3
1.8								H 4
2.1								M 1
2.2								M 3
2.3								M 2
2.4								S 2
3.1								K 1
3.2								K 2
3.3								K 3
3.4								K 4
4.1								S 1
4.2								S 2
4.3								S 3
5.1								S 1
5.2								S 2
5.3								S 3
6.1								N 3
6.2								N 4
6.3								N 3
6.4								N 4
7.1								N 1
7.2								N 1
7.3								N 1
7.4								N 2
8.1								O
8.2								O
8.3								O
9.1								H
10.1								O

Fn	HM		HSS HM		HSS		HSS-E									
	Ø(D)	1mm	2mm	3mm	4mm	5mm	6mm	8mm	10mm	12mm	15mm	16mm	20mm	25mm	30mm	40mm
A	0.012	0.023	0.029	0.032	0.036	0.042	0.054	0.062	0.069	0.082	0.086	0.110	0.125	0.135	0.155	0.175
B	0.014	0.028	0.037	0.041	0.046	0.053	0.067	0.080	0.090	0.103	0.108	0.135	0.153	0.165	0.188	0.208
C	0.015	0.032	0.044	0.050	0.056	0.064	0.080	0.098	0.110	0.125	0.130	0.160	0.180	0.195	0.220	0.240
D	0.016	0.038	0.053	0.060	0.068	0.078	0.098	0.119	0.130	0.149	0.155	0.188	0.210	0.228	0.253	0.275
E	0.017	0.043	0.062	0.071	0.080	0.092	0.115	0.140	0.150	0.173	0.180	0.215	0.240	0.260	0.285	0.310
F	0.018	0.050	0.073	0.084	0.095	0.109	0.138	0.165	0.178	0.202	0.210	0.248	0.275	0.295	0.320	0.343
G	0.019	0.056	0.084	0.096	0.109	0.126	0.160	0.190	0.205	0.231	0.240	0.280	0.310	0.330	0.355	0.375
H	0.020	0.066	0.102	0.116	0.130	0.150	0.190	0.228	0.243	0.271	0.280	0.320	0.355	0.375	0.398	0.418
I	0.021	0.076	0.119	0.134	0.150	0.173	0.220	0.265	0.280	0.310	0.320	0.360	0.400	0.420	0.440	0.460
J	0.024	0.084	0.135	0.152	0.170	0.197	0.250	0.298	0.315	0.349	0.360	0.405	0.445	0.465	0.485	0.503
K	0.026	0.092	0.150	0.170	0.190	0.220	0.280	0.330	0.350	0.388	0.400	0.450	0.490	0.510	0.530	0.545
L	0.028	0.101	0.165	0.186	0.208	0.240	0.305	0.360	0.385	0.419	0.430	0.485	0.525	0.545	0.568	0.588
M	0.030	0.110	0.180	0.202	0.225	0.260	0.330	0.390	0.420	0.450	0.460	0.520	0.560	0.580	0.605	0.630
N	0.032	0.119	0.195	0.218	0.242	0.280	0.355	0.420	0.455	0.481	0.490	0.555	0.595	0.615	0.642	0.672
S	0.008	0.014	0.020	0.025	0.030	0.037	0.050	0.080	0.100	0.123	0.130	0.150				
T	0.015	0.028	0.040	0.050	0.060	0.070	0.090	0.110	0.130	0.160	0.170	0.190				
U	0.026	0.048	0.070	0.080	0.090	0.107	0.140	0.170	0.200	0.223	0.230	0.240				
V	0.038	0.069	0.100	0.115	0.130	0.153	0.200	0.250	0.280	0.310	0.320	0.340				
W	0.049	0.089	0.130	0.150	0.170	0.200	0.260	0.330	0.380	0.418	0.430	0.450				
X	0.056	0.103	0.150	0.180	0.210	0.250	0.330	0.420	0.480	0.533	0.550	0.580				
Y	0.068	0.124	0.180	0.220	0.260	0.317	0.430	0.550	0.700	0.700	0.700	0.740				
Z	0.094	0.172	0.250	0.325	0.400	0.533	0.800	1.000	1.100	1.175	1.200	1.200				

mm/N ± 25 %

$$n = \frac{V_c \times 1000}{\pi \times D}$$

$$V_f = n \times f \times n$$

Fn	HM						
Ø(D)	12mm	15mm	16mm	20mm	25mm	30mm	40mm
S	0.100	0.123	0.130	0.150	0.170	0.190	0.220
T	0.130	0.160	0.170	0.190	0.210	0.230	0.260
U	0.200	0.223	0.230	0.240	0.270	0.300	0.360
V	0.280	0.310	0.320	0.340	0.400	0.440	0.510
W	0.380	0.418	0.430	0.450	0.470	0.490	0.520

mm/N ± 25 %

R950 R960 R970		18
H853 H855 H858		21
H860 H861		24



H861	H860	R950 R960 R970	H853 H855 H858
------	------	----------------------	----------------------

R950	R960	R970	H853	H855	H858	H860	H861
15/32 - 42.00	15/32 - 30.50	15/32 - 42.00	15/32 - 42.00	15/32 - 30.50	15/32 - 42.00	N1 - N7	N1 - N6

R950	R960	R970	H853	H855	H858	H860	H861
R95015/32	R96015/32	R97015/32					
R95012.0	R96012.0	R97012.0					
R95012.1	R96012.1	R97012.1	H85312.0	H85512.0	H85812.0		
R95012.2	R96012.2	R97012.2	H85331/64	H85531/64			
R95031/64	R96031/64	R97031/64					
R95012.5	R96012.5	R97012.5					
R95012.6	R96012.6	R97012.6	H85312.5	H85512.5	H85812.5	H860N1	H860N1
R9501/2	R9601/2	R9701/2	H8531/2	H8551/2			
R95012.8	R96012.8	R97012.8					
R95012.9	R96012.9	R97012.9					
R95013.0	R96013.0	R97013.0					
R95033/64	R96033/64	R97033/64	H85313.0	H85513.0	H85813.0		
R95013.2	R96013.2	R97013.2	H85317/32	H85517/32			
R95017/32	R96017/32	R97017/32					
R95013.5	R96013.5	R97013.5					
R95013.6	R96013.6	R97013.6					
R95013.7	R96013.7	R97013.7					
R95013.8	R96013.8	R97013.8					
R95035/64	R96035/64	R97035/64	H85314.0	H85514.0	H85814.0		
R95014.0	R96014.0	R97014.0	H8539/16	H8559/16			
R95014.1	R96014.1	R97014.1					
R95014.2	R96014.2	R97014.2					
R9509/16	R9609/16	R9709/16					
R95014.5	R96014.5	R97014.5					
R95014.6	R96014.6	R97014.6				H860N1	H861N1
R95037/64	R96037/64	R97037/64					
R95014.7	R96014.7	R97014.7					
R95014.8	R96014.8	R97014.8					
R95015.0	R96015.0	R97015.0	H85315.0	H85515.0	H85815.0		
R95019/32	R96019/32	R97019/32	H85339/64	H85539/64			
R95015.1	R96015.1	R97015.1					
R95015.2	R96015.2	R97015.2					
R95039/64	R96039/64	R97039/64					
R95015.5	R96015.5	R97015.5					

R950	R960	R970	H853	H855	H858	H860	H861
R95015.6	R96015.6	R97015.6					
R95015.7	R96015.7	R97015.7					
R9505/8	R9605/8	R9705/8					
R95016.0	R96016.0	R97016.0					
R95016.1	R96016.1	R97016.1	H85316.0	H85516.0	H85816.0		
R95016.2	R96016.2	R97016.2	H85341/64	H85541/64			
R95041/64	R96041/64	R97041/64					
R95016.5	R96016.5	R97016.5					
R95016.6	R96016.6	R97016.6					
R95021/32	R96021/32	R97021/32					
R95016.7	R96016.7	R97016.7					
R95017.0	R96017.0	R97017.0					
R95043/64	R96043/64	R97043/64	H85317.0	H85517.0	H85817.0	H860N2	H861N2
R95017.1	R96017.1	R97017.1	H85311/16	H85511/16			
R95017.2	R96017.2	R97017.2					
R95011/16	R96011/16	R97011/16					
R95017.5	R96017.5	R97017.5					
R95017.6	R96017.6	R97017.6					
R95017.7	R96017.7	R97017.7					
R95045/64	R96045/64	R97045/64					
R95018.0	R96018.0	R97018.0	H85318.0	H85518.0	H85818.0		
R95018.1	R96018.1	R97018.1	H85323/32	H85523/32			
R95018.2	R96018.2	R97018.2					
R95023/32	R96023/32	R97023/32					
R95018.5	R96018.5	R97018.5					
R95018.6	R96018.6	R97018.6					
R95047/64	R96047/64	R97047/64					
R95018.7	R96018.7	R97018.7					
R95018.9	R96018.9	R97018.9					
R95019.0	R96019.0	R97019.0					
R9503/4	R9603/4	R9703/4	H85319.0	H85519.0	H85819.0		
R95019.1	R96019.1	R97019.1	H85349/64	H85549/64			
R95019.2	R96019.2	R97019.2					
R95019.25	R96019.25	R97019.25					
R95049/64	R96049/64	R97049/64					
R95019.5	R96019.5	R97019.5				H860N3	H861N3
R95019.6	R96019.6	R97019.6					
R95019.7	R96019.7	R97019.7					
R95025/32	R96025/32	R97025/32	H85320.0	H85520.0	H85820.0		
R95020.0	R96020.0	R97020.0	H85351/64	H85551/64			
R95051/64	R96051/64	R97051/64					
R95020.5	R96020.5	R97020.5					
R95013/16	R96013/16	R97013/16					
R95021.0	R96021.0	R97021.0					
R95053/64	R96053/64	R97053/64	H85321.0	H85521.0	H85821.0		
R95027/32	R96027/32	R97027/32	H85327/32	H85527/32			
R95021.5	R96021.5	R97021.5					
R95055/64	R96055/64	R97055/64					
R95022.0	R96022.0	R97022.0					
R9507/8	R9607/8	R9707/8	H85322.0	H85522.0	H85822.0		
R95022.5	R96022.5	R97022.5	H85357/64	H85557/64			
R95057/64	R96057/64	R97057/64					
R95022.7	R96022.7	R97022.7					
R95023.0	R96023.0	R97023.0					
R95029/32	R96029/32	R97029/32	H85323.0	H85523.0	H85823.0	H860N4	H861N3
R95059/64	R96059/64	R97059/64	H85359/64	H85559/64			
R95023.5	R96023.5	R97023.5					
R95015/16	R96015/16	R97015/16					
R95024.0	R96024.0	R97024.0					
R95061/64	R96061/64	R97061/64	H85324.0	H85524.0	H85824.0		
R95024.5	R96024.5	R97024.5	H85331/32	H85531/32			
R95031/32	R96031/32	R97031/32					

R950	R960	R970	H853	H855	H858	H860	H861
R95025.0	R96025.0	R97025.0					
R95063/64	R96063/64	R97063/64					
R9501	R9601	R9701	H85325.0	H85525.0	H85825.0		
R95025.5	R96025.5	R97025.5	H8531.1/64	H8551.1/64			
R95025.65	R96025.65	R97025.65					
R9501.1/64	R9601.1/64	R9701.1/64					
R95026.0	R96026.0	R97026.0					
R9501.1/32	R9601.1/32	R9701.1/32	H85326.0	H85526.0	H85826.0	H860N5	H861N4
R95026.5	R96026.5	R97026.5	H8531.3/64	H8551.3/64			
R9501.3/64	R9601.3/64	R9701.3/64					
R9501.1/16	R9601.1/16	R9701.1/16					
R95027.0	R96027.0	R97027.0					
R9501.5/64	R9601.5/64	R9701.5/64	H85327.0	H85527.0	H85827.0		
R95027.5	R96027.5	R97027.5	H8531.3/32	H8551.3/32			
R9501.3/32	R9601.3/32	R9701.3/32					
R95028.0	R96028.0	R97028.0					
R9501.7/64	R9601.7/64	R9701.7/64	H85328.0	H85528.0	H85828.0		
R95028.5	R96028.5	R97028.5	H8531.1/8	H8551.1/8			
R9501.1/8	R9601.1/8	R9701.1/8					
R9501.9/64	R9601.9/64	R9701.9/64					
R95029.0	R96029.0	R97029.0					
R9501.5/32	R9601.5/32	R9701.5/32	H85329.0	H85529.0	H85829.0		
R95029.5	R96029.5	R97029.5	H8531.11/64	H8551.11/64			
R9501.11/64	R9601.11/64	R9701.11/64					
R95030.0	R96030.0	R97030.0					
R9501.3/16	R9601.3/16	R9701.3/16	H85330.0	H85530.0	H85830.0	H860N6	H861N5
R95030.5	R96030.5	R97030.5	H8531.3/16	H8551.3/16			
R9501.7/32		R9701.7/32					
R95031.0		R97031.0					
R9501.1/4		R9701.1/4	H85332.0	H85532.0	H85832.0		
R95032.0		R97032.0					
R95032.5		R97032.5					
R9501.19/64		R9701.19/64					
R95033.0		R97033.0	H85333.5	H85533.5	H85833.5		
R95033.5		R97033.5					
R95034.0		R97034.0					
R9501.11/32		R9701.11/32					
R95034.5		R97034.5	H85335.0	H85535.0	H85835.0		
R9501.3/8		R9701.3/8					
R95035.0		R97035.0					
R95036.0		R97036.0					
R9501.27/64		R9701.27/64	H85336.5	H85536.5	H85836.5		
R95036.5		R97036.5					
R95037.0		R97037.0					
R9501.15/32		R9701.15/32					
R95037.5		R97037.5	H85338.0	H85538.0	H85838.0		
R95038.0		R97038.0				H860N7	H861N6
R9501.1/2		R9701.1/2					
R95038.5		R97038.5					
R9501.17/32		R9701.17/32	H85339.5	H85539.5	H85839.5		
R95039.0		R97039.0					
R95039.5		R97039.5					
R9501.9/16		R9701.9/16					
R95040.0		R97040.0	H85341.0	H85541.0	H85841.0		
R95041.0		R97041.0					
R9501.5/8		R9701.5/8					
R95042.0		R97042.0	H85342.5	H85542.5	H85842.5		

R950

- Testa Hydra per acciaio
- Hydra-Bohrkopf für Stahl
- Hydra wisselplaat voor staal
- Tête Hydra pour les aciers

Quattro (4) viti e un (1) cacciavite sono compresi con il corpo punta
 Lieferung Bohrkörper einschl. vier (4) Schrauben und ein (1) Schraubendreher
 Levering wisselplaatboor incl. vier (4) schroeven en een (1) schroevendraaier
 Quatre (4) vis et un (1) tournevis sont inclus avec le corps

R960

- Testa Hydra per acciaio inossidabile
- Hydra-Bohrkopf für rostfreien Stahl
- Hydra wisselplaat voor roestvast staal
- Tête Hydra pour les aciers inoxydables

Quattro (4) viti e un (1) cacciavite sono compresi con il corpo punta
 Lieferung Bohrkörper einschl. vier (4) Schrauben und ein (1) Schraubendreher
 Levering wisselplaatboor incl. vier (4) schroeven en een (1) schroevendraaier
 Quatre (4) vis et un (1) tournevis sont inclus avec le corps

R970

- Testa Hydra per ghisa
- Hydra-Bohrkopf für Gusseisen
- Hydra wisselplaat voor gietijzer
- Tête Hydra pour les fontes

Quattro (4) viti e un (1) cacciavite sono compresi con il corpo punta
 Lieferung Bohrkörper einschl. vier (4) Schrauben und ein (1) Schraubendreher
 Levering wisselplaatboor incl. vier (4) schroeven en een (1) schroevendraaier
 Quatre (4) vis et un (1) tournevis sont inclus avec le corps



R950	▪	1.3	1.4	1.5	1.6	3.3	3.4	
	•	1.1	1.2	2.4				
R960	▪	1.1	1.2	2.1	2.2	2.3	3.1	3.2
	•	2.4	3.3	3.4	4.1			
R970	▪	3.1	3.2	3.3	3.4			

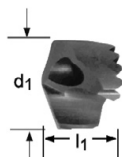

R950	R960	R970
15/32 - 42.00	15/32 - 30.50	15/32 - 42.00

d_1 \varnothing_{h_7} Inch	d_1 \varnothing_{h_7} mm	d_1 decimal Inch	l_1 mm	R950	R960	R970
15/32	11.91	0.4688	9.1	R95015/32	R96015/32	R97015/32
	12.00	0.4724	9.1	R95012.0	R96012.0	R97012.0
	12.10	0.4764	9.1	R95012.1	R96012.1	R97012.1
	12.20	0.4803	9.1	R95012.2	R96012.2	R97012.2
31/64	12.30	0.4844	9.1	R95031/64	R96031/64	R97031/64
	12.50	0.4921	9.4	R95012.5	R96012.5	R97012.5
	12.60	0.4961	9.4	R95012.6	R96012.6	R97012.6
1/2	12.70	0.5000	9.4	R9501/2	R9601/2	R9701/2
	12.80	0.5039	9.4	R95012.8	R96012.8	R97012.8
	12.90	0.5079	9.4	R95012.9	R96012.9	R97012.9
	13.00	0.5118	9.7	R95013.0	R96013.0	R97013.0
	13.10	0.5156	9.7	R95033/64	R96033/64	R97033/64
17/32	13.20	0.5197	9.7	R95013.2	R96013.2	R97013.2
	13.49	0.5313	9.7	R95017/32	R96017/32	R97017/32
	13.50	0.5315	10.3	R95013.5	R96013.5	R97013.5
	13.60	0.5354	10.3	R95013.6	R96013.6	R97013.6
	13.70	0.5394	10.3	R95013.7	R96013.7	R97013.7
	13.80	0.5433	10.3	R95013.8	R96013.8	R97013.8

d_1 $\varnothing h_7$ Inch	d_1 $\varnothing h_7$ mm	d_1 decimal Inch	l_1 mm	R950	R960	R970
35/64	13.89	0.5469	10.3	R95035/64	R96035/64	R97035/64
	14.00	0.5512	10.3	R95014.0	R96014.0	R97014.0
	14.10	0.5551	10.3	R95014.1	R96014.1	R97014.1
	14.20	0.5591	10.3	R95014.2	R96014.2	R97014.2
9/16	14.29	0.5625	10.3	R9509/16	R9609/16	R9709/16
	14.50	0.5709	10.3	R95014.5	R96014.5	R97014.5
	14.60	0.5748	11.0	R95014.6	R96014.6	R97014.6
37/64	14.68	0.5781	11.0	R95037/64	R96037/64	R97037/64
	14.70	0.5787	11.0	R95014.7	R96014.7	R97014.7
	14.80	0.5827	11.0	R95014.8	R96014.8	R97014.8
	15.00	0.5906	11.0	R95015.0	R96015.0	R97015.0
19/32	15.08	0.5938	11.0	R95019/32	R96019/32	R97019/32
	15.10	0.5945	11.0	R95015.1	R96015.1	R97015.1
	15.20	0.5984	11.0	R95015.2	R96015.2	R97015.2
39/64	15.48	0.6094	11.0	R95039/64	R96039/64	R97039/64
	15.50	0.6102	11.0	R95015.5	R96015.5	R97015.5
	15.60	0.6142	11.6	R95015.6	R96015.6	R97015.6
	15.70	0.6181	11.6	R95015.7	R96015.7	R97015.7
5/8	15.88	0.6250	11.6	R9505/8	R9605/8	R9705/8
	16.00	0.6299	11.6	R95016.0	R96016.0	R97016.0
	16.10	0.6339	11.6	R95016.1	R96016.1	R97016.1
	16.20	0.6378	11.6	R95016.2	R96016.2	R97016.2
41/64	16.27	0.6406	11.6	R95041/64	R96041/64	R97041/64
	16.50	0.6496	11.6	R95016.5	R96016.5	R97016.5
	16.60	0.6535	12.2	R95016.6	R96016.6	R97016.6
21/32	16.67	0.6563	12.2	R95021/32	R96021/32	R97021/32
	16.70	0.6575	12.2	R95016.7	R96016.7	R97016.7
	17.00	0.6693	12.2	R95017.0	R96017.0	R97017.0
43/64	17.07	0.6719	12.2	R95043/64	R96043/64	R97043/64
	17.10	0.6732	12.2	R95017.1	R96017.1	R97017.1
	17.20	0.6772	12.2	R95017.2	R96017.2	R97017.2
11/16	17.46	0.6875	12.2	R95011/16	R96011/16	R97011/16
	17.50	0.6890	12.2	R95017.5	R96017.5	R97017.5
	17.60	0.6929	12.9	R95017.6	R96017.6	R97017.6
	17.70	0.6969	12.9	R95017.7	R96017.7	R97017.7
45/64	17.86	0.7031	12.9	R95045/64	R96045/64	R97045/64
	18.00	0.7087	12.9	R95018.0	R96018.0	R97018.0
	18.10	0.7126	12.9	R95018.1	R96018.1	R97018.1
	18.20	0.7165	12.9	R95018.2	R96018.2	R97018.2
23/32	18.26	0.7188	12.9	R95023/32	R96023/32	R97023/32
	18.50	0.7283	12.9	R95018.5	R96018.5	R97018.5
	18.60	0.7323	13.5	R95018.6	R96018.6	R97018.6
47/64	18.65	0.7344	13.5	R95047/64	R96047/64	R97047/64
	18.70	0.7362	13.5	R95018.7	R96018.7	R97018.7
	18.90	0.7441	13.5	R95018.9	R96018.9	R97018.9
	19.00	0.7480	13.5	R95019.0	R96019.0	R97019.0
3/4	19.05	0.7500	13.5	R9503/4	R9603/4	R9703/4
	19.10	0.7520	13.5	R95019.1	R96019.1	R97019.1
	19.20	0.7559	13.5	R95019.2	R96019.2	R97019.2
	19.25	0.7579	13.5	R95019.25	R96019.25	R97019.25
49/64	19.45	0.7656	13.5	R95049/64	R96049/64	R97049/64
	19.50	0.7677	13.5	R95019.5	R96019.5	R97019.5
	19.60	0.7717	14.1	R95019.6	R96019.6	R97019.6
	19.70	0.7756	14.1	R95019.7	R96019.7	R97019.7
25/32	19.84	0.7813	14.1	R95025/32	R96025/32	R97025/32
	20.00	0.7874	14.1	R95020.0	R96020.0	R97020.0
51/64	20.24	0.7969	14.1	R95051/64	R96051/64	R97051/64
	20.50	0.8071	14.1	R95020.5	R96020.5	R97020.5
13/16	20.64	0.8125	14.8	R95013/16	R96013/16	R97013/16
	21.00	0.8268	14.8	R95021.0	R96021.0	R97021.0
53/64	21.03	0.8281	14.8	R95053/64	R96053/64	R97053/64
	21.43	0.8438	14.8	R95027/32	R96027/32	R97027/32
27/32	21.50	0.8465	14.8	R95021.5	R96021.5	R97021.5
	21.83	0.8594	15.0	R95055/64	R96055/64	R97055/64
55/64	22.00	0.8661	15.0	R95022.0	R96022.0	R97022.0
	22.22	0.8750	15.0	R9507/8	R9607/8	R9707/8
7/8	22.50	0.8858	15.0	R95022.5	R96022.5	R97022.5
	22.62	0.8906	15.0	R95057/64	R96057/64	R97057/64
57/64	22.70	0.8937	15.0	R95022.7	R96022.7	R97022.7
	23.00	0.9055	15.1	R95023.0	R96023.0	R97023.0

d ₁ Øh ₇ Inch	d ₁ Øh ₇ mm	d ₁ decimal Inch	l ₁ mm	R950	R960	R970
29/32	23.02	0.9063	15.1	R95029/32	R96029/32	R97029/32
59/64	23.42	0.9219	15.1	R95059/64	R96059/64	R97059/64
	23.50	0.9252	15.1	R95023.5	R96023.5	R97023.5
15/16	23.81	0.9375	15.4	R95015/16	R96015/16	R97015/16
	24.00	0.9449	15.4	R95024.0	R96024.0	R97024.0
61/64	24.21	0.9531	15.4	R95061/64	R96061/64	R97061/64
	24.50	0.9646	15.4	R95024.5	R96024.5	R97024.5
31/32	24.61	0.9688	15.4	R95031/32	R96031/32	R97031/32
	25.00	0.9844	15.8	R95025.0	R96025.0	R97025.0
63/64	25.00	0.9844	15.8	R95063/64	R96063/64	R97063/64
1"	25.40	1.0000	15.8	R9501	R9601	R9701
	25.50	1.0039	15.8	R95025.5	R96025.5	R97025.5
	25.65	1.0098	15.8	R95025.65	R96025.65	R97025.65
1.1/64	25.80	1.0156	15.8	R9501.1/64	R9601.1/64	R9701.1/64
	26.00	1.0236	16.4	R95026.0	R96026.0	R97026.0
1.1/32	26.19	1.0313	16.4	R9501.1/32	R9601.1/32	R9701.1/32
	26.50	1.0433	16.4	R95026.5	R96026.5	R97026.5
1.3/64	26.59	1.0469	16.4	R9501.3/64	R9601.3/64	R9701.3/64
1.1/16	26.99	1.0625	17.1	R9501.1/16	R9601.1/16	R9701.1/16
	27.00	1.0630	17.1	R95027.0	R96027.0	R97027.0
1.5/64	27.38	1.0781	17.1	R9501.5/64	R9601.5/64	R9701.5/64
	27.50	1.0827	17.1	R95027.5	R96027.5	R97027.5
1.3/32	27.78	1.0938	17.1	R9501.3/32	R9601.3/32	R9701.3/32
	28.00	1.1024	17.7	R95028.0	R96028.0	R97028.0
1.7/64	28.18	1.1094	17.7	R9501.7/64	R9601.7/64	R9701.7/64
	28.50	1.1220	17.7	R95028.5	R96028.5	R97028.5
1.1/8	28.58	1.1250	17.7	R9501.1/8	R9601.1/8	R9701.1/8
1.9/64	28.97	1.1406	18.3	R9501.9/64	R9601.9/64	R9701.9/64
	29.00	1.1417	18.3	R95029.0	R96029.0	R97029.0
1.5/32	29.37	1.1563	18.3	R9501.5/32	R9601.5/32	R9701.5/32
	29.50	1.1614	18.3	R95029.5	R96029.5	R97029.5
1.11/64	29.77	1.1719	18.3	R9501.11/64	R9601.11/64	R9701.11/64
	30.00	1.1811	19.0	R95030.0	R96030.0	R97030.0
1.3/16	30.16	1.1875	19.0	R9501.3/16	R9601.3/16	R9701.3/16
	30.50	1.2008	19.0	R95030.5	R96030.5	R97030.5
1.7/32	30.96	1.2188	21.0	R9501.7/32		R9701.7/32
	31.00	1.2205	21.0	R95031.0		R97031.0
1.1/4	31.75	1.2500	21.0	R9501.1/4		R9701.1/4
	32.00	1.2598	21.0	R95032.0		R97032.0
	32.50	1.2795	21.0	R95032.5		R97032.5
	32.94	1.2969	21.0	R9501.19/64		R9701.19/64
1.19/64	33.00	1.2992	21.0	R95033.0		R97033.0
	33.50	1.3189	21.0	R95033.5		R97033.5
	34.00	1.3386	23.0	R95034.0		R97034.0
	34.13	1.3438	23.0	R9501.11/32		R9701.11/32
1.11/32	34.50	1.3583	23.0	R95034.5		R97034.5
	34.93	1.3750	23.0	R9501.3/8		R9701.3/8
1.3/8	35.00	1.3780	23.0	R95035.0		R97035.0
	36.00	1.4173	23.0	R95036.0		R97036.0
	36.12	1.4219	23.0	R9501.27/64		R9701.27/64
1.27/64	36.50	1.4370	23.0	R95036.5		R97036.5
	37.00	1.4567	25.0	R95037.0		R97037.0
	37.31	1.4688	25.0	R9501.15/32		R9701.15/32
	37.50	1.4764	25.0	R95037.5		R97037.5
1.15/32	38.00	1.4961	25.0	R95038.0		R97038.0
	38.10	1.5000	25.0	R9501.1/2		R9701.1/2
	38.50	1.5157	25.0	R95038.5		R97038.5
1.17/32	38.89	1.5313	25.0	R9501.17/32		R9701.17/32
	39.00	1.5354	25.0	R95039.0		R97039.0
1.9/16	39.50	1.5551	25.0	R95039.5		R97039.5
	39.69	1.5625	27.0	R9501.9/16		R9701.9/16
	40.00	1.5748	27.0	R95040.0		R97040.0
	41.00	1.6142	27.0	R95041.0		R97041.0
1.5/8	41.28	1.6250	27.0	R9501.5/8		R9701.5/8
	42.00	1.6535	27.0	R95042.0		R97042.0

H853

- Corpo Hydra 3 x D
- Hydra Bohrkörper 3 x D
- Hydra wisselplaatboor 3 x D
- Corps Hydra 3 x D

Quattro (4) viti H860 e un (1) cacciavite H861 sono compresi con il corpo punta
 Lieferung Bohrkörper einschl. vier (4) Schrauben H860 und ein (1) Schraubendreher H861
 Levering wisselplaatboor incl. vier (4) schroeven en een (1) schroevendraaier
 Quatre (4) vis H860 et un (1) tournevis H861 sont inclus avec le corps

H855

- Corpo Hydra 5 x D
- Hydra Bohrkörper 5 x D
- Hydra wisselplaatboor 5 x D
- Corps Hydra 5 x D

Quattro (4) viti H860 e un (1) cacciavite H861 sono compresi con il corpo punta
 Lieferung Bohrkörper einschl. vier (4) Schrauben H860 und ein (1) Schraubendreher H861
 Levering wisselplaatboor incl. vier (4) schroeven en een (1) schroevendraaier
 Quatre (4) vis H860 et un (1) tournevis H861 sont inclus avec le corps

H858

- Corpo Hydra 8 x D
- Hydra Bohrkörper 8 x D
- Hydra wisselplaatboor 8 x D
- Corps Hydra 8 x D

Quattro (4) viti H860 e un (1) cacciavite H861 sono compresi con il corpo punta
 Lieferung Bohrkörper einschl. vier (4) Schrauben H860 und ein (1) Schraubendreher H861
 Levering wisselplaatboor incl. vier (4) schroeven en een (1) schroevendraaier
 Quatre (4) vis H860 et un (1) tournevis H861 sont inclus avec le corps

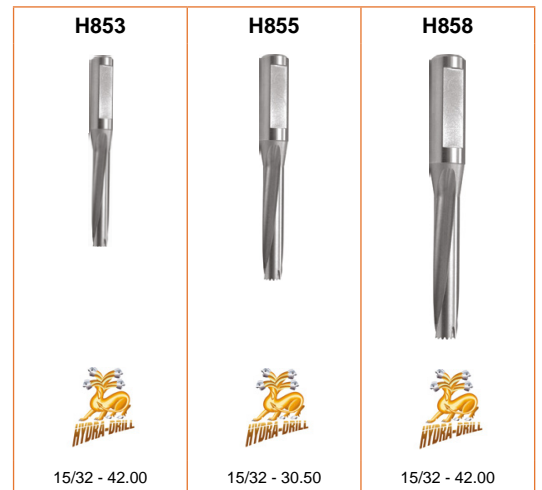
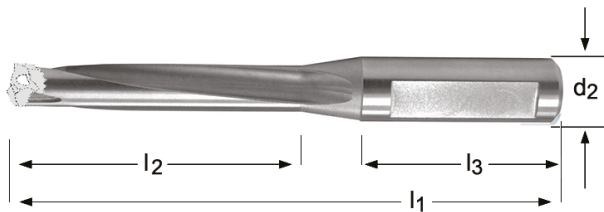
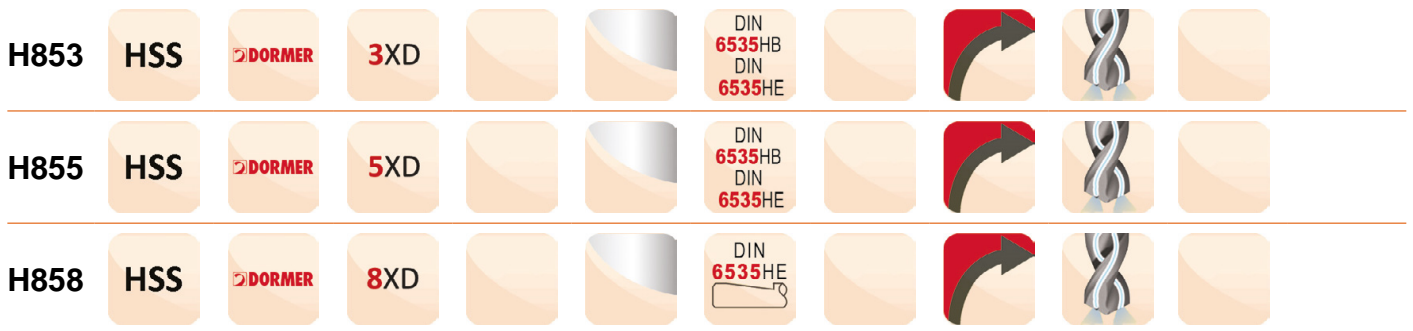

d_2 $\varnothing h_6$ Inch	d_2 $\varnothing h_6$ mm	l_2 mm	l_1 mm	l_3 mm	DIN 6535HB DIN 6535HE	H853	H855	H858
	16.00	44.0	105.0	48.0	DIN6535HE	H85312.0		
	16.00	69.0	130.0	48.0	DIN6535HE		H85512.0	
5/8	15.88	44.0	105.0	48.0	DIN6535HE	H85331/64		
5/8	15.88	69.0	130.0	48.0	DIN6535HE		H85531/64	
	16.00	44.0	105.0	48.0	DIN6535HE	H85312.5		
	16.00	69.0	130.0	48.0	DIN6535HE		H85512.5	
5/8	15.88	44.0	105.0	48.0	DIN6535HE	H8531/2		
5/8	15.88	69.0	130.0	48.0	DIN6535HE		H8551/2	
	16.00	47.0	110.0	48.0	DIN6535HE	H85313.0		
	16.00	74.0	140.0	48.0	DIN6535HE		H85513.0	
5/8	15.88	47.0	110.0	48.0	DIN6535HE	H85317/32		
5/8	15.88	74.0	140.0	48.0	DIN6535HE		H85517/32	
	16.00	124.5	191.5	48.0	DIN6535HE			H85814.0
	16.00	52.5	116.5	48.0	DIN6535HE	H85314.0		
	16.00	81.5	146.5	48.0	DIN6535HE		H85514.0	
3/4	19.05	52.5	116.5	48.0	DIN6535HE	H8539/16		
3/4	19.05	81.5	146.5	48.0	DIN6535HE		H8559/16	
	20.00	133.5	201.5	50.0	DIN6535HE			H85815.0
	20.00	55.5	126.5	50.0	DIN6535HE	H85315.0		
	20.00	86.5	156.5	50.0	DIN6535HE		H85515.0	
3/4	19.05	55.5	126.5	50.0	DIN6535HE	H85339/64		
3/4	19.05	86.5	156.5	50.0	DIN6535HE		H85539/64	

d_2 $\varnothing h_6$ Inch	d_2 $\varnothing h_6$ mm	l_2 mm	l_1 mm	l_3 mm	DIN 6535HB DIN 6535HE	H853	H855	H858
	20.00	141.5	211.5	50.0	DIN6535HE			H85816.0
	20.00	59.5	131.5	50.0	DIN6535HE	H85316.0		
	20.00	92.5	166.5	50.0	DIN6535HE		H85516.0	
3/4	19.05	59.5	131.5	50.0	DIN6535HE	H85341/64		
3/4	19.05	92.5	166.5	50.0	DIN6535HE		H85541/64	
	20.00	150.5	221.5	50.0	DIN6535HE			H85817.0
	20.00	62.5	136.5	50.0	DIN6535HE	H85317.0		
	20.00	97.5	171.5	50.0	DIN6535HE		H85517.0	
3/4	19.05	62.5	136.5	50.0	DIN6535HE	H85311/16		
3/4	19.05	97.5	171.5	50.0	DIN6535HE		H85511/16	
	20.00	158.5	226.5	50.0	DIN6535HE			H85818.0
	20.00	103.5	176.5	50.0	DIN6535HE		H85518.0	
	20.00	66.5	141.5	50.0	DIN6535HE	H85318.0		
3/4	19.05	103.5	176.5	50.0	DIN6535HE		H85523/32	
3/4	19.05	66.5	141.5	50.0	DIN6535HE	H85323/32		
	25.00	167.5	251.5	56.0	DIN6535HE			H85819.0
	25.00	108.5	191.5	56.0	DIN6535HE		H85519.0	
	25.00	69.5	156.5	56.0	DIN6535HE	H85319.0		
1"	25.40	108.5	191.5	56.0	DIN6535HE		H85549/64	
1"	25.40	69.5	156.5	56.0	DIN6535HE	H85349/64		
	25.00	175.5	264.5	56.0	DIN6535HE			H85820.0
	25.00	114.5	196.5	56.0	DIN6535HE		H85520.0	
	25.00	73.5	156.5	56.0	DIN6535HE	H85320.0		
1"	25.40	114.5	196.5	56.0	DIN6535HE		H85551/64	
1"	25.40	73.5	156.5	56.0	DIN6535HE	H85351/64		
	25.00	184.5	266.5	56.0	DIN6535HE			H85821.0
	25.00	119.5	196.5	56.0	DIN6535HE		H85521.0	
	25.00	76.5	156.5	56.0	DIN6535HE	H85321.0		
1"	25.40	119.5	196.5	56.0	DIN6535HE		H85527/32	
1"	25.40	76.5	156.5	56.0	DIN6535HE	H85327/32		
	25.00	192.1	271.1	56.0	DIN6535HE			H85822.0
	25.00	125.1	201.1	56.0	DIN6535HE		H85522.0	
	25.00	80.1	161.5	56.0	DIN6535HE	H85322.0		
1"	25.40	125.1	201.1	56.0	DIN6535HE		H85557/64	
1"	25.40	80.1	161.5	56.0	DIN6535HE	H85357/64		
	25.00	200.5	280.5	56.0	DIN6535HE			H85823.0
	25.00	129.5	210.5	56.0	DIN6535HE		H85523.0	
	25.00	82.5	160.5	56.0	DIN6535HE	H85323.0		
1"	25.40	129.5	210.5	56.0	DIN6535HE		H85559/64	
1"	25.40	82.5	160.5	56.0	DIN6535HE	H85359/64		
	32.00	208.2	295.2	60.0	DIN6535HE			H85824.0
	32.00	135.2	220.2	60.0	DIN6535HE		H85524.0	
	32.00	86.2	170.2	60.0	DIN6535HE	H85324.0		
1"	25.40	135.2	220.2	60.0	DIN6535HE		H85531/32	
1"	25.40	86.2	170.2	60.0	DIN6535HE	H85331/32		
	32.00	217.0	300.0	60.0	DIN6535HE			H85825.0
	32.00	140.0	225.0	60.0	DIN6535HE		H85525.0	
	32.00	88.0	170.0	60.0	DIN6535HE	H85325.0		
1.1/4	31.75	140.0	225.0	60.0	DIN6535HE		H8551.1/64	
1.1/4	31.75	88.0	170.0	60.0	DIN6535HE	H8531.1/64		
	32.00	225.0	310.0	60.0	DIN6535HE			H85826.0
	32.00	146.0	230.0	60.0	DIN6535HE		H85526.0	
	32.00	92.0	175.0	60.0	DIN6535HE	H85326.0		
1.1/4	31.75	146.0	230.0	60.0	DIN6535HE		H8551.3/64	
1.1/4	31.75	92.0	175.0	60.0	DIN6535HE	H8531.3/64		
	32.00	234.0	320.0	60.0	DIN6535HE			H85827.0
	32.00	151.0	235.0	60.0	DIN6535HE		H85527.0	
	32.00	94.0	175.0	60.0	DIN6535HE	H85327.0		
1.1/4	31.75	151.0	235.0	60.0	DIN6535HE		H8551.3/32	
1.1/4	31.75	94.0	175.0	60.0	DIN6535HE	H8531.3/32		
	32.00	242.0	325.0	60.0	DIN6535HE			H85828.0
	32.00	157.0	240.0	60.0	DIN6535HE		H85528.0	
	32.00	97.0	180.0	60.0	DIN6535HE	H85328.0		
1.1/4	31.75	157.0	240.0	60.0	DIN6535HE		H8551.1/8	
1.1/4	31.75	97.0	180.0	60.0	DIN6535HE	H8531.1/8		
	32.00	251.0	335.0	60.0	DIN6535HE			H85829.0
	32.00	100.0	185.0	60.0	DIN6535HE	H85329.0		
	32.00	162.0	245.0	60.0	DIN6535HE		H85529.0	
1.1/4	31.75	100.0	185.0	60.0	DIN6535HE	H8531.11/64		
1.1/4	31.75	162.0	245.0	60.0	DIN6535HE		H8551.11/64	
	32.00	259.0	345.0	60.0	DIN6535HE			H85830.0
	32.00	104.0	185.0	60.0	DIN6535HE	H85330.0		
	32.00	167.0	255.0	60.0	DIN6535HE		H85530.0	
1.1/4	31.75	104.0	185.0	60.0	DIN6535HE	H8531.3/16		
1.1/4	31.75	167.0	255.0	60.0	DIN6535HE		H8551.3/16	
	32.00	176.5	261.5	60.0	DIN6535HE		H85532.0	

d_2 $\varnothing h_6$ Inch	d_2 $\varnothing h_6$ mm	l_2 mm	l_1 mm	l_3 mm	DIN 6535HB DIN 6535HE	H853	H855	H858
	32.00	271.5	356.5	60.0	DIN6535HE			H85832.0
	32.00	111.5	196.5	60.0	DIN6535HE	H85332.0		
	40.00	186.5	271.5	60.0	DIN6535HB		H85533.5	
	40.00	286.5	371.5	60.0	DIN6535HB			H85833.5
	40.00	116.5	201.5	60.0	DIN6535HB	H85333.5		
	40.00	196.5	291.5	70.0	DIN6535HB		H85535.0	
	40.00	301.5	396.5	70.0	DIN6535HB			H85835.0
	40.00	121.5	216.5	70.0	DIN6535HB	H85335.0		
	40.00	201.5	296.5	70.0	DIN6535HB		H85536.5	
	40.00	311.5	406.5	70.0	DIN6535HB			H85836.5
	40.00	125.5	221.5	70.0	DIN6535HB	H85336.5		
	40.00	211.5	306.5	70.0	DIN6535HB		H85538.0	
	40.00	326.5	421.5	70.0	DIN6535HB			H85838.0
	40.00	131.5	226.5	70.0	DIN6535HB	H85338.0		
	40.00	221.5	316.5	70.0	DIN6535HB		H85539.5	
	40.00	336.5	431.5	70.0	DIN6535HB			H85839.5
	40.00	136.5	231.5	70.0	DIN6535HB	H85339.5		
	40.00	226.5	325.6	70.0	DIN6535HB		H85541.0	
	40.00	351.5	451.5	70.0	DIN6535HB			H85841.0
	40.00	146.5	246.5	70.0	DIN6535HB	H85341.0		
	40.00	236.5	336.5	70.0	DIN6535HB		H85542.5	
	40.00	361.5	461.5	70.0	DIN6535HB			H85842.5
	40.00	151.6	251.6	70.0	DIN6535HB	H85342.5		

H860

- Hydra viti
- Hydra Schrauben
- Hydra schroeven
- Hydra vis

Quattro (4) viti e un (1) cacciavite sono compresi con il corpo punta
 Lieferung Bohrkörper einschl. vier (4) Schrauben und ein (1) Schraubendreher
 Levering wisselplaatboor incl. vier (4) schroeven en een (1) schroevendraaier
 Quatre (4) vis et un (1) tournevis sont inclus avec le corps

H861

- Hydra cacciavite
- Hydra Schraubendreher
- Hydra schroevendraaier
- Hydra tournevis

Quattro (4) viti e un (1) cacciavite sono compresi con il corpo punta
 Lieferung Bohrkörper einschl. vier (4) Schrauben und ein (1) Schraubendreher
 Levering wisselplaatboor incl. vier (4) schroeven en een (1) schroevendraaier
 Quatre (4) vis et un (1) tournevis sont inclus avec le corps



H860	H861
H860N7	H861N6
H860N6	H861N5
H860N5	H861N4
H860N4	H861N3
H860N3	H861N2
H860N2	H861N1
H860N1	H861N1

R200

- Punta da centro - 60°
- Zentrierbohrer - 60°
- Centerboor - 60°
- Foret à centrer - 60°

R200 ■ 1.1 1.2 1.3 1.4 1.5 1.6 3.1 3.2 3.3 3.4 6.1 6.2 6.3 6.4 7.1 7.2 7.3 7.4

R200 **HM** **DIN 333A** **1XD** **118°**

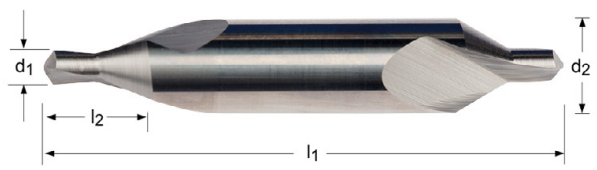

d_1 Ø mm	d_1 decimal Inch	l_2 max/min mm	l_1 mm	d_2 Ø mm	R200
1.00	0.0394	1.7 - 1.3	31	3.15	R2001.0X3.15
1.25	0.0492	2.0 - 1.6	31	3.15	R2001.25X3.15
1.60	0.0630	2.6 - 2.0	35	4.00	R2001.6X4.0
2.00	0.0787	3.1 - 2.5	40	5.00	R2002.0X5.0
2.50	0.0984	3.8 - 3.1	45	6.30	R2002.5X6.3
3.15	0.1240	4.6 - 3.9	50	8.00	R2003.15X8.0
4.00	0.1575	5.9 - 5.0	55	10.00	R2004.0X10.0
5.00	0.1969	7.2 - 6.3	63	12.50	R2005.0X12.5

R122

- Punta da centro - 120°
- NC-Anbohrer, extra kurz - 120°
- Extra korte NC-centerboor - 120°
- Foret extra court de pointage NC - 120°

Affilatura a 4 facce fino a 10,0 mm
4-Flächenanschliff bis 10 mm
Viervlakspunt tot 10,0 mm
Pointe à 4 facettes jusqu'au Ø 10,0 mm

R123

- Punta da centro - 90°
- NC-Anbohrer, extra kurz - 90°
- Extra korte NC-centerboor - 90°
- Foret extra court de pointage NC - 90°

Affilatura a 4 facce fino a 10,0 mm
4-Flächenanschliff bis 10 mm
Viervlakspunt tot 10,0 mm
Pointe à 4 facettes jusqu'au Ø 10,0 mm

R6011

- Punta da centro - 90°
- NC-Anbohrer - 90°
- NC-centerboor - 90°
- Foret de pointage nc - 90°

Rivestimento TiAlN
TiAlN beschichtet
TiAlN gecoat
Revêtu de TiAlN

R122; R123; R6011	1.1	1.2	1.3	1.4	1.5	1.6	1.7	1.8	2.1	2.2	3.1	3.2	3.3	3.4	4.1	4.2
	4.3	5.1	5.2	5.3	6.1	6.2	6.3	6.4	7.1	7.2	7.3	7.4	8.1	8.2		

R122	HM	DORMER	1XD	120°			N			
R123	HM	DORMER	1XD	90°			N			
R6011	HM	DORMER	1XD	90°	TiAlN	DIN 6535HA	N			

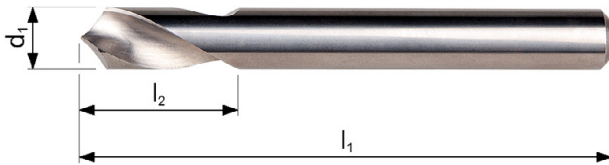

R122	R123	R6011
5.00 - 20.00	5.00 - 20.00	6.00 - 16.00

d ₁ Øh ₆ mm	d ₁ decimal Inch	l ₂ mm	l ₁ mm	R122	R123	R6011
5.00	0.1969	16	62	R1225.0	R1235.0	
6.00	0.2362	16	50			R60116.0
6.00	0.2362	17	66	R1226.0	R1236.0	
8.00	0.3150	22	79	R1228.0	R1238.0	
10.00	0.3937	25	70			R601110.0
10.00	0.3937	26	89	R12210.0	R12310.0	
12.00	0.4724	30	102	R12212.0	R12312.0	
16.00	0.6299	26	90			R601116.0
16.00	0.6299	34	115	R12216.0	R12316.0	
20.00	0.7874	40	131	R12220.0	R12320.0	

R7131

- Punta per smussi su preforni di maschiatura
- Stufenbohrer
- Kerngat-verzinkboor
- Foret étagé pour perçage avant taraudage

R7131	▪	1.1	1.2	1.3	1.4	1.5	2.1	2.2	2.3	3.1	3.2	3.3	3.4	6.1	6.2	6.3	6.4	7.1	7.2
		7.3	7.4																

R7131

HM

DORMER

3XD



N

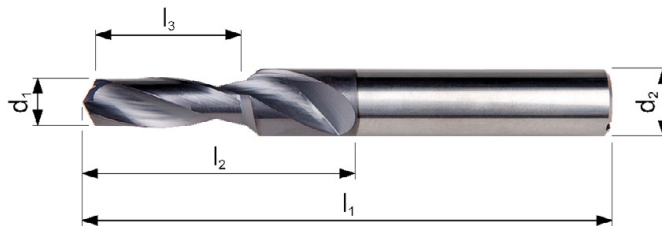

R7131



3.30 - 10.40

d_1 $\varnothing m_7$ mm	d_1 decimal Inch	l_3 mm	l_2 mm	l_1 mm	d_2 $\varnothing h_6$ mm	M	R7131
3.30	0.1299	11.4	20	66	6	M4	R71313.3
4.20	0.1654	13.6	24	66	6	M5	R71314.2
5.00	0.1969	16.5	28	79	8	M6	R71315.0
6.80	0.2677	21.0	34	89	10	M8	R71316.8
8.50	0.3346	25.5	47	102	12	M10	R71318.5
10.20	0.4016	30.0	55	107	14	M12	R713110.2
10.40	0.4094	30.0	55	107	14	M12	R713110.4

R120

- Punta serie extra-corta
- Spiralbohrer, kurz
- Extra korte spiraalboor
- Foret extra-court

R120	▪	4.1	5.1	6.1	7.1	8.1	8.2														
	•	1.1	1.2	1.3	1.4	1.5	1.6	1.7	1.8	3.1	3.2	3.3	3.4	4.2	4.3	5.2	5.3	6.2	6.3	6.4	7.2
		7.3	7.4																		

R120 **HM** **DIN 6539** **2.5XD** **120°**   **N**   

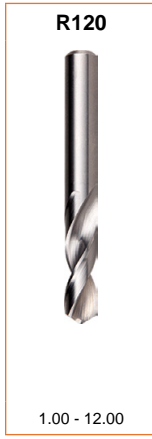
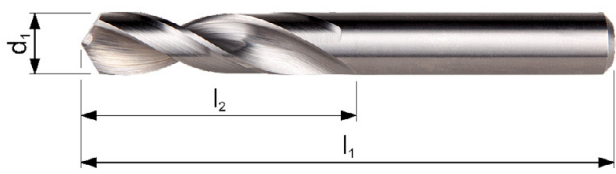

d_1 \varnothing_{h_7} mm	d_1 decimal Inch	l_2 mm	l_1 mm	R120
1.00	0.0394	6	26	R1201.0
1.10	0.0433	7	28	R1201.1
1.20	0.0472	8	30	R1201.2
1.30	0.0512	8	30	R1201.3
1.40	0.0551	9	32	R1201.4
1.50	0.0591	9	32	R1201.5
1.60	0.0630	10	34	R1201.6
1.70	0.0669	10	34	R1201.7
1.80	0.0709	11	36	R1201.8
1.90	0.0748	11	36	R1201.9
2.00	0.0787	12	38	R1202.0
2.10	0.0827	12	38	R1202.1
2.20	0.0866	13	40	R1202.2
2.30	0.0906	13	40	R1202.3
2.40	0.0945	14	43	R1202.4
2.50	0.0984	14	43	R1202.5
2.60	0.1024	14	43	R1202.6
2.70	0.1063	16	46	R1202.7
2.80	0.1102	16	46	R1202.8
2.90	0.1142	16	46	R1202.9
3.00	0.1181	16	46	R1203.0
3.10	0.1220	18	49	R1203.1
3.20	0.1260	18	49	R1203.2
3.30	0.1299	18	49	R1203.3
3.40	0.1339	20	52	R1203.4
3.50	0.1378	20	52	R1203.5
3.60	0.1417	20	52	R1203.6
3.70	0.1457	20	52	R1203.7
3.80	0.1496	22	55	R1203.8
3.90	0.1535	22	55	R1203.9
4.00	0.1575	22	55	R1204.0
4.10	0.1614	22	55	R1204.1
4.20	0.1654	22	55	R1204.2
4.30	0.1693	24	58	R1204.3
4.40	0.1732	24	58	R1204.4
4.50	0.1772	24	58	R1204.5
4.60	0.1811	24	58	R1204.6
4.70	0.1850	24	58	R1204.7

d₁ Øh₇ mm	d₁ decimal Inch	l₂ mm	l₁ mm	R120
4.80	0.1890	26	62	R1204.8
4.90	0.1929	26	62	R1204.9
5.00	0.1969	26	62	R1205.0
5.10	0.2008	26	62	R1205.1
5.20	0.2047	26	62	R1205.2
5.30	0.2087	26	62	R1205.3
5.40	0.2126	28	66	R1205.4
5.50	0.2165	28	66	R1205.5
5.60	0.2205	28	66	R1205.6
5.70	0.2244	28	66	R1205.7
5.80	0.2283	28	66	R1205.8
5.90	0.2323	28	66	R1205.9
6.00	0.2362	28	66	R1206.0
6.10	0.2402	31	70	R1206.1
6.20	0.2441	31	70	R1206.2
6.30	0.2480	31	70	R1206.3
6.40	0.2520	31	70	R1206.4
6.50	0.2559	31	70	R1206.5
6.60	0.2598	31	70	R1206.6
6.70	0.2638	31	70	R1206.7
6.80	0.2677	34	74	R1206.8
6.90	0.2717	34	74	R1206.9
7.00	0.2756	34	74	R1207.0
7.10	0.2795	34	74	R1207.1
7.20	0.2835	34	74	R1207.2
7.30	0.2874	34	74	R1207.3
7.40	0.2913	34	74	R1207.4
7.50	0.2953	34	74	R1207.5
7.60	0.2992	37	79	R1207.6
7.70	0.3031	37	79	R1207.7
7.80	0.3071	37	79	R1207.8
7.90	0.3110	37	79	R1207.9
8.00	0.3150	37	79	R1208.0
8.10	0.3189	37	79	R1208.1
8.20	0.3228	37	79	R1208.2
8.30	0.3268	37	79	R1208.3
8.40	0.3307	37	79	R1208.4
8.50	0.3346	37	79	R1208.5
8.60	0.3386	40	84	R1208.6
8.70	0.3425	40	84	R1208.7
8.80	0.3465	40	84	R1208.8
8.90	0.3504	40	84	R1208.9
9.00	0.3543	40	84	R1209.0
9.10	0.3583	40	84	R1209.1
9.20	0.3622	40	84	R1209.2
9.30	0.3661	40	84	R1209.3
9.40	0.3701	40	84	R1209.4
9.50	0.3740	40	84	R1209.5
9.60	0.3780	43	89	R1209.6
9.70	0.3819	43	89	R1209.7
9.80	0.3858	43	89	R1209.8
9.90	0.3898	43	89	R1209.9
10.00	0.3937	43	89	R12010.0
10.20	0.4016	43	89	R12010.2
10.50	0.4134	43	89	R12010.5
11.00	0.4331	47	95	R12011.0
11.50	0.4528	47	95	R12011.5
12.00	0.4724	51	102	R12012.0

R100

- Punta serie corta
- Spiralbohrer
- Spiraalboor
- Foret court

R100 ■ 6.2 6.3 8.1 8.2
 • 1.1 1.2 1.3 1.4 1.5 1.6 1.7 1.8 3.1 3.2 3.3 3.4 7.1 7.2 7.3 7.4

R100 HM DIN 338 4XD 120° N

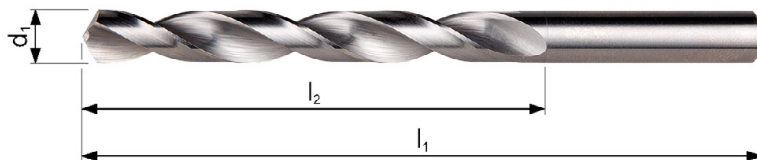

d_1 \varnothing_{h_7} mm	d_1 decimal inch	l_2 mm	l_1 mm	R100
1.00	0.0394	12	34	R1001.0
1.10	0.0433	14	36	R1001.1
1.20	0.0472	16	38	R1001.2
1.30	0.0512	16	38	R1001.3
1.40	0.0551	18	40	R1001.4
1.50	0.0591	18	40	R1001.5
1.60	0.0630	20	43	R1001.6
1.70	0.0669	20	43	R1001.7
1.80	0.0709	22	46	R1001.8
1.90	0.0748	22	46	R1001.9
2.00	0.0787	24	49	R1002.0
2.10	0.0827	24	49	R1002.1
2.20	0.0866	27	53	R1002.2
2.30	0.0906	27	53	R1002.3
2.40	0.0945	30	57	R1002.4
2.50	0.0984	30	57	R1002.5
2.60	0.1024	30	57	R1002.6
2.70	0.1063	33	61	R1002.7
2.80	0.1102	33	61	R1002.8
2.90	0.1142	33	61	R1002.9
3.00	0.1181	33	61	R1003.0
3.10	0.1220	36	65	R1003.1
3.20	0.1260	36	65	R1003.2
3.30	0.1299	36	65	R1003.3
3.40	0.1339	39	70	R1003.4
3.50	0.1378	39	70	R1003.5
3.60	0.1417	39	70	R1003.6
3.70	0.1457	39	70	R1003.7
3.80	0.1496	43	75	R1003.8
3.90	0.1535	43	75	R1003.9
4.00	0.1575	43	75	R1004.0
4.10	0.1614	43	75	R1004.1
4.20	0.1654	43	75	R1004.2
4.30	0.1693	47	80	R1004.3
4.40	0.1732	47	80	R1004.4
4.50	0.1772	47	80	R1004.5
4.60	0.1811	47	80	R1004.6
4.70	0.1850	47	80	R1004.7

d₁ Øh₇ mm	d₁ decimal Inch	l₂ mm	l₁ mm	R100
4.80	0.1890	52	86	R1004.8
4.90	0.1929	52	86	R1004.9
5.00	0.1969	52	86	R1005.0
5.10	0.2008	52	86	R1005.1
5.20	0.2047	52	86	R1005.2
5.30	0.2087	52	86	R1005.3
5.40	0.2126	57	93	R1005.4
5.50	0.2165	57	93	R1005.5
5.60	0.2205	57	93	R1005.6
5.70	0.2244	57	93	R1005.7
5.80	0.2283	57	93	R1005.8
5.90	0.2323	57	93	R1005.9
6.00	0.2362	57	93	R1006.0
6.10	0.2402	63	101	R1006.1
6.20	0.2441	63	101	R1006.2
6.30	0.2480	63	101	R1006.3
6.40	0.2520	63	101	R1006.4
6.50	0.2559	63	101	R1006.5
6.60	0.2598	63	101	R1006.6
6.70	0.2638	63	101	R1006.7
6.80	0.2677	69	109	R1006.8
6.90	0.2717	69	109	R1006.9
7.00	0.2756	69	109	R1007.0
7.10	0.2795	69	109	R1007.1
7.20	0.2835	69	109	R1007.2
7.30	0.2874	69	109	R1007.3
7.40	0.2913	69	109	R1007.4
7.50	0.2953	69	109	R1007.5
7.60	0.2992	75	117	R1007.6
7.70	0.3031	75	117	R1007.7
7.80	0.3071	75	117	R1007.8
7.90	0.3110	75	117	R1007.9
8.00	0.3150	75	117	R1008.0
8.10	0.3189	75	117	R1008.1
8.20	0.3228	75	117	R1008.2
8.30	0.3268	75	117	R1008.3
8.40	0.3307	75	117	R1008.4
8.50	0.3346	75	117	R1008.5
8.60	0.3386	81	125	R1008.6
8.70	0.3425	81	125	R1008.7
8.80	0.3465	81	125	R1008.8
8.90	0.3504	81	125	R1008.9
9.00	0.3543	81	125	R1009.0
9.10	0.3583	81	125	R1009.1
9.20	0.3622	81	125	R1009.2
9.30	0.3661	81	125	R1009.3
9.40	0.3701	81	125	R1009.4
9.50	0.3740	81	125	R1009.5
9.60	0.3780	87	133	R1009.6
9.70	0.3819	87	133	R1009.7
9.80	0.3858	87	133	R1009.8
9.90	0.3898	87	133	R1009.9
10.00	0.3937	87	133	R10010.0
10.20	0.4016	87	133	R10010.2
10.50	0.4134	87	133	R10010.5
11.00	0.4331	94	142	R10011.0
11.50	0.4528	94	142	R10011.5
12.00	0.4724	101	151	R10012.0
13.00	0.5118	101	151	R10013.0
14.00	0.5512	108	160	R10014.0

R520

- Punta CDX serie extra corta
- CDX Spiralbohrer, kurz
- CDX Spiraalboor, extra kort
- Foret CDX extra-court

R520	▪	1.1	1.2	1.3	1.4	1.5	1.6	3.1	3.2	3.3	3.4	5.1	7.1	7.2	7.3	7.4	8.1	8.2
	•	1.7	1.8	2.1	4.1	4.2	4.3											

R520 **HM** **DIN 6539** **2.5XD** **130°** **TiN** **N**

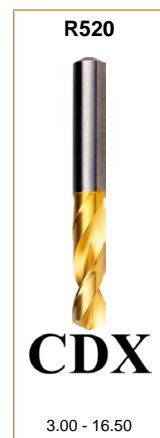
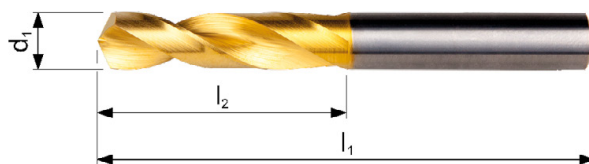

d_1 \varnothing_{h_7} Inch	d_1 \varnothing_{h_7} mm	d_1 decimal Inch	l_2 mm	l_1 mm	R520
1/8	3.00	0.1181	16	46	R5203.0
	3.10	0.1220	18	49	R5203.1
	3.18	0.1252	18	49	R5201/8
	3.20	0.1260	18	49	R5203.2
	3.30	0.1299	18	49	R5203.3
	3.40	0.1339	20	52	R5203.4
	3.50	0.1378	20	52	R5203.5
	3.60	0.1417	20	52	R5203.6
	3.70	0.1457	20	52	R5203.7
	3.80	0.1496	22	55	R5203.8
	3.90	0.1535	22	55	R5203.9
	4.00	0.1575	22	55	R5204.0
	4.10	0.1614	22	55	R5204.1
	4.20	0.1654	22	55	R5204.2
	4.30	0.1693	24	58	R5204.3
	4.40	0.1732	24	58	R5204.4
	4.50	0.1772	24	58	R5204.5
	4.60	0.1811	24	58	R5204.6
4.70	0.1850	24	58	R5204.7	
4.80	0.1890	26	62	R5204.8	
4.90	0.1929	26	62	R5204.9	
5.00	0.1969	26	62	R5205.0	
5.10	0.2008	26	62	R5205.1	
5.20	0.2047	26	62	R5205.2	
5.30	0.2087	26	62	R5205.3	
5.40	0.2126	28	66	R5205.4	
5.50	0.2165	28	66	R5205.5	
5.60	0.2205	28	66	R5205.6	
5.70	0.2244	28	66	R5205.7	
5.80	0.2283	28	66	R5205.8	
5.90	0.2323	28	66	R5205.9	
6.00	0.2362	28	66	R5206.0	
6.10	0.2402	31	70	R5206.1	
6.20	0.2441	31	70	R5206.2	
6.30	0.2480	31	70	R5206.3	
1/4	6.35	0.2500	31	70	R5201/4
	6.40	0.2520	31	70	R5206.4
	6.50	0.2559	31	70	R5206.5

d₁ Øh₇ Inch	d₁ Øh₇ mm	d₁ decimal Inch	l₂ mm	l₁ mm	R520
	6.60	0.2598	31	70	R5206.6
	6.70	0.2638	31	70	R5206.7
	6.80	0.2677	34	74	R5206.8
	6.90	0.2717	34	74	R5206.9
	7.00	0.2756	34	74	R5207.0
	7.10	0.2795	34	74	R5207.1
	7.20	0.2835	34	74	R5207.2
	7.30	0.2874	34	74	R5207.3
	7.40	0.2913	34	74	R5207.4
	7.50	0.2953	34	74	R5207.5
	7.60	0.2992	37	79	R5207.6
	7.70	0.3031	37	79	R5207.7
	7.80	0.3071	37	79	R5207.8
	7.90	0.3110	37	79	R5207.9
5/16	7.94	0.3126	37	79	R5205/16
	8.00	0.3150	37	79	R5208.0
	8.10	0.3189	37	79	R5208.1
	8.20	0.3228	37	79	R5208.2
	8.30	0.3268	37	79	R5208.3
	8.40	0.3307	37	79	R5208.4
	8.50	0.3346	37	79	R5208.5
	8.60	0.3386	40	84	R5208.6
	8.70	0.3425	40	84	R5208.7
	8.80	0.3465	40	84	R5208.8
	8.90	0.3504	40	84	R5208.9
	9.00	0.3543	40	84	R5209.0
	9.10	0.3583	40	84	R5209.1
	9.20	0.3622	40	84	R5209.2
	9.30	0.3661	40	84	R5209.3
	9.40	0.3701	40	84	R5209.4
	9.50	0.3740	40	84	R5209.5
3/8	9.52	0.3748	43	89	R5203/8
	9.60	0.3780	43	89	R5209.6
	9.70	0.3819	43	89	R5209.7
	9.80	0.3858	43	89	R5209.8
	9.90	0.3898	43	89	R5209.9
	10.00	0.3937	43	89	R52010.0
	10.10	0.3976	43	89	R52010.1
	10.20	0.4016	43	89	R52010.2
	10.30	0.4055	43	89	R52010.3
	10.40	0.4094	43	89	R52010.4
	10.50	0.4134	43	89	R52010.5
	11.00	0.4331	47	95	R52011.0
7/16	11.11	0.4374	47	95	R5207/16
	11.20	0.4409	47	95	R52011.2
	11.50	0.4528	47	95	R52011.5
	12.00	0.4724	51	102	R52012.0
	12.50	0.4921	51	102	R52012.5
1/2	12.70	0.5000	51	102	R5201/2
	13.00	0.5118	51	102	R52013.0
	13.50	0.5315	54	107	R52013.5
	14.00	0.5512	54	107	R52014.0
	14.20	0.5591	56	111	R52014.2
	14.25	0.5610	56	111	R52014.25
	14.50	0.5709	56	111	R52014.5
	15.00	0.5906	56	111	R52015.0
	15.10	0.5945	58	115	R52015.1
5/8	15.88	0.6252	58	115	R5205/8
	16.00	0.6299	58	115	R52016.0
	16.50	0.6496	60	119	R52016.5

R510

- Punta CDX serie corta
- CDX Spiralbohrer
- CDX Spiraalboor
- Foret CDX court

R510	▪	1.1	1.2	1.3	1.4	1.5	1.6	3.1	3.2	3.3	3.4	7.1	7.2	7.3	7.4	8.1	8.2
	•	1.7	1.8	2.1	4.1	5.1											

R510

HM

DIN
338

4XD



N

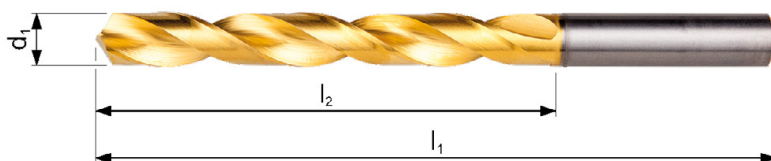

R510



CDX

3.00 - 14.25

d_1 Ø _{h7} Inch	d_1 Ø _{h7} mm	d_1 decimal Inch	l_2 mm	l_1 mm	R510
1/8	3.00	0.1181	33	61	R5103.0
	3.18	0.1252	36	65	R5101/8
	3.20	0.1260	36	65	R5103.2
	3.30	0.1299	36	65	R5103.3
	3.40	0.1339	39	70	R5103.4
	3.50	0.1378	39	70	R5103.5
	3.70	0.1457	39	70	R5103.7
	3.90	0.1535	43	75	R5103.9
	4.00	0.1575	43	75	R5104.0
	4.10	0.1614	43	75	R5104.1
	4.20	0.1654	43	75	R5104.2
	4.30	0.1693	47	80	R5104.3
	4.50	0.1772	47	80	R5104.5
	4.60	0.1811	47	80	R5104.6
3/16	4.70	0.1850	47	80	R5104.7
	4.76	0.1874	52	86	R5103/16
	4.90	0.1929	52	86	R5104.9
	5.00	0.1969	52	86	R5105.0
	5.10	0.2008	52	86	R5105.1
	5.50	0.2165	57	93	R5105.5
	5.60	0.2205	57	93	R5105.6
	5.70	0.2244	57	93	R5105.7
	6.00	0.2362	57	93	R5106.0
	1/4	6.35	0.2500	63	101
6.50		0.2559	63	101	R5106.5
6.60		0.2598	63	101	R5106.6
6.80		0.2677	69	109	R5106.8
6.90		0.2717	69	109	R5106.9
7.00		0.2756	69	109	R5107.0
7.30		0.2874	69	109	R5107.3
7.40		0.2913	69	109	R5107.4
7.50		0.2953	69	109	R5107.5
7.80		0.3071	75	117	R5107.8
5/16		7.90	0.3110	75	117
	7.94	0.3126	75	117	R5105/16
	8.00	0.3150	75	117	R5108.0

d₁ Øh₇ Inch	d₁ Øh₇ mm	d₁ decimal Inch	l₂ mm	l₁ mm	R510
	8.50	0.3346	75	117	R5108.5
	8.70	0.3425	81	125	R5108.7
	8.80	0.3465	81	125	R5108.8
	9.00	0.3543	81	125	R5109.0
	9.20	0.3622	81	125	R5109.2
	9.30	0.3661	81	125	R5109.3
	9.40	0.3701	81	125	R5109.4
	9.50	0.3740	81	125	R5109.5
3/8	9.52	0.3748	87	133	R5103/8
	9.90	0.3898	87	133	R5109.9
	10.00	0.3937	87	133	R51010.0
	10.20	0.4016	87	133	R51010.2
	10.30	0.4055	87	133	R51010.3
	10.40	0.4094	87	133	R51010.4
	10.50	0.4134	87	133	R51010.5
	10.80	0.4252	94	142	R51010.8
	11.00	0.4331	94	142	R51011.0
7/16	11.11	0.4374	94	142	R5107/16
	11.20	0.4409	94	142	R51011.2
	11.50	0.4528	94	142	R51011.5
	12.00	0.4724	101	151	R51012.0
1/2	12.70	0.5000	101	151	R5101/2
	13.00	0.5118	101	151	R51013.0
	14.00	0.5512	108	160	R51014.0
	14.25	0.5610	114	169	R51014.25

R458

- Punta Force-X 3XD
- Force-X Spiralbohrer, kurz 3XD
- Force-X Spiraalboor 3XD
- Foret Force-X 3XD

R457

- Punta Force-X con fori di lubrificazione 3XD
- Force-X Spiralbohrer - Kühlkanal 3XD
- Force-X Spiraalboor met koelkanalen 3XD
- Foret Force-X - à trous d'huile 3XD

R458	▪	1.1	1.2	1.3	1.4	1.5	1.6	1.7	1.8	2.1	2.2	2.3	3.1	3.2	3.3	3.4	6.1	6.2	6.3	7.1	7.2
		7.3	7.4																		
	•	2.4	4.1	4.2	4.3	6.4															
R457	▪	1.1	1.2	1.3	1.4	1.5	1.6	1.7	1.8	2.1	2.2	2.3	3.1	3.2	3.3	3.4	4.1	4.2	4.3	6.1	6.2
		6.3	6.4	7.1	7.2	7.3	7.4														

R458	HM	DIN 6537 K	3XD	140°	TiAlN	DIN 6535HA	CTW			
R457	HM	DIN 6537 K	3XD	140°	TiAlN	DIN 6535HA	CTW			

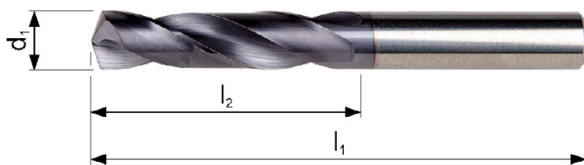

d_1 Ø "/Nr.	d_1 Ø _{m7} mm	d_1 decimal Inch	l_2 mm	l_1 mm	l_3 mm	d_2 Ø _{h6} mm	R458	R457
	3.00	0.1181	20	62	36	6	R4583.0	R4573.0
	3.10	0.1220	20	62	36	6	R4583.1	R4573.1
1/8	3.18	0.1252	20	62	36	6	R4581/8	R4571/8
	3.20	0.1260	20	62	36	6	R4583.2	R4573.2
30	3.26	0.1283	20	62	36	6	R458N30	R457N30
	3.30	0.1299	20	62	36	6	R4583.3	R4573.3
	3.40	0.1339	20	62	36	6	R4583.4	R4573.4
29	3.45	0.1358	20	62	36	6	R458N29	R457N29
	3.50	0.1378	20	62	36	6	R4583.5	R4573.5
28	3.57	0.1406	20	62	36	6	R458N28	R457N28
9/64	3.57	0.1406	20	62	36	6	R4589/64	R4579/64
	3.60	0.1417	20	62	36	6	R4583.6	R4573.6
27	3.66	0.1441	20	62	36	6	R458N27	R457N27
	3.70	0.1457	20	62	36	6	R4583.7	R4573.7
	3.73	0.1469	24	66	36	6	R4583.73	
26	3.73	0.1469	24	66	36	6	R458N26	R457N26
	3.80	0.1496	24	66	36	6	R4583.8	R4573.8
25	3.80	0.1496	24	66	36	6	R458N25	R457N25
24	3.86	0.1520	24	66	36	6	R458N24	R457N24
	3.90	0.1535	24	66	36	6	R4583.9	R4573.9
23	3.91	0.1539	24	66	36	6	R458N23	R457N23
5/32	3.97	0.1563	24	66	36	6	R4585/32	R4575/32
22	3.99	0.1571	24	66	36	6	R458N22	R457N22
	4.00	0.1575	24	66	36	6	R4584.0	R4574.0

d_1 Ø "/Nr.	d_1 Øm ₇ mm	d_1 decimal Inch	l_2 mm	l_1 mm	l_3 mm	d_2 Øh ₆ mm	R458	R457
21	4.04	0.1591	24	66	36	6	R458N21	R457N21
	4.05	0.1594	24	66	36	6		R4574.05
20	4.09	0.1610	24	66	36	6	R458N20	R457N20
	4.10	0.1614	24	66	36	6	R4584.1	R4574.1
	4.20	0.1654	24	66	36	6	R4584.2	R4574.2
19	4.22	0.1661	24	66	36	6	R458N19	R457N19
	4.30	0.1693	24	66	36	6	R4584.3	R4574.3
18	4.31	0.1697	24	66	36	6	R458N18	R457N18
11/64	4.37	0.1720	24	66	36	6	R45811/64	R45711/64
17	4.39	0.1728	24	66	36	6	R458N17	R457N17
	4.40	0.1732	24	66	36	6	R4584.4	R4574.4
16	4.50	0.1772	24	66	36	6	R458N16	R457N16
	4.50	0.1772	24	66	36	6	R4584.5	R4574.5
15	4.57	0.1799	24	66	36	6	R458N15	R457N15
	4.60	0.1811	24	66	36	6	R4584.6	R4574.6
14	4.62	0.1819	24	66	36	6	R458N14	R457N14
	4.70	0.1850	24	66	36	6	R4584.7	R4574.7
13	4.70	0.1850	24	66	36	6	R458N13	R457N13
3/16	4.76	0.1874	28	66	36	6	R4583/16	R4573/16
	4.80	0.1890	28	66	36	6	R4584.8	R4574.8
12	4.80	0.1890	28	66	36	6	R458N12	R457N12
11	4.85	0.1909	28	66	36	6	R458N11	R457N11
	4.90	0.1929	28	66	36	6	R4584.9	R4574.9
10	4.92	0.1937	28	66	36	6	R458N10	R457N10
9	4.98	0.1961	28	66	36	6	R458N9	R457N9
	5.00	0.1969	28	66	36	6	R4585.0	R4575.0
	5.05	0.1988	28	66	36	6		R4575.05
8	5.06	0.1992	28	66	36	6	R458N8	R457N8
	5.10	0.2008	28	66	36	6	R4585.1	R4575.1
7	5.11	0.2012	28	66	36	6	R458N7	R457N7
13/64	5.16	0.2031	28	66	36	6	R45813/64	R45713/64
6	5.18	0.2039	28	66	36	6	R458N6	R457N6
	5.20	0.2047	28	66	36	6	R4585.2	R4575.2
5	5.22	0.2055	28	66	36	6	R458N5	R457N5
	5.30	0.2087	28	66	36	6	R4585.3	R4575.3
4	5.31	0.2091	28	66	36	6	R458N4	R457N4
	5.40	0.2126	28	66	36	6	R4585.4	R4575.4
3	5.41	0.2130	28	66	36	6	R458N3	R457N3
	5.50	0.2165	28	66	36	6	R4585.5	R4575.5
7/32	5.56	0.2189	28	66	36	6	R4587/32	R4577/32
	5.60	0.2205	28	66	36	6	R4585.6	R4575.6
2	5.61	0.2209	28	66	36	6	R458N2	R457N2
	5.70	0.2244	28	66	36	6	R4585.7	R4575.7
1	5.79	0.2280	28	66	36	6	R458N1	R457N1
	5.80	0.2283	28	66	36	6	R4585.8	R4575.8
	5.90	0.2323	28	66	36	6	R4585.9	R4575.9
A	5.94	0.2339	28	66	36	6	R458A	R457A
15/64	5.95	0.2343	28	66	36	6	R45815/64	R45715/64
	6.00	0.2362	28	66	36	6	R4586.0	R4576.0
B	6.03	0.2374	34	79	36	8	R458B	R457B
	6.05	0.2382	34	79	36	8		R4576.05
	6.10	0.2402	34	79	36	8	R4586.1	R4576.1
C	6.15	0.2421	34	79	36	8	R458C	R457C
	6.20	0.2441	34	79	36	8	R4586.2	R4576.2
D	6.25	0.2461	34	79	36	8	R458D	R457D
	6.30	0.2480	34	79	36	8	R4586.3	R4576.3
1/4	6.35	0.2500	34	79	36	8	R4581/4	R4571/4
E	6.35	0.2500	34	79	36	8	R458E	R457E
	6.40	0.2520	34	79	36	8	R4586.4	R4576.4
	6.50	0.2559	34	79	36	8	R4586.5	R4576.5
F	6.53	0.2571	34	79	36	8	R458F	R457F
	6.60	0.2598	34	79	36	8	R4586.6	R4576.6
G	6.63	0.2610	34	79	36	8	R458G	R457G
	6.70	0.2638	34	79	36	8	R4586.7	R4576.7
17/64	6.75	0.2657	34	79	36	8	R45817/64	R45717/64
H	6.76	0.2661	34	79	36	8	R458H	R457H
	6.80	0.2677	34	79	36	8	R4586.8	R4576.8
	6.90	0.2717	34	79	36	8	R4586.9	R4576.9
I	6.91	0.2720	34	79	36	8	R458I	R457I
	7.00	0.2756	34	79	36	8	R4587.0	R4577.0

d ₁ Ø "/Nr.	d ₁ Øm ₇ mm	d ₁ decimal Inch	l ₂ mm	l ₁ mm	l ₃ mm	d ₂ Øh ₅ mm	R458	R457
J	7.04	0.2772	41	79	36	8	R458J	R457J
	7.10	0.2795	41	79	36	8	R4587.1	R4577.1
K	7.14	0.2811	41	79	36	8	R458K	R457K
9/32	7.14	0.2811	41	79	36	8	R4589/32	R4579/32
	7.20	0.2835	41	79	36	8	R4587.2	R4577.2
	7.30	0.2874	41	79	36	8	R4587.3	R4577.3
L	7.37	0.2902	41	79	36	8	R458L	R457L
	7.40	0.2913	41	79	36	8	R4587.4	R4577.4
M	7.49	0.2949	41	79	36	8	R458M	R457M
	7.50	0.2953	41	79	36	8	R4587.5	R4577.5
19/64	7.54	0.2969	41	79	36	8	R45819/64	R45719/64
	7.60	0.2992	41	79	36	8	R4587.6	R4577.6
N	7.67	0.3020	41	79	36	8	R458N	R457N
	7.70	0.3031	41	79	36	8	R4587.7	R4577.7
	7.80	0.3071	41	79	36	8	R4587.8	R4577.8
	7.90	0.3110	41	79	36	8	R4587.9	R4577.9
5/16	7.94	0.3126	41	79	36	8	R4585/16	R4575/16
	8.00	0.3150	41	79	36	8	R4588.0	R4578.0
O	8.03	0.3161	47	89	40	10	R458O	R457O
	8.05	0.3169	47	89	40	10		R4578.05
	8.10	0.3189	47	89	40	10	R4588.1	R4578.1
	8.20	0.3228	47	89	40	10	R4588.2	R4578.2
P	8.20	0.3228	47	89	40	10	R458P	R457P
	8.30	0.3268	47	89	40	10	R4588.3	R4578.3
21/64	8.33	0.3280	47	89	40	10	R45821/64	R45721/64
	8.40	0.3307	47	89	40	10	R4588.4	R4578.4
Q	8.43	0.3319	47	89	40	10	R458Q	R457Q
	8.50	0.3346	47	89	40	10	R4588.5	R4578.5
	8.60	0.3386	47	89	40	10	R4588.6	R4578.6
R	8.61	0.3390	47	89	40	10	R458R	R457R
	8.70	0.3425	47	89	40	10	R4588.7	R4578.7
11/32	8.73	0.3437	47	89	40	10	R45811/32	R45711/32
	8.80	0.3465	47	89	40	10	R4588.8	R4578.8
S	8.84	0.3480	47	89	40	10	R458S	R457S
	8.90	0.3504	47	89	40	10	R4588.9	R4578.9
	9.00	0.3543	47	89	40	10	R4589.0	R4579.0
T	9.09	0.3579	47	89	40	10	R458T	R457T
	9.10	0.3583	47	89	40	10	R4589.1	R4579.1
23/64	9.13	0.3594	47	89	40	10	R45823/64	R45723/64
	9.20	0.3622	47	89	40	10	R4589.2	R4579.2
	9.30	0.3661	47	89	40	10	R4589.3	R4579.3
U	9.35	0.3681	47	89	40	10	R458U	R457U
	9.40	0.3701	47	89	40	10	R4589.4	R4579.4
	9.50	0.3740	47	89	40	10	R4589.5	R4579.5
3/8	9.52	0.3748	47	89	40	10	R4583/8	R4573/8
V	9.58	0.3772	47	89	40	10	R458V	R457V
	9.60	0.3780	47	89	40	10	R4589.6	R4579.6
	9.70	0.3819	47	89	40	10	R4589.7	R4579.7
	9.80	0.3858	47	89	40	10	R4589.8	R4579.8
W	9.80	0.3858	47	89	40	10	R458W	R457W
	9.90	0.3898	47	89	40	10	R4589.9	R4579.9
25/64	9.92	0.3906	47	89	40	10	R45825/64	R45725/64
	10.00	0.3937	47	89	40	10	R45810.0	R45710.0
	10.05	0.3957	55	102	45	12		R45710.05
X	10.08	0.3969	55	102	45	12	R458X	R457X
	10.10	0.3976	55	102	45	12	R45810.1	R45710.1
	10.20	0.4016	55	102	45	12	R45810.2	R45710.2
Y	10.26	0.4039	55	102	45	12	R458Y	R457Y
	10.30	0.4055	55	102	45	12	R45810.3	R45710.3
13/32	10.32	0.4063	55	102	45	12	R45813/32	R45713/32
	10.40	0.4094	55	102	45	12	R45810.4	R45710.4
Z	10.49	0.4130	55	102	45	12	R458Z	R457Z
	10.50	0.4134	55	102	45	12	R45810.5	R45710.5
	10.60	0.4173	55	102	45	12	R45810.6	R45710.6
	10.70	0.4213	55	102	45	12	R45810.7	
27/64	10.72	0.4220	55	102	45	12	R45827/64	R45727/64
	10.80	0.4252	55	102	45	12	R45810.8	R45710.8
	10.90	0.4291	55	102	45	12	R45810.9	
	11.00	0.4331	55	102	45	12	R45811.0	R45711.0
	11.10	0.4370	55	102	45	12	R45811.1	

d_1 Ø "/Nr.	d_1 Ø _{m7} mm	d_1 decimal Inch	l_2 mm	l_1 mm	l_3 mm	d_2 Ø _{h6} mm	R458	R457
7/16	11.11	0.4374	55	102	45	12	R4587/16	R4577/16
	11.20	0.4409	55	102	45	12	R45811.2	R45711.2
	11.30	0.4449	55	102	45	12	R45811.3	R45711.3
	11.40	0.4488	55	102	45	12	R45811.4	R45711.4
29/64	11.50	0.4528	55	102	45	12	R45811.5	R45711.5
	11.51	0.4531	55	102	45	12	R45829/64	R45729/64
	11.60	0.4567	55	102	45	12	R45811.6	R45711.6
	11.70	0.4606	55	102	45	12	R45811.7	
	11.80	0.4646	55	102	45	12	R45811.8	R45711.8
15/32	11.90	0.4685	55	102	45	12	R45811.9	
	11.91	0.4689	55	102	45	12	R45815/32	R45715/32
	12.00	0.4724	55	102	45	12	R45812.0	R45712.0
	12.05	0.4744	60	107	45	14		R45712.05
31/64	12.10	0.4764	60	107	45	14	R45812.1	R45712.1
	12.20	0.4803	60	107	45	14	R45812.2	R45712.2
	12.30	0.4843	60	107	45	14	R45831/64	R45731/64
	12.50	0.4921	60	107	45	14	R45812.5	R45712.5
1/2	12.70	0.5000	60	107	45	14	R45812.7	R45712.7
	12.70	0.5000	60	107	45	14	R4581/2	R4571/2
	12.80	0.5039	60	107	45	14	R45812.8	R45712.8
33/64	13.00	0.5118	60	107	45	14	R45813.0	R45713.0
	13.10	0.5157	60	107	45	14	R45833/64	R45733/64
	13.30	0.5236	60	107	45	14	R45813.3	R45713.3
17/32	13.49	0.5311	60	107	45	14	R45817/32	R45717/32
	13.50	0.5315	60	107	45	14	R45813.5	R45713.5
	13.80	0.5433	60	107	45	14	R45813.8	R45713.8
35/64	13.89	0.5469	60	107	45	14	R45835/64	R45735/64
	14.00	0.5512	60	107	45	14	R45814.0	R45714.0
	14.25	0.5610	65	115	48	16	R45814.25	R45714.25
9/16	14.29	0.5626	65	115	48	16	R4589/16	R4579/16
	14.50	0.5709	65	115	48	16	R45814.5	R45714.5
37/64	14.68	0.5780	65	115	48	16	R45837/64	R45737/64
	14.80	0.5827	65	115	48	16	R45814.8	R45714.8
	15.00	0.5906	65	115	48	16	R45815.0	R45715.0
19/32	15.08	0.5937	65	115	48	16	R45819/32	R45719/32
	15.10	0.5945	65	115	48	16	R45815.1	R45715.1
	15.30	0.6024	65	115	48	16	R45815.3	R45715.3
39/64	15.48	0.6094	65	115	48	16	R45839/64	R45739/64
	15.50	0.6102	65	115	48	16	R45815.5	R45715.5
	15.80	0.6220	65	115	48	16	R45815.8	R45715.8
5/8	15.88	0.6252	65	115	48	16	R4585/8	R4575/8
	16.00	0.6299	65	115	48	16	R45816.0	R45716.0
41/64	16.27	0.6406	73	123	48	18	R45841/64	R45741/64
	16.50	0.6496	73	123	48	18	R45816.5	R45716.5
21/32	16.67	0.6563	73	123	48	18	R45821/32	R45721/32
	17.00	0.6693	73	123	48	18	R45817.0	R45717.0
43/64	17.07	0.6720	73	123	48	18	R45843/64	R45743/64
11/16	17.46	0.6874	73	123	48	18	R45811/16	R45711/16
	17.50	0.6890	73	123	48	18	R45817.5	R45717.5
	17.80	0.7008	73	123	48	18	R45817.8	
45/64	17.86	0.7031	73	123	48	18	R45845/64	R45745/64
	18.00	0.7087	73	123	48	18	R45818.0	R45718.0
	18.26	0.7189	79	131	50	20	R45823/32	R45723/32
23/32	18.50	0.7283	79	131	50	20	R45818.5	R45718.5
	18.65	0.7343	79	131	50	20	R45847/64	R45747/64
47/64	18.80	0.7402	79	131	50	20		R45718.8
	19.00	0.7480	79	131	50	20	R45819.0	R45719.0
	19.05	0.7500	79	131	50	20	R4583/4	R4573/4
	19.50	0.7677	79	131	50	20	R45819.5	R45719.5
3/4	19.80	0.7795	79	131	50	20	R45819.8	R45719.8
	20.00	0.7874	79	131	50	20	R45820.0	R45720.0

R454

- Punta Force-X Serie lunga 5XD
- Force-X Spiralbohrer, lang 5XD
- Force-X Spiraalboor 5XD
- Foret série longue Force-X 5XD

R453

- Punta Force-X con fori di lubrificazione 5XD
- Force-X Spiralbohrer - Kühlkanal 5XD
- Force-X Spiraalboor met koelkanalen 5XD
- Foret Force-X - à trous d'huile 5XD

R454	▪	1.1	1.2	1.3	1.4	1.5	1.6	1.7	1.8	2.1	2.2	2.3	3.1	3.2	3.3	3.4	6.1	6.2	6.3	7.1	7.2
		7.3	7.4																		
	•	2.4	4.1	4.2	4.3	6.4															
R453	▪	1.1	1.2	1.3	1.4	1.5	1.6	1.7	1.8	2.1	2.2	3.1	3.2	3.3	3.4	4.1	4.2	4.3	6.1	6.2	6.3
		6.4	7.1	7.2	7.3	7.4															
	•	2.3	2.4																		

R454	HM	DIN 6537 L	5XD	140°	TiAIN	DIN 6535HA	GTW™		
R453	HM	DIN 6537 L	5XD	140°	TiAIN	DIN 6535HA	GTW™		

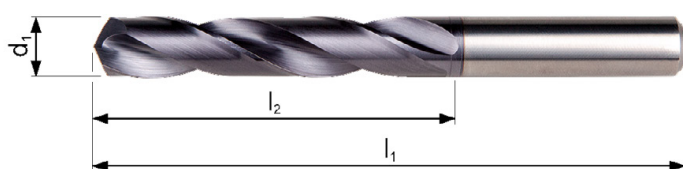

d_1 Ø Inch	d_1 Ø _{m7} mm	d_1 decimal Inch	l_2 mm	l_1 mm	l_3 mm	d_2 Ø _{h6} mm	R454	R453
	3.00	0.1181	28	66	36	6	R4543.0	R4533.0
	3.10	0.1220	28	66	36	6	R4543.1	R4533.1
1/8	3.18	0.1252	28	66	36	6	R4541/8	R4531/8
	3.20	0.1260	28	66	36	6	R4543.2	R4533.2
30	3.26	0.1283	28	66	36	6	R454N30	R453N30
	3.30	0.1299	28	66	36	6	R4543.3	R4533.3
	3.40	0.1339	28	66	36	6	R4543.4	R4533.4
29	3.45	0.1358	28	66	36	6	R454N29	R453N29
	3.50	0.1378	28	66	36	6	R4543.5	R4533.5
28	3.57	0.1406	28	66	36	6	R454N28	R453N28
9/64	3.57	0.1406	28	66	36	6	R4549/64	R4539/64
	3.60	0.1417	28	66	36	6	R4543.6	R4533.6
27	3.66	0.1441	28	66	36	6	R454N27	R453N27
	3.70	0.1457	28	66	36	6	R4543.7	R4533.7
26	3.73	0.1469	36	74	36	6	R454N26	R453N26
	3.80	0.1496	36	74	36	6	R4543.8	R4533.8
25	3.80	0.1496	36	74	36	6	R454N25	R453N25
24	3.86	0.1520	36	74	36	6	R454N24	R453N24
	3.90	0.1535	36	74	36	6	R4543.9	R4533.9
23	3.91	0.1539	36	74	36	6	R454N23	R453N23
5/32	3.97	0.1563	36	74	36	6	R4545/32	R4535/32
22	3.99	0.1571	36	74	36	6	R454N22	R453N22

d ₁ Ø Inch	d ₁ Øm ₇ mm	d ₁ decimal Inch	l ₂ mm	l ₁ mm	l ₃ mm	d ₂ Øh ₆ mm	R454	R453
	4.00	0.1575	36	74	36	6	R4544.0	R4534.0
21	4.04	0.1591	36	74	36	6	R454N21	R453N21
	4.05	0.1594	36	74	36	6		R4534.05
20	4.09	0.1610	36	74	36	6	R454N20	R453N20
	4.10	0.1614	36	74	36	6	R4544.1	R4534.1
	4.20	0.1654	36	74	36	6	R4544.2	R4534.2
19	4.22	0.1661	36	74	36	6	R454N19	R453N19
	4.30	0.1693	36	74	36	6	R4544.3	R4534.3
18	4.31	0.1697	36	74	36	6	R454N18	R453N18
11/64	4.37	0.1720	36	74	36	6	R45411/64	R45311/64
17	4.39	0.1728	36	74	36	6	R454N17	R453N17
	4.40	0.1732	36	74	36	6	R4544.4	R4534.4
	4.50	0.1772	36	74	36	6	R4544.5	R4534.5
16	4.50	0.1772	36	74	36	6	R454N16	R453N16
15	4.57	0.1799	36	74	36	6	R454N15	R453N15
	4.60	0.1811	36	74	36	6	R4544.6	R4534.6
14	4.62	0.1819	36	74	36	6	R454N14	R453N14
	4.70	0.1850	36	74	36	6	R4544.7	R4534.7
13	4.70	0.1850	36	74	36	6	R454N13	R453N13
3/16	4.76	0.1874	44	82	36	6	R4543/16	R4533/16
	4.80	0.1890	44	82	36	6	R4544.8	R4534.8
12	4.80	0.1890	44	82	36	6	R454N12	R453N12
11	4.85	0.1909	44	82	36	6	R454N11	R453N11
	4.90	0.1929	44	82	36	6	R4544.9	R4534.9
10	4.92	0.1937	44	82	36	6	R454N10	R453N10
9	4.98	0.1961	44	82	36	6	R454N9	R453N9
	5.00	0.1969	44	82	36	6	R4545.0	R4535.0
	5.05	0.1988	44	82	36	6		R4535.05
8	5.06	0.1992	44	82	36	6	R454N8	R453N8
	5.10	0.2008	44	82	36	6	R4545.1	R4535.1
7	5.11	0.2012	44	82	36	6	R454N7	R453N7
13/64	5.16	0.2031	44	82	36	6	R45413/64	R45313/64
6	5.18	0.2039	44	82	36	6	R454N6	R453N6
	5.20	0.2047	44	82	36	6	R4545.2	R4535.2
5	5.22	0.2055	44	82	36	6	R454N5	R453N5
	5.30	0.2087	44	82	36	6		R4535.3
4	5.31	0.2091	44	82	36	6	R454N4	R453N4
	5.40	0.2126	44	82	36	6		R4535.4
3	5.41	0.2130	44	82	36	6	R454N3	R453N3
	5.50	0.2165	44	82	36	6	R4545.5	R4535.5
7/32	5.56	0.2189	44	82	36	6	R4547/32	R4537/32
	5.60	0.2205	44	82	36	6	R4545.6	R4535.6
2	5.61	0.2209	44	82	36	6	R454N2	R453N2
	5.70	0.2244	44	82	36	6	R4545.7	R4535.7
1	5.79	0.2280	44	82	36	6	R454N1	R453N1
	5.80	0.2283	44	82	36	6	R4545.8	R4535.8
	5.90	0.2323	44	82	36	6	R4545.9	R4535.9
A	5.94	0.2339	44	82	36	6	R454A	R453A
15/64	5.95	0.2343	44	82	36	6	R45415/64	R45315/64
	6.00	0.2362	44	82	36	6	R4546.0	R4536.0
B	6.03	0.2374	53	91	36	8	R454B	R453B
	6.05	0.2382	53	91	36	8		R4536.05
	6.10	0.2402	53	91	36	8	R4546.1	R4536.1
C	6.15	0.2421	53	91	36	8	R454C	R453C
	6.20	0.2441	53	91	36	8	R4546.2	R4536.2
D	6.25	0.2461	53	91	36	8	R454D	R453D
	6.30	0.2480	53	91	36	8	R4546.3	R4536.3
1/4	6.35	0.2500	53	91	36	8	R4541/4	R4531/4
E	6.35	0.2500	53	91	36	8	R454E	R453E
	6.40	0.2520	53	91	36	8	R4546.4	R4536.4
	6.50	0.2559	53	91	36	8	R4546.5	R4536.5
F	6.53	0.2571	53	91	36	8	R454F	R453F
	6.60	0.2598	53	91	36	8	R4546.6	R4536.6
G	6.63	0.2610	53	91	36	8	R454G	R453G
	6.70	0.2638	53	91	36	8	R4546.7	R4536.7
17/64	6.75	0.2657	53	91	36	8	R45417/64	R45317/64
H	6.76	0.2661	53	91	36	8	R454H	R453H
	6.80	0.2677	53	91	36	8	R4546.8	R4536.8
	6.90	0.2717	53	91	36	8	R4546.9	R4536.9

d ₁ Ø Inch	d ₁ Øm ₁ mm	d ₁ decimal Inch	l ₂ mm	l ₁ mm	l ₃ mm	d ₂ Øh _s mm	R454	R453
I	6.91	0.2720	53	91	36	8	R454I	R453I
	7.00	0.2756	53	91	36	8	R4547.0	R4537.0
J	7.04	0.2772	53	91	36	8	R454J	R453J
	7.10	0.2795	53	91	36	8	R4547.1	R4537.1
K	7.14	0.2811	53	91	36	8	R454K	R453K
9/32	7.14	0.2811	53	91	36	8	R4549/32	R4539/32
	7.20	0.2835	53	91	36	8		R4537.2
	7.30	0.2874	53	91	36	8	R4547.3	R4537.3
L	7.37	0.2902	53	91	36	8	R454L	R453L
	7.40	0.2913	53	91	36	8	R4547.4	R4537.4
M	7.49	0.2949	53	91	36	8	R454M	R453M
	7.50	0.2953	53	91	36	8	R4547.5	R4537.5
19/64	7.54	0.2969	53	91	36	8	R45419/64	R45319/64
	7.60	0.2992	53	91	36	8	R4547.6	R4537.6
N	7.67	0.3020	53	91	36	8	R454N	R453N
	7.70	0.3031	53	91	36	8	R4547.7	R4537.7
	7.80	0.3071	53	91	36	8	R4547.8	R4537.8
	7.90	0.3110	53	91	36	8	R4547.9	R4537.9
5/16	7.94	0.3126	53	91	36	8	R4545/16	R4535/16
	8.00	0.3150	53	91	36	8	R4548.0	R4538.0
O	8.03	0.3161	61	103	40	10	R454O	R453O
	8.05	0.3169	61	103	40	10		R4538.05
	8.10	0.3189	61	103	40	10	R4548.1	R4538.1
	8.20	0.3228	61	103	40	10	R4548.2	R4538.2
P	8.20	0.3228	61	103	40	10	R454P	R453P
	8.30	0.3268	61	103	40	10		R4538.3
21/64	8.33	0.3280	61	103	40	10	R45421/64	R45321/64
	8.40	0.3307	61	103	40	10	R4548.4	R4538.4
Q	8.43	0.3319	61	103	40	10	R454Q	R453Q
	8.50	0.3346	61	103	40	10	R4548.5	R4538.5
	8.60	0.3386	61	103	40	10	R4548.6	R4538.6
R	8.61	0.3390	61	103	40	10	R454R	R453R
	8.70	0.3425	61	103	40	10	R4548.7	R4538.7
11/32	8.73	0.3437	61	103	40	10	R45411/32	R45311/32
	8.80	0.3465	61	103	40	10	R4548.8	R4538.8
S	8.84	0.3480	61	103	40	10	R454S	R453S
	8.90	0.3504	61	103	40	10	R4548.9	R4538.9
	9.00	0.3543	61	103	40	10	R4549.0	R4539.0
T	9.09	0.3579	61	103	40	10	R454T	R453T
	9.10	0.3583	61	103	40	10	R4549.1	R4539.1
23/64	9.13	0.3594	61	103	40	10	R45423/64	R45323/64
	9.20	0.3622	61	103	40	10		R4539.2
	9.30	0.3661	61	103	40	10	R4549.3	R4539.3
U	9.35	0.3681	61	103	40	10	R454U	R453U
	9.40	0.3701	61	103	40	10	R4549.4	R4539.4
	9.50	0.3740	61	103	40	10	R4549.5	R4539.5
3/8	9.52	0.3748	61	103	40	10	R4543/8	R4533/8
V	9.58	0.3772	61	103	40	10	R454V	R453V
	9.60	0.3780	61	103	40	10	R4549.6	R4539.6
	9.70	0.3819	61	103	40	10	R4549.7	R4539.7
	9.80	0.3858	61	103	40	10	R4549.8	R4539.8
W	9.80	0.3858	61	103	40	10	R454W	R453W
	9.90	0.3898	61	103	40	10	R4549.9	R4539.9
25/64	9.92	0.3906	61	103	40	10	R45425/64	R45325/64
	10.00	0.3937	61	103	40	10	R45410.0	R45310.0
	10.05	0.3957	70	118	45	12		R45310.05
X	10.08	0.3969	70	118	45	12	R454X	R453X
	10.10	0.3976	70	118	45	12	R45410.1	R45310.1
	10.20	0.4016	70	118	45	12	R45410.2	R45310.2
Y	10.26	0.4039	70	118	45	12	R454Y	R453Y
	10.30	0.4055	70	118	45	12	R45410.3	R45310.3
13/32	10.32	0.4063	70	118	45	12	R45413/32	R45313/32
	10.40	0.4094	70	118	45	12	R45410.4	R45310.4
Z	10.49	0.4130	70	118	45	12	R454Z	R453Z
	10.50	0.4134	70	118	45	12	R45410.5	R45310.5
	10.60	0.4173	70	118	45	12	R45410.6	R45310.6
27/64	10.72	0.4220	70	118	45	12	R45427/64	R45327/64
	10.80	0.4252	70	118	45	12		R45310.8
	11.00	0.4331	70	118	45	12	R45411.0	R45311.0
7/16	11.11	0.4374	70	118	45	12	R4547/16	R4537/16

d ₁ Ø Inch	d ₁ Øm ₇ mm	d ₁ decimal Inch	l ₂ mm	l ₁ mm	l ₃ mm	d ₂ Øh ₆ mm	R454	R453
	11.20	0.4409	70	118	45	12	R45411.2	R45311.2
	11.30	0.4449	70	118	45	12		R45311.3
	11.40	0.4488	70	118	45	12	R45411.4	R45311.4
	11.50	0.4528	70	118	45	12	R45411.5	R45311.5
29/64	11.51	0.4531	70	118	45	12	R45429/64	R45329/64
	11.60	0.4567	70	118	45	12	R45411.6	R45311.6
	11.80	0.4646	70	118	45	12	R45411.8	R45311.8
15/32	11.91	0.4689	70	118	45	12	R45415/32	R45315/32
	12.00	0.4724	70	118	45	12	R45412.0	R45312.0
	12.05	0.4744	76	124	45	14		R45312.05
	12.10	0.4764	76	124	45	14	R45412.1	
	12.20	0.4803	76	124	45	14	R45412.2	R45312.2
31/64	12.30	0.4843	76	124	45	14	R45431/64	R45331/64
	12.50	0.4921	76	124	45	14	R45412.5	R45312.5
	12.70	0.5000	76	124	45	14	R45412.7	R45312.7
1/2	12.70	0.5000	76	124	45	14	R4541/2	R4531/2
	12.80	0.5039	76	124	45	14	R45412.8	R45312.8
	13.00	0.5118	76	124	45	14	R45413.0	R45313.0
33/64	13.10	0.5157	76	124	45	14	R45433/64	R45333/64
	13.30	0.5236	76	124	45	14		R45313.3
17/32	13.49	0.5311	76	124	45	14	R45417/32	R45317/32
	13.50	0.5315	76	124	45	14	R45413.5	R45313.5
	13.80	0.5433	76	124	45	14	R45413.8	R45313.8
35/64	13.89	0.5469	76	124	45	14	R45435/64	R45335/64
	14.00	0.5512	76	124	45	14	R45414.0	R45314.0
	14.25	0.5610	82	133	48	16	R45414.25	R45314.25
9/16	14.29	0.5626	82	133	48	16	R4549/16	R4539/16
	14.50	0.5709	82	133	48	16	R45414.5	R45314.5
37/64	14.68	0.5780	82	133	48	16	R45437/64	R45337/64
	14.80	0.5827	82	133	48	16	R45414.8	R45314.8
	15.00	0.5906	82	133	48	16	R45415.0	R45315.0
19/32	15.08	0.5937	82	133	48	16	R45419/32	R45319/32
	15.10	0.5945	82	133	48	16	R45415.1	R45315.1
	15.30	0.6024	82	133	48	16		R45315.3
39/64	15.48	0.6094	82	133	48	16	R45439/64	R45339/64
	15.50	0.6102	82	133	48	16	R45415.5	R45315.5
	15.80	0.6220	82	133	48	16	R45415.8	R45315.8
5/8	15.88	0.6252	82	133	48	16	R4545/8	R4535/8
	16.00	0.6299	82	133	48	16	R45416.0	R45316.0
41/64	16.27	0.6406	91	143	48	18	R45441/64	R45341/64
	16.50	0.6496	91	143	48	18	R45416.5	R45316.5
21/32	16.67	0.6563	91	143	48	18	R45421/32	R45321/32
	17.00	0.6693	91	143	48	18	R45417.0	R45317.0
43/64	17.07	0.6720	91	143	48	18	R45443/64	R45343/64
11/16	17.46	0.6874	91	143	48	18	R45411/16	R45311/16
	17.50	0.6890	91	143	48	18	R45417.5	R45317.5
	17.80	0.7008	91	143	48	18	R45417.8	R45317.8
45/64	17.86	0.7031	91	143	48	18	R45445/64	R45345/64
	18.00	0.7087	91	143	48	18	R45418.0	R45318.0
23/32	18.26	0.7189	99	153	50	20	R45423/32	R45323/32
	18.50	0.7283	99	153	50	20	R45418.5	R45318.5
47/64	18.65	0.7343	99	153	50	20	R45447/64	R45347/64
	19.00	0.7480	99	153	50	20	R45419.0	R45319.0
3/4	19.05	0.7500	99	153	50	20	R4543/4	R4533/4
	19.50	0.7677	99	153	50	20	R45419.5	R45319.5
	19.80	0.7795	99	153	50	20	R45419.8	R45319.8
	20.00	0.7874	99	153	50	20	R45420.0	R45320.0

R459

- Punta Force-X con fori di lubrificazione 8XD
- Force-X Spiralbohrer - Kühlkanal 8XD
- Force-X Spiraalboor met koelkanalen 8XD
- Foret Force-X - à trous d'huile 8XD

R459	▪	1.1	1.2	1.3	1.4	1.5	1.6	2.1	2.2	3.1	3.2	3.3	3.4	7.2	7.3
	•	2.3	6.1	6.2	6.3	6.4	7.1								

R459

HM

DORMER

8XD

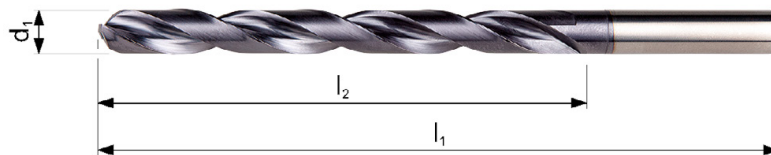

R459



FORCE X

3.00 - 16.00

d_1 \varnothing_{m_7} Inch	d_1 \varnothing_{m_7} mm	d_1 decimal Inch	l_2 mm	l_1 mm	l_3 mm	d_2 \varnothing_{h_6} mm	R459
	3.00	0.1181	37	79	36	6	R4593.0
	3.10	0.1220	37	79	36	6	R4593.1
1/8	3.18	0.1252	37	79	36	6	R4591/8
	3.20	0.1260	37	79	36	6	R4593.2
	3.30	0.1299	37	79	36	6	R4593.3
	3.40	0.1339	37	79	36	6	R4593.4
	3.50	0.1378	37	79	36	6	R4593.5
9/64	3.57	0.1406	37	79	36	6	R4599/64
	3.60	0.1417	37	79	36	6	R4593.6
	3.70	0.1457	37	79	36	6	R4593.7
	3.80	0.1496	48	90	36	6	R4593.8
	3.90	0.1535	48	90	36	6	R4593.9
5/32	3.97	0.1563	48	90	36	6	R4595/32
	4.00	0.1575	48	90	36	6	R4594.0
	4.10	0.1614	48	90	36	6	R4594.1
	4.20	0.1654	48	90	36	6	R4594.2
	4.30	0.1693	48	90	36	6	R4594.3
11/64	4.37	0.1720	48	90	36	6	R45911/64
	4.40	0.1732	48	90	36	6	R4594.4
	4.50	0.1772	48	90	36	6	R4594.5
	4.60	0.1811	48	90	36	6	R4594.6
	4.70	0.1850	62	104	36	6	R4594.7
3/16	4.76	0.1874	62	104	36	6	R4593/16
	4.80	0.1890	62	104	36	6	R4594.8
	4.90	0.1929	62	104	36	6	R4594.9
	5.00	0.1969	62	104	36	6	R4595.0
	5.10	0.2008	62	104	36	6	R4595.1
13/64	5.16	0.2031	62	104	36	6	R45913/64
	5.20	0.2047	62	104	36	6	R4595.2
	5.30	0.2087	62	104	36	6	R4595.3
	5.40	0.2126	62	104	36	6	R4595.4
	5.50	0.2165	62	104	36	6	R4595.5
7/32	5.56	0.2189	62	104	36	6	R4597/32
	5.60	0.2205	62	104	36	6	R4595.6
	5.70	0.2244	62	104	36	6	R4595.7
	5.80	0.2283	62	104	36	6	R4595.8

d_1 $\varnothing m_7$ Inch	d_1 $\varnothing m_7$ mm	d_1 decimal Inch	l_2 mm	l_1 mm	l_3 mm	d_2 $\varnothing h_6$ mm	R459
	5.90	0.2323	62	104	36	6	R4595.9
15/64	5.95	0.2343	62	104	36	6	R45915/64
	6.00	0.2362	62	104	36	6	R4596.0
	6.10	0.2402	84	126	36	8	R4596.1
	6.20	0.2441	84	126	36	8	R4596.2
	6.30	0.2480	84	126	36	8	R4596.3
1/4	6.35	0.2500	84	126	36	8	R4591/4
	6.40	0.2520	84	126	36	8	R4596.4
	6.50	0.2559	84	126	36	8	R4596.5
	6.60	0.2598	84	126	36	8	R4596.6
	6.70	0.2638	84	126	36	8	R4596.7
17/64	6.75	0.2657	84	126	36	8	R45917/64
	6.80	0.2677	84	126	36	8	R4596.8
	6.90	0.2717	84	126	36	8	R4596.9
	7.00	0.2756	84	126	36	8	R4597.0
	7.10	0.2795	84	126	36	8	R4597.1
9/32	7.14	0.2811	84	126	36	8	R4599/32
	7.20	0.2835	84	126	36	8	R4597.2
	7.30	0.2874	84	126	36	8	R4597.3
	7.40	0.2913	84	126	36	8	R4597.4
	7.50	0.2953	84	126	36	8	R4597.5
19/64	7.54	0.2969	84	126	36	8	R45919/64
	7.60	0.2992	84	126	36	8	R4597.6
	7.70	0.3031	84	126	36	8	R4597.7
	7.80	0.3071	84	126	36	8	R4597.8
	7.90	0.3110	84	126	36	8	R4597.9
5/16	7.94	0.3126	84	126	36	8	R4595/16
	8.00	0.3150	84	126	36	8	R4598.0
	8.10	0.3189	106	152	40	10	R4598.1
	8.20	0.3228	106	152	40	10	R4598.2
	8.30	0.3268	106	152	40	10	R4598.3
21/64	8.33	0.3280	106	152	40	10	R45921/64
	8.40	0.3307	106	152	40	10	R4598.4
	8.50	0.3346	106	152	40	10	R4598.5
	8.60	0.3386	106	152	40	10	R4598.6
	8.70	0.3425	106	152	40	10	R4598.7
11/32	8.73	0.3437	106	152	40	10	R45911/32
	8.80	0.3465	106	152	40	10	R4598.8
	8.90	0.3504	106	152	40	10	R4598.9
	9.00	0.3543	106	152	40	10	R4599.0
	9.10	0.3583	106	152	40	10	R4599.1
23/64	9.13	0.3594	106	152	40	10	R45923/64
	9.20	0.3622	106	152	40	10	R4599.2
	9.30	0.3661	106	152	40	10	R4599.3
	9.40	0.3701	106	152	40	10	R4599.4
	9.50	0.3740	106	152	40	10	R4599.5
3/8	9.53	0.3748	106	152	40	10	R4593/8
	9.60	0.3780	106	152	40	10	R4599.6
	9.70	0.3819	106	152	40	10	R4599.7
	9.80	0.3858	106	152	40	10	R4599.8
	9.90	0.3898	106	152	40	10	R4599.9
25/64	9.92	0.3906	106	152	40	10	R45925/64
	10.00	0.3937	106	152	40	10	R45910.0
	10.20	0.4016	128	180	45	12	R45910.2
	10.30	0.4055	128	180	45	12	R45910.3
13/32	10.32	0.4063	128	180	45	12	R45913/32
	10.40	0.4094	128	180	45	12	R45910.4
	10.50	0.4134	128	180	45	12	R45910.5
27/64	10.72	0.4220	128	180	45	12	R45927/64
	10.80	0.4252	128	180	45	12	R45910.8
	11.00	0.4331	128	180	45	12	R45911.0
7/16	11.11	0.4374	128	180	45	12	R4597/16
	11.20	0.4409	128	180	45	12	R45911.2
	11.30	0.4449	128	180	45	12	R45911.3
	11.50	0.4528	128	180	45	12	R45911.5
29/64	11.51	0.4531	128	180	45	12	R45929/64
	11.80	0.4646	128	180	45	12	R45911.8
15/32	11.91	0.4689	128	180	45	12	R45915/32
	12.00	0.4724	128	180	45	12	R45912.0
	12.20	0.4803	151	202	48	14	R45912.2

d_1 $\varnothing m_7$ Inch	d_1 $\varnothing m_7$ mm	d_1 decimal Inch	l_2 mm	l_1 mm	l_3 mm	d_2 $\varnothing h_6$ mm	R459
31/64	12.30	0.4843	151	202	48	14	R45931/64
	12.50	0.4921	151	202	48	14	R45912.5
1/2	12.70	0.5000	151	202	48	14	R4591/2
	12.80	0.5039	151	202	48	14	R45912.8
	13.00	0.5118	151	202	48	14	R45913.0
33/64	13.10	0.5157	151	202	48	14	R45933/64
17/32	13.49	0.5311	151	202	48	14	R45917/32
	13.50	0.5315	151	202	48	14	R45913.5
35/64	13.89	0.5469	151	202	48	14	R45935/64
	14.00	0.5512	151	202	48	14	R45914.0
	14.25	0.5610	172	227	48	16	R45914.25
	14.29	0.5626	172	227	48	16	R4599/16
9/16	14.50	0.5709	172	227	48	16	R45914.5
	14.68	0.5780	172	227	48	16	R45937/64
37/64	15.00	0.5906	172	227	48	16	R45915.0
	15.08	0.5937	172	227	48	16	R45919/32
19/32	15.10	0.5945	172	227	48	16	R45915.1
	15.48	0.6094	172	227	48	16	R45939/64
39/64	15.50	0.6102	172	227	48	16	R45915.5
	15.88	0.6252	172	227	48	16	R4595/8
5/8	16.00	0.6299	172	227	48	16	R45916.0

R467

- Punta Force M con fori di lubrificazione 3×D
- Force M Spiralbohrer, Kühlkanal 3×D
- Force M Spiraalboor met koelkanalen 3×D
- Foret Force M, à trous d'huile 3×D

R467 ■ 2.1 2.2 2.3 2.4 4.1 4.2 4.3
 • 5.1 5.2 5.3

R467

HM
DIN 6537 K
3XD
140°
TiAIN
DIN 6535HA
CTW™

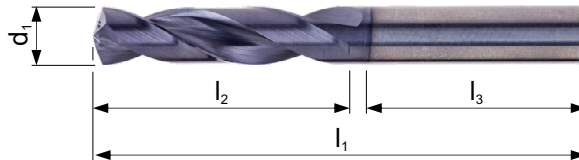

d ₁ Ø "/Nr./letter	d ₁ Øm ₇ mm	d ₁ decimal Inch	l ₂ mm	l ₁ mm	l ₃ mm	d ₂ Øh ₆ mm	R467
1/8	3.00	0.1181	20	62	36	6	R4673.0
	3.10	0.1220	20	62	36	6	R4673.1
	3.18	0.1250	20	62	36	6	R4671/8
	3.20	0.1260	20	62	36	6	R4673.2
	3.30	0.1299	20	62	36	6	R4673.3
29	3.40	0.1339	20	62	36	6	R4673.4
	3.45	0.1360	20	62	36	6	R467N29
	3.50	0.1378	20	62	36	6	R4673.5
	3.57	0.1406	20	62	36	6	R4679/64
9/64	3.60	0.1417	20	62	36	6	R4673.6
	3.70	0.1457	20	62	36	6	R4673.7
	3.80	0.1496	24	66	36	6	R4673.8
	3.90	0.1535	24	66	36	6	R4673.9
	3.97	0.1563	24	66	36	6	R4675/32
	4.00	0.1575	24	66	36	6	R4674.0
	4.05	0.1594	24	66	36	6	R4674.05
	4.10	0.1614	24	66	36	6	R4674.1
	4.20	0.1654	24	66	36	6	R4674.2
	4.30	0.1693	24	66	36	6	R4674.3
11/64	4.37	0.1719	24	66	36	6	R46711/64
	4.40	0.1732	24	66	36	6	R4674.4
	4.50	0.1772	24	66	36	6	R4674.5
	4.60	0.1811	24	66	36	6	R4674.6
	4.70	0.1850	24	66	36	6	R4674.7
	3/16	4.76	0.1875	28	66	36	6
4.80		0.1890	28	66	36	6	R4674.8
4.90		0.1929	28	66	36	6	R4674.9
5.00		0.1969	28	66	36	6	R4675.0
5.05		0.1988	28	66	36	6	R4675.05
5.10		0.2008	28	66	36	6	R4675.1
7	5.11	0.2010	28	66	36	6	R467N7
13/64	5.16	0.2031	28	66	36	6	R46713/64
	5.20	0.2047	28	66	36	6	R4675.2
5	5.22	0.2055	28	66	36	6	R467N5
	5.30	0.2087	28	66	36	6	R4675.3
	5.40	0.2126	28	66	36	6	R4675.4
	5.50	0.2165	28	66	36	6	R4675.5
	7/32	5.56	0.2188	28	66	36	6

d_1 Ø "Nr./letter	d_1 Ø _{m7} mm	d_1 decimal Inch	l_2 mm	l_1 mm	l_3 mm	d_2 Ø _{h6} mm	R467
	5.60	0.2205	28	66	36	6	R4675.6
	5.70	0.2244	28	66	36	6	R4675.7
	5.80	0.2283	28	66	36	6	R4675.8
	5.90	0.2323	28	66	36	6	R4675.9
15/64	5.95	0.2344	28	66	36	6	R46715/64
	6.00	0.2362	28	66	36	6	R4676.0
	6.05	0.2382	34	79	36	8	R4676.05
	6.10	0.2402	34	79	36	8	R4676.1
	6.20	0.2441	34	79	36	8	R4676.2
	6.30	0.2480	34	79	36	8	R4676.3
1/4	6.35	0.2500	34	79	36	8	R4671/4
	6.40	0.2520	34	79	36	8	R4676.4
	6.50	0.2559	34	79	36	8	R4676.5
	6.60	0.2598	34	79	36	8	R4676.6
	6.70	0.2638	34	79	36	8	R4676.7
17/64	6.75	0.2656	34	79	36	8	R46717/64
	6.80	0.2677	34	79	36	8	R4676.8
	6.90	0.2717	34	79	36	8	R4676.9
	7.00	0.2756	34	79	36	8	R4677.0
	7.10	0.2795	41	79	36	8	R4677.1
9/32	7.14	0.2813	41	79	36	8	R4679/32
	7.20	0.2835	41	79	36	8	R4677.2
	7.30	0.2874	41	79	36	8	R4677.3
	7.40	0.2913	41	79	36	8	R4677.4
	7.50	0.2953	41	79	36	8	R4677.5
19/64	7.54	0.2969	41	79	36	8	R46719/64
	7.60	0.2992	41	79	36	8	R4677.6
	7.70	0.3031	41	79	36	8	R4677.7
	7.80	0.3071	41	79	36	8	R4677.8
	7.90	0.3110	41	79	36	8	R4677.9
5/16	7.94	0.3125	41	79	36	8	R4675/16
	8.00	0.3150	41	79	36	8	R4678.0
	8.05	0.3169	47	89	40	10	R4678.05
	8.10	0.3189	47	89	40	10	R4678.1
	8.20	0.3228	47	89	40	10	R4678.2
	8.30	0.3268	47	89	40	10	R4678.3
21/64	8.33	0.3281	47	89	40	10	R46721/64
	8.40	0.3307	47	89	40	10	R4678.4
	8.50	0.3346	47	89	40	10	R4678.5
	8.60	0.3386	47	89	40	10	R4678.6
	8.70	0.3425	47	89	40	10	R4678.7
11/32	8.73	0.3438	47	89	40	10	R46711/32
	8.80	0.3465	47	89	40	10	R4678.8
	8.90	0.3504	47	89	40	10	R4678.9
	9.00	0.3543	47	89	40	10	R4679.0
	9.10	0.3583	47	89	40	10	R4679.1
23/64	9.13	0.3594	47	89	40	10	R46723/64
	9.20	0.3622	47	89	40	10	R4679.2
	9.30	0.3661	47	89	40	10	R4679.3
	9.40	0.3701	47	89	40	10	R4679.4
	9.50	0.3740	47	89	40	10	R4679.5
3/8	9.53	0.3750	47	89	40	10	R4673/8
	9.60	0.3780	47	89	40	10	R4679.6
	9.70	0.3819	47	89	40	10	R4679.7
	9.80	0.3858	47	89	40	10	R4679.8
	9.90	0.3898	47	89	40	10	R4679.9
25/64	9.92	0.3906	47	89	40	10	R46725/64
	10.00	0.3937	47	89	40	10	R46710.0
	10.05	0.3957	55	102	45	12	R46710.05
	10.10	0.3976	55	102	45	12	R46710.1
	10.20	0.4016	55	102	45	12	R46710.2
	10.30	0.4055	55	102	45	12	R46710.3
13/32	10.32	0.4063	55	102	45	12	R46713/32
	10.40	0.4094	55	102	45	12	R46710.4
	10.50	0.4134	55	102	45	12	R46710.5
	10.60	0.4173	55	102	45	12	R46710.6
27/64	10.72	0.4219	55	102	45	12	R46727/64
	10.80	0.4252	55	102	45	12	R46710.8
	10.90	0.4291	55	102	45	12	R46710.9
	11.00	0.4331	55	102	45	12	R46711.0

d_1 \emptyset "/Nr./letter	d_1 $\emptyset m_7$ mm	d_1 decimal Inch	l_2 mm	l_1 mm	l_3 mm	d_2 $\emptyset h_6$ mm	R467
7/16	11.11	0.4375	55	102	45	12	R4677/16
	11.20	0.4409	55	102	45	12	R46711.2
	11.30	0.4449	55	102	45	12	R46711.3
	11.40	0.4488	55	102	45	12	R46711.4
29/64	11.50	0.4528	55	102	45	12	R46711.5
	11.51	0.4531	55	102	45	12	R46729/64
	11.60	0.4567	55	102	45	12	R46711.6
15/32	11.80	0.4646	55	102	45	12	R46711.8
	11.91	0.4688	55	102	45	12	R46715/32
	12.00	0.4724	55	102	45	12	R46712.0
	12.05	0.4744	60	107	45	14	R46712.05
31/64	12.10	0.4764	60	107	45	14	R46712.1
	12.20	0.4803	60	107	45	14	R46712.2
	12.30	0.4844	60	107	45	14	R46731/64
	12.50	0.4921	60	107	45	14	R46712.5
1/2	12.70	0.5000	60	107	45	14	R46712.7
	12.80	0.5039	60	107	45	14	R4671/2
	12.80	0.5039	60	107	45	14	R46712.8
33/64	13.00	0.5118	60	107	45	14	R46713.0
	13.10	0.5156	60	107	45	14	R46733/64
	13.30	0.5236	60	107	45	14	R46713.3
17/32	13.49	0.5313	60	107	45	14	R46717/32
	13.50	0.5315	60	107	45	14	R46713.5
35/64	13.80	0.5433	60	107	45	14	R46713.8
	13.89	0.5469	60	107	45	14	R46735/64
	14.00	0.5512	60	107	45	14	R46714.0
	14.25	0.5610	65	115	48	16	R46714.25
9/16	14.29	0.5625	65	115	48	16	R4679/16
	14.50	0.5709	65	115	48	16	R46714.5
37/64	14.68	0.5781	65	115	48	16	R46737/64
	14.80	0.5827	65	115	48	16	R46714.8
	15.00	0.5906	65	115	48	16	R46715.0
19/32	15.08	0.5938	65	115	48	16	R46719/32
	15.10	0.5945	65	115	48	16	R46715.1
	15.30	0.6024	65	115	48	16	R46715.3
39/64	15.48	0.6094	65	115	48	16	R46739/64
	15.50	0.6102	65	115	48	16	R46715.5
	15.80	0.6220	65	115	48	16	R46715.8
5/8	15.88	0.6250	65	115	48	16	R4675/8
	16.00	0.6299	65	115	48	16	R46716.0

R463

- Punta Force M con fori di lubrificazione 5×D
- Force M Spiralbohrer, Kühlkanal 5×D
- Force M Spiraalboor met koelkanalen 5×D
- Foret Force M, à trous d'huile 5×D

R463 ■ 2.1 2.2 2.3 2.4 4.1 4.2 4.3
 • 5.1 5.2 5.3

R463

HM

DIN
6537
L

5XD

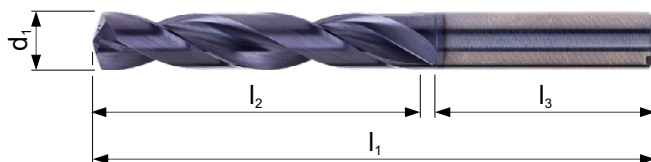

R463



FORCE M
3.00 - 16.00

d ₁ Ø "/Nr./letter	d ₁ Øm ₇ mm	d ₁ decimal Inch	l ₂ mm	l ₁ mm	l ₃ mm	d ₂ Øh ₆ mm	R463
1/8	3.00	0.1181	28	66	36	6	R4633.0
	3.10	0.1220	28	66	36	6	R4633.1
	3.18	0.1250	28	66	36	6	R4631/8
	3.20	0.1260	28	66	36	6	R4633.2
	3.30	0.1299	28	66	36	6	R4633.3
29	3.40	0.1339	28	66	36	6	R4633.4
	3.45	0.1360	28	66	36	6	R463N29
	3.50	0.1378	28	66	36	6	R4633.5
	3.57	0.1406	28	66	36	6	R4639/64
9/64	3.60	0.1417	28	66	36	6	R4633.6
	3.70	0.1457	28	66	36	6	R4633.7
	3.80	0.1496	36	74	36	6	R4633.8
	3.90	0.1535	36	74	36	6	R4633.9
	3.97	0.1563	36	74	36	6	R4635/32
	4.00	0.1575	36	74	36	6	R4634.0
	4.05	0.1594	36	74	36	6	R4634.05
11/64	4.10	0.1614	36	74	36	6	R4634.1
	4.20	0.1654	36	74	36	6	R4634.2
	4.30	0.1693	36	74	36	6	R4634.3
	4.37	0.1719	36	74	36	6	R46311/64
	4.40	0.1732	36	74	36	6	R4634.4
	4.50	0.1772	36	74	36	6	R4634.5
	4.60	0.1811	36	74	36	6	R4634.6
3/16	4.70	0.1850	36	74	36	6	R4634.7
	4.76	0.1875	44	82	36	6	R4633/16
	4.80	0.1890	44	82	36	6	R4634.8
	4.90	0.1929	44	82	36	6	R4634.9
	5.00	0.1969	44	82	36	6	R4635.0
7	5.05	0.1988	44	82	36	6	R4635.05
	5.10	0.2008	44	82	36	6	R4635.1
	5.11	0.2010	44	82	36	6	R463N7
	5.16	0.2031	44	82	36	6	R46313/64
	5.20	0.2047	44	82	36	6	R4635.2
	5.22	0.2055	44	82	36	6	R463N5
5	5.30	0.2087	44	82	36	6	R4635.3
	5.40	0.2126	44	82	36	6	R4635.4
	5.50	0.2165	44	82	36	6	R4635.5
	5.56	0.2188	44	82	36	6	R4637/32

d_1 \emptyset "/Nr./letter	d_1 $\emptyset m_7$ mm	d_1 decimal Inch	l_2 mm	l_1 mm	l_3 mm	d_2 $\emptyset h_6$ mm	R463
	5.60	0.2205	44	82	36	6	R4635.6
	5.70	0.2244	44	82	36	6	R4635.7
	5.80	0.2283	44	82	36	6	R4635.8
	5.90	0.2323	44	82	36	6	R4635.9
15/64	5.95	0.2344	44	82	36	6	R46315/64
	6.00	0.2362	44	82	36	6	R4636.0
	6.05	0.2382	53	91	36	8	R4636.05
	6.10	0.2402	53	91	36	8	R4636.1
	6.20	0.2441	53	91	36	8	R4636.2
	6.30	0.2480	53	91	36	8	R4636.3
1/4	6.35	0.2500	53	91	36	8	R4631/4
	6.40	0.2520	53	91	36	8	R4636.4
	6.50	0.2559	53	91	36	8	R4636.5
	6.60	0.2598	53	91	36	8	R4636.6
	6.70	0.2638	53	91	36	8	R4636.7
17/64	6.75	0.2656	53	91	36	8	R46317/64
	6.80	0.2677	53	91	36	8	R4636.8
	6.90	0.2717	53	91	36	8	R4636.9
	7.00	0.2756	53	91	36	8	R4637.0
	7.10	0.2795	53	91	36	8	R4637.1
9/32	7.14	0.2813	53	91	36	8	R4639/32
	7.20	0.2835	53	91	36	8	R4637.2
	7.30	0.2874	53	91	36	8	R4637.3
	7.40	0.2913	53	91	36	8	R4637.4
	7.50	0.2953	53	91	36	8	R4637.5
19/64	7.54	0.2969	53	91	36	8	R46319/64
	7.60	0.2992	53	91	36	8	R4637.6
	7.70	0.3031	53	91	36	8	R4637.7
	7.80	0.3071	53	91	36	8	R4637.8
	7.90	0.3110	53	91	36	8	R4637.9
5/16	7.94	0.3125	53	91	36	8	R4635/16
	8.00	0.3150	53	91	36	8	R4638.0
	8.05	0.3169	61	103	40	10	R4638.05
	8.10	0.3189	61	103	40	10	R4638.1
	8.20	0.3228	61	103	40	10	R4638.2
	8.30	0.3268	61	103	40	10	R4638.3
21/64	8.33	0.3281	61	103	40	10	R46321/64
	8.40	0.3307	61	103	40	10	R4638.4
	8.50	0.3346	61	103	40	10	R4638.5
	8.60	0.3386	61	103	40	10	R4638.6
	8.70	0.3425	61	103	40	10	R4638.7
11/32	8.73	0.3438	61	103	40	10	R46311/32
	8.80	0.3465	61	103	40	10	R4638.8
	8.90	0.3504	61	103	40	10	R4638.9
	9.00	0.3543	61	103	40	10	R4639.0
	9.10	0.3583	61	103	40	10	R4639.1
23/64	9.13	0.3594	61	103	40	10	R46323/64
	9.20	0.3622	61	103	40	10	R4639.2
	9.30	0.3661	61	103	40	10	R4639.3
	9.40	0.3701	61	103	40	10	R4639.4
	9.50	0.3740	61	103	40	10	R4639.5
3/8	9.53	0.3750	61	103	40	10	R4633/8
	9.60	0.3780	61	103	40	10	R4639.6
	9.70	0.3819	61	103	40	10	R4639.7
	9.80	0.3858	61	103	40	10	R4639.8
	9.90	0.3898	61	103	40	10	R4639.9
25/64	9.92	0.3906	61	103	40	10	R46325/64
	10.00	0.3937	61	103	40	10	R46310.0
	10.05	0.3957	70	118	45	12	R46310.05
	10.10	0.3976	70	118	45	12	R46310.1
	10.20	0.4016	70	118	45	12	R46310.2
	10.30	0.4055	70	118	45	12	R46310.3
13/32	10.32	0.4063	70	118	45	12	R46313/32
	10.40	0.4094	70	118	45	12	R46310.4
	10.50	0.4134	70	118	45	12	R46310.5
	10.60	0.4173	70	118	45	12	R46310.6
27/64	10.72	0.4219	70	118	45	12	R46327/64
	10.80	0.4252	70	118	45	12	R46310.8
	10.90	0.4291	70	118	45	12	R46310.9
	11.00	0.4331	70	118	45	12	R46311.0

d_1 Ø "/Nr./letter	d_1 Ø m_7 mm	d_1 decimal Inch	l_2 mm	l_1 mm	l_3 mm	d_2 Ø h_6 mm	R463
7/16	11.11	0.4375	70	118	45	12	R4637/16
	11.20	0.4409	70	118	45	12	R46311.2
	11.30	0.4449	70	118	45	12	R46311.3
	11.40	0.4488	70	118	45	12	R46311.4
	11.50	0.4528	70	118	45	12	R46311.5
29/64	11.51	0.4531	70	118	45	12	R46329/64
	11.60	0.4567	70	118	45	12	R46311.6
	11.80	0.4646	70	118	45	12	R46311.8
15/32	11.91	0.4688	70	118	45	12	R46315/32
	12.00	0.4724	70	118	45	12	R46312.0
	12.05	0.4744	76	124	45	14	R46312.05
31/64	12.20	0.4803	76	124	45	14	R46312.2
	12.30	0.4844	76	124	45	14	R46331/64
	12.50	0.4921	76	124	45	14	R46312.5
	12.70	0.5000	76	124	45	14	R46312.7
1/2	12.70	0.5000	76	124	45	14	R4631/2
	12.80	0.5039	76	124	45	14	R46312.8
	13.00	0.5118	76	124	45	14	R46313.0
33/64	13.10	0.5156	76	124	45	14	R46333/64
	13.30	0.5236	76	124	45	14	R46313.3
17/32	13.49	0.5313	76	124	45	14	R46317/32
	13.50	0.5315	76	124	45	14	R46313.5
	13.80	0.5433	76	124	45	14	R46313.8
35/64	13.89	0.5469	76	124	45	14	R46335/64
	14.00	0.5512	76	124	45	14	R46314.0
	14.25	0.5610	82	133	48	16	R46314.25
9/16	14.29	0.5625	82	133	48	16	R4639/16
	14.50	0.5709	82	133	48	16	R46314.5
37/64	14.68	0.5781	82	133	48	16	R46337/64
	14.80	0.5827	82	133	48	16	R46314.8
	15.00	0.5906	82	133	48	16	R46315.0
19/32	15.08	0.5938	82	133	48	16	R46319/32
	15.10	0.5945	82	133	48	16	R46315.1
	15.30	0.6024	82	133	48	16	R46315.3
39/64	15.48	0.6094	82	133	48	16	R46339/64
	15.50	0.6102	82	133	48	16	R46315.5
	15.80	0.6220	82	133	48	16	R46315.8
	15.88	0.6250	82	133	48	16	R4635/8
5/8	16.00	0.6299	82	133	48	16	R46316.0

A723

- Punta per cordoni di saldatura
- Schweißpunktbohrer
- Puntlasboor
- Forets pour points de soudure

A723 ■ 1.1 1.2
 • 1.3 1.4

A723 HSS-E DORMER 1XD Bronze N

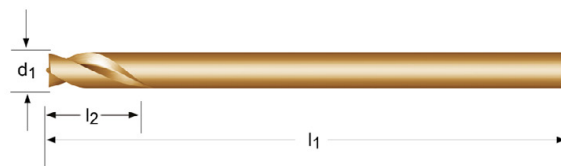

d_1 \varnothing_{h_8} mm	d_1 decimal inch	l_2 mm	l_1 mm	A723
6.00	0.2362	18	66	A7236.0X66
6.00	0.2362	18	93	A7236.0X93
8.00	0.3150	24	79	A7238.0X79
8.00	0.3150	24	117	A7238.0X117

A122

- Punta da centro
- NC-Anbohrer
- NC-centerboor
- Foret à pointer

Lunghezza totale secondo DIN 1897
Gesamtlänge nach DIN 1897
Totale lengte vlg. DIN 1897
Longueur totale selon la DIN 1897

A122	▪	1.1	1.2	1.3	6.1	6.2	6.3	6.4	7.1	7.2												
	•	1.4	1.5	1.6	2.1	2.2	2.3	3.1	3.2	3.3	3.4	4.1	4.2	4.3	5.1	5.2	5.3	7.3	7.4	8.1	8.2	
		8.3	9.1																			

A122 HSS DIN 1897 1XD 90°/120° N

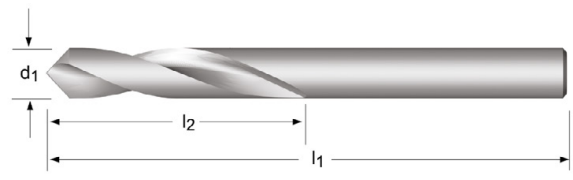

d_1 \varnothing_{h_8} mm	d_1 decimal Inch	l_2 mm	l_1 mm	A122
6.00	0.2362	30	66	A1226.0X90
6.00	0.2362	30	66	A1226.0X120
8.00	0.3150	33	79	A1228.0X90
8.00	0.3150	33	79	A1228.0X120
10.00	0.3937	35	89	A12210.0X90
10.00	0.3937	35	89	A12210.0X120
12.00	0.4724	40	102	A12212.0X90
12.00	0.4724	40	102	A12212.0X120
16.00	0.6299	40	115	A12216.0X90
16.00	0.6299	40	115	A12216.0X120
20.00	0.7874	55	131	A12220.0X90
20.00	0.7874	55	131	A12220.0X120

A119

- Punta extra corta - doppia estremità
- Spiralbohrer, kurz, 2-seitig
- Extra korte spiraalboor - dubbelzijdig
- Foret extra-court - Double

Punta per lamiera
Blechbohrer
Plaatboor
Forets pour tôle

A119	▪	1.1	1.2																		
	•	1.3	1.4	1.5	1.6	2.1	2.2	2.3	4.1	4.2	4.3	5.1	5.2	5.3	6.1	6.2	6.3	6.4	7.1	7.2	7.3
		7.4	8.1	8.2																	

A119 HSS DIN 1897 1.25XD 120° ST N

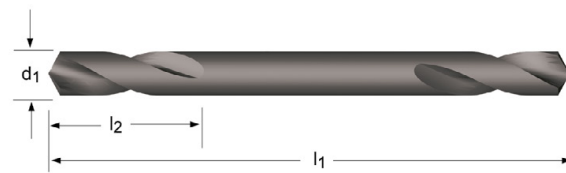

d_1 $\varnothing h_8$ mm	d_1 decimal Inch	l_2 mm	l_1 mm	A119
3.30	0.1299	11	49	A1193.3
3.60	0.1417	12	52	A1193.6
4.10	0.1614	14	55	A1194.1
4.20	0.1654	14	55	A1194.2
4.90	0.1929	17	62	A1194.9
5.10	0.2008	17	62	A1195.1

A123

- Punta serie extra-corta
- Spiralbohrer, kurz
- Extra korte spiraalboor
- Foret extra-court

Lunghezza complessiva secondo DIN 1897 e punta per lamiera
Gesamtlänge nach DIN 1897 und Blechbohrer
Plaatwerkboor met totale lengte conform DIN 1897
Foret pour tôle. Longueur hors-tout selon DIN 1897

A123	▪	1.1	1.2	1.3	6.1	6.2	6.3	6.4	7.1	7.2									
	•	1.4	1.5	1.6	2.1	2.2	2.3	4.1	4.2	4.3	5.1	5.2	5.3	7.3	7.4	8.1	8.2	8.3	9.1

A123

HSS

DIN
1897

1.5XD



N

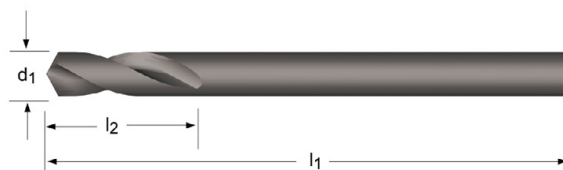

A123



3/32 - 1/4

d_1 \varnothing_{h_8} Inch	d_1 \varnothing_{h_8} mm	d_1 decimal Inch	l_2 mm	l_1 mm	A123
3/32	2.38	0.0937	14	43	A1233/32S
	2.50	0.0984	14	43	A1232.5S
	3.00	0.1181	16	46	A1233.0S
1/8	3.18	0.1252	18	49	A1231/8S
	3.20	0.1260	18	49	A1233.2S
	3.30	0.1299	18	49	A1233.3S
	3.50	0.1378	18	52	A1233.5S
	3.70	0.1457	18	52	A1233.7S
5/32	3.97	0.1563	18	55	A1235/32S
	4.00	0.1575	18	55	A1234.0S
	4.10	0.1614	18	55	A1234.1S
	4.20	0.1654	18	55	A1234.2S
	4.50	0.1772	18	58	A1234.5S
3/16	4.76	0.1874	18	62	A1233/16S
	4.80	0.1890	18	62	A1234.8S
	4.90	0.1929	18	62	A1234.9S
	5.00	0.1969	18	62	A1235.0S
	5.50	0.2165	18	66	A1235.5S
7/32	5.56	0.2189	18	66	A1237/32S
	6.00	0.2362	18	66	A1236.0S
1/4	6.35	0.2500	19	70	A1231/4S

A120

- Punta serie extra-corta
- Spiralbohrer, kurz
- Extra korte spiraalboor
- Foret extra-court

Senza trattamento sotto 1,0 mm. 118° fino a 2,9 mm e oltre 13,0 mm
 Blank bis 1 mm Ø, 118° Kegelmantelschliff bis 2,9 mm Ø und über 13,0 mm Ø
 Blank beneden 1,0mm. 118° punt tot 2,9mm en boven 13,0mm
 Brillant au dessous de 1,0 mm. Pointe à 118° jusqu'au Ø 2,9 mm et au dessus du Ø 13,0 mm

A022

- 022 Punta serie extra-corta
- 022 Spiralbohrer, kurz
- 022 Extra korte spiraalboor
- 022 Foret extra-court

Lucida sotto i 2mm, con rivestimento parziale TiN e affilatura split point da 2mm in su
 Blank bis 2.0 mm, TiN-tip beschichtet mit Kreuzanschliff ab 2,0 mm
 Blank tot 2.0 mm, TiN-Tip gecoat met kruisslijping vanaf 2.0 mm
 Brillant en dessous de 2,0mm, TiN en pointe et affutage en croix au dessus de 2,0 mm

A620

- Punta serie extra-corta
- Spiralbohrer, kurz
- Extra korte spiraalboor
- Foret extra-court

A117

- Punta serie extra-corta
- Spiralbohrer, kurz
- Extra korte spiraalboor
- Foret extra-court

118° fino a 1,5 mm
 Kegelmantelschliff 118° bis 1,5 mm Ø
 118° punt tot 1,5 mm
 Pointe à 118° jusqu'au Ø 1,5 mm

A120	▪	1.1	1.2	1.3	1.4	2.1	3.1	3.2	3.3	4.1																	
	•	1.5	1.6	2.2	2.3	3.4	4.2	4.3	5.1	5.2	5.3	6.1	6.2	6.3	6.4	7.1	7.2	7.3	7.4	8.1	8.2	8.3	9.1				
A022	▪	1.1	1.2	1.3	1.4	1.5	2.1	3.1	3.2	3.3	4.1	7.1	7.2	7.3													
	•	1.6	2.2	2.3	3.4	4.2	4.3	5.1	5.2	5.3	6.1	6.2	6.3	6.4	7.4	8.1	8.2	8.3	9.1								
A620	▪	2.1	2.2	2.3																							
	•	1.1	1.2	1.3	1.4	1.5	1.6	3.1	3.2	3.3	3.4	4.1	4.2	4.3	5.1	5.2	5.3	6.1	6.2	6.3	6.4	7.1	7.2	7.3	7.4	8.1	8.2
A117	▪	1.5	1.6	2.1	2.2	2.3	3.4	4.1	4.2	4.3	5.1	5.2	5.3	9.1													
	•	1.1	1.2	1.3	1.4	3.1	3.2	3.3	6.1	6.2	6.3	6.4	7.1	7.2	7.3	7.4	8.1	8.2	8.3								

A120	HSS	DIN 1897	2.5XD	135°	ST		N			
A022	HSS	DIN ANSI	2.5XD	135°	TiN		N			
A620	HSS-E	DIN 1897	2.5XD	130°	Bronze		N			
A117	HSS-E	DIN 1897	2.5XD	135°	Bronze		N			

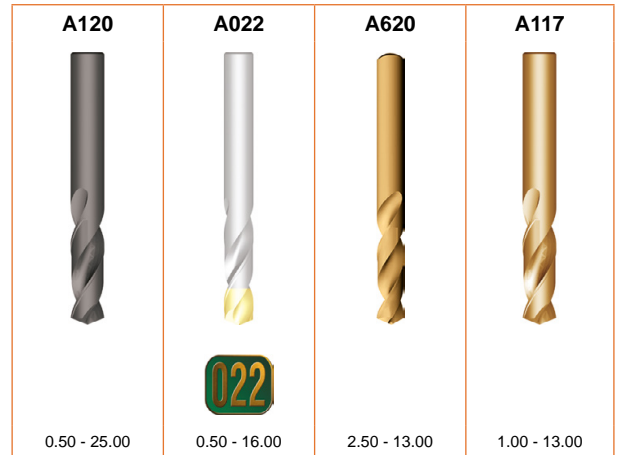
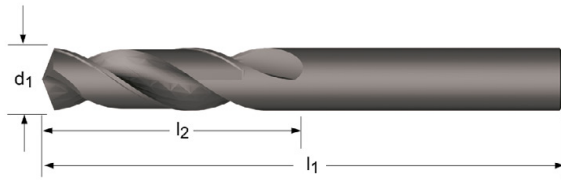

d_1 $\varnothing h_8$ Inch	d_1 $\varnothing h_8$ mm	d_1 decimal Inch	l_2 mm	l_1 mm	A120	A022	A620	A117
	0.50	0.0197	3	20	A120.5	A022.5		
	0.60	0.0236	3.5	21	A120.6	A022.6		
	0.70	0.0276	4.5	23	A120.7	A022.7		
1/32	0.79	0.0311	13	35		A0221/32		
1/32	0.79	0.0311	5	24	A1201/32			
	0.80	0.0315	5	24	A120.8	A022.8		
	0.90	0.0354	5.5	25	A120.9	A022.9		
	1.00	0.0394	6	26	A1201.0	A0221.0		A1171.0
	1.10	0.0433	7	28	A1201.1	A0221.1		A1171.1
3/64	1.19	0.0469	13	35		A0223/64		
3/64	1.19	0.0469	8	30	A1203/64			
	1.20	0.0472	8	30	A1201.2	A0221.2		A1171.2
	1.30	0.0512	8	30	A1201.3	A0221.3		A1171.3
	1.40	0.0551	9	32	A1201.4	A0221.4		A1171.4
	1.50	0.0591	9	32	A1201.5	A0221.5		A1171.5
1/16	1.59	0.0626	10	34	A1201/16			
1/16	1.59	0.0626	16	41		A0221/16		
	1.60	0.0630	10	34	A1201.6	A0221.6		A1171.6
	1.70	0.0669	10	34	A1201.7	A0221.7		A1171.7
	1.80	0.0709	11	36	A1201.8	A0221.8		A1171.8
	1.90	0.0748	11	36	A1201.9	A0221.9		A1171.9
5/64	1.98	0.0780	12	38	A1205/64			
5/64	1.98	0.0780	17	43		A0225/64		
	2.00	0.0787	12	38	A1202.0	A0222.0		A1172.0
	2.10	0.0827	12	38	A1202.1	A0222.1		A1172.1
	2.20	0.0866	13	40	A1202.2	A0222.2		A1172.2
	2.25	0.0886	13	40	A1202.25	A0222.25		
	2.30	0.0906	13	40	A1202.3	A0222.3		A1172.3
3/32	2.38	0.0937	14	43	A1203/32			
3/32	2.38	0.0937	20	45		A0223/32		
	2.40	0.0945	14	43	A1202.4	A0222.4		A1172.4
	2.50	0.0984	14	43	A1202.5	A0222.5	A6202.5	A1172.5
	2.60	0.1024	14	43	A1202.6	A0222.6	A6202.6	A1172.6
	2.65	0.1043	14	43	A1202.65	A0222.65		
	2.70	0.1063	16	46	A1202.7	A0222.7	A6202.7	A1172.7
7/64	2.78	0.1094	16	46	A1207/64			
7/64	2.78	0.1094	22	47		A0227/64		
	2.80	0.1102	16	46	A1202.8	A0222.8	A6202.8	A1172.8
	2.90	0.1142	16	46	A1202.9	A0222.9	A6202.9	A1172.9
	3.00	0.1181	16	46	A1203.0	A0223.0	A6203.0	A1173.0
	3.10	0.1220	18	49	A1203.1	A0223.1	A6203.1	A1173.1
1/8	3.18	0.1252	18	49	A1201/8			A1171/8
1/8	3.18	0.1252	23	49		A0221/8		
	3.20	0.1260	18	49	A1203.2	A0223.2	A6203.2	A1173.2
	3.25	0.1280	18	49	A1203.25	A0223.25		
	3.30	0.1299	18	49	A1203.3	A0223.3	A6203.3	A1173.3
	3.40	0.1339	20	52	A1203.4	A0223.4	A6203.4	A1173.4
	3.50	0.1378	20	52	A1203.5	A0223.5	A6203.5	A1173.5
9/64	3.57	0.1406	20	52	A1209/64			
9/64	3.57	0.1406	25	50		A0229/64		
	3.60	0.1417	20	52	A1203.6	A0223.6	A6203.6	A1173.6
	3.70	0.1457	20	52	A1203.7	A0223.7	A6203.7	A1173.7
	3.80	0.1496	22	55	A1203.8	A0223.8	A6203.8	A1173.8
	3.90	0.1535	22	55	A1203.9	A0223.9	A6203.9	A1173.9

d_1 \varnothing_{h_8} Inch	d_1 \varnothing_{h_8} mm	d_1 decimal Inch	l_2 mm	l_1 mm	A120	A022	A620	A117
5/32	3.97	0.1563	22	55	A1205/32			A1175/32
5/32	3.97	0.1563	26	53		A0225/32		
	4.00	0.1575	22	55	A1204.0	A0224.0	A6204.0	A1174.0
	4.10	0.1614	22	55	A1204.1	A0224.1	A6204.1	A1174.1
	4.20	0.1654	22	55	A1204.2	A0224.2	A6204.2	A1174.2
	4.30	0.1693	24	58	A1204.3	A0224.3	A6204.3	A1174.3
11/64	4.37	0.1720	24	58	A12011/64			
11/64	4.37	0.1720	28	55		A02211/64		
	4.40	0.1732	24	58	A1204.4	A0224.4	A6204.4	A1174.4
	4.50	0.1772	24	58	A1204.5	A0224.5	A6204.5	A1174.5
	4.60	0.1811	24	58	A1204.6	A0224.6	A6204.6	A1174.6
	4.70	0.1850	24	58	A1204.7	A0224.7	A6204.7	A1174.7
3/16	4.76	0.1874	26	62	A1203/16			A1173/16
3/16	4.76	0.1874	30	57		A0223/16		
	4.80	0.1890	26	62	A1204.8	A0224.8	A6204.8	A1174.8
	4.90	0.1929	26	62	A1204.9	A0224.9	A6204.9	A1174.9
	5.00	0.1969	26	62	A1205.0	A0225.0	A6205.0	A1175.0
	5.10	0.2008	26	62	A1205.1	A0225.1	A6205.1	A1175.1
13/64	5.16	0.2031	26	62	A12013/64			
13/64	5.16	0.2031	31	58		A02213/64		
	5.20	0.2047	26	62	A1205.2	A0225.2	A6205.2	A1175.2
	5.30	0.2087	26	62	A1205.3	A0225.3	A6205.3	A1175.3
	5.40	0.2126	28	66	A1205.4	A0225.4	A6205.4	A1175.4
	5.50	0.2165	28	66	A1205.5	A0225.5	A6205.5	A1175.5
7/32	5.56	0.2189	28	66	A1207/32			
7/32	5.56	0.2189	33	61		A0227/32		
	5.60	0.2205	28	66	A1205.6	A0225.6	A6205.6	A1175.6
	5.70	0.2244	28	66	A1205.7	A0225.7	A6205.7	A1175.7
	5.80	0.2283	28	66	A1205.8	A0225.8	A6205.8	A1175.8
	5.90	0.2323	28	66	A1205.9	A0225.9	A6205.9	A1175.9
15/64	5.95	0.2343	28	66	A12015/64			
15/64	5.95	0.2343	34	63		A02215/64		
	6.00	0.2362	28	66	A1206.0	A0226.0	A6206.0	A1176.0
	6.10	0.2402	31	70	A1206.1	A0226.1	A6206.1	A1176.1
	6.20	0.2441	31	70	A1206.2	A0226.2	A6206.2	A1176.2
	6.30	0.2480	31	70	A1206.3	A0226.3	A6206.3	A1176.3
1/4	6.35	0.2500	31	70	A1201/4			A1171/4
1/4	6.35	0.2500	36	65		A0221/4		
	6.40	0.2520	31	70	A1206.4	A0226.4	A6206.4	A1176.4
	6.50	0.2559	31	70	A1206.5	A0226.5	A6206.5	A1176.5
	6.60	0.2598	31	70	A1206.6	A0226.6	A6206.6	A1176.6
	6.70	0.2638	31	70	A1206.7	A0226.7	A6206.7	A1176.7
	6.80	0.2677	34	74	A1206.8	A0226.8	A6206.8	A1176.8
	6.90	0.2717	34	74	A1206.9	A0226.9	A6206.9	A1176.9
	7.00	0.2756	34	74	A1207.0	A0227.0	A6207.0	A1177.0
	7.10	0.2795	34	74	A1207.1	A0227.1	A6207.1	A1177.1
9/32	7.14	0.2811	34	74	A1209/32			
9/32	7.14	0.2811	40	70		A0229/32		
	7.20	0.2835	34	74	A1207.2	A0227.2	A6207.2	A1177.2
	7.30	0.2874	34	74	A1207.3	A0227.3	A6207.3	A1177.3
	7.40	0.2913	34	74	A1207.4	A0227.4	A6207.4	A1177.4
	7.50	0.2953	34	74	A1207.5	A0227.5	A6207.5	A1177.5
	7.60	0.2992	37	79	A1207.6	A0227.6	A6207.6	A1177.6
	7.70	0.3031	37	79	A1207.7	A0227.7	A6207.7	A1177.7
	7.80	0.3071	37	79	A1207.8	A0227.8	A6207.8	A1177.8
	7.90	0.3110	37	79	A1207.9	A0227.9	A6207.9	A1177.9
5/16	7.94	0.3126	37	79	A1205/16			A1175/16
5/16	7.94	0.3126	43	73		A0225/16		
	8.00	0.3150	37	79	A1208.0	A0228.0	A6208.0	A1178.0
	8.10	0.3189	37	79	A1208.1	A0228.1	A6208.1	A1178.1
	8.20	0.3228	37	79	A1208.2	A0228.2	A6208.2	A1178.2
	8.30	0.3268	37	79	A1208.3	A0228.3	A6208.3	A1178.3
	8.40	0.3307	37	79	A1208.4	A0228.4	A6208.4	A1178.4
	8.50	0.3346	37	79	A1208.5	A0228.5	A6208.5	A1178.5
	8.60	0.3386	40	84	A1208.6	A0228.6	A6208.6	A1178.6
	8.70	0.3425	40	84	A1208.7	A0228.7	A6208.7	A1178.7
11/32	8.73	0.3437	40	84	A12011/32			
11/32	8.73	0.3437	45	78		A02211/32		
	8.80	0.3465	40	84	A1208.8	A0228.8	A6208.8	A1178.8
	8.90	0.3504	40	84	A1208.9	A0228.9	A6208.9	A1178.9
	9.00	0.3543	40	84	A1209.0	A0229.0	A6209.0	A1179.0
	9.10	0.3583	40	84	A1209.1	A0229.1	A6209.1	A1179.1

d_1 $\varnothing h_8$ Inch	d_1 $\varnothing h_8$ mm	d_1 decimal Inch	l_2 mm	l_1 mm	A120	A022	A620	A117
	9.20	0.3622	40	84	A1209.2	A0229.2	A6209.2	A1179.2
	9.30	0.3661	40	84	A1209.3	A0229.3	A6209.3	A1179.3
	9.40	0.3701	40	84	A1209.4	A0229.4	A6209.4	A1179.4
	9.50	0.3740	40	84	A1209.5	A0229.5	A6209.5	A1179.5
3/8	9.52	0.3748	43	89	A1203/8			A1173/8
3/8	9.52	0.3748	48	81		A0223/8		
	9.60	0.3780	43	89	A1209.6	A0229.6	A6209.6	A1179.6
	9.70	0.3819	43	89	A1209.7	A0229.7	A6209.7	A1179.7
	9.80	0.3858	43	89	A1209.8	A0229.8	A6209.8	A1179.8
	9.90	0.3898	43	89	A1209.9	A0229.9	A6209.9	A1179.9
	10.00	0.3937	43	89	A12010.0	A02210.0	A62010.0	A11710.0
	10.10	0.3976	43	89	A12010.1	A02210.1		
	10.20	0.4016	43	89	A12010.2	A02210.2	A62010.2	A11710.2
	10.30	0.4055	43	89	A12010.3	A02210.3	A62010.3	
13/32	10.32	0.4063	43	89	A12013/32			
13/32	10.32	0.4063	51	86		A02213/32		
	10.40	0.4094	43	89	A12010.4	A02210.4	A62010.4	
	10.50	0.4134	43	89	A12010.5	A02210.5	A62010.5	A11710.5
	10.60	0.4173	43	89	A12010.6	A02210.6		
	10.70	0.4213	47	95	A12010.7	A02210.7		
	10.80	0.4252	47	95	A12010.8	A02210.8	A62010.8	
	10.90	0.4291	47	95	A12010.9	A02210.9		
	11.00	0.4331	47	95	A12011.0	A02211.0	A62011.0	A11711.0
	11.10	0.4370	47	95	A12011.1	A02211.1		
7/16	11.11	0.4374	47	95	A1207/16			
7/16	11.11	0.4374	54	89		A0227/16		
	11.20	0.4409	47	95	A12011.2	A02211.2		
	11.30	0.4449	47	95	A12011.3	A02211.3		
	11.50	0.4528	47	95	A12011.5	A02211.5	A62011.5	A11711.5
	11.60	0.4567	47	95	A12011.6	A02211.6		
	11.70	0.4606	47	95	A12011.7	A02211.7		
	11.80	0.4646	47	95	A12011.8	A02211.8		
	11.90	0.4685	51	102	A12011.9	A02211.9		
	12.00	0.4724	51	102	A12012.0	A02212.0	A62012.0	A11712.0
	12.10	0.4764	51	102	A12012.1	A02212.1		
	12.20	0.4803	51	102	A12012.2	A02212.2	A62012.2	
	12.50	0.4921	51	102	A12012.5	A02212.5	A62012.5	
1/2	12.70	0.5000	51	102	A1201/2			A1171/2
1/2	12.70	0.5000	60	98		A0221/2		
	12.80	0.5039	51	102			A62012.8	
	13.00	0.5118	51	102	A12013.0	A02213.0	A62013.0	A11713.0
	13.50	0.5315	54	107	A12013.5	A02213.5		
	14.00	0.5512	54	107	A12014.0	A02214.0		
9/16	14.29	0.5626	56	111	A1209/16			
9/16	14.29	0.5626	67	105		A0229/16		
	14.50	0.5709	56	111	A12014.5	A02214.5		
	15.00	0.5906	56	111	A12015.0	A02215.0		
	15.50	0.6102	58	115	A12015.5	A02215.5		
5/8	15.88	0.6252	58	115	A1205/8			
5/8	15.88	0.6252	73	111		A0225/8		
	16.00	0.6299	58	115	A12016.0	A02216.0		
	16.50	0.6496	60	119	A12016.5			
	17.00	0.6693	60	119	A12017.0			
11/16	17.46	0.6874	62	123	A12011/16			
	17.50	0.6890	62	123	A12017.5			
	18.00	0.7087	62	123	A12018.0			
	18.50	0.7283	64	127	A12018.5			
	19.00	0.7480	64	127	A12019.0			
3/4	19.05	0.7500	66	131	A1203/4			
	19.50	0.7677	66	131	A12019.5			
	20.00	0.7874	66	131	A12020.0			
	20.50	0.8071	68	136	A12020.5			
13/16	20.64	0.8126	68	136	A12013/16			
	21.00	0.8268	68	136	A12021.0			
	22.00	0.8661	70	141	A12022.0			
7/8	22.22	0.8748	70	141	A1207/8			
	23.00	0.9055	72	146	A12023.0			
15/16	23.81	0.9374	75	151	A12015/16			
	24.00	0.9449	75	151	A12024.0			
	25.00	0.9843	75	151	A12025.0			

A520

- Punta ADX serie extra corta
- ADX Spiralbohrer, kurz
- ADX spiraalboor, extra kort
- Foret extra-court ADX

A520	▪	1.1	1.2	1.3	1.4	1.5	2.1	2.2	2.3	3.1	3.2	3.3	3.4	4.1	4.2	6.2	6.3	7.2	7.3	7.4	8.2	
		8.3																				
	•	1.6	4.3	5.1	5.2	5.3	6.1	6.4	7.1	8.1												

A520 **HSS** **DIN 1897** **2.5XD** **130°** **TiN**

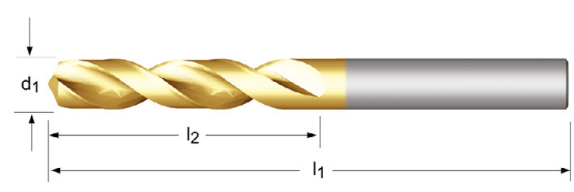

d_1 $\varnothing h_8$ Inch	d_1 $\varnothing h_8$ mm	d_1 decimal Inch	l_2 mm	l_1 mm	A520
	3.00	0.1181	16	46	A5203.0
	3.10	0.1220	18	49	A5203.1
1/8	3.18	0.1252	18	49	A5201/8
	3.20	0.1260	18	49	A5203.2
	3.30	0.1299	18	49	A5203.3
	3.40	0.1339	20	52	A5203.4
	3.50	0.1378	20	52	A5203.5
9/64	3.57	0.1406	20	52	A5209/64
	3.60	0.1417	20	52	A5203.6
	3.70	0.1457	20	52	A5203.7
	3.80	0.1496	22	55	A5203.8
	3.90	0.1535	22	55	A5203.9
5/32	3.97	0.1563	22	55	A5205/32
	4.00	0.1575	22	55	A5204.0
	4.10	0.1614	22	55	A5204.1
	4.20	0.1654	22	55	A5204.2
	4.30	0.1693	24	58	A5204.3
11/64	4.37	0.1720	24	58	A52011/64
	4.40	0.1732	24	58	A5204.4
	4.50	0.1772	24	58	A5204.5
	4.60	0.1811	24	58	A5204.6
	4.70	0.1850	24	58	A5204.7
3/16	4.76	0.1874	26	62	A5203/16
	4.80	0.1890	26	62	A5204.8
	4.90	0.1929	26	62	A5204.9
	5.00	0.1969	26	62	A5205.0
	5.10	0.2008	26	62	A5205.1
13/64	5.16	0.2031	26	62	A52013/64
	5.20	0.2047	26	62	A5205.2
	5.30	0.2087	26	62	A5205.3
	5.40	0.2126	28	66	A5205.4
	5.50	0.2165	28	66	A5205.5
7/32	5.56	0.2189	28	66	A5207/32
	5.60	0.2205	28	66	A5205.6
	5.70	0.2244	28	66	A5205.7
	5.80	0.2283	28	66	A5205.8
	5.90	0.2323	28	66	A5205.9
15/64	5.95	0.2343	28	66	A52015/64

d_1 $\varnothing h_8$ Inch	d_1 $\varnothing h_8$ mm	d_1 decimal Inch	l_2 mm	l_1 mm	A520
	6.00	0.2362	28	66	A5206.0
	6.10	0.2402	31	70	A5206.1
	6.20	0.2441	31	70	A5206.2
	6.30	0.2480	31	70	A5206.3
1/4	6.35	0.2500	31	70	A5201/4
	6.40	0.2520	31	70	A5206.4
	6.50	0.2559	31	70	A5206.5
	6.60	0.2598	31	70	A5206.6
	6.70	0.2638	31	70	A5206.7
17/64	6.75	0.2657	34	74	A52017/64
	6.80	0.2677	34	74	A5206.8
	6.90	0.2717	34	74	A5206.9
	7.00	0.2756	34	74	A5207.0
	7.10	0.2795	34	74	A5207.1
9/32	7.14	0.2811	34	74	A5209/32
	7.20	0.2835	34	74	A5207.2
	7.30	0.2874	34	74	A5207.3
	7.40	0.2913	34	74	A5207.4
	7.50	0.2953	34	74	A5207.5
19/64	7.54	0.2969	37	79	A52019/64
	7.60	0.2992	37	79	A5207.6
	7.70	0.3031	37	79	A5207.7
	7.80	0.3071	37	79	A5207.8
	7.90	0.3110	37	79	A5207.9
5/16	7.94	0.3126	37	79	A5205/16
	8.00	0.3150	37	79	A5208.0
	8.10	0.3189	37	79	A5208.1
	8.20	0.3228	37	79	A5208.2
	8.30	0.3268	37	79	A5208.3
21/64	8.33	0.3280	37	79	A52021/64
	8.40	0.3307	37	79	A5208.4
	8.50	0.3346	37	79	A5208.5
	8.60	0.3386	40	84	A5208.6
	8.70	0.3425	40	84	A5208.7
11/32	8.73	0.3437	40	84	A52011/32
	8.80	0.3465	40	84	A5208.8
	8.90	0.3504	40	84	A5208.9
	9.00	0.3543	40	84	A5209.0
	9.10	0.3583	40	84	A5209.1
23/64	9.13	0.3594	40	84	A52023/64
	9.20	0.3622	40	84	A5209.2
	9.30	0.3661	40	84	A5209.3
	9.40	0.3701	40	84	A5209.4
	9.50	0.3740	40	84	A5209.5
3/8	9.52	0.3748	43	89	A5203/8
	9.60	0.3780	43	89	A5209.6
	9.70	0.3819	43	89	A5209.7
	9.80	0.3858	43	89	A5209.8
	9.90	0.3898	43	89	A5209.9
25/64	9.92	0.3906	43	89	A52025/64
	10.00	0.3937	43	89	A52010.0
	10.10	0.3976	43	89	A52010.1
	10.20	0.4016	43	89	A52010.2
	10.30	0.4055	43	89	A52010.3
13/32	10.32	0.4063	43	89	A52013/32
	10.40	0.4094	43	89	A52010.4
	10.50	0.4134	43	89	A52010.5
	10.60	0.4173	43	89	A52010.6
	10.70	0.4213	47	95	A52010.7
27/64	10.72	0.4220	47	95	A52027/64
	10.80	0.4252	47	95	A52010.8
	10.90	0.4291	47	95	A52010.9
	11.00	0.4331	47	95	A52011.0
	11.10	0.4370	47	95	A52011.1
7/16	11.11	0.4374	47	95	A5207/16
	11.20	0.4409	47	95	A52011.2
	11.30	0.4449	47	95	A52011.3
	11.40	0.4488	47	95	A52011.4
	11.50	0.4528	47	95	A52011.5
29/64	11.51	0.4531	47	95	A52029/64

d_1 $\varnothing h_8$ Inch	d_1 $\varnothing h_8$ mm	d_1 decimal Inch	l_2 mm	l_1 mm	A520
	11.60	0.4567	47	95	A52011.6
	11.70	0.4606	47	95	A52011.7
	11.80	0.4646	47	95	A52011.8
	11.90	0.4685	51	102	A52011.9
15/32	11.91	0.4689	51	102	A52015/32
	12.00	0.4724	51	102	A52012.0
	12.10	0.4764	51	102	A52012.1
	12.20	0.4803	51	102	A52012.2
	12.30	0.4843	51	102	A52012.3
31/64	12.30	0.4843	51	102	A52031/64
	12.40	0.4882	51	102	A52012.4
	12.50	0.4921	51	102	A52012.5
	12.60	0.4961	51	102	A52012.6
	12.70	0.5000	51	102	A52012.7
1/2	12.70	0.5000	51	102	A5201/2
	12.80	0.5039	51	102	A52012.8
	12.90	0.5079	51	102	A52012.9
	13.00	0.5118	51	102	A52013.0

A124

- Punta serie extra corta con placchetta brasata in MD affilatura a 4 facce
- Spiralbohrer kurz mit gelöteter HM-Schneide
- Extra korte spiraalboor met 4-vlaks geslepen HM punt
- Foret extra-court avec partie carbure rectifiée et brasée sur 4 facettes

Tenone secondo DiN 1809
mit Mitnehmer DIN 1809
Met lip DIN 1809
Tenon selon la DIN 1809

A124	▪	3.1	3.2	3.3	3.4														
	•	1.5	1.6	2.2	2.3	4.1	4.2	4.3	5.1	5.2	5.3	6.2	6.3	6.4	8.2	9.1			

A124

HSS
HM

DIN
8037

2.5XD

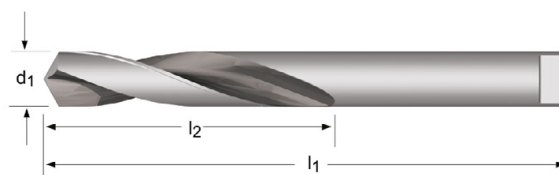

A124



3.00 - 16.00

d_1 Ø mm	d_1 decimal Inch	l_2 mm	l_1 mm	A124
3.00	0.1181	20	50	A1243.0
3.20	0.1260	25	56	A1243.2
3.50	0.1378	25	56	A1243.5
4.00	0.1575	25	56	A1244.0
4.20	0.1654	28	63	A1244.2
4.50	0.1772	28	63	A1244.5
4.80	0.1890	28	63	A1244.8
5.00	0.1969	28	63	A1245.0
5.20	0.2047	32	71	A1245.2
5.50	0.2165	32	71	A1245.5
5.80	0.2283	32	71	A1245.8
6.00	0.2362	32	71	A1246.0
6.50	0.2559	32	71	A1246.5
6.80	0.2677	40	80	A1246.8
7.00	0.2756	40	80	A1247.0
7.50	0.2953	40	80	A1247.5
8.00	0.3150	40	80	A1248.0
8.50	0.3346	50	90	A1248.5
9.00	0.3543	50	90	A1249.0
9.50	0.3740	50	90	A1249.5
10.00	0.3937	56	100	A12410.0
10.50	0.4134	56	100	A12410.5
11.00	0.4331	56	100	A12411.0
11.50	0.4528	63	112	A12411.5
12.00	0.4724	63	112	A12412.0
13.00	0.5118	63	112	A12413.0
14.00	0.5512	71	125	A12414.0
15.00	0.5906	71	125	A12415.0
16.00	0.6299	80	140	A12416.0

A720

- Micropunte
- Microbohrer
- Microboor
- Micro foret

A720	▪	1.1	1.2	1.3	1.4	3.1	3.2															
	•	1.5	1.6	2.1	2.2	2.3	3.3	3.4	4.1	4.2	4.3	5.1	5.2	5.3	6.1	6.2	6.3	6.4	7.1	7.2	7.3	
		7.4	8.1	8.2																		

A720 HSS-E **DIN 1899** 2.5XD **118°** N



d_1 Ø mm	d_1 decimal Inch	l_2 mm	l_1 mm	d_2 Ø mm	A720
0.15	0.0059	1.0	25	1	A720.15
0.16	0.0063	1.4	25	1	A720.16
0.17	0.0067	1.4	25	1	A720.17
0.18	0.0070	1.4	25	1	A720.18
0.20	0.0078	1.8	25	1	A720.2
0.22	0.0087	1.8	25	1	A720.22
0.25	0.0098	2.2	25	1	A720.25
0.27	0.0106	2.2	25	1	A720.27
0.28	0.0110	2.2	25	1	A720.28
0.30	0.0118	2.2	25	1	A720.3
0.35	0.0138	2.8	25	1	A720.35
0.38	0.0150	2.8	25	1	A720.38
0.39	0.0154	3.6	25	1	A720.39
0.40	0.0157	3.6	25	1	A720.4
0.45	0.0177	3.6	25	1	A720.45
0.50	0.0197	4.0	25	1	A720.5
0.55	0.0217	4.5	25	1	A720.55
0.60	0.0236	4.5	25	1	A720.6
0.62	0.0244	5.0	25	1	A720.62
0.65	0.0256	5.0	25	1	A720.65
0.70	0.0276	5.6	25	1	A720.7
0.75	0.0295	5.6	25	1	A720.75
0.80	0.0315	6.3	25	1.5	A720.8
0.85	0.0335	6.3	25	1.5	A720.85
0.90	0.0354	7.1	25	1.5	A720.9
0.95	0.0374	7.1	25	1.5	A720.95
1.00	0.0394	8.0	25	1.5	A720.10
1.05	0.0413	8.0	25	1.5	A720.105
1.10	0.0433	9.0	25	1.5	A720.11
1.20	0.0472	10.0	25	1.5	A720.12
1.30	0.0512	10.0	25	1.5	A720.13
1.40	0.0551	11.2	25	1.5	A720.14

- A920**
- Punte PFX serie extra corta
 - PFX - Tieflochspiralbohrer, kurz
- A921**
- Extra korte PFX boor
 - Foret PFX extra-court

A920	▪	1.1	1.2	1.3	1.4	1.5	1.6	2.1	2.2	2.3	4.1	4.2	4.3	5.1	5.2	5.3	7.2
	•	3.1	3.2	3.3	3.4	6.1	6.2	6.3	6.4	7.1	7.3	7.4	8.1	8.2			
A921	▪	1.1	1.2	1.3	1.4	1.5	1.6	2.1	2.2	2.3	3.1	3.2	3.3	3.4	7.4		
	•	4.1	4.2	4.3	5.1	5.2	5.3	6.3	6.4								

A920	HSS-E	DIN ANSI	3XD	130°			W			
A921	HSS-E	DIN ANSI	3XD	130°	Alcrona Top		W			

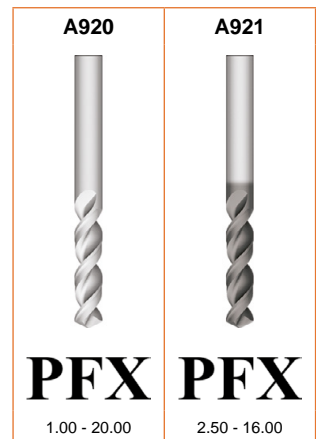
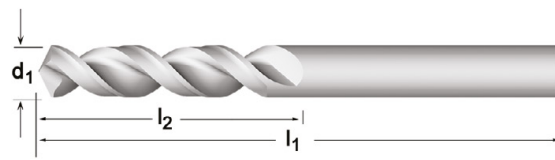

d_1 $\varnothing h_8$ Inch	d_1 $\varnothing h_8$ mm	d_1 decimal Inch	l_2 mm	l_1 mm	A920	A921
	1.00	0.0394	6	26	A9201.0	
	1.10	0.0433	7	28	A9201.1	
3/64	1.19	0.0469	13	35	A9203/64	
	1.20	0.0472	8	30	A9201.2	
	1.25	0.0492	8	30	A9201.25	
	1.30	0.0512	8	30	A9201.3	
	1.35	0.0531	9	32	A9201.35	
	1.40	0.0551	9	32	A9201.4	
	1.50	0.0591	9	32	A9201.5	
	1.55	0.0610	10	34	A9201.55	
1/16	1.59	0.0626	16	41	A9201/16	
	1.60	0.0630	10	34	A9201.6	
	1.70	0.0669	10	34	A9201.7	
	1.75	0.0689	11	36	A9201.75	
	1.80	0.0709	11	36	A9201.8	
	1.90	0.0748	11	36	A9201.9	
5/64	1.98	0.0780	17	43	A9205/64	
	2.00	0.0787	12	38	A9202.0	
	2.10	0.0827	12	38	A9202.1	
	2.15	0.0846	13	40	A9202.15	
	2.20	0.0866	13	40	A9202.2	
	2.30	0.0906	13	40	A9202.3	
	2.35	0.0925	14	43	A9202.35	
3/32	2.38	0.0937	19	41	A9203/32	
	2.40	0.0945	14	43	A9202.4	
	2.50	0.0984	14	43	A9202.5	A9212.5
	2.60	0.1024	14	43	A9202.6	A9212.6
	2.70	0.1063	16	46	A9202.7	A9212.7
7/64	2.78	0.1094	21	46	A9207/64	A9217/64
	2.80	0.1102	16	46	A9202.8	
	2.90	0.1142	16	46	A9202.9	A9212.9
	3.00	0.1181	16	46	A9203.0	A9213.0

d_1 Ø _{h8} Inch	d_1 Ø _{h8} mm	d_1 decimal Inch	l_2 mm	l_1 mm	A920	A921
1/8	3.10	0.1220	18	49	A9203.1	A9213.1
	3.18	0.1252	22	48	A9201/8	A9211/8
	3.20	0.1260	18	49	A9203.2	A9213.2
	3.30	0.1299	18	49	A9203.3	A9213.3
	3.40	0.1339	20	52	A9203.4	A9213.4
9/64	3.50	0.1378	20	52	A9203.5	A9213.5
	3.57	0.1406	24	49	A9209/64	A9219/64
	3.60	0.1417	20	52	A9203.6	A9213.6
	3.70	0.1457	20	52	A9203.7	A9213.7
	3.80	0.1496	22	55	A9203.8	A9213.8
5/32	3.90	0.1535	22	55	A9203.9	A9213.9
	3.97	0.1563	25	52	A9205/32	A9215/32
	4.00	0.1575	22	55	A9204.0	A9214.0
	4.10	0.1614	22	55	A9204.1	A9214.1
	4.20	0.1654	22	55	A9204.2	A9214.2
11/64	4.30	0.1693	24	58	A9204.3	A9214.3
	4.37	0.1720	27	54	A92011/64	A92111/64
	4.40	0.1732	24	58	A9204.4	A9214.4
	4.50	0.1772	24	58	A9204.5	A9214.5
	4.60	0.1811	24	58	A9204.6	A9214.6
3/16	4.70	0.1850	24	58	A9204.7	A9214.7
	4.76	0.1874	29	56	A9203/16	A9213/16
	4.80	0.1890	26	62	A9204.8	A9214.8
	4.90	0.1929	26	62	A9204.9	A9214.9
	5.00	0.1969	26	62	A9205.0	A9215.0
13/64	5.10	0.2008	26	62	A9205.1	A9215.1
	5.16	0.2031	30	57	A92013/64	A92113/64
	5.20	0.2047	26	62	A9205.2	A9215.2
	5.30	0.2087	26	62	A9205.3	A9215.3
	5.40	0.2126	28	66	A9205.4	A9215.4
7/32	5.50	0.2165	28	66	A9205.5	A9215.5
	5.56	0.2189	32	60	A9207/32	A9217/32
	5.60	0.2205	28	66	A9205.6	A9215.6
	5.70	0.2244	28	66	A9205.7	A9215.7
	5.80	0.2283	28	66	A9205.8	A9215.8
15/64	5.90	0.2323	28	66	A9205.9	A9215.9
	5.95	0.2343	33	62	A92015/64	A92115/64
	6.00	0.2362	28	66	A9206.0	A9216.0
	6.10	0.2402	31	70	A9206.1	A9216.1
	6.20	0.2441	31	70	A9206.2	A9216.2
1/4	6.30	0.2480	31	70	A9206.3	A9216.3
	6.35	0.2500	35	64	A9201/4	A9211/4
	6.40	0.2520	31	70	A9206.4	A9216.4
	6.50	0.2559	31	70	A9206.5	A9216.5
	6.60	0.2598	31	70	A9206.6	A9216.6
17/64	6.70	0.2638	31	70	A9206.7	A9216.7
	6.75	0.2657	37	67	A92017/64	A92117/64
	6.80	0.2677	34	74	A9206.8	A9216.8
	6.90	0.2717	34	74	A9206.9	A9216.9
	7.00	0.2756	34	74	A9207.0	A9217.0
9/32	7.10	0.2795	34	74	A9207.1	A9217.1
	7.14	0.2811	38	68	A9209/32	A9219/32
	7.20	0.2835	34	74	A9207.2	A9217.2
	7.30	0.2874	34	74	A9207.3	A9217.3
	7.40	0.2913	34	74	A9207.4	A9217.4
19/64	7.50	0.2953	34	74	A9207.5	A9217.5
	7.54	0.2969	40	70	A92019/64	A92119/64
	7.60	0.2992	37	79	A9207.6	A9217.6
	7.70	0.3031	37	79	A9207.7	A9217.7
	7.80	0.3071	37	79	A9207.8	A9217.8
5/16	7.90	0.3110	37	79	A9207.9	A9217.9
	7.94	0.3126	41	71	A9205/16	A9215/16
	8.00	0.3150	37	79	A9208.0	A9218.0
	8.10	0.3189	37	79	A9208.1	A9218.1
	8.20	0.3228	37	79	A9208.2	A9218.2
21/64	8.30	0.3268	37	79	A9208.3	A9218.3
	8.33	0.3280	43	75	A92021/64	A92121/64
	8.40	0.3307	37	79	A9208.4	A9218.4
	8.50	0.3346	37	79	A9208.5	A9218.5
	8.60	0.3386	40	84	A9208.6	A9218.6

d_1 $\varnothing h_8$ Inch	d_1 $\varnothing h_8$ mm	d_1 decimal Inch	l_2 mm	l_1 mm	A920	A921
11/32	8.70	0.3425	40	84	A9208.7	A9218.7
	8.73	0.3437	43	76	A92011/32	A92111/32
	8.80	0.3465	40	84	A9208.8	A9218.8
	8.90	0.3504	40	84	A9208.9	A9218.9
	9.00	0.3543	40	84	A9209.0	A9219.0
23/64	9.10	0.3583	40	84	A9209.1	A9219.1
	9.13	0.3594	44	78	A92023/64	A92123/64
	9.20	0.3622	40	84	A9209.2	A9219.2
	9.30	0.3661	40	84	A9209.3	A9219.3
	9.40	0.3701	40	84	A9209.4	A9219.4
3/8	9.50	0.3740	40	84	A9209.5	A9219.5
	9.52	0.3748	46	79	A9203/8	A9213/8
	9.60	0.3780	43	89	A9209.6	A9219.6
	9.70	0.3819	43	89	A9209.7	A9219.7
	9.80	0.3858	43	89	A9209.8	A9219.8
25/64	9.90	0.3898	43	89	A9209.9	A9219.9
	9.92	0.3906	48	83	A92025/64	A92125/64
	10.00	0.3937	43	89	A92010.0	A92110.0
	10.20	0.4016	43	89	A92010.2	A92110.2
	10.30	0.4055	43	89	A92010.3	A92110.3
13/32	10.32	0.4063	49	84	A92013/32	A92113/32
	10.50	0.4134	43	89	A92010.5	A92110.5
	10.72	0.4220	51	86	A92027/64	A92127/64
27/64	10.80	0.4252	47	95	A92010.8	A92110.8
	11.00	0.4331	47	95	A92011.0	A92111.0
	11.11	0.4374	52	87	A9207/16	A9217/16
7/16	11.50	0.4528	47	95	A92011.5	A92111.5
	11.51	0.4531	54	90	A92029/64	A92129/64
	11.80	0.4646	47	95	A92011.8	A92111.8
15/32	11.91	0.4689	54	92	A92015/32	A92115/32
	12.00	0.4724	51	102	A92012.0	A92112.0
	12.20	0.4803	51	102	A92012.2	
31/64	12.30	0.4843	56	94	A92031/64	A92131/64
	12.50	0.4921	51	102	A92012.5	A92112.5
	12.70	0.5000	57	95	A9201/2	A9211/2
1/2	13.00	0.5118	51	102	A92013.0	A92113.0
	13.10	0.5157	60	98	A92033/64	A92133/64
	13.50	0.5315	54	107	A92013.5	A92113.5
33/64	13.89	0.5469	64	102	A92035/64	A92135/64
	14.00	0.5512	54	107	A92014.0	A92114.0
	14.29	0.5626	64	102	A9209/16	A9219/16
9/16	14.50	0.5709	56	111	A92014.5	A92114.5
	14.68	0.5780	67	105	A92037/64	A92137/64
	14.75	0.5807	56	111	A92014.75	A92114.75
37/64	15.00	0.5906	56	111	A92015.0	A92115.0
	15.08	0.5937	67	105	A92019/32	A92119/32
	15.48	0.6094	70	108	A92039/64	A92139/64
5/8	15.50	0.6102	58	115	A92015.5	A92115.5
	15.88	0.6252	70	108	A9205/8	A9215/8
	16.00	0.6299	58	115	A92016.0	A92116.0
41/64	16.27	0.6406	73	114	A92041/64	
	16.50	0.6496	60	119	A92016.5	
	16.67	0.6563	73	114	A92021/32	
21/32	16.75	0.6594	60	119	A92016.75	
	17.00	0.6693	60	119	A92017.0	
	17.07	0.6720	73	117	A92043/64	
43/64	17.46	0.6874	73	117	A92011/16	
	17.50	0.6890	62	123	A92017.5	
	17.86	0.7031	76	121	A92045/64	
45/64	18.00	0.7087	62	123	A92018.0	
	18.26	0.7189	76	121	A92023/32	
	18.50	0.7283	64	127	A92018.5	
23/32	18.65	0.7343	79	127	A92047/64	
	19.00	0.7480	64	127	A92019.0	
	19.05	0.7500	79	127	A9203/4	
49/64	19.45	0.7657	83	130	A92049/64	
	19.50	0.7677	66	131	A92019.5	
	19.84	0.7811	83	130	A92025/32	
25/32	20.00	0.7874	66	131	A92020.0	

A002

- Punta serie corta Autocentrante
- 002 Spiralbohrer
- Korte spiraalboor met Split Point
- Foret court avec affûtage en croix

Lucida sotto i 2mm, con rivestimento parziale TiN e affilatura split point da 2mm in su
 Blank bis 2.0 mm, TiN-tip beschichtet mit Kreuzanschliff ab 2,0 mm
 Blank tot 2.0 mm, TiN-Tip gecoat met kruisslijping vanaf 2.0 mm
 Brillant en dessous de 2,0mm, TIN en pointe et affutage en croix au dessus de 2,0 mm

A002S

- Punta serie corta Autocentrante - in confezione singola
- 002 Spiralbohrer - Einzelverpackung
- Korte spiraalboor met Split Point - blisterverpakking
- Foret court avec affûtage en croix - en blister

Con rivestimento parziale TiN
 TiN-Tip beschichtet
 TiN-Tip gecoat
 TIN en pointe

A100

- Punta serie corta
- Spiralbohrer
- Spiraalboor
- Foret court

Senza trattamento sotto 1,0 mm , 3/64", N60
 Blank bis 1 mm Ø, N60
 Blank beneden 1,0mm, 3/16", N60
 Brillant au dessous de 1,0, 3/64, N60

A101

- Punta serie corta - sinistra
- Spiralbohrer - Linksschneidend
- Korte spiraalboor
- Foret court - à gauche

Senza trattamento sotto 3,0 mm
 Blank bis 3 mm Ø
 Blank beneden 3,0mm
 Brillant au dessous de 3,0 mm

A002; A002S	▪	1.1	1.2	1.3	1.4	3.1	3.2	7.1	7.2	8.1	8.2								
	•	1.5	1.6	2.1	2.2	2.3	3.3	3.4	4.1	4.2	4.3	5.1	5.2	5.3	6.1	6.2	6.3	6.4	7.3
		9.1																	
A100; A101	▪	1.1	1.2	1.3	1.4	3.1	3.2												
	•	1.5	1.6	2.1	2.2	2.3	3.3	3.4	4.1	4.2	4.3	5.1	5.2	5.3	6.1	6.2	6.3	6.4	7.1
		7.4	8.1	8.2	8.3	9.1													

A002	HSS	DIN 338	4XD	118°	TiN		N												
A002S	HSS	DIN 338	4XD	118°	TiN		N												
A100	HSS	DIN 338	4XD	118°	ST		N												
A101	HSS	DIN 338	4XD	118°	ST		N												

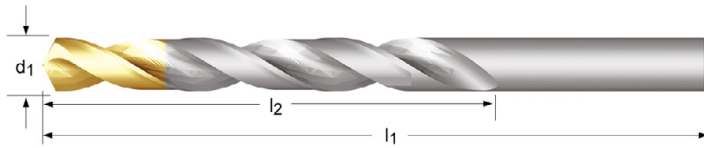

d_1 $\varnothing h_8$ "/Nr./letter	d_1 $\varnothing h_8$ mm	d_1 decimal Inch	l_2 mm	l_1 mm	A002	A002S	A100	A101
	0.20	0.0079	2.5	19			A100.2	
	0.25	0.0098	3	19			A100.25	
	0.30	0.0118	3	19			A100.3	
	0.32	0.0126	4	19			A100.32	
80	0.34	0.0134	4	19			A100N80	
	0.35	0.0138	4	19			A100.35	
79	0.37	0.0146	4	19			A100N79	
	0.38	0.0150	4	19			A100.38	
1/64	0.40	0.0157	5	20			A1001/64	
	0.40	0.0157	5	20			A100.4	
78	0.41	0.0161	5	20			A100N78	
	0.42	0.0165	5	20			A100.42	
	0.45	0.0177	5	20			A100.45	
77	0.46	0.0181	5	20			A100N77	
	0.48	0.0189	5	20			A100.48	
	0.50	0.0197	6	22			A100.5	
76	0.51	0.0201	6	22			A100N76	
	0.52	0.0205	6	22			A100.52	
75	0.53	0.0209	6	22			A100N75	
	0.55	0.0217	7	24			A100.55	
74	0.57	0.0224	7	24			A100N74	
	0.58	0.0228	7	24			A100.58	
	0.60	0.0236	7	24			A100.6	
73	0.61	0.0240	8	26			A100N73	
	0.62	0.0244	8	26			A100.62	
72	0.64	0.0252	8	26			A100N72	
	0.65	0.0256	8	26			A100.65	
71	0.66	0.0260	8	26			A100N71	
	0.68	0.0268	9	28			A100.68	
	0.70	0.0276	9	28			A100.7	
70	0.71	0.0280	9	28			A100N70	
	0.72	0.0283	9	28			A100.72	
69	0.74	0.0291	9	28			A100N69	
	0.75	0.0295	9	28			A100.75	
68	0.79	0.0311	10	30			A100N68	
	0.78	0.0307	10	30			A100.78	
1/32	0.79	0.0311	10	30			A1001/32	
	0.80	0.0315	10	30			A100.8	
67	0.81	0.0319	10	30			A100N67	
	0.82	0.0323	10	30			A100.82	
66	0.84	0.0331	10	30			A100N66	
	0.85	0.0335	10	30			A100.85	
	0.88	0.0346	11	32			A100.88	
65	0.89	0.0350	11	32			A100N65	
	0.90	0.0354	11	32			A100.9	
64	0.91	0.0358	11	32			A100N64	
	0.92	0.0362	11	32			A100.92	
63	0.94	0.0370	11	32			A100N63	

d_1 $\varnothing h_8$ "/Nr./letter	d_1 $\varnothing h_8$ mm	d_1 decimal Inch	l_2 mm	l_1 mm	A002	A002S	A100	A101
	0.95	0.0374	11	32			A100.95	
62	0.97	0.0382	12	34			A100N62	
	0.98	0.0386	12	34			A100.98	
61	0.99	0.0390	12	34			A100N61	
	1.00	0.0394	12	34	A0021.0		A1001.0	A1011.0
60	1.02	0.0402	12	34			A100N60	
59	1.04	0.0409	12	34			A100N59	
	1.05	0.0413	12	34			A1001.05	
58	1.07	0.0421	14	36			A100N58	
57	1.09	0.0429	14	36			A100N57	
	1.10	0.0433	14	36	A0021.1		A1001.1	A1011.1
	1.15	0.0453	14	36			A1001.15	
56	1.18	0.0465	14	36			A100N56	
3/64	1.19	0.0469	16	38	A0023/64		A1003/64	
	1.20	0.0472	16	38	A0021.2		A1001.2	A1011.2
	1.25	0.0492	16	38			A1001.25	A1011.25
	1.30	0.0512	16	38	A0021.3		A1001.3	A1011.3
55	1.32	0.0520	16	38			A100N55	
	1.35	0.0531	18	40			A1001.35	
	1.40	0.0551	18	40	A0021.4		A1001.4	A1011.4
54	1.40	0.0551	18	40			A100N54	
	1.45	0.0571	18	40			A1001.45	
	1.50	0.0591	18	40	A0021.5		A1001.5	A1011.5
53	1.51	0.0594	20	43			A100N53	
	1.55	0.0610	20	43			A1001.55	
1/16	1.59	0.0626	20	43	A0021/16		A1001/16	
	1.60	0.0630	20	43	A0021.6		A1001.6	A1011.6
52	1.61	0.0634	20	43			A100N52	
	1.65	0.0650	20	43			A1001.65	
	1.70	0.0669	20	43	A0021.7		A1001.7	A1011.7
51	1.70	0.0669	22	46			A100N51	
	1.75	0.0689	22	46			A1001.75	
50	1.78	0.0701	22	46			A100N50	
	1.80	0.0709	22	46	A0021.8		A1001.8	A1011.8
	1.85	0.0728	22	46			A1001.85	
49	1.85	0.0728	22	46			A100N49	
	1.90	0.0748	22	46	A0021.9		A1001.9	A1011.9
48	1.93	0.0760	24	49			A100N48	
	1.95	0.0768	24	49			A1001.95	
5/64	1.98	0.0780	24	49	A0025/64		A1005/64	
47	1.99	0.0783	24	49			A100N47	
	2.00	0.0787	24	49	A0022.0	A002S2.0 ²⁾	A1002.0	A1012.0
	2.05	0.0807	24	49			A1002.05	
46	2.06	0.0811	24	49			A100N46	
45	2.08	0.0819	24	49			A100N45	
	2.10	0.0827	24	49	A0022.1		A1002.1	A1012.1
	2.15	0.0846	27	53			A1002.15	
44	2.18	0.0858	27	53			A100N44	
	2.20	0.0866	27	53	A0022.2		A1002.2	A1012.2
	2.25	0.0886	27	53			A1002.25	
43	2.26	0.0890	27	53			A100N43	
	2.30	0.0906	27	53	A0022.3		A1002.3	A1012.3
	2.35	0.0925	27	53			A1002.35	
42	2.38	0.0937	30	57			A100N42	
3/32	2.38	0.0937	30	57	A0023/32		A1003/32	
	2.40	0.0945	30	57	A0022.4		A1002.4	A1012.4
41	2.44	0.0961	30	57			A100N41	
	2.45	0.0965	30	57			A1002.45	
40	2.49	0.0980	30	57			A100N40	
	2.50	0.0984	30	57	A0022.5	A002S2.5 ²⁾	A1002.5	A1012.5
39	2.53	0.0996	30	57			A100N39	
	2.55	0.1004	30	57			A1002.55	
38	2.58	0.1016	30	57			A100N38	
	2.60	0.1024	30	57	A0022.6		A1002.6	A1012.6
37	2.64	0.1039	30	57			A100N37	
	2.65	0.1043	30	57			A1002.65	
	2.70	0.1063	33	61	A0022.7		A1002.7	A1012.7
36	2.71	0.1067	33	61			A100N36	

d ₁ Øh ₈ "/Nr./letter	d ₁ Øh ₈ mm	d ₁ decimal Inch	l ₂ mm	l ₁ mm	A002	A002S	A100	A101
	2.75	0.1083	33	61			A1002.75	
7/64	2.78	0.1094	33	61	A0027/64		A1007/64	
35	2.79	0.1098	33	61			A100N35	
	2.80	0.1102	33	61	A0022.8		A1002.8	A1012.8
34	2.82	0.1110	33	61			A100N34	
	2.85	0.1122	33	61			A1002.85	
33	2.87	0.1130	33	61			A100N33	
	2.90	0.1142	33	61	A0022.9		A1002.9	A1012.9
	2.95	0.1161	33	61			A1002.95	
32	2.95	0.1161	33	61			A100N32	
	3.00	0.1181	33	61	A0023.0	A002S3.0 ²⁾	A1003.0	A1013.0
31	3.05	0.1201	36	65			A100N31	
	3.10	0.1220	36	65	A0023.1		A1003.1	
	3.15	0.1240	36	65			A1003.15	
1/8	3.18	0.1252	36	65	A0021/8	A002S1/8 ²⁾	A1001/8	
	3.20	0.1260	36	65	A0023.2	A002S3.2 ²⁾	A1003.2	A1013.2
	3.25	0.1280	36	65	A0023.25		A1003.25	
30	3.26	0.1283	36	65			A100N30	
	3.30	0.1299	36	65	A0023.3	A002S3.3 ²⁾	A1003.3	A1013.3
	3.40	0.1339	39	70	A0023.4		A1003.4	
29	3.45	0.1358	39	70			A100N29	
	3.50	0.1378	39	70	A0023.5	A002S3.5 ²⁾	A1003.5	A1013.5
28	3.57	0.1406	39	70			A100N28	
9/64	3.57	0.1406	39	70	A0029/64		A1009/64	
	3.60	0.1417	39	70	A0023.6		A1003.6	
27	3.66	0.1441	39	70			A100N27	
	3.70	0.1457	39	70	A0023.7		A1003.7	
26	3.73	0.1469	39	70			A100N26	
	3.75	0.1476	39	70			A1003.75	
	3.80	0.1496	43	75	A0023.8		A1003.8	A1013.8
25	3.80	0.1496	43	75			A100N25	
24	3.86	0.1520	43	75			A100N24	
	3.90	0.1535	43	75	A0023.9		A1003.9	
23	3.91	0.1539	43	75			A100N23	
5/32	3.97	0.1563	43	75	A0025/32	A002S5/32 ²⁾	A1005/32	
22	3.99	0.1571	43	75			A100N22	
	4.00	0.1575	43	75	A0024.0	A002S4.0 ²⁾	A1004.0	A1014.0
21	4.04	0.1591	43	75			A100N21	
20	4.09	0.1610	43	75			A100N20	
	4.10	0.1614	43	75	A0024.1	A002S4.1 ²⁾	A1004.1	
	4.20	0.1654	43	75	A0024.2	A002S4.2 ²⁾	A1004.2	A1014.2
19	4.22	0.1661	43	75			A100N19	
	4.25	0.1673	43	75			A1004.25	
	4.30	0.1693	47	80	A0024.3		A1004.3	
18	4.31	0.1697	47	80			A100N18	
11/64	4.37	0.1720	47	80	A00211/64		A10011/64	
17	4.39	0.1728	47	80			A100N17	
	4.40	0.1732	47	80	A0024.4		A1004.4	
	4.50	0.1772	47	80	A0024.5	A002S4.5 ²⁾	A1004.5	A1014.5
16	4.50	0.1772	47	80			A100N16	
15	4.57	0.1799	47	80			A100N15	
	4.60	0.1811	47	80	A0024.6		A1004.6	
14	4.62	0.1819	47	80			A100N14	
	4.70	0.1850	47	80	A0024.7		A1004.7	
13	4.70	0.1850	47	80			A100N13	
	4.75	0.1870	47	80			A1004.75	
3/16	4.76	0.1874	52	86	A0023/16	A002S3/16 ²⁾	A1003/16	
	4.80	0.1890	52	86	A0024.8		A1004.8	A1014.8
12	4.80	0.1890	52	86			A100N12	
11	4.85	0.1909	52	86			A100N11	
	4.90	0.1929	52	86	A0024.9		A1004.9	
10	4.92	0.1937	52	86			A100N10	
9	4.98	0.1961	52	86			A100N9	
	5.00	0.1969	52	86	A0025.0	A002S5.0 ²⁾	A1005.0	A1015.0
8	5.06	0.1992	52	86			A100N8	
	5.10	0.2008	52	86	A0025.1		A1005.1	A1015.1
7	5.11	0.2012	52	86			A100N7	
13/64	5.16	0.2031	52	86	A00213/64	A002S13/64	A10013/64	

d_1 $\varnothing h_8$ "/Nr./letter	d_1 $\varnothing h_8$ mm	d_1 decimal Inch	l_2 mm	l_1 mm	A002	A002S	A100	A101
6	5.18	0.2039	52	86			A100N6	
	5.20	0.2047	52	86	A0025.2		A1005.2	A1015.2
5	5.22	0.2055	52	86			A100N5	
	5.25	0.2067	52	86			A1005.25	
	5.30	0.2087	52	86	A0025.3		A1005.3	
4	5.31	0.2091	57	93			A100N4	
	5.40	0.2126	57	93	A0025.4		A1005.4	
3	5.41	0.2130	57	93			A100N3	
	5.50	0.2165	57	93	A0025.5	A002S5.5	A1005.5	A1015.5
	7/32	5.56	0.2189	57	A0027/32	A002S7/32	A1007/32	
2	5.60	0.2205	57	93	A0025.6		A1005.6	
	5.61	0.2209	57	93			A100N2	
	5.70	0.2244	57	93	A0025.7		A1005.7	
	5.75	0.2264	57	93			A1005.75	
1	5.79	0.2280	57	93			A100N1	
	5.80	0.2283	57	93	A0025.8		A1005.8	
	5.90	0.2323	57	93	A0025.9		A1005.9	
A	5.94	0.2339	57	93			A100A	
	15/64	5.95	0.2343	57	A00215/64		A10015/64	
B	6.00	0.2362	57	93	A0026.0	A002S6.0	A1006.0	A1016.0
	6.03	0.2374	63	101			A100B	
	6.10	0.2402	63	101	A0026.1		A1006.1	
C	6.15	0.2421	63	101			A100C	
	6.20	0.2441	63	101	A0026.2		A1006.2	
	6.25	0.2461	63	101			A1006.25	
D	6.25	0.2461	63	101			A100D	
	6.30	0.2480	63	101	A0026.3		A1006.3	
	1/4	6.35	0.2500	63	A0021/4	A002S1/4	A1001/4	
E	6.35	0.2500	63	101			A100E	
	6.40	0.2520	63	101	A0026.4		A1006.4	
	6.50	0.2559	63	101	A0026.5	A002S6.5	A1006.5	A1016.5
F	6.53	0.2571	63	101			A100F	
	6.60	0.2598	63	101	A0026.6		A1006.6	
	G	6.63	0.2610	63	101		A100G	
17/64	6.70	0.2638	63	101	A0026.7		A1006.7	
	6.75	0.2657	69	109	A00217/64	A002S17/64	A10017/64	
	6.75	0.2657	69	109			A1006.75	
H	6.76	0.2661	69	109			A100H	
	6.80	0.2677	69	109	A0026.8	A002S6.8	A1006.8	
	6.90	0.2717	69	109	A0026.9		A1006.9	
I	6.91	0.2720	69	109			A100I	
	7.00	0.2756	69	109	A0027.0	A002S7.0	A1007.0	A1017.0
J	7.04	0.2772	69	109			A100J	
	7.10	0.2795	69	109	A0027.1		A1007.1	
K	7.14	0.2811	69	109			A100K	
	9/32	7.14	0.2811	69	A0029/32		A1009/32	
	7.20	0.2835	69	109	A0027.2		A1007.2	
	7.25	0.2854	69	109			A1007.25	
	7.30	0.2874	69	109	A0027.3		A1007.3	
L	7.37	0.2902	69	109			A100L	
	7.40	0.2913	69	109	A0027.4		A1007.4	
M	7.49	0.2949	69	109			A100M	
	7.50	0.2953	69	109	A0027.5	A002S7.5	A1007.5	A1017.5
	19/64	7.54	0.2969	75	A00219/64		A10019/64	
N	7.60	0.2992	75	117	A0027.6		A1007.6	
	7.67	0.3020	75	117			A100N	
	7.70	0.3031	75	117	A0027.7		A1007.7	
	7.75	0.3051	75	117			A1007.75	
	7.80	0.3071	75	117	A0027.8		A1007.8	
	7.90	0.3110	75	117	A0027.9		A1007.9	
	5/16	7.94	0.3126	75	A0025/16	A002S5/16	A1005/16	
	8.00	0.3150	75	117	A0028.0	A002S8.0	A1008.0	A1018.0
O	8.03	0.3161	75	117			A100O	
	8.10	0.3189	75	117	A0028.1		A1008.1	
	8.20	0.3228	75	117	A0028.2	A002S8.2	A1008.2	
P	8.20	0.3228	75	117			A100P	
	8.25	0.3248	75	117			A1008.25	
	8.30	0.3268	75	117	A0028.3		A1008.3	
21/64	8.33	0.3280	75	117	A00221/64		A10021/64	
	8.40	0.3307	75	117	A0028.4		A1008.4	

d ₁ Øh ₈ "/Nr./letter	d ₁ Øh ₈ mm	d ₁ decimal Inch	l ₂ mm	l ₁ mm	A002	A002S	A100	A101
Q	8.43	0.3319	75	117			A100Q	
	8.50	0.3346	75	117	A0028.5	A002S8.5	A1008.5	A1018.5
	8.60	0.3386	81	125	A0028.6		A1008.6	
R	8.61	0.3390	81	125			A100R	
	8.70	0.3425	81	125	A0028.7		A1008.7	
11/32	8.73	0.3437	81	125	A00211/32		A10011/32	
	8.75	0.3445	81	125			A1008.75	
	8.80	0.3465	81	125	A0028.8		A1008.8	
S	8.84	0.3480	81	125			A100S	
	8.90	0.3504	81	125	A0028.9		A1008.9	
	9.00	0.3543	81	125	A0029.0	A002S9.0	A1009.0	A1019.0
T	9.09	0.3579	81	125			A100T	
	9.10	0.3583	81	125	A0029.1		A1009.1	
23/64	9.13	0.3594	81	125	A00223/64		A10023/64	
	9.20	0.3622	81	125	A0029.2		A1009.2	
	9.25	0.3642	81	125			A1009.25	
	9.30	0.3661	81	125	A0029.3		A1009.3	
U	9.35	0.3681	81	125			A100U	
	9.40	0.3701	81	125	A0029.4		A1009.4	
	9.50	0.3740	81	125	A0029.5	A002S9.5	A1009.5	
3/8	9.52	0.3748	87	133	A0023/8	A002S3/8	A1003/8	
V	9.58	0.3772	87	133			A100V	
	9.60	0.3780	87	133	A0029.6		A1009.6	
	9.70	0.3819	87	133	A0029.7		A1009.7	
	9.75	0.3839	87	133			A1009.75	
	9.80	0.3858	87	133	A0029.8		A1009.8	
W	9.80	0.3858	87	133			A100W	
	9.90	0.3898	87	133	A0029.9		A1009.9	
25/64	9.92	0.3906	87	133	A00225/64		A10025/64	
	10.00	0.3937	87	133	A00210.0	A002S10.0	A10010.0	A10110.0
X	10.08	0.3969	87	133			A100X	
	10.10	0.3976	87	133	A00210.1		A10010.1	
	10.20	0.4016	87	133	A00210.2	A002S10.2	A10010.2	
	10.25	0.4035	87	133			A10010.25	
Y	10.26	0.4039	87	133			A100Y	
	10.30	0.4055	87	133	A00210.3		A10010.3	
13/32	10.32	0.4063	87	133	A00213/32		A10013/32	
	10.40	0.4094	87	133	A00210.4		A10010.4	
Z	10.49	0.4130	87	133			A100Z	
	10.50	0.4134	87	133	A00210.5	A002S10.5	A10010.5	
	10.60	0.4173	87	133	A00210.6		A10010.6	
	10.70	0.4213	94	142	A00210.7		A10010.7	
27/64	10.72	0.4220	94	142	A00227/64		A10027/64	
	10.75	0.4232	94	142			A10010.75	
	10.80	0.4252	94	142	A00210.8		A10010.8	
	10.90	0.4291	94	142	A00210.9		A10010.9	
	11.00	0.4331	94	142	A00211.0	A002S11.0	A10011.0	A10111.0
	11.10	0.4370	94	142	A00211.1		A10011.1	
7/16	11.11	0.4374	94	142	A0027/16		A1007/16	
	11.20	0.4409	94	142	A00211.2		A10011.2	
	11.25	0.4429	94	142			A10011.25	
	11.30	0.4449	94	142	A00211.3		A10011.3	
	11.40	0.4488	94	142	A00211.4		A10011.4	
	11.50	0.4528	94	142	A00211.5	A002S11.5	A10011.5	
29/64	11.51	0.4531	94	142	A00229/64		A10029/64	
	11.60	0.4567	94	142	A00211.6		A10011.6	
	11.70	0.4606	94	142	A00211.7		A10011.7	
	11.75	0.4626	94	142			A10011.75	
	11.80	0.4646	94	142	A00211.8		A10011.8	
	11.90	0.4685	101	151	A00211.9		A10011.9	
15/32	11.91	0.4689	101	151	A00215/32		A10015/32	
	12.00	0.4724	101	151	A00212.0	A002S12.0	A10012.0	A10112.0
	12.10	0.4764	101	151	A00212.1		A10012.1	
	12.20	0.4803	101	151	A00212.2		A10012.2	
	12.25	0.4823	101	151			A10012.25	
	12.30	0.4843	101	151	A00212.3		A10012.3	
31/64	12.30	0.4843	101	151	A00231/64		A10031/64	
	12.40	0.4882	101	151	A00212.4		A10012.4	
	12.50	0.4921	101	151	A00212.5	A002S12.5	A10012.5	
	12.60	0.4961	101	151	A00212.6		A10012.6	

d_1 $\varnothing h_8$ "/Nr./letter	d_1 $\varnothing h_8$ mm	d_1 decimal Inch	l_2 mm	l_1 mm	A002	A002S	A100	A101	
1/2	12.70	0.5000	101	151	A00212.7		A10012.7		
	12.70	0.5000	101	151	A0021/2	A002S1/2	A1001/2		
	12.75	0.5020	101	151			A10012.75		
	12.80	0.5039	101	151	A00212.8		A10012.8		
33/64	12.90	0.5079	101	151	A00212.9		A10012.9		
	13.00	0.5118	101	151	A00213.0	A002S13.0	A10013.0		
	13.10	0.5157	101	151	A00233/64		A10033/64		
	13.10	0.5157	101	151	A00213.1		A10013.1		
	13.20	0.5197	101	151	A00213.2		A10013.2		
	13.25	0.5217	108	160	A00213.25		A10013.25		
	13.30	0.5236	108	160	A00213.3		A10013.3		
	13.40	0.5276	108	160	A00213.4		A10013.4		
	17/32	13.49	0.5311	108	160	A00217/32		A10017/32	
		13.50	0.5315	108	160	A00213.5		A10013.5	
35/64	13.60	0.5354	108	160	A00213.6		A10013.6		
	13.70	0.5394	108	160	A00213.7		A10013.7		
	13.75	0.5413	108	160	A00213.75		A10013.75		
	13.80	0.5433	108	160	A00213.8		A10013.8		
	13.89	0.5469	108	160	A00235/64		A10035/64		
	13.90	0.5472	108	160	A00213.9		A10013.9		
	14.00	0.5512	108	160	A00214.0		A10014.0		
	14.25	0.5610	114	169	A00214.25		A10014.25		
	9/16	14.29	0.5626	114	169	A0029/16		A1009/16	
		14.50	0.5709	114	169	A00214.5		A10014.5	
37/64	14.68	0.5780	114	169	A00237/64		A10037/64		
19/32	14.75	0.5807	114	169	A00214.75		A10014.75		
	15.00	0.5906	114	169	A00215.0		A10015.0		
	15.08	0.5937	120	178	A00219/32		A10019/32		
	15.25	0.6004	120	178	A00215.25		A10015.25		
39/64	15.48	0.6094	120	178	A00239/64		A10039/64		
5/8	15.50	0.6102	120	178	A00215.5		A10015.5		
	15.75	0.6201	120	178	A00215.75		A10015.75		
	15.88	0.6252	120	178	A0025/8		A1005/8		
	16.00	0.6299	120	178	A00216.0		A10016.0		
41/64	16.27	0.6406	125	184		A10041/64			
21/32	16.50	0.6496	125	184		A10016.5			
	16.67	0.6563	125	184		A10021/32			
43/64	17.00	0.6693	125	184		A10017.0			
	17.07	0.6720	130	191		A10043/64			
11/16	17.46	0.6874	130	191		A10011/16			
	17.50	0.6890	130	191		A10017.5			
	18.00	0.7087	130	191		A10018.0			
	18.50	0.7283	135	198		A10018.5			
	19.00	0.7480	135	198		A10019.0			
	19.50	0.7677	140	205		A10019.5			
	20.00	0.7874	140	205		A10020.0			

A108

- Punta serie corta
- Spiralbohrer
- Korte spiraalboor met kruisslijping
- Foret court à hélice rapide

Affilatura a diamante 1,6 mm, 1/16" e diametri maggiori
Kreuzanschliff ab 1,6 mm Ø
Kruisslijping boven 1,6 mm, 1/16"
Affûtage en croix au dessus de 1,6 mm, 1/16

A147

- Punta serie corta
- Spiralbohrer
- Spiraalboor
- Foret court

A777

- Punta serie corta
- Spiralbohrer
- Korte spiraalboor met kruisslijping
- Foret court (8% cobalt)

Affilatura a 4 facce fino a 1,4 mm
4Flächenanschliff bis 1,4 mm Ø
Viervlaks punt vanaf 1,4 mm
Pointe à 4 facettes jusqu'au Ø 1,4 mm

A108	▪	2.2	2.3	4.1	4.2																	
	•	1.1	1.2	1.3	1.4	1.5	1.6	2.1	3.1	3.2	3.3	3.4	4.3	5.1	5.2	5.3	6.1	6.2	6.3	6.4	7.1	
		7.2	7.3	7.4	8.1	8.2	8.3	9.1														
A147	▪	2.1	2.2	2.3	4.1	4.2	5.1															
	•	1.1	1.2	1.3	1.4	1.5	1.6	2.4	3.1	3.2	3.3	3.4	4.3	5.2	5.3	6.1	6.2	6.3	6.4	7.1	7.2	
		7.3	7.4	8.1	8.2	8.3	9.1															
A777	▪	1.5	1.6	3.4	4.1	4.2	4.3	5.2														
	•	1.1	1.2	1.3	1.4	2.1	2.2	2.3	3.1	3.2	3.3	5.1	5.3	6.1	6.2	6.3	6.4	7.1	7.2	7.3	7.4	
		9.1																				

A108	HSS	DIN 338	4XD	135°	ST		W			A188 134	L114 334
A147	HSS-E	DIN 338	4XD	130°			VA				
A777	HSS-E	DIN 338	4XD	135°	Bronze		N		NAS 907J	A295 135	

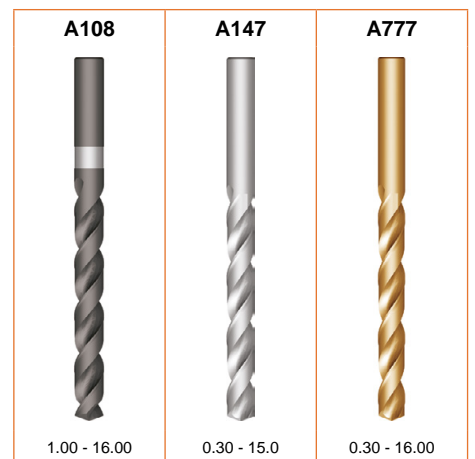
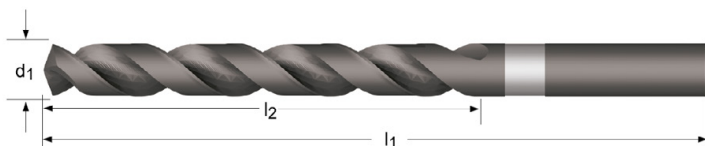

d_1 Ø _{h8} Inch	d_1 Ø _{h8} mm	d_1 decimal Inch	l_2 mm	l_1 mm	A108	A147	A777
	0.30	0.0118	3	19		A147.3	A777.3
	0.35	0.0138	4	19			A777.35
	0.40	0.0157	5	20		A147.4	A777.4
	0.45	0.0177	5	20			A777.45
	0.50	0.0197	6	22		A147.5	A777.5
	0.55	0.0217	7	24			A777.55

d_1 \varnothing_{h_8} Inch	d_1 \varnothing_{h_8} mm	d_1 decimal Inch	l_2 mm	l_1 mm	A108	A147	A777
	0.60	0.0236	7	24		A147.6	A777.6
	0.65	0.0256	8	26			A777.65
	0.70	0.0276	9	28		A147.7	A777.7
	0.80	0.0315	10	30		A147.8	A777.8
	0.90	0.0354	11	32		A147.9	A777.9
	0.95	0.0374	11	32			A777.95
	1.00	0.0394	12	34	A1081.0	A1471.0	A7771.0
	1.10	0.0433	14	36	A1081.1	A1471.1	A7771.1
	1.20	0.0472	16	38	A1081.2	A1471.2	A7771.2
	1.30	0.0512	16	38	A1081.3	A1471.3	A7771.3
	1.40	0.0551	18	40	A1081.4	A1471.4	A7771.4
	1.50	0.0591	18	40	A1081.5	A1471.5	A7771.5
1/16	1.59	0.0626	20	43	A1081/16	A1471/16	A7771/16
	1.60	0.0630	20	43	A1081.6	A1471.6	A7771.6
	1.70	0.0669	20	43	A1081.7	A1471.7	A7771.7
	1.80	0.0709	22	46	A1081.8	A1471.8	A7771.8
	1.90	0.0748	22	46	A1081.9	A1471.9	A7771.9
5/64	1.98	0.0780	24	49	A1085/64		A7775/64
	2.00	0.0787	24	49	A1082.0	A1472.0	A7772.0
	2.10	0.0827	24	49	A1082.1	A1472.1	A7772.1
	2.20	0.0866	27	53	A1082.2	A1472.2	A7772.2
	2.30	0.0906	27	53	A1082.3	A1472.3	A7772.3
3/32	2.38	0.0937	30	57	A1083/32	A1473/32	A7773/32
	2.40	0.0945	30	57	A1082.4	A1472.4	A7772.4
	2.50	0.0984	30	57	A1082.5	A1472.5	A7772.5
	2.60	0.1024	30	57	A1082.6	A1472.6	A7772.6
	2.70	0.1063	33	61	A1082.7	A1472.7	A7772.7
7/64	2.78	0.1094	33	61	A1087/64		A7777/64
	2.80	0.1102	33	61	A1082.8	A1472.8	A7772.8
	2.90	0.1142	33	61	A1082.9	A1472.9	A7772.9
	3.00	0.1181	33	61	A1083.0	A1473.0	A7773.0
	3.10	0.1220	36	65	A1083.1	A1473.1	A7773.1
1/8	3.18	0.1252	36	65	A1081/8	A1471/8	A7771/8
	3.20	0.1260	36	65	A1083.2	A1473.2	A7773.2
	3.30	0.1299	36	65	A1083.3	A1473.3	A7773.3
	3.40	0.1339	39	70	A1083.4	A1473.4	A7773.4
	3.50	0.1378	39	70	A1083.5	A1473.5	A7773.5
9/64	3.57	0.1406	39	70	A1089/64		A7779/64
	3.60	0.1417	39	70	A1083.6	A1473.6	A7773.6
	3.70	0.1457	39	70	A1083.7	A1473.7	A7773.7
	3.80	0.1496	43	75	A1083.8	A1473.8	A7773.8
	3.90	0.1535	43	75	A1083.9	A1473.9	A7773.9
5/32	3.97	0.1563	43	75	A1085/32	A1475/32	A7775/32
	4.00	0.1575	43	75	A1084.0	A1474.0	A7774.0
	4.10	0.1614	43	75	A1084.1	A1474.1	A7774.1
	4.20	0.1654	43	75	A1084.2	A1474.2	A7774.2
	4.30	0.1693	47	80	A1084.3	A1474.3	A7774.3
11/64	4.37	0.1720	47	80	A10811/64		A77711/64
	4.40	0.1732	47	80	A1084.4	A1474.4	A7774.4
	4.50	0.1772	47	80	A1084.5	A1474.5	A7774.5
	4.60	0.1811	47	80	A1084.6	A1474.6	A7774.6
	4.70	0.1850	47	80	A1084.7	A1474.7	A7774.7
3/16	4.76	0.1874	52	86	A1083/16	A1473/16	A7773/16
	4.80	0.1890	52	86	A1084.8	A1474.8	A7774.8
	4.90	0.1929	52	86	A1084.9	A1474.9	A7774.9
N10	4.92	0.1935	52	86	A108N10		
	5.00	0.1969	52	86	A1085.0	A1475.0	A7775.0
	5.10	0.2008	52	86	A1085.1	A1475.1	A7775.1
13/64	5.16	0.2031	52	86	A10813/64		A77713/64
	5.20	0.2047	52	86	A1085.2	A1475.2	A7775.2
	5.30	0.2087	52	86	A1085.3	A1475.3	A7775.3
	5.40	0.2126	57	93	A1085.4	A1475.4	A7775.4
	5.50	0.2165	57	93	A1085.5	A1475.5	A7775.5
7/32	5.56	0.2189	57	93	A1087/32		A7777/32
	5.60	0.2205	57	93	A1085.6	A1475.6	A7775.6
	5.70	0.2244	57	93	A1085.7	A1475.7	A7775.7
	5.80	0.2283	57	93	A1085.8	A1475.8	A7775.8
	5.90	0.2323	57	93	A1085.9	A1475.9	A7775.9
15/64	5.95	0.2343	57	93	A10815/64		A77715/64
	6.00	0.2362	57	93	A1086.0	A1476.0	A7776.0

d_1 $\varnothing h_8$ Inch	d_1 $\varnothing h_8$ mm	d_1 decimal Inch	l_2 mm	l_1 mm	A108	A147	A777
	6.10	0.2402	63	101	A1086.1	A1476.1	A7776.1
	6.20	0.2441	63	101	A1086.2	A1476.2	A7776.2
	6.30	0.2480	63	101	A1086.3	A1476.3	A7776.3
1/4	6.35	0.2500	63	101	A1081/4	A1471/4	A7771/4
	6.40	0.2520	63	101	A1086.4	A1476.4	A7776.4
	6.50	0.2559	63	101	A1086.5	A1476.5	A7776.5
	6.60	0.2598	63	101	A1086.6	A1476.6	A7776.6
	6.70	0.2638	63	101	A1086.7	A1476.7	A7776.7
17/64	6.75	0.2657	69	109	A10817/64		A77717/64
	6.80	0.2677	69	109	A1086.8	A1476.8	A7776.8
	6.90	0.2717	69	109	A1086.9	A1476.9	A7776.9
	7.00	0.2756	69	109	A1087.0	A1477.0	A7777.0
	7.10	0.2795	69	109	A1087.1	A1477.1	A7777.1
9/32	7.14	0.2811	69	109	A1089/32		A7779/32
	7.20	0.2835	69	109	A1087.2	A1477.2	A7777.2
	7.30	0.2874	69	109	A1087.3	A1477.3	A7777.3
	7.40	0.2913	69	109	A1087.4	A1477.4	A7777.4
	7.50	0.2953	69	109	A1087.5	A1477.5	A7777.5
19/64	7.54	0.2969	75	117	A10819/64		A77719/64
	7.60	0.2992	75	117	A1087.6	A1477.6	A7777.6
	7.70	0.3031	75	117	A1087.7	A1477.7	A7777.7
	7.80	0.3071	75	117	A1087.8	A1477.8	A7777.8
	7.90	0.3110	75	117	A1087.9	A1477.9	A7777.9
5/16	7.94	0.3126	75	117	A1085/16		A7775/16
	8.00	0.3150	75	117	A1088.0	A1478.0	A7778.0
	8.10	0.3189	75	117	A1088.1	A1478.1	A7778.1
	8.20	0.3228	75	117	A1088.2	A1478.2	A7778.2
	8.30	0.3268	75	117	A1088.3	A1478.3	A7778.3
21/64	8.33	0.3280	75	117	A10821/64		A77721/64
	8.40	0.3307	75	117	A1088.4	A1478.4	A7778.4
	8.50	0.3346	75	117	A1088.5	A1478.5	A7778.5
	8.60	0.3386	81	125	A1088.6	A1478.6	A7778.6
	8.70	0.3425	81	125	A1088.7	A1478.7	A7778.7
11/32	8.73	0.3437	81	125	A10811/32		A77711/32
	8.80	0.3465	81	125	A1088.8	A1478.8	A7778.8
	8.90	0.3504	81	125	A1088.9	A1478.9	A7778.9
	9.00	0.3543	81	125	A1089.0	A1479.0	A7779.0
	9.10	0.3583	81	125	A1089.1	A1479.1	A7779.1
23/64	9.13	0.3594	81	125	A10823/64		A77723/64
	9.20	0.3622	81	125	A1089.2	A1479.2	A7779.2
	9.30	0.3661	81	125	A1089.3	A1479.3	A7779.3
	9.40	0.3701	81	125	A1089.4	A1479.4	A7779.4
	9.50	0.3740	81	125	A1089.5	A1479.5	A7779.5
3/8	9.52	0.3748	87	133	A1083/8		A7773/8
	9.60	0.3780	87	133	A1089.6	A1479.6	A7779.6
	9.70	0.3819	87	133	A1089.7	A1479.7	A7779.7
	9.80	0.3858	87	133	A1089.8	A1479.8	A7779.8
	9.90	0.3898	87	133	A1089.9	A1479.9	A7779.9
25/64	9.92	0.3906	87	133	A10825/64		A77725/64
	10.00	0.3937	87	133	A10810.0	A14710.0	A77710.0
	10.10	0.3976	87	133			A77710.1
	10.20	0.4016	87	133	A10810.2	A14710.2	A77710.2
13/32	10.32	0.4063	87	133	A10813/32		A77713/32
	10.50	0.4134	87	133	A10810.5	A14710.5	A77710.5
27/64	10.72	0.4220	94	142	A10827/64		A77727/64
	10.80	0.4252	94	142	A10810.8		A77710.8
	11.00	0.4331	94	142	A10811.0	A14711.0	A77711.0
7/16	11.11	0.4374	94	142	A1087/16		A7777/16
	11.20	0.4409	94	142		A14711.2	A77711.2
	11.50	0.4528	94	142	A10811.5	A14711.5	A77711.5
29/64	11.51	0.4531	94	142	A10829/64		A77729/64
	11.80	0.4646	94	142	A10811.8		A77711.8
15/32	11.91	0.4689	101	151	A10815/32		A77715/32
	12.00	0.4724	101	151	A10812.0	A14712.0	A77712.0
	12.20	0.4803	101	151	A10812.2		A77712.2
31/64	12.30	0.4843	101	151	A10831/64		A77731/64
	12.50	0.4921	101	151	A10812.5	A14712.5	A77712.5
1/2	12.70	0.5000	101	151	A1081/2		A7771/2
	12.80	0.5039	101	151	A10812.8		A77712.8
	12.90	0.5079	101	151	A10812.9		

d_1 $\varnothing h_8$ Inch	d_1 $\varnothing h_8$ mm	d_1 decimal Inch	l_2 mm	l_1 mm	A108	A147	A777
	13.00	0.5118	101	151	A10813.0	A14713.0	A77713.0
	13.50	0.5315	108	160	A10813.5	A14713.5	A77713.5
	14.00	0.5512	108	160	A10814.0	A14714.0	A77714.0
	14.50	0.5709	114	169	A10814.5	A14714.5	A77714.5
	15.00	0.5906	114	169	A10815.0	A14715.0	A77715.0
	15.25	0.6004	120	178	A10815.25		
	15.50	0.6102	120	178	A10815.5		A77715.5
	16.00	0.6299	120	178	A10816.0		A77716.0

- A170**
- Punta con codolo cilindrico da 1/2 pollice
 - Spiralbohrer mit abgesetzten zylindrischen Schaft 12,7 Ø
 - Spiraalboor met 1/2" afgedraaide schacht
 - Foret queue dégaagée de 12,7 mm

A170	1.1	1.2	1.3	1.4	1.5	1.6	2.1	2.2	2.3	3.1	3.2	3.3	3.4	4.1	4.2	4.3	5.1	5.2	5.3	6.1	
	6.2	6.3	6.4	7.1	7.2	7.3	7.4	8.1	8.2	8.3	9.1										

A170 HSS DORMER 4XD 118° ST N

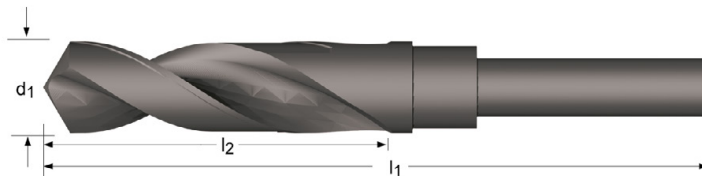

d_1 $\varnothing h_8$ Inch	d_1 $\varnothing h_8$ mm	d_1 decimal Inch	l_2 Inch	l_1 Inch	l_2 mm	l_1 mm	A170
	13.00	0.5118					A17013.0
33/64	13.10	0.5157	3.1/8	6"			A17033/64
17/32	13.49	0.5311	3.1/8	6"			A17017/32
	13.50	0.5315			83	156	A17013.5
35/64	13.89	0.5469	3.1/8	6"			A17035/64
	14.00	0.5512			83	156	A17014.0
9/16	14.29	0.5626	3.1/8	6"			A1709/16
	14.50	0.5709			83	156	A17014.5
37/64	14.68	0.5780	3.1/8	6"			A17037/64
	15.00	0.5906			83	156	A17015.0
19/32	15.08	0.5937	3.1/8	6"			A17019/32
39/64	15.48	0.6094	3.1/8	6"			A17039/64
	15.50	0.6102			83	156	A17015.5
5/8	15.88	0.6252	3.1/8	6"			A1705/8
	16.00	0.6299			84	157	A17016.0
41/64	16.27	0.6406	3.1/8	6"			A17041/64
	16.50	0.6496			84	157	A17016.5
21/32	16.67	0.6563	3.1/8	6"			A17021/32
	17.00	0.6693			84	157	A17017.0
43/64	17.07	0.6720	3.1/8	6"			A17043/64
11/16	17.46	0.6874	3.1/8	6"			A17011/16
	17.50	0.6890			84	157	A17017.5
45/64	17.86	0.7031	3.1/8	6"			A17045/64
	18.00	0.7087			84	157	A17018.0
23/32	18.26	0.7189	3.1/8	6"			A17023/32
	18.50	0.7283			84	157	A17018.5
47/64	18.65	0.7343	3.1/8	6"			A17047/64
	19.00	0.7480			84	157	A17019.0
3/4	19.05	0.7500	3.1/8	6"			A1703/4
49/64	19.45	0.7657	3"	6"			A17049/64
	19.50	0.7677			81	158	A17019.5
25/32	19.84	0.7811	3"	6"			A17025/32
	20.00	0.7874			81	158	A17020.0
51/64	20.24	0.7969	3"	6"			A17051/64
13/16	20.64	0.8126	3"	6"			A17013/16
	21.00	0.8268			82	158	A17021.0
53/64	21.03	0.8280	3"	6"			A17053/64
27/32	21.43	0.8437	3"	6"			A17027/32

d_1 $\varnothing h_8$ Inch	d_1 $\varnothing h_8$ mm	d_1 decimal Inch	l_2 Inch	l_1 Inch	l_2 mm	l_1 mm	A170
55/64	21.83	0.8594	3"	6"			A17055/64
	22.00	0.8661			82	158	A17022.0
7/8	22.22	0.8748	3"	6"			A1707/8
57/64	22.62	0.8906	3"	6"			A17057/64
	23.00	0.9055			82	158	A17023.0
29/32	23.02	0.9063	3"	6"			A17029/32
59/64	23.42	0.9220	3"	6"			A17059/64
15/16	23.81	0.9374	3"	6"			A17015/16
	24.00	0.9449			83	159	A17024.0
61/64	24.21	0.9531	3"	6"			A17061/64
31/32	24.61	0.9689	3"	6"			A17031/32
	25.00	0.9843			83	159	A17025.0
63/64	25.00	0.9843	3"	6"			A17063/64
1"	25.40	1.0000	3"	6"			A1701
1.1/32	26.19	1.0311	3"	6"			A1701.1/32
1.1/16	26.99	1.0626	3"	6"			A1701.1/16
1.7/64	28.18	1.1094	3"	6"			A1701.7/64
1.1/8	28.58	1.1252	3"	6"			A1701.1/8
1.9/64	28.97	1.1406	3"	6"			A1701.9/64
1.5/32	29.37	1.1563	3"	6"			A1701.5/32
1.3/16	30.16	1.1874	3"	6"			A1701.3/16
1.7/32	30.96	1.2189	3"	6"			A1701.7/32
1.1/4	31.75	1.2500	3"	6"			A1701.1/4
1.5/16	33.34	1.3126	3"	6"			A1701.5/16
1.3/8	34.93	1.3752	3"	6"			A1701.3/8
1.7/16	36.51	1.4374	3"	6"			A1701.7/16
1.1/2	38.10	1.5000	3"	6"			A1701.1/2

- A160**
- Punta serie corta con placchetta brasata in MD affilatura a 4 facce
 - Spiralbohrer mit gelöteter HM-Schneide
 - Korte spiraalboor met 4-vlaks geslepen HM punt
 - Foret court avec partie carbure rectifiée et brasée sur 4 facettes

A160	▪	3.1	3.2	3.3	3.4																
	•	1.1	1.2	1.3	1.4	1.5	1.6	2.1	2.2	2.3	4.1	4.2	4.3	5.1	5.2	5.3	6.1	6.2	6.3	6.4	7.1
		7.2	7.3	7.4	8.2	9.1															

A160

HSS
HM

DIN
338

4XD

118°

ST

N

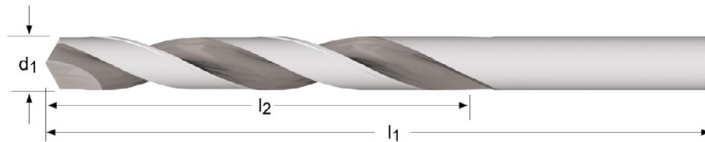

d_1 $\varnothing h_8$ mm	d_1 decimal Inch	l_2 mm	l_1 mm	A160
4.00	0.1575	43	75	A1604.0
4.50	0.1772	47	80	A1604.5
5.00	0.1969	52	86	A1605.0
5.50	0.2165	57	93	A1605.5
6.00	0.2362	57	93	A1606.0
6.50	0.2559	63	101	A1606.5
6.80	0.2677	69	109	A1606.8
7.00	0.2756	69	109	A1607.0
7.50	0.2953	69	109	A1607.5
8.00	0.3150	75	117	A1608.0
8.50	0.3346	75	117	A1608.5
9.00	0.3543	81	125	A1609.0
9.50	0.3740	81	125	A1609.5
10.00	0.3937	87	133	A16010.0
10.20	0.4016	87	133	A16010.2
10.50	0.4134	87	133	A16010.5
11.00	0.4331	94	142	A16011.0
11.50	0.4528	94	142	A16011.5
12.00	0.4724	101	151	A16012.0
13.00	0.5118	101	151	A16013.0
14.00	0.5512	108	160	A16014.0
15.00	0.5906	114	169	A16015.0
16.00	0.6299	120	178	A16016.0

A510

- Punta ADX serie corta
- ADX Spiralbohrer
- ADX spiraalboor
- Foret court ADX

A510	▪	1.1	1.2	1.3	1.4	1.5	2.1	2.2	3.1	3.2	3.3	3.4	6.2	6.3	7.2	7.3	7.4	8.1	8.2	8.3
	•	1.6	2.3	4.1	4.2	4.3	5.1	5.2	5.3	6.1	6.4	7.1								

A510 HSS DIN 338 4XD 130° TiN



d_1 $\varnothing h_8$ Inch	d_1 $\varnothing h_8$ mm	d_1 decimal Inch	l_2 mm	l_1 mm	A510
	3.00	0.1181	33	61	A5103.0
	3.10	0.1220	36	65	A5103.1
1/8	3.18	0.1252	36	65	A5101/8
	3.20	0.1260	36	65	A5103.2
	3.30	0.1299	36	65	A5103.3
	3.40	0.1339	39	70	A5103.4
	3.50	0.1378	39	70	A5103.5
9/64	3.57	0.1406	39	70	A5109/64
	3.60	0.1417	39	70	A5103.6
	3.70	0.1457	39	70	A5103.7
	3.80	0.1496	43	75	A5103.8
	3.90	0.1535	43	75	A5103.9
5/32	3.97	0.1563	43	75	A5105/32
	4.00	0.1575	43	75	A5104.0
	4.10	0.1614	43	75	A5104.1
	4.20	0.1654	43	75	A5104.2
	4.30	0.1693	47	80	A5104.3
11/64	4.37	0.1720	47	80	A51011/64
	4.40	0.1732	47	80	A5104.4
	4.50	0.1772	47	80	A5104.5
	4.60	0.1811	47	80	A5104.6
	4.70	0.1850	47	80	A5104.7
3/16	4.76	0.1874	52	86	A5103/16
	4.80	0.1890	52	86	A5104.8
	4.90	0.1929	52	86	A5104.9
	5.00	0.1969	52	86	A5105.0
	5.10	0.2008	52	86	A5105.1
13/64	5.16	0.2031	52	86	A51013/64
	5.20	0.2047	52	86	A5105.2
	5.30	0.2087	52	86	A5105.3
	5.40	0.2126	57	93	A5105.4
	5.50	0.2165	57	93	A5105.5
7/32	5.56	0.2189	57	93	A5107/32
	5.60	0.2205	57	93	A5105.6
	5.70	0.2244	57	93	A5105.7
	5.80	0.2283	57	93	A5105.8

d_1 $\varnothing h_8$ Inch	d_1 $\varnothing h_8$ mm	d_1 decimal Inch	l_2 mm	l_1 mm	A510
15/64	5.90	0.2323	57	93	A5105.9
	5.95	0.2343	57	93	A51015/64
	6.00	0.2362	57	93	A5106.0
	6.10	0.2402	63	101	A5106.1
1/4	6.20	0.2441	63	101	A5106.2
	6.30	0.2480	63	101	A5106.3
	6.35	0.2500	63	101	A5101/4
	6.40	0.2520	63	101	A5106.4
	6.50	0.2559	63	101	A5106.5
	6.60	0.2598	63	101	A5106.6
	6.70	0.2638	63	101	A5106.7
17/64	6.75	0.2657	69	109	A51017/64
	6.80	0.2677	69	109	A5106.8
	6.90	0.2717	69	109	A5106.9
	7.00	0.2756	69	109	A5107.0
	7.10	0.2795	69	109	A5107.1
9/32	7.14	0.2811	69	109	A5109/32
	7.20	0.2835	69	109	A5107.2
	7.30	0.2874	69	109	A5107.3
	7.40	0.2913	69	109	A5107.4
	7.50	0.2953	69	109	A5107.5
19/64	7.54	0.2969	75	117	A51019/64
	7.60	0.2992	75	117	A5107.6
	7.70	0.3031	75	117	A5107.7
	7.80	0.3071	75	117	A5107.8
	7.90	0.3110	75	117	A5107.9
5/16	7.94	0.3126	75	117	A5105/16
	8.00	0.3150	75	117	A5108.0
	8.10	0.3189	75	117	A5108.1
	8.20	0.3228	75	117	A5108.2
	8.30	0.3268	75	117	A5108.3
21/64	8.33	0.3280	75	117	A51021/64
	8.40	0.3307	75	117	A5108.4
	8.50	0.3346	75	117	A5108.5
	8.60	0.3386	81	125	A5108.6
	8.70	0.3425	81	125	A5108.7
11/32	8.73	0.3437	81	125	A51011/32
	8.80	0.3465	81	125	A5108.8
	8.90	0.3504	81	125	A5108.9
	9.00	0.3543	81	125	A5109.0
	9.10	0.3583	81	125	A5109.1
23/64	9.13	0.3594	81	125	A51023/64
	9.20	0.3622	81	125	A5109.2
	9.30	0.3661	81	125	A5109.3
	9.40	0.3701	81	125	A5109.4
	9.50	0.3740	81	125	A5109.5
3/8	9.52	0.3748	87	133	A5103/8
	9.60	0.3780	87	133	A5109.6
	9.70	0.3819	87	133	A5109.7
	9.80	0.3858	87	133	A5109.8
	9.90	0.3898	87	133	A5109.9
25/64	9.92	0.3906	87	133	A51025/64
	10.00	0.3937	87	133	A51010.0
	10.10	0.3976	87	133	A51010.1
	10.20	0.4016	87	133	A51010.2
	10.30	0.4055	87	133	A51010.3
13/32	10.32	0.4063	87	133	A51013/32
	10.40	0.4094	87	133	A51010.4
	10.50	0.4134	87	133	A51010.5
	10.60	0.4173	87	133	A51010.6
	10.70	0.4213	94	142	A51010.7
27/64	10.72	0.4220	94	142	A51027/64
	10.80	0.4252	94	142	A51010.8
	10.90	0.4291	94	142	A51010.9
	11.00	0.4331	94	142	A51011.0
	11.10	0.4370	94	142	A51011.1
7/16	11.11	0.4374	94	142	A5107/16
	11.20	0.4409	94	142	A51011.2
	11.30	0.4449	94	142	A51011.3
	11.40	0.4488	94	142	A51011.4

d_1 $\varnothing h_8$ Inch	d_1 $\varnothing h_8$ mm	d_1 decimal Inch	l_2 mm	l_1 mm	A510
29/64	11.50	0.4528	94	142	A51011.5
	11.51	0.4531	94	142	A51029/64
	11.60	0.4567	94	142	A51011.6
	11.70	0.4606	94	142	A51011.7
	11.80	0.4646	94	142	A51011.8
15/32	11.90	0.4685	101	151	A51011.9
	11.91	0.4689	101	151	A51015/32
	12.00	0.4724	101	151	A51012.0
	12.10	0.4764	101	151	A51012.1
	12.20	0.4803	101	151	A51012.2
31/64	12.30	0.4843	101	151	A51012.3
	12.30	0.4843	101	151	A51031/64
	12.40	0.4882	101	151	A51012.4
	12.50	0.4921	101	151	A51012.5
	12.60	0.4961	101	151	A51012.6
1/2	12.70	0.5000	101	151	A51012.7
	12.70	0.5000	101	151	A5101/2
	12.80	0.5039	101	151	A51012.8
	12.90	0.5079	101	151	A51012.9
	13.00	0.5118	101	151	A51013.0
	14.00	0.5512	108	160	A51014.0

- A553**
- Punta ADX con fori di lubrificazione
 - ADX Spiralbohrer, mit Kühlkanal
 - ADX Spiraalboor, met koelkanalen
 - Foret ADX - à trous d'huile

A553	▪	1.1	1.2	1.3	1.4	1.5	1.6	2.1	2.2	3.1	3.2	3.3	3.4	4.1	6.2	6.3	7.2	7.3	7.4	8.1
	•	2.3	4.2	4.3	5.1	5.2	5.3	6.1	6.4	7.1										

A553 HSS-E



5XD

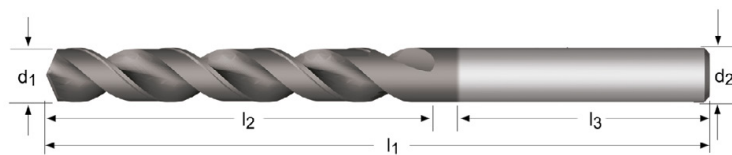

A553



ADX

5.00 - 20.00

d ₁ Øh ₈ mm	d ₁ decimal Inch	l ₂ mm	l ₁ mm	l ₃ mm	d ₂ Øh ₆ mm	A553
5.00	0.1969	36	79	36	6	A5535.0
5.20	0.2047	38	79	36	6	A5535.2
5.50	0.2165	40	79	36	6	A5535.5
6.00	0.2362	43	79	36	6	A5536.0
6.30	0.2480	46	87	36	8	A5536.3
6.50	0.2559	47	87	36	8	A5536.5
6.80	0.2677	48	87	36	8	A5536.8
6.90	0.2717	48	87	36	8	A5536.9
7.00	0.2756	48	87	36	8	A5537.0
7.40	0.2913	54	94	36	8	A5537.4
7.50	0.2953	54	94	36	8	A5537.5
8.00	0.3150	58	94	36	8	A5538.0
8.50	0.3346	75	130	40	10	A5538.5
8.70	0.3425	75	130	40	10	A5538.7
9.00	0.3543	75	130	40	10	A5539.0
9.50	0.3740	75	130	40	10	A5539.5
10.00	0.3937	75	130	40	10	A55310.0
10.20	0.4016	87	150	45	12	A55310.2
10.30	0.4055	87	150	45	12	A55310.3
10.50	0.4134	87	150	45	12	A55310.5
11.00	0.4331	94	150	45	12	A55311.0
11.30	0.4449	94	150	45	12	A55311.3
11.50	0.4528	94	150	45	12	A55311.5
12.00	0.4724	94	150	45	12	A55312.0
12.50	0.4921	101	160	45	14	A55312.5
13.00	0.5118	101	160	45	14	A55313.0
13.50	0.5315	101	160	45	14	A55313.5
14.00	0.5512	101	160	45	14	A55314.0
14.25	0.5610	108	170	48	16	A55314.25
14.50	0.5709	108	170	48	16	A55314.5
15.00	0.5906	108	170	48	16	A55315.0
15.25	0.6004	108	170	48	16	A55315.25
15.50	0.6102	108	170	48	16	A55315.5
16.00	0.6299	108	170	48	16	A55316.0
16.50	0.6496	125	190	48	18	A55316.5
17.00	0.6693	125	190	48	18	A55317.0

d_1 $\varnothing h_8$ mm	d_1 decimal Inch	l_2 mm	l_1 mm	l_3 mm	d_2 $\varnothing h_6$ mm	A553
17.50	0.6890	130	190	48	18	A55317.5
17.75	0.6988	130	190	48	18	A55317.75
18.00	0.7087	130	190	48	18	A55318.0
19.00	0.7480	135	200	50	20	A55319.0
19.25	0.7579	140	200	50	20	A55319.25
20.00	0.7874	140	200	50	20	A55320.0

A900 • Punte PFX serie corta
• PFX - Tieflochspiralbohrer

A901 • PFX Diepgatspiraalboor
• Foret PFX court

A900	▪	1.1	1.2	1.3	1.4	1.5	1.6	2.1	2.2	2.3	4.1	4.2	4.3	5.1	5.2	5.3	7.2
	•	3.1	3.2	3.3	3.4	6.1	6.2	6.3	6.4	7.1	7.3	7.4	8.1	8.2			
A901	▪	1.1	1.2	1.3	1.4	1.5	1.6	2.1	2.2	2.3	3.1	3.2	3.3	3.4	7.4		
	•	4.1	4.2	4.3	5.1	5.2	5.3	6.3	6.4								

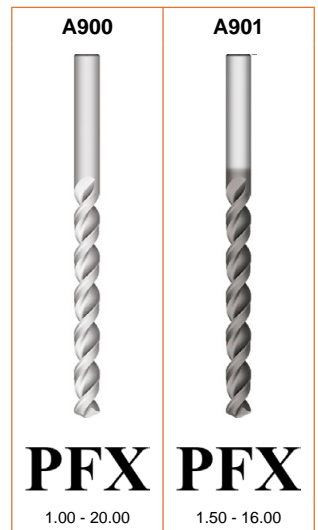
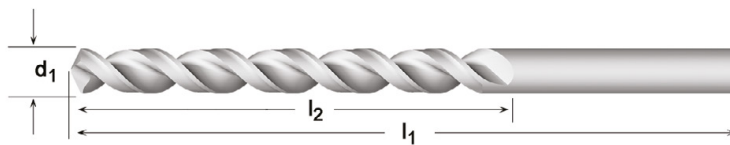
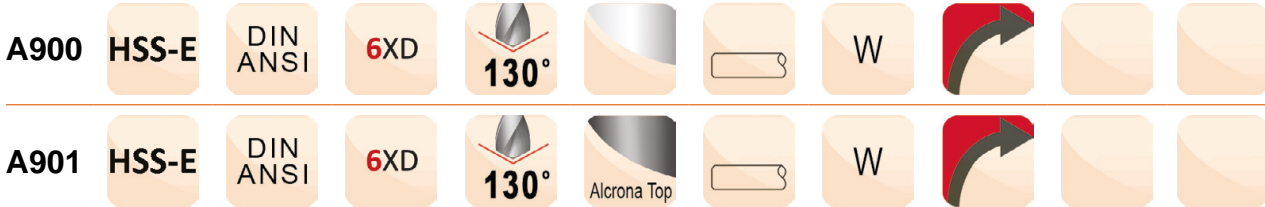

d_1 \varnothing_{h_8} Inch	d_1 \varnothing_{h_8} mm	d_1 decimal Inch	l_2 mm	l_1 mm	A900	A901
	1.00	0.0394	12	34	A9001.0	
	1.10	0.0433	14	36	A9001.1	
3/64	1.19	0.0469	19	44	A9003/64	
	1.20	0.0472	16	38	A9001.2	
	1.25	0.0492	16	36	A9001.25	
	1.30	0.0512	16	38	A9001.3	
	1.40	0.0551	18	40	A9001.4	
	1.50	0.0591	18	40	A9001.5	A9011.5
	1.55	0.0610	20	43	A9001.55	A9011.55
1/16	1.59	0.0626	22	48	A9001/16	A9011/16
	1.60	0.0630	20	43	A9001.6	A9011.6
	1.70	0.0669	20	43	A9001.7	
	1.75	0.0689	22	46	A9001.75	A9011.75
	1.80	0.0709	22	46	A9001.8	A9011.8
	1.90	0.0748	22	46	A9001.9	A9011.9
5/64	1.98	0.0780	25	51	A9005/64	A9015/64
	2.00	0.0787	24	49	A9002.0	A9012.0
	2.10	0.0827	24	49	A9002.1	A9012.1
	2.15	0.0846	27	53	A9002.15	A9012.15
	2.20	0.0866	27	53	A9002.2	
	2.30	0.0906	27	53	A9002.3	
3/32	2.38	0.0937	32	57	A9003/32	A9013/32
	2.40	0.0945	30	57	A9002.4	A9012.4
	2.50	0.0984	30	57	A9002.5	A9012.5
	2.60	0.1024	30	57	A9002.6	A9012.6
	2.70	0.1063	33	61	A9002.7	A9012.7
7/64	2.78	0.1094	38	67	A9007/64	A9017/64
	2.80	0.1102	33	61	A9002.8	

d_1 $\varnothing h_8$ Inch	d_1 $\varnothing h_8$ mm	d_1 decimal Inch	l_2 mm	l_1 mm	A900	A901
	2.90	0.1142	33	61	A9002.9	A9012.9
	3.00	0.1181	33	61	A9003.0	A9013.0
	3.10	0.1220	36	65	A9003.1	A9013.1
1/8	3.18	0.1252	41	70	A9001/8	A9011/8
	3.20	0.1260	36	65	A9003.2	A9013.2
	3.30	0.1299	36	65	A9003.3	A9013.3
	3.40	0.1339	39	70	A9003.4	A9013.4
	3.50	0.1378	39	70	A9003.5	A9013.5
9/64	3.57	0.1406	44	73	A9009/64	A9019/64
	3.60	0.1417	39	70	A9003.6	A9013.6
	3.70	0.1457	39	70	A9003.7	A9013.7
	3.80	0.1496	43	75	A9003.8	A9013.8
	3.90	0.1535	43	75	A9003.9	A9013.9
5/32	3.97	0.1563	51	79	A9005/32	A9015/32
	4.00	0.1575	43	75	A9004.0	A9014.0
	4.10	0.1614	43	75	A9004.1	A9014.1
	4.20	0.1654	43	75	A9004.2	A9014.2
	4.30	0.1693	47	80	A9004.3	A9014.3
11/64	4.37	0.1720	54	83	A90011/64	A90111/64
	4.40	0.1732	47	80	A9004.4	A9014.4
	4.50	0.1772	47	80	A9004.5	A9014.5
	4.60	0.1811	47	80	A9004.6	A9014.6
	4.70	0.1850	47	80	A9004.7	A9014.7
3/16	4.76	0.1874	59	89	A9003/16	A9013/16
	4.80	0.1890	52	86	A9004.8	A9014.8
	4.90	0.1929	52	86	A9004.9	A9014.9
	5.00	0.1969	52	86	A9005.0	A9015.0
	5.10	0.2008	52	86	A9005.1	A9015.1
13/64	5.16	0.2031	62	92	A90013/64	A90113/64
	5.20	0.2047	52	86	A9005.2	A9015.2
	5.30	0.2087	52	86	A9005.3	A9015.3
	5.40	0.2126	57	93	A9005.4	A9015.4
	5.50	0.2165	57	93	A9005.5	A9015.5
7/32	5.56	0.2189	64	95	A9007/32	A9017/32
	5.60	0.2205	57	93	A9005.6	A9015.6
	5.70	0.2244	57	93	A9005.7	A9015.7
	5.80	0.2283	57	93	A9005.8	A9015.8
	5.90	0.2323	57	93	A9005.9	A9015.9
15/64	5.95	0.2343	67	98	A90015/64	A90115/64
	6.00	0.2362	57	93	A9006.0	A9016.0
	6.10	0.2402	63	101	A9006.1	A9016.1
	6.20	0.2441	63	101	A9006.2	A9016.2
	6.30	0.2480	63	101	A9006.3	A9016.3
1/4	6.35	0.2500	70	102	A9001/4	A9011/4
	6.40	0.2520	63	101	A9006.4	A9016.4
	6.50	0.2559	63	101	A9006.5	A9016.5
	6.60	0.2598	63	101	A9006.6	A9016.6
	6.70	0.2638	63	101	A9006.7	A9016.7
17/64	6.75	0.2657	73	105	A90017/64	A90117/64
	6.80	0.2677	69	109	A9006.8	A9016.8
	6.90	0.2717	69	109	A9006.9	A9016.9
	7.00	0.2756	69	109	A9007.0	A9017.0
	7.10	0.2795	69	109	A9007.1	A9017.1
9/32	7.14	0.2811	75	108	A9009/32	A9019/32
	7.20	0.2835	69	109	A9007.2	A9017.2
	7.30	0.2874	69	109	A9007.3	A9017.3
	7.40	0.2913	69	109	A9007.4	A9017.4
	7.50	0.2953	69	109	A9007.5	A9017.5
19/64	7.54	0.2969	78	111	A90019/64	A90119/64
	7.60	0.2992	75	117	A9007.6	A9017.6
	7.70	0.3031	75	117	A9007.7	A9017.7
	7.80	0.3071	75	117	A9007.8	A9017.8
	7.90	0.3110	75	117	A9007.9	A9017.9
5/16	7.94	0.3126	81	114	A9005/16	A9015/16
	8.00	0.3150	75	117	A9008.0	A9018.0
	8.10	0.3189	75	117	A9008.1	A9018.1
	8.20	0.3228	75	117	A9008.2	A9018.2
	8.30	0.3268	75	117	A9008.3	A9018.3
21/64	8.33	0.3280	84	117	A90021/64	A90121/64
	8.40	0.3307	75	117	A9008.4	A9018.4

d_1 \varnothing_{h_8} Inch	d_1 \varnothing_{h_8} mm	d_1 decimal Inch	l_2 mm	l_1 mm	A900	A901
	8.50	0.3346	75	117	A9008.5	A9018.5
	8.60	0.3386	81	125	A9008.6	A9018.6
	8.70	0.3425	81	125	A9008.7	A9018.7
11/32	8.73	0.3437	87	121	A90011/32	A90111/32
	8.80	0.3465	81	125	A9008.8	A9018.8
	8.90	0.3504	81	125	A9008.9	A9018.9
	9.00	0.3543	81	125	A9009.0	A9019.0
	9.10	0.3583	81	125	A9009.1	A9019.1
23/64	9.13	0.3594	89	124	A90023/64	A90123/64
	9.20	0.3622	81	125	A9009.2	A9019.2
	9.30	0.3661	81	125	A9009.3	A9019.3
	9.40	0.3701	81	125	A9009.4	A9019.4
	9.50	0.3740	81	125	A9009.5	A9019.5
3/8	9.52	0.3748	92	127	A9003/8	A9013/8
	9.60	0.3780	87	133	A9009.6	A9019.6
	9.70	0.3819	87	133	A9009.7	A9019.7
	9.80	0.3858	87	133	A9009.8	A9019.8
	9.90	0.3898	87	133	A9009.9	A9019.9
25/64	9.92	0.3906	95	130	A90025/64	A90125/64
	10.00	0.3937	87	133	A90010.0	A90110.0
	10.20	0.4016	87	133	A90010.2	A90110.2
	10.30	0.4055	87	133	A90010.3	A90110.3
13/32	10.32	0.4063	98	133	A90013/32	A90113/32
	10.40	0.4094	87	133	A90010.4	A90110.4
	10.50	0.4134	87	133	A90010.5	A90110.5
27/64	10.72	0.4220	100	137	A90027/64	A90127/64
	10.80	0.4252	94	142	A90010.8	A90110.8
	11.00	0.4331	94	142	A90011.0	A90111.0
7/16	11.11	0.4374	103	140	A9007/16	A9017/16
	11.50	0.4528	94	142	A90011.5	A90111.5
29/64	11.51	0.4531	106	143	A90029/64	A90129/64
	11.80	0.4646	94	142	A90011.8	A90111.8
15/32	11.91	0.4689	110	146	A90015/32	A90115/32
	12.00	0.4724	101	151	A90012.0	A90112.0
31/64	12.30	0.4843	111	149	A90031/64	A90131/64
	12.50	0.4921	101	151	A90012.5	A90112.5
1/2	12.70	0.5000	101	151	A9001/2	A9011/2
	13.00	0.5118	101	151	A90013.0	A90113.0
33/64	13.10	0.5157	122	168	A90033/64	A90133/64
	13.50	0.5315	108	160	A90013.5	A90113.5
35/64	13.89	0.5469	122	168	A90035/64	A90135/64
	14.00	0.5512	108	160	A90014.0	A90114.0
9/16	14.29	0.5626	122	168	A9009/16	A9019/16
	14.50	0.5709	114	169	A90014.5	A90114.5
37/64	14.68	0.5780	122	168	A90037/64	A90137/64
	15.00	0.5906	114	169	A90015.0	A90115.0
19/32	15.08	0.5937	132	181	A90019/32	A90119/32
39/64	15.48	0.6094	132	181	A90039/64	A90139/64
	15.50	0.6102	120	178	A90015.5	A90115.5
5/8	15.88	0.6252	132	181	A9005/8	A9015/8
	16.00	0.6299	120	178	A90016.0	A90116.0
41/64	16.27	0.6406	132	181	A90041/64	
	16.50	0.6496	125	184	A90016.5	
21/32	16.67	0.6563	132	181	A90021/32	
	17.00	0.6693	125	184	A90017.0	
43/64	17.07	0.6720	143	194	A90043/64	
11/16	17.46	0.6874	143	194	A90011/16	
	17.50	0.6890	130	191	A90017.5	
45/64	17.86	0.7031	130	191	A90045/64	
	18.00	0.7087	130	191	A90018.0	
23/32	18.26	0.7189	130	191	A90023/32	
	18.50	0.7283	135	198	A90018.5	
47/64	18.65	0.7343	135	198	A90047/64	
	19.00	0.7480	135	198	A90019.0	
3/4	19.05	0.7500	135	198	A9003/4	
49/64	19.45	0.7657	135	198	A90049/64	
	19.50	0.7677	140	205	A90019.5	
25/32	19.84	0.7811	140	205	A90025/32	
	20.00	0.7874	140	205	A90020.0	

- A243**
- Punta per aeronautica
 - Bohrer für die Flugzeugindustrie
- A244**
- Lange spiraalboor voor de luchtvaartindustrie
 - Foret aéronautique à queue cylindrique rallongée

Lunghezza totale 150 mm
 150 mm Gesamtlänge
 150 mm totale lengte
 Longueur totale de 150 mm

A243; A244	▪	1.5	1.6	2.2	2.3	3.4	4.1	4.2	4.3	5.1	6.4	7.4
	•	1.3	1.4	2.1	3.1	3.2	3.3	5.2	5.3	6.3	9.1	

A243	HSS	NAS 907	4XD	135°			N			
A244	HSS	NAS 907	4XD	118°			N			

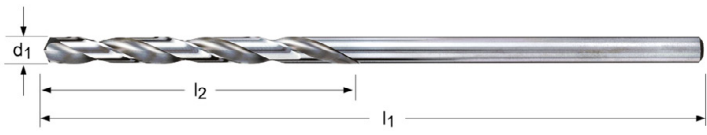

d_1 \varnothing Inch	d_1 decimal Inch	l_2 Inch	l_1 Inch	A243	A244
3/32	0.0938	1.1/4	6"	A2433/32X6	
40	0.0980	1.3/8	6"	A243N40X6	
1/8	0.1250	1.5/8	6"	A2431/8X6	A2441/8X6
30	0.1285	1.5/8	6"	A243N30X6	
5/32	0.1563	2"	6"	A2435/32X6	A2445/32X6
21	0.1590	2.1/8	6"	A243N21X6	
20	0.1610	2.1/8	6"	A243N20X6	
3/16	0.1875	2.5/16	6"	A2433/16X6	A2443/16X6
11	0.1910	2.5/16	6"	A243N11X6	
10	0.1935	2.7/16	6"	A243N10X6	
1/4	0.2500	2.3/4	6"	A2431/4X6	A2441/4X6

A110

- Punta serie lunga
- Lange Spiralbohrer
- Spiraalboor, lang
- Foret série longue

Senza trattamento sotto 1,0 mm , 1/16"
 Blank bis 1 mm Ø
 Blank beneden 1,0mm, 3/16"
 Brillant au dessous de 1,0 mm, 1/16

A110	•	1.1	1.2	1.3	1.4	1.5	1.6	2.1	2.2	2.3	3.1	3.2	3.3	3.4	4.1	4.2	4.3	5.1	5.2	5.3	6.1	
		6.2	6.3	6.4	7.1	7.2	7.3	7.4	8.1	8.2	8.3	9.1										

A110 **HSS** **DIN 340** **6XD** **118°** ST     

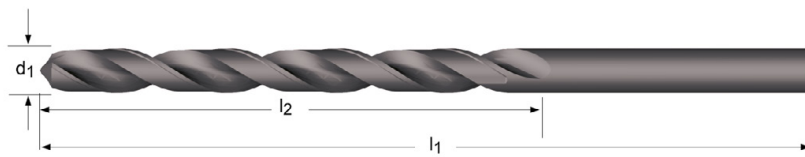

d_1 $\varnothing h_8$ Inch	d_1 $\varnothing h_8$ mm	d_1 decimal Inch	l_2 mm	l_1 mm	A110
	0.50	0.0197	12	32	A110.5
	0.60	0.0236	15	35	A110.6
	0.70	0.0276	21	42	A110.7
1/32	0.79	0.0311	25	46	A1101/32
	0.80	0.0315	25	46	A110.8
	0.90	0.0354	29	51	A110.9
	1.00	0.0394	33	56	A1101.0
	1.10	0.0433	37	60	A1101.1
	1.20	0.0472	41	65	A1101.2
	1.30	0.0512	41	65	A1101.3
	1.40	0.0551	45	70	A1101.4
	1.50	0.0591	45	70	A1101.5
1/16	1.59	0.0626	50	76	A1101/16
	1.60	0.0630	50	76	A1101.6
	1.70	0.0669	50	76	A1101.7
	1.75	0.0689	53	80	A1101.75
	1.80	0.0709	53	80	A1101.8
	1.90	0.0748	53	80	A1101.9
5/64	1.98	0.0780	56	85	A1105/64
	2.00	0.0787	56	85	A1102.0
	2.05	0.0807	56	85	A1102.05
	2.10	0.0827	56	85	A1102.1
	2.20	0.0866	59	90	A1102.2
	2.25	0.0886	59	90	A1102.25
	2.30	0.0906	59	90	A1102.3
3/32	2.38	0.0937	62	95	A1103/32
	2.40	0.0945	62	95	A1102.4
	2.50	0.0984	62	95	A1102.5
	2.60	0.1024	62	95	A1102.6
	2.70	0.1063	66	100	A1102.7
7/64	2.78	0.1094	66	100	A1107/64
	2.80	0.1102	66	100	A1102.8
	2.90	0.1142	66	100	A1102.9
	3.00	0.1181	66	100	A1103.0
	3.10	0.1220	69	106	A1103.1
1/8	3.18	0.1252	69	106	A1101/8
	3.20	0.1260	69	106	A1103.2
	3.25	0.1280	69	106	A1103.25

d₁ Øh₈ Inch	d₁ Øh₈ mm	d₁ decimal Inch	l₂ mm	l₁ mm	A110
	3.30	0.1299	69	106	A1103.3
	3.40	0.1339	73	112	A1103.4
	3.50	0.1378	73	112	A1103.5
9/64	3.57	0.1406	73	112	A1109/64
	3.60	0.1417	73	112	A1103.6
	3.70	0.1457	73	112	A1103.7
	3.75	0.1476	73	112	A1103.75
	3.80	0.1496	78	119	A1103.8
	3.90	0.1535	78	119	A1103.9
5/32	3.97	0.1563	78	119	A1105/32
	4.00	0.1575	78	119	A1104.0
	4.10	0.1614	78	119	A1104.1
	4.20	0.1654	78	119	A1104.2
	4.25	0.1673	78	119	A1104.25
	4.30	0.1693	82	126	A1104.3
11/64	4.37	0.1720	82	126	A11011/64
	4.40	0.1732	82	126	A1104.4
	4.50	0.1772	82	126	A1104.5
	4.60	0.1811	82	126	A1104.6
	4.70	0.1850	82	126	A1104.7
	4.75	0.1870	82	126	A1104.75
3/16	4.76	0.1874	87	132	A1103/16
	4.80	0.1890	87	132	A1104.8
	4.90	0.1929	87	132	A1104.9
	5.00	0.1969	87	132	A1105.0
	5.10	0.2008	87	132	A1105.1
13/64	5.16	0.2031	87	132	A11013/64
	5.20	0.2047	87	132	A1105.2
	5.25	0.2067	87	132	A1105.25
	5.30	0.2087	87	132	A1105.3
	5.40	0.2126	91	139	A1105.4
	5.50	0.2165	91	139	A1105.5
7/32	5.56	0.2189	91	139	A1107/32
	5.60	0.2205	91	139	A1105.6
	5.70	0.2244	91	139	A1105.7
	5.75	0.2264	91	139	A1105.75
	5.80	0.2283	91	139	A1105.8
	5.90	0.2323	91	139	A1105.9
15/64	5.95	0.2343	91	139	A11015/64
	6.00	0.2362	91	139	A1106.0
	6.10	0.2402	97	148	A1106.1
	6.20	0.2441	97	148	A1106.2
	6.25	0.2461	97	148	A1106.25
	6.30	0.2480	97	148	A1106.3
1/4	6.35	0.2500	97	148	A1101/4
	6.40	0.2520	97	148	A1106.4
	6.50	0.2559	97	148	A1106.5
	6.60	0.2598	97	148	A1106.6
	6.70	0.2638	97	148	A1106.7
17/64	6.75	0.2657	102	156	A11017/64
	6.75	0.2657	102	156	A1106.75
	6.80	0.2677	102	156	A1106.8
	6.90	0.2717	102	156	A1106.9
	7.00	0.2756	102	156	A1107.0
	7.10	0.2795	102	156	A1107.1
9/32	7.14	0.2811	102	156	A1109/32
	7.20	0.2835	102	156	A1107.2
	7.25	0.2854	102	156	A1107.25
	7.30	0.2874	102	156	A1107.3
	7.40	0.2913	102	156	A1107.4
	7.50	0.2953	102	156	A1107.5
	7.60	0.2992	109	165	A1107.6
	7.70	0.3031	109	165	A1107.7
	7.75	0.3051	109	165	A1107.75
	7.80	0.3071	109	165	A1107.8
	7.90	0.3110	109	165	A1107.9
5/16	7.94	0.3126	109	165	A1105/16
	8.00	0.3150	109	165	A1108.0
	8.10	0.3189	109	165	A1108.1
	8.20	0.3228	109	165	A1108.2

d_1 $\varnothing h_8$ Inch	d_1 $\varnothing h_8$ mm	d_1 decimal Inch	l_2 mm	l_1 mm	A110
	8.25	0.3248	109	165	A1108.25
	8.30	0.3268	109	165	A1108.3
	8.40	0.3307	109	165	A1108.4
	8.50	0.3346	109	165	A1108.5
	8.60	0.3386	115	175	A1108.6
	8.70	0.3425	115	175	A1108.7
11/32	8.73	0.3437	115	175	A11011/32
	8.75	0.3445	115	175	A1108.75
	8.80	0.3465	115	175	A1108.8
	8.90	0.3504	115	175	A1108.9
	9.00	0.3543	115	175	A1109.0
	9.10	0.3583	115	175	A1109.1
	9.20	0.3622	115	175	A1109.2
	9.25	0.3642	115	175	A1109.25
	9.30	0.3661	115	175	A1109.3
	9.40	0.3701	115	175	A1109.4
	9.50	0.3740	115	175	A1109.5
3/8	9.52	0.3748	121	184	A1103/8
	9.60	0.3780	121	184	A1109.6
	9.70	0.3819	121	184	A1109.7
	9.75	0.3839	121	184	A1109.75
	9.80	0.3858	121	184	A1109.8
	9.90	0.3898	121	184	A1109.9
	10.00	0.3937	121	184	A11010.0
	10.10	0.3976	121	184	A11010.1
	10.20	0.4016	121	184	A11010.2
	10.25	0.4035	121	184	A11010.25
	10.30	0.4055	121	184	A11010.3
13/32	10.32	0.4063	121	184	A11013/32
	10.50	0.4134	121	184	A11010.5
	10.75	0.4232	128	195	A11010.75
	10.80	0.4252	128	195	A11010.8
	11.00	0.4331	128	195	A11011.0
7/16	11.11	0.4374	128	195	A1107/16
	11.25	0.4429	128	195	A11011.25
	11.40	0.4488	128	195	A11011.4
	11.50	0.4528	128	195	A11011.5
	11.75	0.4626	128	195	A11011.75
	12.00	0.4724	134	205	A11012.0
	12.10	0.4764	134	205	A11012.1
	12.25	0.4823	134	205	A11012.25
	12.50	0.4921	134	205	A11012.5
1/2	12.70	0.5000	134	205	A1101/2
	13.00	0.5118	134	205	A11013.0
17/32	13.49	0.5311	140	214	A11017/32
	13.50	0.5315	140	214	A11013.5
	14.00	0.5512	140	214	A11014.0
9/16	14.29	0.5626	144	220	A1109/16
	14.50	0.5709	144	220	A11014.5
	15.00	0.5906	144	220	A11015.0
	15.50	0.6102	149	227	A11015.5
5/8	15.88	0.6252	149	227	A1105/8
	16.00	0.6299	149	227	A11016.0
	16.50	0.6496	154	235	A11016.5
	17.00	0.6693	154	235	A11017.0
11/16	17.46	0.6874	158	241	A11011/16
	17.50	0.6890	158	241	A11017.5
	18.00	0.7087	158	241	A11018.0
	18.50	0.7283	162	247	A11018.5
	19.00	0.7480	162	247	A11019.0
3/4	19.05	0.7500	166	254	A1103/4
	19.50	0.7677	166	254	A11019.5
	20.00	0.7874	166	254	A11020.0
	21.00	0.8268	171	261	A11021.0
	22.00	0.8661	176	268	A11022.0
7/8	22.22	0.8748	176	268	A1107/8
15/16	23.81	0.9374	185	282	A11015/16
1"	25.40	1.0000	190	290	A1101

- A940** • Punte PFX serie lunga
 • PFX - Tieflochspiralbohrer, lang
- A941** • PFX Diepgatspiraalboor
 • Foret PFX série longue

A940	▪	1.1	1.2	1.3	1.4	1.5	1.6	2.1	2.2	2.3	4.1	4.2	4.3	7.2	
	•	3.2	3.3	3.4	6.1	6.2	6.3	6.4	7.1	7.3	7.4	8.1	8.2		
A941	▪	1.1	1.2	1.3	1.4	1.5	1.6	2.1	2.2	2.3	3.1	3.2	3.3	3.4	7.4
	•	4.1	4.2	4.3	6.3	6.4									

A940	HSS-E	DIN ANSI	10XD	130°			W			
A941	HSS-E	DIN ANSI	10XD	130°	Alcrona Top		W			

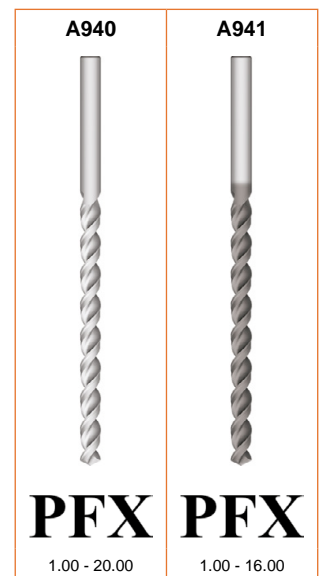
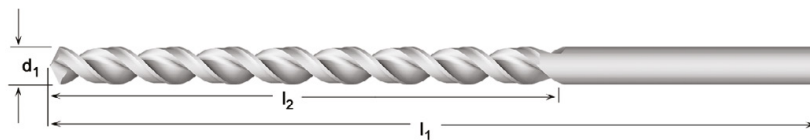

d_1 $\varnothing h_8$ Inch	d_1 $\varnothing h_8$ mm	d_1 decimal Inch	l_2 mm	l_1 mm	A940	A941
	1.00	0.0394	33	56	A9401.0	A9411.0
	1.10	0.0433	37	60	A9401.1	
3/64	1.19	0.0469	29	57	A9403/64	A9413/64
	1.20	0.0472	41	65	A9401.2	
	1.30	0.0512	41	65	A9401.3	
	1.40	0.0551	45	70	A9401.4	
1/16	1.50	0.0591	45	70	A9401.5	A9411.5
	1.59	0.0626	44	76	A9401/16	A9411/16
	1.60	0.0630	50	76	A9401.6	
	1.70	0.0669	50	76	A9401.7	
	1.80	0.0709	53	80	A9401.8	
	1.90	0.0748	53	80	A9401.9	
5/64	1.98	0.0780	51	95	A9405/64	A9415/64
	2.00	0.0787	56	85	A9402.0	A9412.0
	2.10	0.0827	56	85	A9402.1	
	2.20	0.0866	59	90	A9402.2	
	2.30	0.0906	59	90	A9402.3	
3/32	2.38	0.0937	57	108	A9403/32	A9413/32
	2.40	0.0945	62	95	A9402.4	
	2.50	0.0984	62	95	A9402.5	A9412.5
	2.60	0.1024	62	95	A9402.6	
	2.70	0.1063	66	100	A9402.7	
7/64	2.78	0.1094	64	117	A9407/64	A9417/64
	2.80	0.1102	66	100	A9402.8	
	2.90	0.1142	66	100	A9402.9	
	3.00	0.1181	66	100	A9403.0	A9413.0

d_1 $\varnothing h_8$ Inch	d_1 $\varnothing h_8$ mm	d_1 decimal Inch	l_2 mm	l_1 mm	A940	A941
1/8	3.10	0.1220	69	106	A9403.1	A9413.1
	3.18	0.1252	70	130	A9401/8	A9411/8
	3.20	0.1260	69	106	A9403.2	A9413.2
	3.30	0.1299	69	106	A9403.3	A9413.3
	3.40	0.1339	73	112	A9403.4	A9413.4
9/64	3.50	0.1378	73	112	A9403.5	A9413.5
	3.57	0.1406	76	137	A9409/64	A9419/64
	3.60	0.1417	73	112	A9403.6	A9413.6
	3.70	0.1457	73	112	A9403.7	A9413.7
	3.80	0.1496	78	119	A9403.8	A9413.8
5/32	3.90	0.1535	78	119	A9403.9	A9413.9
	3.97	0.1563	76	137	A9405/32	A9415/32
	4.00	0.1575	78	119	A9404.0	A9414.0
	4.10	0.1614	78	119	A9404.1	A9414.1
	4.20	0.1654	78	119	A9404.2	A9414.2
11/64	4.30	0.1693	82	126	A9404.3	A9414.3
	4.37	0.1720	86	146	A94011/64	A94111/64
	4.40	0.1732	82	126	A9404.4	A9414.4
	4.50	0.1772	82	126	A9404.5	A9414.5
	4.60	0.1811	82	126	A9404.6	A9414.6
3/16	4.70	0.1850	82	126	A9404.7	A9414.7
	4.76	0.1874	86	146	A9403/16	A9413/16
	4.80	0.1890	87	132	A9404.8	A9414.8
	4.90	0.1929	87	132	A9404.9	A9414.9
	5.00	0.1969	87	132	A9405.0	A9415.0
13/64	5.10	0.2008	87	132	A9405.1	A9415.1
	5.16	0.2031	92	152	A94013/64	A94113/64
	5.20	0.2047	87	132	A9405.2	A9415.2
	5.30	0.2087	87	132	A9405.3	A9415.3
	5.40	0.2126	91	139	A9405.4	A9415.4
7/32	5.50	0.2165	91	139	A9405.5	A9415.5
	5.56	0.2189	92	152	A9407/32	A9417/32
	5.60	0.2205	91	139	A9405.6	A9415.6
	5.70	0.2244	91	139	A9405.7	A9415.7
	5.80	0.2283	91	139	A9405.8	A9415.8
15/64	5.90	0.2323	91	139	A9405.9	A9415.9
	5.95	0.2343	95	156	A94015/64	A94115/64
	6.00	0.2362	91	139	A9406.0	A9416.0
	6.10	0.2402	97	148	A9406.1	A9416.1
	6.20	0.2441	97	148	A9406.2	A9416.2
1/4	6.30	0.2480	97	148	A9406.3	A9416.3
	6.35	0.2500	95	156	A9401/4	A9411/4
	6.40	0.2520	97	148	A9406.4	A9416.4
	6.50	0.2559	97	148	A9406.5	A9416.5
	6.60	0.2598	97	148	A9406.6	A9416.6
17/64	6.70	0.2638	97	148	A9406.7	A9416.7
	6.75	0.2657	98	159	A94017/64	A94117/64
	6.80	0.2677	102	156	A9406.8	A9416.8
	6.90	0.2717	102	156	A9406.9	A9416.9
	7.00	0.2756	102	156	A9407.0	A9417.0
9/32	7.10	0.2795	102	156	A9407.1	A9417.1
	7.14	0.2811	98	159	A9409/32	A9419/32
	7.20	0.2835	102	156	A9407.2	A9417.2
	7.30	0.2874	102	156	A9407.3	A9417.3
	7.40	0.2913	102	156	A9407.4	A9417.4
19/64	7.50	0.2953	102	156	A9407.5	A9417.5
	7.54	0.2969	102	162	A94019/64	A94119/64
	7.60	0.2992	109	165	A9407.6	A9417.6
	7.70	0.3031	109	165	A9407.7	A9417.7
	7.80	0.3071	109	165	A9407.8	A9417.8
5/16	7.90	0.3110	109	165	A9407.9	A9417.9
	7.94	0.3126	102	162	A9405/16	A9415/16
	8.00	0.3150	109	165	A9408.0	A9418.0
	8.10	0.3189	109	165	A9408.1	A9418.1
	8.20	0.3228	109	165	A9408.2	A9418.2
21/64	8.30	0.3268	109	165	A9408.3	A9418.3
	8.33	0.3280	105	165	A94021/64	A94121/64
	8.40	0.3307	109	165	A9408.4	A9418.4
	8.50	0.3346	109	165	A9408.5	A9418.5
	8.60	0.3386	115	175	A9408.6	A9418.6

d_1 $\varnothing h_8$ Inch	d_1 $\varnothing h_8$ mm	d_1 decimal Inch	l_2 mm	l_1 mm	A940	A941
11/32	8.70	0.3425	115	175	A9408.7	A9418.7
	8.73	0.3437	105	165	A94011/32	A94111/32
	8.80	0.3465	115	175	A9408.8	A9418.8
	8.90	0.3504	115	175	A9408.9	A9418.9
	9.00	0.3543	115	175	A9409.0	A9419.0
23/64	9.10	0.3583	115	175	A9409.1	A9419.1
	9.13	0.3594	108	171	A94023/64	A94123/64
	9.20	0.3622	115	175	A9409.2	A9419.2
	9.30	0.3661	115	175	A9409.3	A9419.3
	9.40	0.3701	115	175	A9409.4	A9419.4
3/8	9.50	0.3740	115	175	A9409.5	A9419.5
	9.52	0.3748	108	171	A9403/8	A9413/8
	9.60	0.3780	121	184	A9409.6	A9419.6
	9.70	0.3819	121	184	A9409.7	A9419.7
	9.80	0.3858	121	184	A9409.8	A9419.8
25/64	9.90	0.3898	121	184	A9409.9	A9419.9
	9.92	0.3906	111	178	A94025/64	A94125/64
	10.00	0.3937	121	184	A94010.0	A94110.0
	10.20	0.4016	121	184	A94010.2	A94110.2
	10.30	0.4055	121	184	A94010.3	A94110.3
13/32	10.32	0.4063	111	178	A94013/32	A94113/32
	10.50	0.4134	121	184	A94010.5	A94110.5
27/64	10.72	0.4220	117	184	A94027/64	A94127/64
	11.00	0.4331	128	195	A94011.0	A94111.0
7/16	11.11	0.4374	117	184	A9407/16	A9417/16
	11.20	0.4409	128	195	A94011.2	A94111.2
	11.50	0.4528	128	195	A94011.5	A94111.5
29/64	11.51	0.4531	121	190	A94029/64	A94129/64
	11.80	0.4646	128	195	A94011.8	A94111.8
15/32	11.91	0.4689	121	190	A94015/32	A94115/32
	12.00	0.4724	134	205	A94012.0	A94112.0
	12.20	0.4803	134	205	A94012.2	A94112.2
31/64	12.30	0.4843	121	197	A94031/64	A94131/64
	12.50	0.4921	134	205	A94012.5	A94112.5
1/2	12.70	0.5000	121	197	A9401/2	A9411/2
33/64	13.00	0.5118	134	205	A94013.0	A94113.0
	13.10	0.5157	121	203	A94033/64	A94133/64
17/32	13.49	0.5311	121	203	A94017/32	
	13.50	0.5315	140	214	A94013.5	A94113.5
35/64	13.89	0.5469	124	210	A94035/64	A94135/64
	14.00	0.5512	140	214	A94014.0	A94114.0
9/16	14.29	0.5626	124	210	A9409/16	A9419/16
	14.50	0.5709	144	220	A94014.5	A94114.5
37/64	14.68	0.5780	124	222	A94037/64	A94137/64
	15.00	0.5906	144	220	A94015.0	A94115.0
19/32	15.08	0.5937	124	222	A94019/32	A94119/32
39/64	15.48	0.6094	124	222	A94039/64	A94139/64
	15.50	0.6102	149	227	A94015.5	A94115.5
5/8	15.88	0.6252	124	222	A9405/8	A9415/8
	16.00	0.6299	149	227	A94016.0	A94116.0
41/64	16.27	0.6406	130	229	A94041/64	
	16.50	0.6496	154	235	A94016.5	
21/32	16.67	0.6563	130	229	A94021/32	
	17.00	0.6693	154	235	A94017.0	
43/64	17.07	0.6720	137	235	A94043/64	
	17.46	0.6874	137	235	A94011/16	
45/64	17.50	0.6890	158	241	A94017.5	
	17.86	0.7031	143	241	A94045/64	
23/32	18.00	0.7087	158	241	A94018.0	
	18.26	0.7189	143	241	A94023/32	
47/64	18.65	0.7343	149	248	A94047/64	
	19.00	0.7480	162	247	A94019.0	
3/4	19.05	0.7500	149	248	A9403/4	
49/64	19.45	0.7657	152	251	A94049/64	
25/32	19.84	0.7811	152	251	A94025/32	
	20.00	0.7874	166	254	A94020.0	

- ## A125
- Punta serie extra lunga
 - Spiralbohrer, extra lang
 - Extra lange boor
 - Foret queue cône morse - Extra long

Senza trattamento sotto 2,2 mm, 5/64"
 Blank bis 2,2 mm Ø
 Blank beneden 2,2mm, 5/16"
 Brillant au dessous de 2,2 mm, 5/64

A125	▪	1.1	1.2																		
	•	1.3	1.4	1.5	1.6	2.1	2.2	2.3	3.1	3.2	3.3	3.4	4.1	4.2	4.3	5.1	5.2	5.3	6.1	6.2	6.3
		6.4	7.1	7.2	7.3	7.4	8.1	8.2	8.3	9.1											

A125 HSS BS 328 10XD 118° ST N

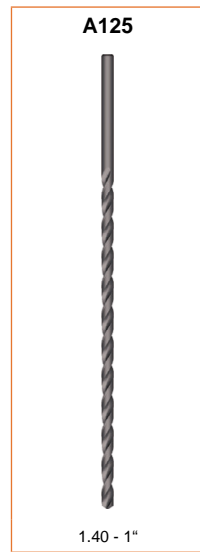
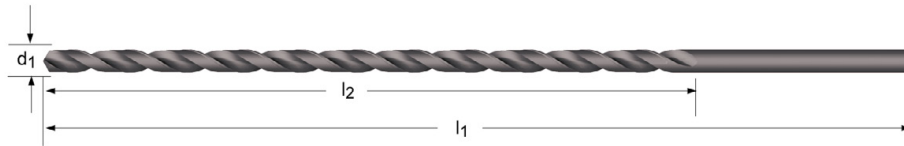

d_1 Ø _{h8} Inch	d_1 Ø _{h8} mm	d_1 decimal Inch	l_2 mm	l_1 mm	A125
	1.40	0.0551	100	160	A1251.4X160
	1.50	0.0591	80	125	A1251.5X125
	1.50	0.0591	100	160	A1251.5X160
1/16	1.59	0.0626	80	125	A1251/16X125
1/16	1.59	0.0626	100	160	A1251/16X160
	1.80	0.0709	100	160	A1251.8X160
5/64	1.98	0.0780	80	125	A1255/64X125
5/64	1.98	0.0780	100	160	A1255/64X160
	2.00	0.0787	80	125	A1252.0X125
	2.00	0.0787	100	160	A1252.0X160
	2.20	0.0866	100	160	A1252.2X160
3/32	2.38	0.0937	80	125	A1253/32X125
3/32	2.38	0.0937	100	160	A1253/32X160
	2.50	0.0984	80	125	A1252.5X125
	2.50	0.0984	100	160	A1252.5X160
7/64	2.78	0.1094	80	125	A1257/64X125
7/64	2.78	0.1094	100	160	A1257/64X160
	3.00	0.1181	100	160	A1253.0X160
	3.00	0.1181	150	200	A1253.0X200
	3.00	0.1181	200	250	A1253.0X250
1/8	3.18	0.1252	100	160	A1251/8X160
1/8	3.18	0.1252	150	200	A1251/8X200
1/8	3.18	0.1252	200	250	A1251/8X250
1/8	3.18	0.1252	250	310	A1251/8X315
	3.30	0.1299	100	160	A1253.3X160
	3.50	0.1378	100	160	A1253.5X160
	3.50	0.1378	150	200	A1253.5X200
	3.50	0.1378	200	250	A1253.5X250
9/64	3.57	0.1406	100	160	A1259/64X160
9/64	3.57	0.1406	150	200	A1259/64X200
9/64	3.57	0.1406	250	310	A1259/64X315
5/32	3.97	0.1563	100	160	A1255/32X160
5/32	3.97	0.1563	150	200	A1255/32X200
5/32	3.97	0.1563	200	250	A1255/32X250

d_1 \varnothing_{h_8} Inch	d_1 \varnothing_{h_8} mm	d_1 decimal inch	l_2 mm	l_1 mm	A125
5/32	3.97	0.1563	250	310	A1255/32X315
	4.00	0.1575	100	160	A1254.0X160
	4.00	0.1575	150	200	A1254.0X200
	4.00	0.1575	200	250	A1254.0X250
	4.00	0.1575	250	310	A1254.0X315
11/64	4.37	0.1720	100	160	A12511/64X160
11/64	4.37	0.1720	150	200	A12511/64X200
11/64	4.37	0.1720	250	310	A12511/64X315
	4.50	0.1772	100	160	A1254.5X160
	4.50	0.1772	150	200	A1254.5X200
	4.50	0.1772	200	250	A1254.5X250
	4.50	0.1772	250	310	A1254.5X315
3/16	4.76	0.1874	100	160	A1253/16X160
3/16	4.76	0.1874	150	200	A1253/16X200
3/16	4.76	0.1874	200	250	A1253/16X250
3/16	4.76	0.1874	250	310	A1253/16X315
3/16	4.76	0.1874	300	400	A1253/16X400
	5.00	0.1969	100	160	A1255.0X160
	5.00	0.1969	150	200	A1255.0X200
	5.00	0.1969	200	250	A1255.0X250
	5.00	0.1969	250	310	A1255.0X315
	5.00	0.1969	300	400	A1255.0X400
13/64	5.16	0.2031	150	200	A12513/64X200
13/64	5.16	0.2031	200	250	A12513/64X250
13/64	5.16	0.2031	250	310	A12513/64X315
	5.50	0.2165	150	200	A1255.5X200
	5.50	0.2165	200	250	A1255.5X250
	5.50	0.2165	250	310	A1255.5X315
7/32	5.56	0.2189	150	200	A1257/32X200
7/32	5.56	0.2189	200	250	A1257/32X250
7/32	5.56	0.2189	250	310	A1257/32X315
15/64	5.95	0.2343	150	200	A12515/64X200
15/64	5.95	0.2343	200	250	A12515/64X250
15/64	5.95	0.2343	250	310	A12515/64X315
	6.00	0.2362	150	200	A1256.0X200
	6.00	0.2362	200	250	A1256.0X250
	6.00	0.2362	250	310	A1256.0X315
	6.00	0.2362	300	400	A1256.0X400
1/4	6.35	0.2500	150	200	A1251/4X200
1/4	6.35	0.2500	200	250	A1251/4X250
1/4	6.35	0.2500	250	310	A1251/4X315
1/4	6.35	0.2500	300	400	A1251/4X400
1/4	6.35	0.2500	400	460	A1251/4X500
	6.50	0.2559	150	200	A1256.5X200
	6.50	0.2559	200	250	A1256.5X250
	6.50	0.2559	250	310	A1256.5X315
17/64	6.75	0.2657	150	200	A12517/64X200
17/64	6.75	0.2657	200	250	A12517/64X250
17/64	6.75	0.2657	400	460	A12517/64X500
	7.00	0.2756	150	200	A1257.0X200
	7.00	0.2756	200	250	A1257.0X250
	7.00	0.2756	250	310	A1257.0X315
9/32	7.14	0.2811	150	200	A1259/32X200
9/32	7.14	0.2811	200	250	A1259/32X250
9/32	7.14	0.2811	250	310	A1259/32X315
9/32	7.14	0.2811	400	460	A1259/32X500
	7.50	0.2953	150	200	A1257.5X200
	7.50	0.2953	200	250	A1257.5X250
	7.50	0.2953	250	310	A1257.5X315
19/64	7.54	0.2969	250	310	A12519/64X315
19/64	7.54	0.2969	400	460	A12519/64X500
5/16	7.94	0.3126	150	200	A1255/16X200
5/16	7.94	0.3126	200	250	A1255/16X250
5/16	7.94	0.3126	250	310	A1255/16X315
5/16	7.94	0.3126	300	400	A1255/16X400
5/16	7.94	0.3126	400	460	A1255/16X500
	8.00	0.3150	200	250	A1258.0X250
	8.00	0.3150	250	310	A1258.0X315
	8.00	0.3150	300	400	A1258.0X400
21/64	8.33	0.3280	250	310	A12521/64X315

d_1 $\varnothing h_8$ Inch	d_1 $\varnothing h_8$ mm	d_1 decimal Inch	l_2 mm	l_1 mm	A125
21/64	8.33	0.3280	400	460	A12521/64X500
	8.50	0.3346	200	250	A1258.5X250
	8.50	0.3346	250	310	A1258.5X315
11/32	8.73	0.3437	200	250	A12511/32X250
11/32	8.73	0.3437	250	310	A12511/32X315
11/32	8.73	0.3437	300	400	A12511/32X400
11/32	8.73	0.3437	400	460	A12511/32X500
	9.00	0.3543	200	250	A1259.0X250
	9.00	0.3543	250	310	A1259.0X315
	9.00	0.3543	300	400	A1259.0X400
23/64	9.13	0.3594	250	310	A12523/64X315
23/64	9.13	0.3594	400	460	A12523/64X500
	9.50	0.3740	200	250	A1259.5X250
	9.50	0.3740	250	310	A1259.5X315
3/8	9.52	0.3748	200	250	A1253/8X250
3/8	9.52	0.3748	250	310	A1253/8X315
3/8	9.52	0.3748	300	400	A1253/8X400
3/8	9.52	0.3748	400	460	A1253/8X500
25/64	9.92	0.3906	250	310	A12525/64X315
25/64	9.92	0.3906	400	460	A12525/64X500
	10.00	0.3937	200	250	A12510.0X250
	10.00	0.3937	250	310	A12510.0X315
	10.00	0.3937	300	400	A12510.0X400
13/32	10.32	0.4063	200	250	A12513/32X250
13/32	10.32	0.4063	250	310	A12513/32X315
13/32	10.32	0.4063	400	460	A12513/32X500
	10.50	0.4134	200	250	A12510.5X250
	10.50	0.4134	250	310	A12510.5X315
	10.50	0.4134	300	400	A12510.5X400
27/64	10.72	0.4220	250	310	A12527/64X315
	11.00	0.4331	200	250	A12511.0X250
	11.00	0.4331	250	310	A12511.0X315
	11.00	0.4331	300	400	A12511.0X400
7/16	11.11	0.4374	200	250	A1257/16X250
7/16	11.11	0.4374	250	310	A1257/16X315
7/16	11.11	0.4374	300	400	A1257/16X400
7/16	11.11	0.4374	400	460	A1257/16X500
29/64	11.51	0.4531	250	310	A12529/64X315
29/64	11.51	0.4531	400	460	A12529/64X500
15/32	11.91	0.4689	200	250	A12515/32X250
15/32	11.91	0.4689	250	310	A12515/32X315
15/32	11.91	0.4689	400	460	A12515/32X500
	12.00	0.4724	200	250	A12512.0X250
	12.00	0.4724	250	310	A12512.0X315
	12.00	0.4724	300	400	A12512.0X400
31/64	12.30	0.4843	250	310	A12531/64X315
31/64	12.30	0.4843	400	460	A12531/64X500
1/2	12.70	0.5000	200	250	A1251/2X250
1/2	12.70	0.5000	250	310	A1251/2X315
1/2	12.70	0.5000	300	400	A1251/2X400
1/2	12.70	0.5000	400	460	A1251/2X500
	13.00	0.5118	250	310	A12513.0X315
	13.00	0.5118	300	400	A12513.0X400
33/64	13.10	0.5157	250	310	A12533/64X315
33/64	13.10	0.5157	400	460	A12533/64X500
17/32	13.49	0.5311	250	310	A12517/32X315
17/32	13.49	0.5311	400	460	A12517/32X500
35/64	13.89	0.5469	250	310	A12535/64X315
35/64	13.89	0.5469	400	460	A12535/64X500
	14.00	0.5512	250	310	A12514.0X315
	14.00	0.5512	300	400	A12514.0X400
9/16	14.29	0.5626	250	310	A1259/16X315
9/16	14.29	0.5626	400	460	A1259/16X500
37/64	14.68	0.5780	250	310	A12537/64X315
19/32	15.08	0.5937	250	310	A12519/32X315
19/32	15.08	0.5937	400	460	A12519/32X500
39/64	15.48	0.6094	250	310	A12539/64X315
39/64	15.48	0.6094	400	460	A12539/64X500
5/8	15.88	0.6252	250	310	A1255/8X315
5/8	15.88	0.6252	400	460	A1255/8X500

d_1 $\varnothing h_8$ Inch	d_1 $\varnothing h_8$ mm	d_1 decimal Inch	l_2 mm	l_1 mm	A125
21/32	16.67	0.6563	250	310	A12521/32X315
21/32	16.67	0.6563	400	460	A12521/32X500
11/16	17.46	0.6874	250	310	A12511/16X315
11/16	17.46	0.6874	400	460	A12511/16X500
23/32	18.26	0.7189	250	310	A12523/32X315
23/32	18.26	0.7189	400	460	A12523/32X500
3/4	19.05	0.7500	250	310	A1253/4X315
3/4	19.05	0.7500	400	460	A1253/4X500
25/32	19.84	0.7811	400	460	A12525/32X500
13/16	20.64	0.8126	400	460	A12513/16X500
7/8	22.22	0.8748	400	460	A1257/8X500
15/16	23.81	0.9374	400	460	A12515/16X500
1"	25.40	1.0000	400	460	A1251X500

A976 • Punte PFX serie extra lunga

A977 • PFX - Tieflochspiralbohrer, extra lang

A978 • Foret PFX extra-long

A976; A977; A978	▪	1.3	1.4	1.5	1.6													
	•	1.1	1.2	2.1	2.2	2.3	3.2	3.3	3.4	4.1	4.2	4.3	6.3	6.4	7.4			

A976	HSS-E	DIN 1869/1	15XD	130°			W			
A977	HSS-E	DIN 1869/2	20XD	130°			W			
A978	HSS-E	DIN 1869/3	25XD	130°			W			

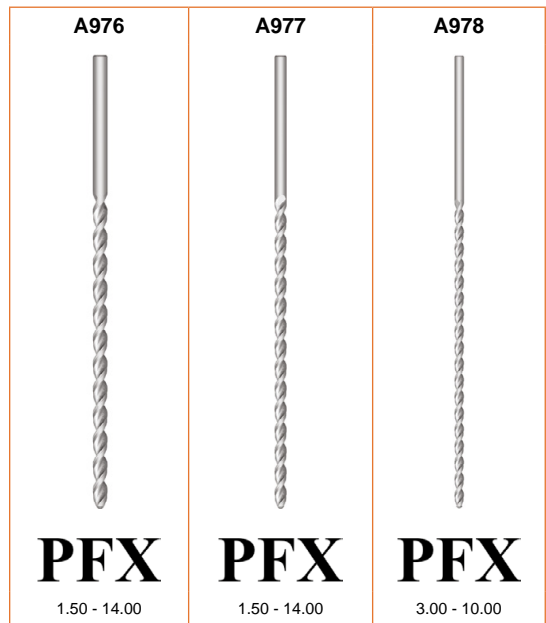
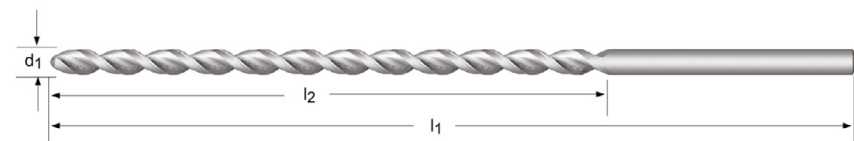

d_1 $\varnothing h_8$ Inch	d_1 $\varnothing h_8$ mm	d_1 decimal Inch	l_2 mm	l_1 mm	A976	A977	A978
	1.50	0.0591	75	115	A9761.5		
1/16	1.50	0.0591	100	150		A9771.5 ⁴⁾	
	1.59	0.0626	100	150		A9771/16 ⁴⁾	
	2.00	0.0787	110	160		A9772.0 ⁴⁾	
	2.00	0.0787	85	125	A9762.0X125		
3/32	2.10	0.0827	85	125	A9762.1X125		
	2.20	0.0866	90	135	A9762.2X135		
	2.30	0.0906	90	135	A9762.3X135		
	2.38	0.0937	115	170		A9773/32 ⁴⁾	
	2.40	0.0945	95	140	A9762.4X140		
	2.50	0.0984	95	140	A9762.5X140		
	2.60	0.1024	95	140	A9762.6X140		
	2.70	0.1063	100	150	A9762.7X150		
	2.80	0.1102	100	150	A9762.8X150		
	2.90	0.1142	100	150	A9762.9X150		
	3.00	0.1181	100	150	A9763.0X150		
	3.00	0.1181	130	190		A9773.0X190	
1/8	3.00	0.1181	160	240			A9783.0 ⁴⁾
	3.10	0.1220	105	155	A9763.1X155		
	3.18	0.1252	105	155	A9761/8		

⁴⁾ Norma Dormer / Werksnorm / Spiraalgroef en totale lengte volgens Dormer standaard / Goujure et longueur totale selon la norme usine

d_1 $\varnothing h_8$ Inch	d_1 $\varnothing h_8$ mm	d_1 decimal Inch	l_2 mm	l_1 mm	A976	A977	A978	
1/8	3.18	0.1252	135	200				
	3.20	0.1260	105	155	A9763.2X155	A9771/8		
	3.30	0.1299	105	155	A9763.3X155			
	3.40	0.1339	115	165	A9763.4X165			
	3.50	0.1378	115	165	A9763.5X165			
	3.50	0.1378	145	210		A9773.5X210		
	3.50	0.1378	180	265			A9783.5X265	
	3.60	0.1417	115	165	A9763.6X165			
	3.70	0.1457	115	165	A9763.7X165			
	3.80	0.1496	120	175	A9763.8X175			
5/32	3.90	0.1535	120	175	A9763.9X175			
	3.97	0.1563	120	175	A9765/32			
	4.00	0.1575	120	175	A9764.0X175			
	4.00	0.1575	150	220		A9774.0X220		
	4.00	0.1575	190	280			A9784.0X280	
	4.10	0.1614	120	175	A9764.1X175			
	4.20	0.1654	120	175	A9764.2X175			
	4.30	0.1693	125	185	A9764.3X185			
	4.40	0.1732	125	185	A9764.4X185			
	4.50	0.1772	125	185	A9764.5X185			
3/16	4.50	0.1772	160	235		A9774.5X235		
	4.50	0.1772	200	295			A9784.5X295	
	4.60	0.1811	125	185	A9764.6X185			
	4.70	0.1850	125	185	A9764.7X185			
	4.76	0.1874	135	195	A9763/16			
	3/16	4.76	0.1874	170	245		A9773/16	
		4.80	0.1890	135	195	A9764.8X195		
		4.90	0.1929	135	195	A9764.9X195		
		5.00	0.1969	135	195	A9765.0X195		
		5.00	0.1969	170	245		A9775.0X245	
5.00		0.1969	210	315			A9785.0X315	
5.10		0.2008	135	195	A9765.1X195			
5.20		0.2047	135	195	A9765.2X195			
5.30		0.2087	135	195	A9765.3X195			
5.40		0.2126	140	205	A9765.4X205			
1/4	5.50	0.2165	140	205	A9765.5X205			
	5.50	0.2165	180	260		A9775.5X260		
	5.50	0.2165	225	330			A9785.5X330	
	5.60	0.2205	140	205	A9765.6X205			
	5.70	0.2244	140	205	A9765.7X205			
	5.80	0.2283	140	205	A9765.8X205			
	5.90	0.2323	140	205	A9765.9X205			
	6.00	0.2362	140	205	A9766.0X205			
	6.00	0.2362	180	260		A9776.0X260		
	6.00	0.2362	225	330			A9786.0X330	
1/4	6.10	0.2402	150	215	A9766.1X215			
	6.20	0.2441	150	215	A9766.2X215			
	6.30	0.2480	150	215	A9766.3X215			
	6.35	0.2500	150	215	A9761/4			
	6.35	0.2500	190	275		A9771/4		
	1/4	6.35	0.2500	235	350			A9781/4
		6.40	0.2520	150	215	A9766.4X215		
		6.50	0.2559	150	215	A9766.5X215		
		6.50	0.2559	190	275		A9776.5X275	
		6.50	0.2559	235	350			A9786.5X350
6.60		0.2598	150	215	A9766.6X215			
6.70		0.2638	150	215	A9766.7X215			
6.80		0.2677	155	225	A9766.8X225			
6.90		0.2717	155	225	A9766.9X225			
7.00		0.2756	155	225	A9767.0X225			
5/16	7.00	0.2756	200	290		A9777.0X290		
	7.00	0.2756	250	370			A9787.0X370	
	7.50	0.2953	155	225	A9767.5X225			
	7.50	0.2953	200	290		A9777.5X290		
	7.50	0.2953	250	370			A9787.5X370	
	7.94	0.3126	165	240	A9765/16			
	8.00	0.3150	165	240	A9768.0X240			
	8.00	0.3150	210	305		A9778.0X305		
	8.00	0.3150	265	390			A9788.0X390	
	8.50	0.3346	165	240	A9768.5X240			

d_1 $\varnothing h_8$ Inch	d_1 $\varnothing h_8$ mm	d_1 decimal Inch	l_2 mm	l_1 mm	A976	A977	A978
	8.50	0.3346	210	305		A9778.5X305	
	8.50	0.3346	265	390			A9788.5X390
11/32	8.73	0.3437	175	250	A97611/32		
11/32	8.73	0.3437	220	320		A97711/32	
	9.00	0.3543	175	250	A9769.0X250		
	9.00	0.3543	220	320		A9779.0X320	
	9.00	0.3543	280	410			A9789.0X410
	9.50	0.3740	175	250	A9769.5X250		
	9.50	0.3740	220	320		A9779.5X320	
	9.50	0.3740	280	410			A9789.5X410
3/8	9.52	0.3748	185	265	A9763/8		
	10.00	0.3937	185	265	A97610.0X265		
	10.00	0.3937	235	340		A97710.0X340	
	10.00	0.3937	295	430			A97810.0X430
	10.50	0.4134	185	265	A97610.5		
	10.50	0.4134	235	340		A97710.5	
	11.00	0.4331	195	280	A97611.0		
	11.00	0.4331	250	365		A97711.0	
7/16	11.11	0.4374	195	280	A9767/16		
	11.50	0.4528	195	280	A97611.5		
	11.50	0.4528	250	365		A97711.5	
	12.00	0.4724	205	295	A97612.0		
	12.00	0.4724	260	375		A97712.0	
	12.50	0.4921	205	295	A97612.5		
	12.50	0.4921	260	375		A97712.5	
1/2	12.70	0.5000	205	295	A9761/2		
	13.00	0.5118	205	295	A97613.0		
	13.00	0.5118	260	375		A97713.0	
	14.00	0.5512	215	310	A97614.0		
	14.00	0.5512	270	390		A97714.0	

⁴⁾ Norma Dormer / Werksnorm / Spiraalgroef en totale lengte volgens Dormer standaard / Goujure et longueur totale selon la norme usine

- A130**
- Punta codolo Morse
 - Spiralbohrer, MK
- A530**
- Spiraalboor met morseconus
 - Foret queue cône morse

Sopra 14,0 mm - Nucleo assottigliato
 über 14 mm Ø ausgespitzt
 Boven Ø 14,0mm - uitgedund
 Au dessus du Ø 14,0 mm - Pointe amincie

- A730**
- Punta codolo Morse
 - Spiralbohrer, MK
 - Spiraalboor met morseconus
 - Foret queue cône morse

A130	▪	1.1	1.2	1.3	1.4	3.1	3.2														
	•	1.5	1.6	2.1	2.2	2.3	3.3	3.4	4.1	4.2	4.3	5.1	5.2	5.3	6.1	6.2	6.3	6.4	7.1	7.2	7.3
		7.4	8.1	8.2	8.3	9.1															
A530	▪	1.1	1.2	1.3	1.4	3.2	3.3	6.3													
	•	1.5	1.6	2.1	2.2	2.3	3.1	3.4	4.1	4.2	4.3	5.1	5.2	5.3	6.1	6.2	6.4	7.1	7.2	7.3	7.4
		8.1	8.2	8.3	9.1																
A730	▪	1.5	1.6	2.2	2.3	3.4															
	•	1.1	1.2	1.3	1.4	2.1	3.1	3.2	3.3	4.1	4.2	4.3	5.1	5.2	5.3	6.1	6.2	6.3	6.4	7.1	7.2
		7.3	7.4	8.1	8.2	8.3	9.1														

A130	HSS	DIN 345	4XD	118°	ST		N			
A530	HSS	DIN 345	4XD	118°	TiN		N			
A730	HSS-E	DIN 345	4XD	118°	Bronze		N			

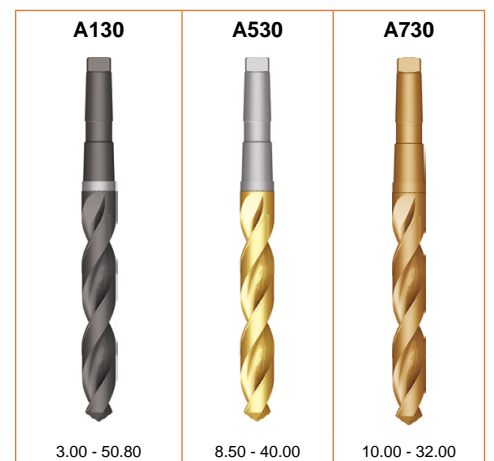
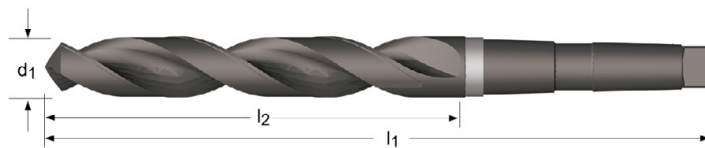

d_1 Øh ₈ Inch	d_1 Øh ₈ mm	d_1 decimal Inch	l_2 mm	l_1 mm	MK	A130	A530	A730
1/8	3.00	0.1181	33	114	1	A1303.0		
	3.18	0.1252	36	117	1	A1301/8		
	3.20	0.1260	36	117	1	A1303.2		
	3.25	0.1280	36	117	1	A1303.25		
	3.30	0.1299	36	117	1	A1303.3		
9/64	3.50	0.1378	39	120	1	A1303.5		
	3.57	0.1406	39	120	1	A1309/64		
	3.75	0.1476	39	120	1	A1303.75		
5/32	3.97	0.1563	43	124	1	A1305/32		
	4.00	0.1575	43	124	1	A1304.0		
	4.10	0.1614	43	124	1	A1304.1		
	4.20	0.1654	43	124	1	A1304.2		

d_1 $\varnothing h_8$ Inch	d_1 $\varnothing h_8$ mm	d_1 decimal Inch	l_2 mm	l_1 mm	MK	A130	A530	A730
11/64	4.25	0.1673	43	124	1	A1304.25		
	4.37	0.1720	47	128	1	A13011/64		
	4.50	0.1772	47	128	1	A1304.5		
3/16	4.75	0.1870	52	128	1	A1304.75		
	4.76	0.1874	52	133	1	A1303/16		
	4.80	0.1890	52	133	1	A1304.8		
	4.90	0.1929	52	133	1	A1304.9		
	5.00	0.1969	52	133	1	A1305.0		
13/64	5.10	0.2008	52	133	1	A1305.1		
	5.16	0.2031	52	133	1	A13013/64		
	5.20	0.2047	52	133	1	A1305.2		
	5.25	0.2067	52	133	1	A1305.25		
	5.40	0.2126	57	138	1	A1305.4		
7/32	5.50	0.2165	57	138	1	A1305.5		
	5.56	0.2189	57	138	1	A1307/32		
	5.70	0.2244	57	138	1	A1305.7		
	5.75	0.2264	57	138	1	A1305.75		
	5.80	0.2283	57	138	1	A1305.8		
15/64	5.90	0.2323	57	138	1	A1305.9		
	5.95	0.2343	57	138	1	A13015/64		
	6.00	0.2362	57	138	1	A1306.0		
	6.10	0.2402	63	144	1	A1306.1		
	6.20	0.2441	63	144	1	A1306.2		
1/4	6.25	0.2461	63	144	1	A1306.25		
	6.30	0.2480	63	144	1	A1306.3		
	6.35	0.2500	63	144	1	A1301/4		
	6.40	0.2520	63	144	1	A1306.4		
	6.50	0.2559	63	144	1	A1306.5		
	6.60	0.2598	63	144	1	A1306.6		
	6.70	0.2638	63	144	1	A1306.7		
17/64	6.75	0.2657	69	150	1	A13017/64		
	6.75	0.2657	69	150	1	A1306.75		
	6.80	0.2677	69	150	1	A1306.8		
	6.90	0.2717	69	150	1	A1306.9		
	7.00	0.2756	69	150	1	A1307.0		
9/32	7.14	0.2811	69	150	1	A1309/32		
	7.20	0.2835	69	150	1	A1307.2		
	7.25	0.2854	69	150	1	A1307.25		
	7.30	0.2874	69	150	1	A1307.3		
	7.40	0.2913	69	150	1	A1307.4		
19/64	7.50	0.2953	69	150	1	A1307.5		
	7.54	0.2969	75	156	1	A13019/64		
	7.70	0.3031	75	156	1	A1307.7		
	7.75	0.3051	75	156	1	A1307.75		
	7.80	0.3071	75	156	1	A1307.8		
5/16	7.90	0.3110	75	156	1	A1307.9		
	7.94	0.3126	75	156	1	A1305/16		
	8.00	0.3150	75	156	1	A1308.0		
	8.10	0.3189	75	156	1	A1308.1		
	8.20	0.3228	75	156	1	A1308.2		
21/64	8.25	0.3248	75	156	1	A1308.25		
	8.30	0.3268	75	156	1	A1308.3		
	8.33	0.3280	75	156	1	A13021/64		
	8.40	0.3307	75	156	1	A1308.4		
	8.50	0.3346	75	156	1	A1308.5	A5308.5	
11/32	8.60	0.3386	81	162	1	A1308.6		
	8.70	0.3425	81	162	1	A1308.7		
	8.73	0.3437	81	162	1	A13011/32		
	8.75	0.3445	81	162	1	A1308.75		
	8.80	0.3465	81	162	1	A1308.8		
23/64	8.90	0.3504	81	162	1	A1308.9		
	9.00	0.3543	81	162	1	A1309.0	A5309.0	
	9.10	0.3583	81	162	1	A1309.1		
	9.13	0.3594	81	162	1	A13023/64		
	9.20	0.3622	81	162	1	A1309.2		
3/8	9.25	0.3642	81	162	1	A1309.25		
	9.30	0.3661	81	162	1	A1309.3		
	9.50	0.3740	81	162	1	A1309.5		
	9.52	0.3748	87	168	1	A1303/8		
	9.60	0.3780	87	168	1	A1309.6		

d_1 \varnothing_{h_8} Inch	d_1 \varnothing_{h_8} mm	d_1 decimal Inch	l_2 mm	l_1 mm	MK	A130	A530	A730
	9.70	0.3819	87	168	1	A1309.7		
	9.75	0.3839	87	168	1	A1309.75		
	9.80	0.3858	87	168	1	A1309.8		
	9.90	0.3898	87	168	1	A1309.9		
25/64	9.92	0.3906	87	168	1	A13025/64		
	10.00	0.3937	87	168	1	A13010.0	A53010.0	A73010.0
	10.10	0.3976	87	168	1	A13010.1		
	10.20	0.4016	87	168	1	A13010.2	A53010.2	A73010.2
	10.25	0.4035	87	168	1	A13010.25		
	10.30	0.4055	87	168	1	A13010.3		
13/32	10.32	0.4063	87	168	1	A13013/32		
	10.50	0.4134	87	168	1	A13010.5	A53010.5	A73010.5
27/64	10.72	0.4220	94	175	1	A13027/64		
	10.75	0.4232	94	175	1	A13010.75		
	10.80	0.4252	94	175	1	A13010.8		A73010.8
	10.90	0.4291	94	175	1	A13010.9		
	11.00	0.4331	94	175	1	A13011.0	A53011.0	A73011.0
	11.10	0.4370	94	175	1	A13011.1		
7/16	11.11	0.4374	94	175	1	A1307/16		
	11.20	0.4409	94	175	1	A13011.2		
	11.25	0.4429	94	175	1	A13011.25		
	11.30	0.4449	94	175	1	A13011.3		
	11.40	0.4488	94	175	1	A13011.4		
	11.50	0.4528	94	175	1	A13011.5	A53011.5	A73011.5
29/64	11.51	0.4531	94	175	1	A13029/64		
	11.60	0.4567	94	175	1	A13011.6		
	11.70	0.4606	94	175	1	A13011.7		
	11.75	0.4626	94	175	1	A13011.75	A53011.75	
	11.80	0.4646	94	175	1	A13011.8		A73011.8
	11.90	0.4685	101	182	1	A13011.9		
15/32	11.91	0.4689	101	182	1	A13015/32		
	12.00	0.4724	101	182	1	A13012.0	A53012.0	A73012.0
	12.10	0.4764	101	182	1	A13012.1		
	12.20	0.4803	101	182	1	A13012.2		A73012.2
	12.25	0.4823	101	182	1	A13012.25		
31/64	12.30	0.4843	101	182	1	A13012.3		
	12.30	0.4843	101	182	1	A13031/64		
	12.40	0.4882	101	182	1	A13012.4		
	12.50	0.4921	101	182	1	A13012.5	A53012.5	A73012.5
	12.60	0.4961	101	182	1	A13012.6		
	12.70	0.5000	101	182	1	A13012.7		
1/2	12.70	0.5000	101	182	1	A1301/2		
	12.75	0.5020	101	182	1	A13012.75		
	12.80	0.5039	101	182	1	A13012.8		A73012.8
	12.90	0.5079	101	182	1	A13012.9		
	13.00	0.5118	101	182	1	A13013.0	A53013.0	A73013.0
33/64	13.10	0.5157	101	182	1	A13033/64		
	13.20	0.5197	101	182	1	A13013.2		
	13.25	0.5217	108	189	1	A13013.25		
17/32	13.49	0.5311	108	189	1	A13017/32		
	13.50	0.5315	108	189	1	A13013.5	A53013.5	A73013.5
	13.60	0.5354	108	189	1	A13013.6		
	13.70	0.5394	108	189	1	A13013.7		
	13.75	0.5413	108	189	1	A13013.75		
	13.80	0.5433	108	189	1	A13013.8		A73013.8
35/64	13.89	0.5469	108	189	1	A13035/64		
	13.90	0.5472	108	189	1	A13013.9		
	14.00	0.5512	108	189	1	A13014.0	A53014.0	A73014.0
	14.10	0.5551	114	212	2	A13014.1		
	14.20	0.5591	114	212	2	A13014.2		
	14.25	0.5610	114	212	2	A13014.25		A73014.25
9/16	14.29	0.5626	114	212	2	A1309/16		
	14.30	0.5630	114	212	2	A13014.3		
	14.40	0.5669	114	212	2	A13014.4		
	14.50	0.5709	114	212	2	A13014.5	A53014.5	A73014.5
	14.60	0.5748	114	212	2	A13014.6		
37/64	14.68	0.5780	114	212	2	A13037/64		
	14.70	0.5787	114	212	2	A13014.7		
	14.75	0.5807	114	212	2	A13014.75		A73014.75
	14.80	0.5827	114	212	2	A13014.8		

d_1 \varnothing_{h_8} Inch	d_1 \varnothing_{h_8} mm	d_1 decimal Inch	l_2 mm	l_1 mm	MK	A130	A530	A730
	14.90	0.5866	114	212	2	A13014.9		
19/32	15.00	0.5906	114	212	2	A13015.0	A53015.0	A73015.0
	15.08	0.5937	120	218	2	A13019/32		
	15.10	0.5945	120	218	2	A13015.1		
	15.20	0.5984	120	218	2	A13015.2		
39/64	15.25	0.6004	120	218	2	A13015.25	A53015.25	A73015.25
	15.48	0.6094	120	218	2	A13039/64		
	15.50	0.6102	120	218	2	A13015.5	A53015.5	A73015.5
	15.70	0.6181	120	218	2	A13015.7		
	15.75	0.6201	120	218	2	A13015.75		A73015.75
5/8	15.80	0.6220	120	218	2	A13015.8		
	15.88	0.6252	120	218	2	A1305/8		
	15.90	0.6260	120	218	2	A13015.9		
	16.00	0.6299	120	218	2	A13016.0	A53016.0	A73016.0
	16.10	0.6339	125	223	2	A13016.1		
	16.20	0.6378	125	223	2	A13016.2		
	16.25	0.6398	120	218	2			A73016.25
41/64	16.25	0.6398	125	223	2	A13016.25		
	16.27	0.6406	125	223	2	A13041/64		
21/32	16.50	0.6496	125	223	2	A13016.5	A53016.5	A73016.5
	16.67	0.6563	125	223	2	A13021/32		
	16.75	0.6594	125	223	2	A13016.75		
43/64	17.00	0.6693	125	223	2	A13017.0	A53017.0	A73017.0
	17.07	0.6720	130	228	2	A13043/64		
	17.25	0.6791	130	228	2	A13017.25		A73017.25
11/16	17.46	0.6874	130	228	2	A13011/16		
	17.50	0.6890	130	228	2	A13017.5	A53017.5	A73017.5
	17.75	0.6988	130	228	2	A13017.75		A73017.75
45/64	17.86	0.7031	130	228	2	A13045/64		
	18.00	0.7087	130	228	2	A13018.0	A53018.0	A73018.0
	18.25	0.7185	135	233	2	A13018.25		A73018.25
23/32	18.26	0.7189	135	233	2	A13023/32		
	18.50	0.7283	135	233	2	A13018.5	A53018.5	A73018.5
47/64	18.65	0.7343	135	233	2	A13047/64		
	18.75	0.7382	135	233	2	A13018.75		A73018.75
3/4	19.00	0.7480	135	233	2	A13019.0	A53019.0	A73019.0
	19.05	0.7500	140	238	2	A1303/4		
49/64	19.25	0.7579	140	238	2	A13019.25		A73019.25
	19.45	0.7657	140	238	2	A13049/64		
	19.50	0.7677	140	238	2	A13019.5	A53019.5	A73019.5
	19.75	0.7776	140	238	2	A13019.75		A73019.75
25/32	19.84	0.7811	140	238	2	A13025/32		
	20.00	0.7874	140	238	2	A13020.0	A53020.0	A73020.0
51/64	20.24	0.7969	145	243	2	A13051/64		
	20.25	0.7972	145	243	2	A13020.25		A73020.25
	20.40	0.8031	145	243	2	A13020.4		
	20.50	0.8071	145	243	2	A13020.5	A53020.5	A73020.5
13/16	20.64	0.8126	145	243	2	A13013/16		
	20.75	0.8169	145	243	2	A13020.75		A73020.75
53/64	21.00	0.8268	145	243	2	A13021.0	A53021.0	A73021.0
	21.03	0.8280	145	243	2	A13053/64		
27/32	21.25	0.8366	150	248	2	A13021.25		
	21.43	0.8437	150	248	2	A13027/32		
	21.50	0.8465	150	248	2	A13021.5	A53021.5	A73021.5
	21.75	0.8563	150	248	2	A13021.75		
55/64	21.83	0.8594	150	248	2	A13055/64		
	22.00	0.8661	150	248	2	A13022.0	A53022.0	A73022.0
7/8	22.22	0.8748	150	248	2	A1307/8		
	22.25	0.8760	150	248	2	A13022.25		
	22.50	0.8858	155	253	2	A13022.5	A53022.5	A73022.5
57/64	22.62	0.8906	155	253	2	A13057/64		
	22.75	0.8957	155	253	2	A13022.75		
	23.00	0.9055	155	253	2	A13023.0	A53023.0	A73023.0
29/32	23.02	0.9063	155	253	2	A13029/32		
	23.25	0.9154	155	276	3	A13023.25		
59/64	23.42	0.9220	155	276	3	A13059/64		
	23.50	0.9252	155	276	3	A13023.5	A53023.5	A73023.5
	23.75	0.9350	160	281	3	A13023.75		
15/16	23.81	0.9374	160	281	3	A13015/16		
	24.00	0.9449	160	281	3	A13024.0	A53024.0	A73024.0

d_1 $\varnothing_{\frac{1}{8}}$ Inch	d_1 $\varnothing_{\frac{1}{8}}$ mm	d_1 decimal Inch	l_2 mm	l_1 mm	MK	A130	A530	A730
61/64	24.21	0.9531	160	281	3	A13061/64		
	24.25	0.9547	160	281	3	A13024.25		
	24.50	0.9646	160	281	3	A13024.5	A53024.5	A73024.5
31/32	24.61	0.9689	160	281	3	A13031/32		
	24.75	0.9744	160	281	3	A13024.75		
	25.00	0.9843	160	281	3	A13025.0	A53025.0	A73025.0
63/64	25.00	0.9843	160	286	3	A13063/64		
	25.25	0.9941	165	286	3	A13025.25		
1"	25.40	1.0000	165	286	3	A1301		
	25.50	1.0039	165	286	3	A13025.5	A53025.5	A73025.5
	25.75	1.0138	165	286	3	A13025.75		
	26.00	1.0236	165	286	3	A13026.0	A53026.0	A73026.0
	26.25	1.0335	165	286	3	A13026.25		
	26.50	1.0433	165	286	3	A13026.5	A53026.5	A73026.5
	26.75	1.0531	170	291	3	A13026.75		
	26.99	1.0626	170	291	3	A1301.1/16		
1.1/16	27.00	1.0630	170	291	3	A13027.0	A53027.0	A73027.0
	27.25	1.0728	170	291	3	A13027.25		
	27.50	1.0827	170	291	3	A13027.5	A53027.5	A73027.5
	27.75	1.0925	170	291	3	A13027.75		
	28.00	1.1024	170	291	3	A13028.0	A53028.0	A73028.0
	28.25	1.1122	175	296	3	A13028.25		
	28.50	1.1220	175	296	3	A13028.5	A53028.5	A73028.5
	28.58	1.1252	175	296	3	A1301.1/8		
1.1/8	28.75	1.1319	175	296	3	A13028.75		
	29.00	1.1417	175	296	3	A13029.0	A53029.0	A73029.0
	29.25	1.1516	175	296	3	A13029.25		
	29.37	1.1563	175	296	3	A1301.5/32		
1.5/32	29.50	1.1614	175	296	3	A13029.5	A53029.5	
	29.75	1.1713	175	296	3	A13029.75		
	30.00	1.1811	175	296	3	A13030.0	A53030.0	A73030.0
	30.16	1.1874	180	301	3	A1301.3/16		
1.3/16	30.25	1.1909	180	301	3	A13030.25		
	30.50	1.2008	180	301	3	A13030.5		
	30.75	1.2106	180	301	3	A13030.75		
	30.96	1.2189	180	301	3	A1301.7/32		
1.7/32	31.00	1.2205	180	301	3	A13031.0	A53031.0	A73031.0
	31.25	1.2303	180	301	3	A13031.25		
	31.50	1.2402	180	301	3	A13031.5		
	31.75	1.2500	185	306	3	A13031.75		
	31.75	1.2500	185	306	3	A1301.1/4		
1.1/4	32.00	1.2598	185	334	4	A13032.0	A53032.0	A73032.0
	32.50	1.2795	185	334	4	A13032.5		
	32.54	1.2811	185	334	4	A1301.9/32		
1.9/32	33.00	1.2992	185	334	4	A13033.0	A53033.0	
	33.34	1.3126	185	334	4	A1301.5/16		
1.5/16	33.50	1.3189	185	334	4	A13033.5		
	34.00	1.3386	190	339	4	A13034.0		
	34.13	1.3437	190	339	4	A1301.11/32		
1.11/32	34.50	1.3583	190	339	4	A13034.5		
	34.93	1.3752	190	339	4	A1301.3/8		
	35.00	1.3780	190	339	4	A13035.0	A53035.0	
1.3/8	35.50	1.3976	190	339	4	A13035.5		
	35.72	1.4063	195	344	4	A1301.13/32		
	36.00	1.4173	195	344	4	A13036.0		
1.13/32	36.50	1.4370	195	344	4	A13036.5		
	36.51	1.4374	195	344	4	A1301.7/16		
	37.00	1.4567	195	344	4	A13037.0		
	37.50	1.4764	195	344	4	A13037.5		
1.7/16	38.00	1.4961	200	349	4	A13038.0		
	38.10	1.5000	200	349	4	A1301.1/2		
	38.50	1.5157	200	349	4	A13038.5		
	39.00	1.5354	200	349	4	A13039.0		
	39.50	1.5551	200	349	4	A13039.5		
1.9/16	39.69	1.5626	200	349	4	A1301.9/16		
	40.00	1.5748	200	349	4	A13040.0	A53040.0	
	40.50	1.5945	205	354	4	A13040.5		
	41.00	1.6142	205	354	4	A13041.0		
	41.28	1.6252	205	354	4	A1301.5/8		
1.5/8	41.50	1.6339	205	354	4	A13041.5		

d_1 $\varnothing h_8$ Inch	d_1 $\varnothing h_8$ mm	d_1 decimal Inch	l_2 mm	l_1 mm	MK	A130	A530	A730
	42.00	1.6535	205	354	4	A13042.0		
	42.50	1.6732	205	354	4	A13042.5		
1.11/16	42.86	1.6874	210	359	4	A1301.11/16		
	43.00	1.6929	210	359	4	A13043.0		
	43.50	1.7126	210	359	4	A13043.5		
	44.00	1.7323	210	359	4	A13044.0		
1.3/4	44.45	1.7500	210	359	4	A1301.3/4		
	44.50	1.7520	210	359	4	A13044.5		
	45.00	1.7717	210	359	4	A13045.0		
	45.50	1.7913	215	364	4	A13045.5		
	46.00	1.8110	215	364	4	A13046.0		
	46.50	1.8307	215	364	4	A13046.5		
	47.00	1.8504	215	364	4	A13047.0		
	47.50	1.8701	215	364	4	A13047.5		
	48.00	1.8898	220	369	4	A13048.0		
	48.50	1.9094	220	369	4	A13048.5		
	49.00	1.9291	220	369	4	A13049.0		
	49.50	1.9488	220	369	4	A13049.5		
	50.00	1.9685	220	369	4	A13050.0		
2"	50.80	2.0000	225	374	4	A1302		

A166

- Punta attacco codolo conico morse con placchetta brasata in MD affilatura a 4 facce
- Spiralbohrer, Morsekegel mit gelöteter HM-Schneide
- Spiraalboor met morseconus en 4-vlaks geslepen HM punt
- Foret queue cône morse avec partie carbure rectifiée et brasée sur 4 facettes

A166	▪	3.1	3.2	3.3	3.4																
	•	1.1	1.2	1.3	1.4	1.5	1.6	2.1	2.2	2.3	4.1	4.2	4.3	5.1	5.2	5.3	6.1	6.2	6.3	6.4	7.1
		7.2	7.3	7.4	8.2	9.1															

A166

HSS
HM

DIN
345

4XD

118°

ST

N



d_1 \varnothing_{h_8} mm	d_1 decimal Inch	l_2 mm	l_1 mm	MK	A166
10.00	0.3937	87	168	1	A16610.0
10.50	0.4134	87	168	1	A16610.5
11.00	0.4331	94	175	1	A16611.0
11.50	0.4528	94	175	1	A16611.5
12.00	0.4724	101	182	1	A16612.0
13.00	0.5118	101	182	1	A16613.0
13.50	0.5315	108	189	1	A16613.5
14.00	0.5512	108	189	1	A16614.0
15.00	0.5906	114	212	2	A16615.0
16.00	0.6299	120	218	2	A16616.0
17.00	0.6693	125	223	2	A16617.0
17.50	0.6890	130	228	2	A16617.5
18.00	0.7087	130	228	2	A16618.0
19.00	0.7480	135	233	2	A16619.0
20.00	0.7874	140	238	2	A16620.0
21.00	0.8268	145	243	2	A16621.0
22.00	0.8661	150	248	2	A16622.0
22.50	0.8858	155	253	2	A16622.5
23.00	0.9055	155	253	2	A16623.0
24.00	0.9449	160	281	3	A16624.0
25.00	0.9843	160	281	3	A16625.0
26.00	1.0236	165	286	3	A16626.0
27.00	1.0630	170	291	3	A16627.0
28.00	1.1024	170	291	3	A16628.0
29.00	1.1417	175	296	3	A16629.0
30.00	1.1811	175	296	3	A16630.0
32.00	1.2598	185	334	4	A16632.0
33.00	1.2992	185	334	4	A16633.0

A350

- Punta serie lunga attacco conico
- Langer MK Spiralbohrer
- Spiraalboor, lang
- Foret série longue

A350	▪	1.1	1.2																		
	•	1.3	1.4	1.5	1.6	2.1	2.2	2.3	3.1	3.2	3.3	3.4	4.1	4.2	4.3	5.1	5.2	5.3	6.1	6.2	6.3
		6.4	7.1	7.2	7.3	7.4	8.1	8.2	8.3	9.1											

A350 HSS DIN 341 6XD 118° ST N

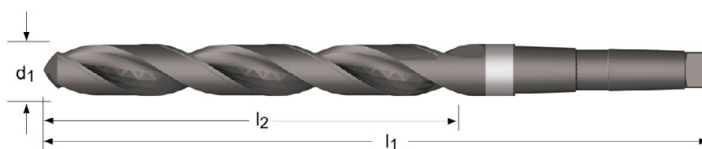

d_1 $\varnothing h_8$ mm	d_1 decimal Inch	l_2 mm	l_1 mm	MK	A350
5.00	0.1969	74	155	1	A3505.0
5.50	0.2165	80	161	1	A3505.5
6.00	0.2362	80	161	1	A3506.0
6.70	0.2638	86	167	1	A3506.7
6.80	0.2677	93	174	1	A3506.8
7.00	0.2756	93	174	1	A3507.0
7.50	0.2953	93	174	1	A3507.5
8.00	0.3150	100	181	1	A3508.0
8.40	0.3307	100	181	1	A3508.4
8.50	0.3346	100	181	1	A3508.5
8.75	0.3445	107	188	1	A3508.75
9.00	0.3543	107	188	1	A3509.0
9.50	0.3740	107	188	1	A3509.5
9.80	0.3858	116	197	1	A3509.8
10.00	0.3937	116	197	1	A35010.0
10.20	0.4016	116	197	1	A35010.2
10.50	0.4134	116	197	1	A35010.5
10.70	0.4213	125	206	1	A35010.7
11.00	0.4331	125	206	1	A35011.0
11.50	0.4528	125	206	1	A35011.5
11.75	0.4626	125	206	1	A35011.75
11.80	0.4646	125	206	1	A35011.8
12.00	0.4724	134	215	1	A35012.0
12.50	0.4921	134	215	1	A35012.5
13.00	0.5118	134	215	1	A35013.0
13.50	0.5315	142	223	1	A35013.5
14.00	0.5512	142	223	1	A35014.0
14.25	0.5610	147	245	2	A35014.25
14.50	0.5709	147	245	2	A35014.5
14.75	0.5807	147	245	2	A35014.75
15.00	0.5906	147	245	2	A35015.0
15.25	0.6004	153	251	2	A35015.25
15.50	0.6102	153	251	2	A35015.5
15.75	0.6201	153	251	2	A35015.75

d_1 $\varnothing h_8$ mm	d_1 decimal Inch	l_2 mm	l_1 mm	MK	A350
16.00	0.6299	153	251	2	A35016.0
16.25	0.6398	159	257	2	A35016.25
16.50	0.6496	159	257	2	A35016.5
16.75	0.6594	159	257	2	A35016.75
17.00	0.6693	159	257	2	A35017.0
17.25	0.6791	165	263	2	A35017.25
17.50	0.6890	165	263	2	A35017.5
18.00	0.7087	165	263	2	A35018.0
18.50	0.7283	171	269	2	A35018.5
19.00	0.7480	171	269	2	A35019.0
19.50	0.7677	177	275	2	A35019.5
19.75	0.7776	177	275	2	A35019.75
20.00	0.7874	177	275	2	A35020.0
20.25	0.7972	184	282	2	A35020.25
20.50	0.8071	184	282	2	A35020.5
21.00	0.8268	184	282	2	A35021.0
21.50	0.8465	191	289	2	A35021.5
22.00	0.8661	191	289	2	A35022.0
22.50	0.8858	198	296	2	A35022.5
23.00	0.9055	198	296	2	A35023.0
23.50	0.9252	198	319	3	A35023.5
24.00	0.9449	206	327	3	A35024.0
24.50	0.9646	206	327	3	A35024.5
25.00	0.9843	206	327	3	A35025.0
25.50	1.0039	214	335	3	A35025.5
26.00	1.0236	214	335	3	A35026.0
26.50	1.0433	214	335	3	A35026.5
27.00	1.0630	222	343	3	A35027.0
27.50	1.0827	222	343	3	A35027.5
28.00	1.1024	222	343	3	A35028.0
29.00	1.1417	230	351	3	A35029.0
30.00	1.1811	230	351	3	A35030.0
30.50	1.2008	239	360	3	A35030.5
31.00	1.2205	239	360	3	A35031.0
31.50	1.2402	239	360	3	A35031.5
32.00	1.2598	248	397	4	A35032.0
33.00	1.2992	248	397	4	A35033.0
34.00	1.3386	257	406	4	A35034.0
35.00	1.3780	257	406	4	A35035.0
36.00	1.4173	267	416	4	A35036.0
37.00	1.4567	267	416	4	A35037.0
38.00	1.4961	277	426	4	A35038.0
39.00	1.5354	277	426	4	A35039.0
40.00	1.5748	277	426	4	A35040.0
41.00	1.6142	287	436	4	A35041.0
42.00	1.6535	287	436	4	A35042.0
43.00	1.6929	298	447	4	A35043.0
44.00	1.7323	298	447	4	A35044.0
45.00	1.7717	298	447	4	A35045.0
46.00	1.8110	310	459	4	A35046.0
47.00	1.8504	310	459	4	A35047.0
48.00	1.8898	321	470	4	A35048.0
50.00	1.9685	321	470	4	A35050.0

- ## A345
- Punta serie extra lunga attacco conico
 - Spiralbohrer MK, extra lang
 - Extra lange spiraalboor met morseconus
 - Foret queue cône morse - Extra long

A345	▪	1.1	1.2																		
	•	1.3	1.4	1.5	1.6	2.1	2.2	2.3	3.1	3.2	3.3	3.4	4.1	4.2	4.3	5.1	5.2	5.3	6.1	6.2	6.3
		6.4	7.1	7.2	7.3	7.4	8.1	8.2	8.3	9.1											

A345
HSS
DIN 1870/1
10XD
118°
ST

N

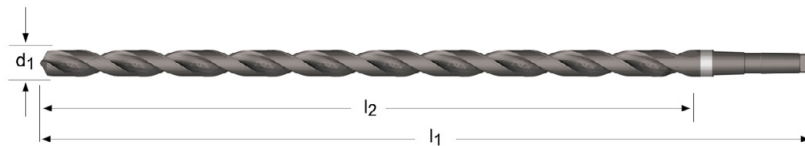

d_1 \varnothing_{h_8} Inch	d_1 \varnothing_{h_8} mm	d_1 decimal Inch	l_2 mm	l_1 mm	MK	A345
	8.00	0.3150	165	265	1	A3458.0
	8.50	0.3346	165	265	1	A3458.5
	9.00	0.3543	175	275	1	A3459.0
	9.50	0.3740	175	275	1	A3459.5
3/8	9.52	0.3748	185	285	1	A3453/8
	10.00	0.3937	185	285	1	A34510.0
13/32	10.32	0.4063	185	285	1	A34513/32
	10.50	0.4134	185	285	1	A34510.5
	11.00	0.4331	195	300	1	A34511.0
7/16	11.11	0.4374	195	300	1	A3457/16
	11.50	0.4528	195	300	1	A34511.5
29/64	11.51	0.4531	205	310	1	A34529/64
	12.00	0.4724	205	310	1	A34512.0
	12.50	0.4921	205	310	1	A34512.5
1/2	12.70	0.5000	205	310	1	A3451/2
	13.00	0.5118	205	310	1	A34513.0
17/32	13.49	0.5311	220	325	1	A34517/32
	13.50	0.5315	220	325	1	A34513.5
	14.00	0.5512	220	325	1	A34514.0
9/16	14.29	0.5626	220	340	2	A3459/16
37/64	14.68	0.5780	220	340	2	A34537/64
	15.00	0.5906	220	340	2	A34515.0
39/64	15.48	0.6094	230	355	2	A34539/64
	15.50	0.6102	230	355	2	A34515.5
5/8	15.88	0.6252	230	355	2	A3455/8
	16.00	0.6299	230	355	2	A34516.0
41/64	16.27	0.6406	230	355	2	A34541/64
	16.50	0.6496	230	355	2	A34516.5
21/32	16.67	0.6563	230	355	2	A34521/32
	17.00	0.6693	230	355	2	A34517.0
11/16	17.46	0.6874	245	370	2	A34511/16
	17.50	0.6890	245	370	2	A34517.5

d_1 $\varnothing h_8$ Inch	d_1 $\varnothing h_8$ mm	d_1 decimal Inch	l_2 mm	l_1 mm	MK	A345	
3/4	18.00	0.7087	245	370	2	A34518.0	
	18.50	0.7283	245	370	2	A34518.5	
	19.00	0.7480	245	370	2	A34519.0	
	19.05	0.7500	260	385	2	A3453/4	
	19.50	0.7677	260	385	2	A34519.5	
	20.00	0.7874	260	385	2	A34520.0	
	20.50	0.8071	260	385	2	A34520.5	
	21.00	0.8268	260	385	2	A34521.0	
	21.50	0.8465	270	405	2	A34521.5	
	22.00	0.8661	270	405	2	A34522.0	
7/8	22.22	0.8748	270	405	2	A3457/8	
	22.50	0.8858	270	405	3	A34522.5	
	23.00	0.9055	270	405	3	A34523.0	
	23.50	0.9252	270	425	3	A34523.5	
	24.00	0.9449	290	440	3	A34524.0	
	24.50	0.9646	290	440	3	A34524.5	
	25.00	0.9843	290	440	3	A34525.0	
	25.40	1.0000	290	440	3	A3451 ³⁾	
1"	25.50	1.0039	290	440	3	A34525.5 ³⁾	
	26.00	1.0236	290	440	3	A34526.0 ³⁾	
	26.50	1.0433	290	440	3	A34526.5 ³⁾	
	27.00	1.0630	305	460	3	A34527.0 ³⁾	
	28.00	1.1024	305	460	3	A34528.0 ³⁾	
	29.00	1.1417	305	460	3	A34529.0 ³⁾	
	30.00	1.1811	305	460	3	A34530.0 ³⁾	
	1.1/4	31.75	1.2500	320	480	3	A3451.1/4 ³⁾
		31.00	1.2205	320	480	3	A34531.0 ³⁾
		32.00	1.2598	320	505	4	A34532.0 ³⁾
33.00		1.2992	320	505	4	A34533.0 ³⁾	
34.00		1.3386	340	530	4	A34534.0 ³⁾	
35.00		1.3780	340	530	4	A34535.0 ³⁾	
36.00		1.4173	340	530	4	A34536.0 ³⁾	
37.00		1.4567	340	530	4	A34537.0 ³⁾	
38.00		1.4961	360	555	4	A34538.0 ³⁾	
1.1/2		38.10	1.5000	360	555	4	A3451.1/2 ³⁾
	39.00	1.5354	360	555	4	A34539.0 ³⁾	
	40.00	1.5748	360	555	4	A34540.0 ³⁾	

A951 • Punta serie extra lunga attacco conico
• Spiralbohrer MK, extra lang

A952 • Extra lange spiraalboor met morseconus
• Foret queue cône morse - Extra long

A951; A952	▪	1.1	1.2	1.3															
	•	1.4	1.5	1.6	2.1	2.2	2.3	3.1	3.2	3.3	3.4	4.1	4.2	4.3	5.1	5.2	5.3	6.1	6.2
		6.3	6.4	7.1	7.2	7.3	7.4	8.1	8.2	8.3	9.1								

A951	HSS	DIN 1870/1	15XD	130°	ST		W			
A952	HSS	DIN 1870/2	20XD	130°	ST		W			

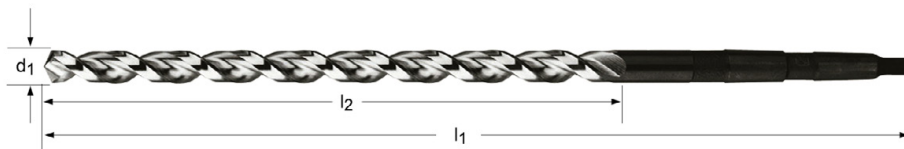

d ₁ Øh ₈ mm	d ₁ decimal Inch	l ₂ mm	l ₁ mm	MK	A951	A952
8.00	0.3150	210	330	1		A9528.0
8.50	0.3346	210	330	1		A9528.5
9.00	0.3543	220	345	1		A9529.0
10.00	0.3937	185	285	1	A95110.0	
10.00	0.3937	235	360	1		A95210.0
10.50	0.4134	235	360	1		A95210.5
11.00	0.4331	195	300	1	A95111.0	
11.00	0.4331	250	375	1		A95211.0
11.50	0.4528	250	375	1		A95211.5
12.00	0.4724	205	310	1	A95112.0	
12.00	0.4724	260	395	1		A95212.0
12.50	0.4921	205	310	1	A95112.5	
12.50	0.4921	260	395	1		A95212.5
13.00	0.5118	205	310	1	A95113.0	
13.00	0.5118	260	395	1		A95213.0
13.50	0.5315	220	325	1	A95113.5	
13.50	0.5315	275	410	1		A95213.5
14.00	0.5512	220	325	1	A95114.0	
14.00	0.5512	275	410	1		A95214.0
14.50	0.5709	220	340	2	A95114.5 ⁵⁾	
14.50	0.5709	275	425	2		A95214.5 ⁶⁾
15.00	0.5906	220	340	2	A95115.0 ⁵⁾	
15.00	0.5906	275	425	2		A95215.0 ⁶⁾
15.50	0.6102	230	355	2	A95115.5 ⁵⁾	
15.50	0.6102	295	445	2		A95215.5 ⁶⁾
16.00	0.6299	230	355	2	A95116.0 ⁵⁾	
16.00	0.6299	295	445	2		A95216.0 ⁶⁾
16.50	0.6496	230	355	2	A95116.5 ⁵⁾	

⁵⁾ < 15xD

⁶⁾ < 20xD

d_1 $\varnothing h_8$ mm	d_1 decimal Inch	l_2 mm	l_1 mm	MK	A951	A952
16.50	0.6496	295	445	2		A95216.5 ⁶⁾
17.00	0.6693	230	355	2	A95117.0 ⁵⁾	A95217.0 ⁶⁾
17.00	0.6693	295	445	2		A95217.0 ⁶⁾
17.50	0.6890	245	370	2	A95117.5 ⁵⁾	
17.50	0.6890	310	465	2		A95217.5 ⁶⁾
18.00	0.7087	245	370	2	A95118.0 ⁵⁾	
18.00	0.7087	310	465	2		A95218.0 ⁶⁾
18.50	0.7283	245	370	2	A95118.5 ⁵⁾	
18.50	0.7283	310	465	2		A95218.5 ⁶⁾
19.00	0.7480	245	370	2	A95119.0 ⁵⁾	
19.00	0.7480	310	465	2		A95219.0 ⁶⁾
19.50	0.7677	260	385	2	A95119.5 ⁵⁾	
19.50	0.7677	325	490	2		A95219.5 ⁶⁾
20.00	0.7874	260	385	2	A95120.0 ⁵⁾	
20.00	0.7874	325	490	2		A95220.0 ⁶⁾
21.00	0.8268	260	385	2	A95121.0 ⁵⁾	
21.00	0.8268	325	490	2		A95221.0 ⁶⁾
22.00	0.8661	270	405	2	A95122.0 ⁵⁾	
22.00	0.8661	345	515	2		A95222.0 ⁶⁾
23.00	0.9055	270	405	2	A95123.0 ⁵⁾	
23.00	0.9055	345	515	2		A95223.0 ⁶⁾
24.00	0.9449	290	440	3	A95124.0 ⁵⁾	
24.00	0.9449	365	555	3		A95224.0 ⁶⁾
25.00	0.9843	290	440	3	A95125.0 ⁵⁾	
25.00	0.9843	365	555	3		A95225.0 ⁶⁾
26.00	1.0236	290	440	3	A95126.0 ⁵⁾	
26.00	1.0236	365	555	3		A95226.0 ⁶⁾
27.00	1.0630	305	460	3	A95127.0 ⁵⁾	
27.00	1.0630	385	580	3		A95227.0 ⁶⁾
28.00	1.1024	305	460	3	A95128.0 ⁵⁾	
28.00	1.1024	385	580	3		A95228.0 ⁶⁾
29.00	1.1417	305	460	3	A95129.0 ⁵⁾	
29.00	1.1417	385	580	3		A95229.0 ⁶⁾
30.00	1.1811	305	460	3	A95130.0 ⁵⁾	
30.00	1.1811	385	580	3		A95230.0 ⁶⁾
31.00	1.2205	410	610	3		A95231.0 ⁶⁾
32.00	1.2598	410	635	4		A95232.0 ⁶⁾
33.00	1.2992	410	635	4		A95233.0 ⁶⁾
34.00	1.3386	430	665	4		A95234.0 ⁶⁾
35.00	1.3780	430	665	4		A95235.0 ⁶⁾
38.00	1.4961	460	695	4		A95238.0 ⁶⁾
40.00	1.5748	460	695	4		A95240.0 ⁶⁾

⁵⁾ < 15xD

⁶⁾ < 20xD

- A400**
- Punta a gradino con eliche indipendenti - 90°
 - Mehrfasen-Stufenbohrer, zylinderschaft - 90°
 - Meerfasenboor - 90°
 - Foret étagé - 90°

A400	▪	1.1	1.2	1.3	1.4	3.1	3.2															
		•	1.5	1.6	2.1	2.2	2.3	3.3	3.4	4.1	4.2	4.3	5.1	5.2	5.3	6.1	6.2	6.3	6.4	7.1	7.2	7.3
		7.4	8.1																			

A400 HSS DIN 8374 4XD 118° ST N 90°



M	d_1 Ø mm	d_1 decimal Inch	l_2 mm	l_1 mm	l_3 mm	d_2 Ø mm	A400
M3	3.20	0.1260	57	93	9	6	A400M3
M4	4.30	0.1693	75	117	11	8	A400M4
M5	5.30	0.2087	87	133	13	10	A400M5
M6	6.40	0.2520	94	142	15	11.5	A400M6
M8	8.40	0.3307	114	169	19	15	A400M8
M10	10.50	0.4134	135	198	23	19	A400M10

A402

- Punta a gradino con eliche indipendenti - 180°
- Mehrfasen-Stufenbohrer, zylinderschaft - 180°
- Meerfasenboor - 180°
- Foret étagé - 180°

A402	▪	1.1	1.2	1.3	1.4	3.1	3.2															
	•	1.5	1.6	2.1	2.2	2.3	3.3	3.4	4.1	4.2	4.3	5.1	5.2	5.3	6.1	6.2	6.3	6.4	7.1	7.2	7.3	
		7.4	8.1																			

A402 HSS DIN 8376 4XD 118° ST N 180°



M	d_1 Ø mm	d_1 decimal Inch	l_2 mm	l_1 mm	l_3 mm	d_2 Ø mm	A402
M3	3.40	0.1339	57	93	9	6	A402M3
M4	4.50	0.1772	75	117	11	8	A402M4
M5	5.50	0.2165	87	133	13	10	A402M5
M6	6.60	0.2598	94	142	15	11	A402M6
M8	9.00	0.3543	114	169	19	15	A402M8
M10	11.00	0.4331	130	191	23	18	A402M10

A405

- Punta a gradino con eliche indipendenti con codolo conico Morse - 180°
- Mehrfasen-Stufenbohrer, MK-Schaft - 180°
- Meerfasenboor met MC - 180°
- Queue cone morse foret étagé - 180°

A405	▪	1.1	1.2	1.3	1.4	3.1	3.2														
	•	1.5	1.6	2.1	2.2	2.3	3.3	3.4	4.1	4.2	4.3	5.1	5.2	5.3	6.1	6.2	6.3	6.4	7.1	7.2	7.3
		7.4	8.1																		

A405 HSS DIN 8377 4XD 118° ST N 180°

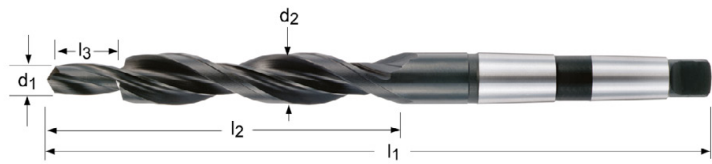

M	d ₁ ∅ mm	d ₁ decimal Inch	l ₂ mm	l ₁ mm	l ₃ mm	d ₂ ∅ mm	MK	A405
M6	6.60	0.2598	94	175	15	11	1	A405M6
M8	9.00	0.3543	114	212	19	15	2	A405M8
M10	11.00	0.4331	130	228	23	18	2	A405M10
M12	13.50	0.5315	140	238	27	20	2	A405M12
M14	15.50	0.6102	160	281	31	24	3	A405M14
M16	17.50	0.6890	165	286	35	26	3	A405M16
M18	20.00	0.7874	175	296	39	30	3	A405M18

A412

- Punta a gradino
- Stufenbohrer
- Trapboor
- Foret étagé

A412	▪	1.1	1.2	1.3	1.4	2.1	3.1	3.2														
	•	1.5	1.6	2.2	2.3	3.3	3.4	4.1	4.2	4.3	5.1	5.2	5.3	6.1	6.2	6.3	6.4	7.1	7.2	7.3	7.4	
		8.1																				

A412 HSS DORMER 2.5XD 118° ST

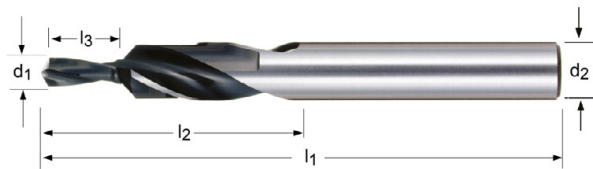

M	d_1 Ø mm	d_1 decimal Inch	l_2 mm	l_1 mm	l_3 mm	d_2 Ø mm	A412
M3	3.40	0.1339	31	70	9	6.6	A412M3
M4	4.50	0.1772	40	84	11	9	A412M4
M5	5.50	0.2165	47	95	13	11	A412M5
M6	6.60	0.2598	51	102	15	13	A412M6
M8	9.00	0.3543	62	123	19	17.2	A412M8
M10	11.00	0.4331	70	141	23	21.5	A412M10

A413

- Punta a gradino
- Stufenbohrer
- Trapboor
- Foret étagé

A413	▪	1.1	1.2	1.3	1.4	2.1	3.1	3.2													
	•	1.5	1.6	2.2	2.3	3.3	3.4	4.1	4.2	4.3	5.1	5.2	5.3	6.1	6.2	6.3	6.4	7.1	7.2	7.3	7.4
		8.1																			

A413 HSS DORMER 2.5XD 118° ST   

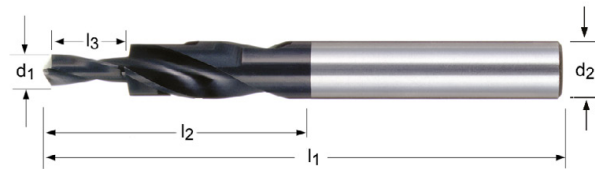

M	d ₁ Ø mm	d ₁ decimal Inch	l ₂ mm	l ₁ mm	l ₃ mm	d ₂ Ø mm	A413
M3	3.40	0.1339	28	66	9	6	A413M3
M4	4.50	0.1772	37	79	11	8	A413M4
M5	5.50	0.2165	43	89	13	10	A413M5
M6	6.60	0.2598	47	95	15	11	A413M6
M8	9.00	0.3543	56	111	19	15	A413M8
M10	11.00	0.4331	62	123	23	18	A413M10

- A200** • Punta da centro - 60°
A205 • Zentrierbohrer - 60°
A206 • Centerboor - 60°
A266 • Foret à centrer - 60°

A200; A205; A206; A266	▪	1.1	1.2	1.3	1.4	3.1	3.2											
	•	1.5	1.6	2.1	2.2	2.3	3.3	3.4	4.1	4.2	4.3	5.1	5.2	5.3	6.1	6.2		
		6.3	6.4	7.1	7.2	7.3	7.4	8.1	8.2	8.3	9.1							

A200	HSS	DIN 333A	1XD	118°								
A205	HSS	DIN 333A	1XD	118°	TiN							
A206	HSS-E	DIN 333A	1XD	118°								
A266	HSS-E	DIN 333A	1XD	118°	TiAIN							

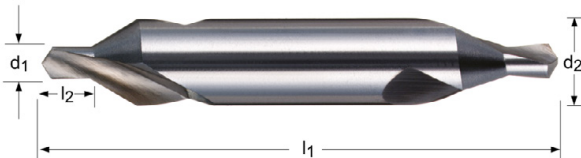

A200	A205	A206	A266
0.50 - 12.50	1.00 - 5.00	1.00 - 5.00	1.00 - 5.00

d ₁ ∅ mm	d ₁ decimal Inch	l ₂ max/min mm	l ₁ mm	d ₂ ∅ mm	A200	A205	A206	A266
0.50	0.0197	0.9 - 0.6	25	3.15	A200.5X3.15 ⁷⁾			
0.80	0.0315	1.3 - 1.0	25	3.15	A200.8X3.15 ⁷⁾			
1.00	0.0394	1.7 - 1.3	31	3.15	A2001.0X3.15	A2051.0X3.15	A2061.0X3.15	A2661.0X3.15
1.25	0.0492	2.0 - 1.6	31	3.15	A2001.25X3.15	A2051.25X3.15	A2061.25X3.15	A2661.25X3.15
1.60	0.0630	2.6 - 2.0	35	4.00	A2001.6X4.0	A2051.6X4.0	A2061.6X4.0	A2661.6X4.0
2.00	0.0787	3.1 - 2.5	40	5.00	A2002.0X5.0	A2052.0X5.0	A2062.0X5.0	A2662.0X5.0
2.50	0.0984	3.8 - 3.1	45	6.30	A2002.5X6.3	A2052.5X6.3	A2062.5X6.3	A2662.5X6.3
3.15	0.1240	4.6 - 3.9	50	8.00	A2003.15X8.0	A2053.15X8.0	A2063.15X8.0	A2663.15X8.0
4.00	0.1575	5.9 - 5.0	55	10.00	A2004.0X10.0	A2054.0X10.0	A2064.0X10.0	A2664.0X10.0
5.00	0.1969	7.2 - 6.3	63	12.50	A2005.0X12.5	A2055.0X12.5	A2065.0X12.5	A2665.0X12.5
6.30	0.2480	8.9 - 8.0	71	16.00	A2006.3X16.0			
8.00	0.3150	11.1 - 10.1	80	20.00	A2008.0X20.0			
10.00	0.3937	13.8 - 12.8	100	25.00	A20010.0X25.0			
12.50	0.4921	17.5 - 16.5	125	31.50	A20012.5X31.5			

⁷⁾ solamente con una sola estremità / nur einseitig / Eenzijdig / Une pointe seulement

A210

- Punta da centro
- Zentrierbohrer
- Centerboor
- Foret à centrer

Forma a raggio
mit Radius
Radius uitvoering
Chanfrein à rayon

A210	▪	1.1	1.2	1.3	1.4	3.1	3.2														
	•	1.5	1.6	2.1	2.2	2.3	3.3	3.4	4.1	4.2	4.3	5.1	5.2	5.3	6.1	6.2	6.3	6.4	7.1	7.2	7.3
		7.4	8.1	8.2	8.3	9.1															

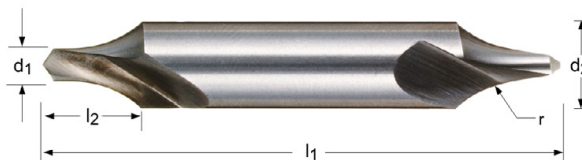

d_1 Ø mm	d_1 decimal Inch	l_2 max/min mm	l_1 mm	r max/min mm	d_2 Ø mm	A210
0.50	0.0197	2.6 - 2.3	25.0	2.50 - 2.00	3.15	A210.5X3.15 ⁷⁾
0.80	0.0315	2.9 - 2.6	25.0	3.15 - 2.50	3.15	A210.8X3.15 ⁷⁾
1.00	0.0394	3.3 - 3.0	31.0	3.65 - 2.90	3.15	A2101.0X3.15
1.25	0.0492	3.6 - 3.3	31.0	3.95 - 3.15	3.15	A2101.25X3.15
1.60	0.0630	4.7 - 4.2	35.0	5.00 - 4.00	4.00	A2101.6X4.0
2.00	0.0787	5.4 - 5.0	40.0	6.25 - 5.00	5.00	A2102.0X5.0
2.50	0.0984	6.8 - 6.3	45.0	7.88 - 6.30	6.30	A2102.5X6.3
3.15	0.1240	8.5 - 8.0	50.0	10.00 - 8.00	8.00	A2103.15X8.0
4.00	0.1575	10.6 - 10.0	55.0	12.50 - 10.00	10.00	A2104.0X10.0
5.00	0.1969	13.1 - 12.5	63.0	15.63 - 12.50	12.50	A2105.0X12.5
6.30	0.2480	16.6 - 16.0	71.0	20.00 - 16.00	16.00	A2106.3X16.0
8.00	0.3150	20.7 - 20.0	80.0	25.00 - 20.00	20.00	A2108.0X20.0
10.00	0.3937	25.7 - 25.0	100.0	31.25 - 25.00	25.00	A21010.0X25.0

A201

- Punta da centro - 60°
- Zentrierbohrer - 60°
- Centerboor - 60°
- Foret à centrer - 60°

A201	▪	1.1	1.2	1.3	1.4	3.1	3.2														
	•	1.5	1.6	2.1	2.2	2.3	3.3	3.4	4.1	4.2	4.3	5.1	5.2	5.3	6.1	6.2	6.3	6.4	7.1	7.2	7.3
		7.4	8.1	8.2	8.3	9.1															

A201 HSS DORMER 1XD 122° 60°

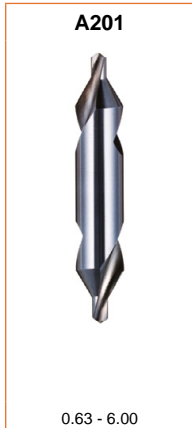
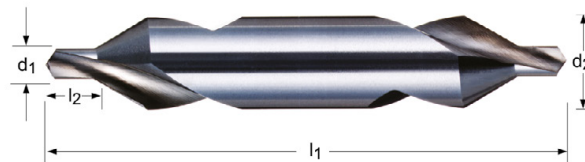

d ₁ Ø mm	d ₁ decimal Inch	l ₂ max/min mm	l ₁ mm	d ₂ Ø mm	A201
0.63	0.0248	1.2 - 0.9	20	3.15	A201.63X3.15 ⁷⁾
0.75	0.0295	1.3 - 1.0	35	3.50	A201.75X3.5
1.00	0.0394	2.1 - 1.5	35	4.00	A2011.0X4.0
1.50	0.0591	2.8 - 2.0	40	5.00	A2011.5X5.0
1.60	0.0630	2.4 - 2.0	40	5.00	A2011.6X5.0
2.00	0.0787	4.0 - 3.0	45	6.00	A2012.0X6.0
2.00	0.0787	2.9 - 2.5	45	6.30	A2012.0X6.3
2.50	0.0984	4.5 - 3.5	50	8.00	A2012.5X8.0
3.00	0.1181	4.4 - 3.9	50	8.00	A2013.0X8.0
3.00	0.1181	5.0 - 4.0	56	10.00	A2013.0X10.0
3.15	0.1240	4.4 - 3.9	56	10.00	A2013.15X10.0
4.00	0.1575	6.2 - 5.0	66	12.00	A2014.0X12.0
5.00	0.1969	7.7 - 6.5	78	14.00	A2015.0X14.0
6.00	0.2362	9.2 - 8.0	90	18.00	A2016.0X18.0

⁷⁾ solamente con una sola estremità / nur einseitig / Eenzijdig / Une pointe seulement

A225

- Punta da centro - 60°
- Zentrierbohrer - 60°
- Centerboor - 60°
- Foret à centrer - 60°

A225	▪	1.1	1.2	1.3	1.4	3.1	3.2														
	•	1.5	1.6	2.1	2.2	2.3	3.3	3.4	4.1	4.2	4.3	5.1	5.2	5.3	6.1	6.2	6.3	6.4	7.1	7.2	7.3
		7.4	8.1	8.2	8.3	9.1															

A225 HSS BS 328 1XD 120° 60° A296 136

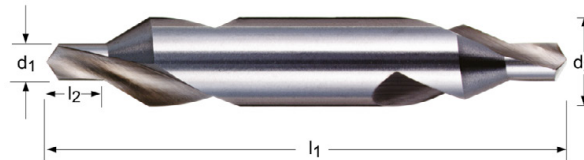

Nr.	d ₁ Ø Inch	d ₁ decimal Inch	l ₂ max/min Inch	l ₁ Inch	d ₂ Ø Inch	A225
BS1	3/64	0.0469	5/64 - 1/16	1.1/2	1/8	A225BS1
BS2	1/16	0.0625	3/32 - 5/64	1.3/4	3/16	A225BS2
BS3	3/32	0.0938	5/32 - 1/8	2"	1/4	A225BS3
BS4	1/8	0.1250	3/16 - 5/32	2.1/4	5/16	A225BS4
BS5	3/16	0.1875	9/32 - 1/4	2.1/2	7/16	A225BS5
BS5A	7/32	0.2188	5/16 - 9/32	2.3/4	1/2	A225BS5A
BS6	1/4	0.2500	3/8 - 5/16	3"	5/8	A225BS6
BS7	5/16	0.3125	15/32 - 13/32	3.1/2	3/4	A225BS7

A237

- Punta da centro - 60°
- Zentrierbohrer - 60°
- Centerboor - 60°
- Foret à centrer - 60°

Attacco con piano
 Schaft mit Spannfläche
 Schacht met spanvlak
 Queue avec plat

A237	▪	1.1	1.2	1.3	1.4	3.1	3.2														
	•	1.5	1.6	2.1	2.2	2.3	3.3	3.4	4.1	4.2	4.3	5.1	5.2	5.3	6.1	6.2	6.3	6.4	7.1	7.2	7.3
		7.4	8.1	8.2	8.3	9.1															

A237 HSS-E **DIN 333A** 1XD **118°**

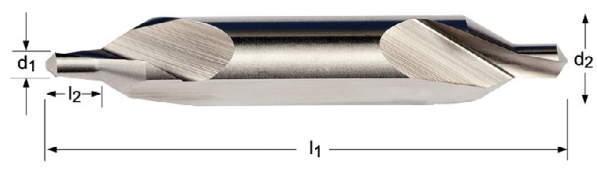

d ₁ Ø mm	d ₁ decimal Inch	l ₂ max/min mm	l ₁ mm	d ₂ Ø mm	d ₄ max/min mm	A237
1.60	0.0630	2.6 - 2.0	35	4.00	3.25 - 3.15	A2371.6X4.0
2.00	0.0787	3.1 - 2.5	40	5.00	4.20 - 4.10	A2372.0X5.0
2.50	0.0984	3.8 - 3.1	45	6.30	5.35 - 5.25	A2372.5X6.3
3.15	0.1240	4.6 - 3.9	50	8.00	6.95 - 6.85	A2373.15X8.0
4.00	0.1575	5.9 - 5.0	55	10.00	8.40 - 8.30	A2374.0X10.0
5.00	0.1969	7.2 - 6.3	63	12.50	10.95 - 10.85	A2375.0X12.5
6.30	0.2480	8.9 - 8.0	71	16.00	14.00 - 13.90	A2376.3X16.0
8.00	0.3150	11.1 - 10.1	80	20.00	17.90 - 17.80	A2378.0X20.0
10.00	0.3937	13.8 - 12.8	100	25.00	22.50 - 22.40	A23710.0X25.0

A238

- Punta da centro
- Zentrierbohrer
- Centerboor
- Foret à centrer

Forma radiale e attacco con piano
 Radius und Schaft mit Spannfläche
 Radius uitvoering en schacht met spanvlak
 Forme rayonnée et queue avec plat

A238	▪	1.1	1.2	1.3	1.4	3.1	3.2														
	•	1.5	1.6	2.1	2.2	2.3	3.3	3.4	4.1	4.2	4.3	5.1	5.2	5.3	6.1	6.2	6.3	6.4	7.1	7.2	7.3
		7.4	8.1	8.2	8.3	9.1															

A238 HSS-E **DIN 333R** 1XD    

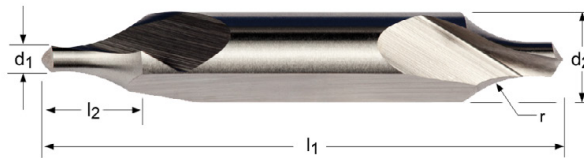

d_1 Ø mm	d_1 decimal Inch	l_2 max/min mm	l_1 mm	r max/min mm	d_2 Ø mm	d_4 max/min mm	A238
1.60	0.0630	4.7 - 4.2	35	5.00 - 4.00	4.00	3.25 - 3.15	A2381.6X4.0
2.00	0.0787	5.4 - 5.0	40	6.25 - 5.00	5.00	4.20 - 4.10	A2382.0X5.0
2.50	0.0984	6.8 - 6.3	45	7.88 - 6.30	6.30	5.35 - 5.25	A2382.5X6.3
3.15	0.1240	8.5 - 8.0	50	10.00 - 8.00	8.00	6.95 - 6.85	A2383.15X8.0
4.00	0.1575	10.6 - 10.0	55	12.50 - 10.00	10.00	8.40 - 8.30	A2384.0X10.0
5.00	0.1969	13.1 - 12.5	63	15.63 - 12.50	12.50	10.95 - 10.85	A2385.0X12.5
6.30	0.2480	16.6 - 16.0	71	20.00 - 16.00	16.00	14.00 - 13.90	A2386.3X16.0
8.00	0.3150	20.7 - 20.0	80	25.00 - 20.00	20.00	17.90 - 17.80	A2388.0X20.0

A242

- Punta da centro - 60°
- Zentrierbohrer - 60°
- Centerboor - 60°
- Foret à centrer - 60°

A242	▪	1.1	1.2	1.3	1.4	3.1	3.2														
	•	1.5	1.6	2.1	2.2	2.3	3.3	3.4	4.1	4.2	4.3	5.1	5.2	5.3	6.1	6.2	6.3	6.4	7.1	7.2	7.3
		7.4	8.1	8.2	8.3	9.1															

A242 HSS-E DORMER 1XD 118°



d_1 Ø mm	d_1 decimal Inch	l_2 max/min mm	l_1 mm	d_2 Ø mm	A242
1.00	0.0394	1.7 - 1.3	100	4.00	A2421.0X4.0
1.50	0.0591	2.6 - 2.0	100	5.00	A2421.5X5.0
2.00	0.0787	3.1 - 2.5	100	6.00	A2422.0X6.0
2.50	0.0984	3.8 - 3.1	100	8.00	A2422.5X8.0
3.00	0.1181	4.6 - 3.9	100	8.00	A2423.0X8.0
3.00	0.1181	4.6 - 3.9	100	10.00	A2423.0X10.0
4.00	0.1575	5.9 - 5.0	100	10.00	A2424.0X10.0
4.00	0.1575	5.9 - 5.0	100	12.00	A2424.0X12.0
5.00	0.1969	7.2 - 6.3	100	12.00	A2425.0X12.0

A088

- Punta serie corta, set
- Spiralbohrer, Satz
- Extra korte spiraalboor in set
- Coffrets de forets extra-court

A=Tipi in serie, B=No. punte in Set, C=diametri in Set

A=Typen in Satz, B=Anzahl, C=Durchmesser im Satz

A=Type, B=Aantal, C=Diameters

A=Types de coffrets, B=Nombre dans le coffret, C=Diamètres dans le coffret



Set	A	B	C	A088
200S	A022	24	1.0 mm - 10.5 mm x 0.5 mm + 3.3 mm, 4.2 mm, 6.8 mm, 10.2 mm	A088200S

A095

- Punta serie corta, set
- Spiralbohrer, Satz
- Spiraalboor in set
- Coffret de forets courts

A=Tipi in serie, B=No. punte in Set, C=diametri in Set

A=Typen in Satz, B=Anzahl, C=Durchmesser im Satz

A=Type, B=Aantal, C=Diameters

A=Types de coffrets, B=Nombre dans le coffret, C=Diamètres dans le coffret



Set	A	B	C	A095
18	A002	29	1/16 inch - 1/2 inch x 1/64 inch	A09518
20	A002	15	1/16 inch - 1/2 inch x 1/32 inch	A09520
200	A002	24	1.0 mm - 10.5 mm x 0.5 mm + 3.3 mm, 4.2 mm, 6.8 mm, 10.2 mm	A095200
201	A002	19	1.0 mm - 10.0 mm x 0.5 mm	A095201
202	A002	51	1.0 mm - 6.0 mm x 0.1 mm	A095202
203	A002	41	6.0 mm - 10.0 mm x 0.1 mm	A095203
204	A002	25	1.0 mm - 13.0 mm x 0.5 mm	A095204
206	A002	29	1.0 mm - 13.0 mm x 0.5 mm + 3.3 mm, 4.2 mm, 6.8 mm, 10.2 mm	A095206
209	A002	91	1.0 mm - 10.0 mm x 0.1 mm	A095209

A087

- Set Punte diametri comuni
- Kompaktes Bohrer-set
- Compacte boren set
- Coffret compact de forets

A=Tipi in serie, B=No. punte in Set, C=diametri in Set

A=Typen in Satz, B=Anzahl, C=Durchmesser im Satz

A=Type, B=Aantal, C=Diameters

A=Types de coffrets, B=Nombre dans le coffret, C=Diamètres dans le coffret



Nr.	A	B	C	A087
201	A002	19	1.0 mm - 10.0 mm x 0.5 mm	A087201

A094

- Punta serie corta, set
- Spiralbohrer, Satz
- Spiraalboor in set
- Coffret de forets courts

A=Tipi in serie, B=No. punte in Set, C=diametri in Set

A=Typen in Satz, B=Anzahl, C=Durchmesser im Satz

A=Type, B=Aantal, C=Diameters

A=Types de coffrets, B=Nombre dans le coffret, C=Diamètres dans le coffret



Set	A	B	C	A094
413	A002	13	1.5 mm - 6.5 mm x 0.5 mm + 3.3 mm, 4.2 mm	A094413
419	A002	19	1.0 mm - 10.0 mm x 0.5 mm	A094419

A089

- Punta serie corta,set
- Spiralbohrer, Satz
- Spiraalboor in set
- Coffret de forets courts

A=Tipi in serie, B=No. punte in Set, C=diametri in Set

A=Typen in Satz, B=Anzahl, C=Durchmesser im Satz

A=Type, B=Aantal, C=Diameters

A=Types de coffrets, B=Nombre dans le coffret, C=Diamètres dans le coffret



Set

Nr.	A	B	C	A089
10	A002	5	A0024.0, A0025.0, A0026.0, A0028.0, A00210.0	A08910

A099

- Espositore con punte
- Spiralbohrer Dispenser
- Toonbankdispencer
- Présentoir

A=Tipi in serie, B=No. punte in Set, C=diametri in Set

A=Typen in Satz, B=Anzahl, C=Durchmesser im Satz

A=Type, B=Aantal, C=Diameters

A=Types de coffrets, B=Nombre dans le coffret, C=Diamètres dans le coffret

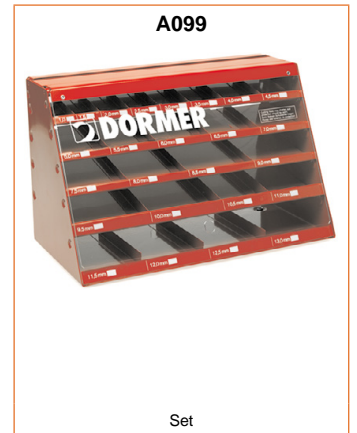

A099

Set

Set	A	B	C
F1	A002	380	5 x (13/32, 7/16, 15/32, 1/2) inch; 10 x (5/64, 7/64, 9/64, 11/64, 13/64, 15/64, 17/64, 9/32, 19/64, 5/16, 21/64, 11/32, 23/64, 3/8) inch; 20 x (1/16, 7/32, 1/4) inch; 30 x 3/32 inch; 40 x (5/32, 3/16) inch; 50 x 1/8 inch
M1	A002	340	5 x (10.50, 11.00, 11.50, 12.00, 12.50, 13.00) mm; 10 x (1.50, 2.50, 3.50, 4.50, 5.50, 6.50, 7.00, 7.50, 8.00, 8.50, 9.00, 9.50, 10.00) mm; 20 x (1.00, 5.00, 6.00) mm; 30 x 2.00 mm; 40 x 4.00 mm; 50 x 3.00 mm

A099

A099F1

A099M1



A099DRILLBOY

Set

Set	A	B	C
DRILLBOY	A002	43	3 x (3.0 mm, 3.3 mm, 3.5 mm, 4.0 mm) 2 x (4.2 mm, 4.5 mm, 5.0 mm, 5.5 mm, 6.0 mm, 6.5 mm, 6.8 mm, 7.0 mm, 7.5 mm, 8.0 mm) + 8.5 mm, 9.0 mm, 9.5 mm, 10.0 mm, 10.2 mm, 10.5 mm, 11.0 mm, 11.5 mm, 12.0 mm, 12.5 mm, 13.0 mm

A099

A099DRILLBOY

A199

- Espositore con punte
- Spiralbohrer Dispenser
- Toonbankdispencer
- Présentoir

A=Tipi in serie, B=No. punte in Set, C=diametri in Set

A=Typen in Satz, B=Anzahl, C=Durchmesser im Satz

A=Type, B=Aantal, C=Diameters

A=Types de coffrets, B=Nombre dans le coffret, C=Diamètres dans le coffret

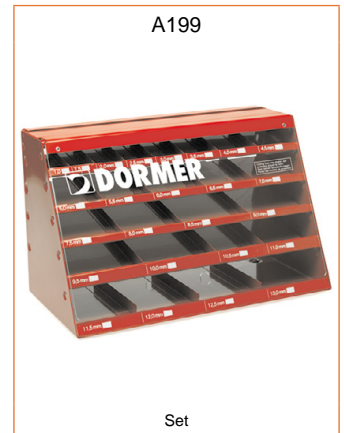

Set	A	B	C	A199
F1	A100	380	5 x (13/32, 7/16, 15/32, 1/2) inch; 10 x (5/64, 7/64, 9/64, 11/64, 13/64, 15/64, 17/64, 9/32, 19/64, 5/16, 21/64, 11/32, 23/64, 3/8) inch; 20 x (1/16, 7/32, 1/4) inch; 30 x 3/32 inch; 40 x (5/32, 3/16) inch; 50 x 1/8 inch	A199F1
M1	A100	340	5 x (10.50, 11.00, 11.50, 12.00, 12.50, 13.00) mm; 10 x (1.50, 2.50, 3.50, 4.50, 5.50, 6.50, 7.00, 7.50, 8.00, 8.50, 9.00, 9.50, 10.00) mm; 20 x (1.00, 5.00, 6.00) mm; 30 x 2.00 mm; 40 x 4.00 mm; 50 x 3.00 mm	A199M1

A080

- Espositore con punte
- Spiralbohrer Dispenser
- Toonbankdispencer
- Présentoir

- Distributore vuoto
- Leer-Dispenser
- Lege dispenser
- Présentoir vide



Nr.	d Ø mm	
M1EMPTY	(1.00, 1.50, 2.00, 2.50, 3.00, 3.50, 4.00, 4.50, 5.00, 5.50, 6.00, 6.50, 7.00, 7.50, 8.00, 8.50, 9.00, 9.50, 10.00, 10.50, 11.00, 11.50, 12.00) mm	A080M1EMPTY
F1EMPTY	(1/16, 5/64, 3/32, 7/64, 1/8, 9/64, 5/32, 11/64, 3/16, 13/64, 7/32, 15/64, 1/4, 17/64, 9/32, 19/64, 5/16, 21/64, 11/32, 3/8, 13/32, 7/16, 1/2) inch	A080F1EMPTY

A190

- Punta serie corta, set
- Spiralbohrer, Satz
- Spiraalboor in set
- Coffret de forets courts

A=Tipi in serie, B=No. punte in Set, C=diametri in Set

A=Typen in Satz, B=Anzahl, C=Durchmesser im Satz

A=Type, B=Aantal, C=Diameters

A=Types de coffrets, B=Nombre dans le coffret, C=Diamètres dans le coffret



Set	A	B	C	A190
3	A100	21	1/16 inch - 3/8 inch x 1/64 inch	A1903
12	A100	60	No.1 - No.60	A19012
18	A100	29	1/16 inch - 1/2 inch x 1/64 inch	A19018
20	A100	15	1/16 inch - 1/2 inch x 1/32 inch	A19020
201	A100	19	1.0 mm - 10.0 mm x 0.5 mm	A190201
202	A100	51	1.0 mm - 6.0 mm x 0.1 mm	A190202
203	A100	41	6.0 mm - 10.0 mm x 0.1 mm	A190203
204	A100	25	1.0 mm - 13.0 mm x 0.5 mm	A190204
206	A100	29	1.0 mm - 13.0 mm x 0.5 mm + 3.3 mm, 4.2 mm, 6.8 mm, 10.2 mm	A190206
209	A100	91	1.0 mm - 10.0 mm x 0.1 mm	A190209 ⁸⁾

⁸⁾ A190209 viene venduto in 2 scatole: scatola 1 (1,0-5,9 x 0,1 mm) + scatola2 (6,0-10,0 x 0,1 mm) / A190209 wird in 2 Boxen verkauft: Box 1 (1,0-5,9 x 0,1 mm) + Box 2 (6,0-10,0 x 0,1 mm) / A190209 wordt geleverd in 2 boxen: box 1 (1,0-5,9 x 0,1 mm) + box 2 (6,0-10,0 x 0,1 mm) / La réf. A190209 est vendue en 2 boîtes : boîte 1 (1,0-5,9 x 0,1 mm) + boîte 2 (6,0-10,0 x 0,1 mm)

A191

- Punta serie corta,set Senza trattamento sotto 1,0 mm , 3/64",N60 A=Tipi in serie, B=No. punte in Set, C=diametri in Set
- Spiralbohrer, Satz Blank bis 1 mm Ø, A=Typen in Satz, B=Bohreranzahl C=Durchmesser im Satz
- Spiraalboor in set Blank beneden 1,0mm, 3/64", N60. A=Type, B=Aantal, C=Diameters
- Coffret de forets courts Brillant au dessous de 1,0 mm, 6/64, N60. A=Types de coffrets, B=Nombre de forets dans le coffret, C=Diamètres dans le coffret



Set	A	B	C	A191
31M	A100	20	0.3 mm - 1.0 mm x 0.05 mm + 0.38 mm, 0.52 mm, 0.58 mm, 0.78 mm, 0.82 mm	A19131M
61-80	A100	20	No.61 - No. 80	A19161-80
413	A100	13	1.5 mm - 6.5 mm x 0.5 mm + 3.3 mm, 4.2 mm	A191413
419	A100	19	1.0 mm - 10.0 mm x 0.5 mm	A191419

A188

- Punta serie corta,set
- Spiralbohrer, Satz
- Spiraalboor in set
- Coffret de forets courts

A=Tipi in serie, B=No. punte in Set, C=diametri in Set

A=Typen in Satz, B=Anzahl, C=Durchmesser im Satz

A=Type, B=Aantal, C=Diameters

A=Types de coffrets, B=Nombre dans le coffret, C=Diamètres dans le coffret



A188

Set

Nr.	A	B	C	A188
201	A108	19	1.0 mm - 10.0 mm x 0.5 mm	A188201
204	A108	25	1.0 mm - 13.0 mm x 0.5 mm	A188204

A295

- Punta serie corta, set Affilatura a 4 facce fino a 1,4 mm, A=Tipi in serie, B=No. punte in Set, C=diametri in Set
- Spiralbohrer, Satz 4Flächenanschliff bis 1,4 mm Ø, A=Typen in Satz, B=Anzahl, C=Durchmesser im Satz
- Spiraalboor in set Viervlaks punt vanaf 1,4mm. A=Typen in set, B=No. in sets, C=diameters in sets
- Coffret de forets courts Pointe à 4 facettes jusqu'au Ø 1,4 mm. A=Types de coffrets, B=Nombre de forets dans le coffret, C=Diamètres dans le coffret



Set	A	B	C	A295
219	A777	19	1.0 mm - 10.0 mm x 0.5 mm	A295219
225	A777	25	1.0 mm - 13.0 mm x 0.5 mm	A295225

A296

- Punte da centro, set
- Zentrierbohrer Satz
- Centerboor set
- Jeu de foret à centrer

A296200 - 118° DIN 333A, A296225 - 120° BS328. A=Tipi in serie, B=No. punte in Set, C=diametri in Set

A296200 - 118° anschliiff DIN333A, A296225 - 120° anschliiff BS328. A=Typen in Satz, B=Anzahl, C=Durchmesser im Satz

A296200 - 118° punt DIN333A, A296225 - 120° punt BS328. A=Type, B=Aantal, C=Diameters

A296200 - pointe 118° DIN333A, A296225 - pointe 120° BS328. A=Types de coffrets, B=Nombre dans le coffret, C=Diamètres dans le coffret



Nr.	A	B	C	A296
200	A200	5	1.00 mm, 2.00 mm, 2.50 mm, 3.15 mm, 4.00 mm	A296200
225	A225	5	BS1, BS2, BS3, BS4, BS5	A296225



143 - 200



B100	158	B411	156	G106	189	G171	196
B101	176	B441	155	G107	192	G236	199
B121	178	B442	157	G125	198	G314	197
B122	166	B481	153	G129	187	G335	184
B157	173	B901	162	G132	194	G338	195
B161	174	B903	164	G135	184	G400	183
B170	170	B952	165	G136	189	G506	189
B180	168	B953	167	G137	185	G560	189
B301	163	B954	179	G138	195	G570	191
B334	160	B955	180	G142	191	G600	193
B335	161	B956	181	G149	188		
B400	152	B957	182	G154	186		

Materiale	Material	Materiaal	Matière
Trattamento superficiale	Oberfläche	Oppervlaktebehandeling	Revêtement
Normativa	Standard	Norm	Standard
Senso di rotazione	Schneidrichtung	Draairichting	Direction
Codolo	Schaft	Schacht	Queue
Tipo di elica	Nutenausführung	Spaangroef vorm	Type de goujures
Tolleranza	Toleranz	Tolerantie	Tolérance
Gradi di conicità al tagliente	Kegelwinkel	Coniciteit	Conicité
■ Raccomandato	Sehr gut für die Anwendung	Uitstekend voor deze toepassing	Excellent pour les applications
● Accettabile	Gut für die Anwendung	Acceptabel voor deze toepassing	Acceptable pour les applications
Esempio 10 = Velocità periferica in m/min +/- 10%	Beispiel 10 = Schnittgeschwindigkeit (m/min) +/- 10 %	Voorbeeld 10 = snijnsnelheid in m/min +/-10%	Exemple 10 = Vitesse périphérique en mètres/ minute +/- 10%
Codice prodotto	Produktbezeichnung	Productcode	Codes
Gamma diametri	Durchmesserbereich	Diameterreeks	Gamme

AMG	Italiano	Deutsch	Nederlands	Français
1.1	Acciaio dolce magnetico	Magnetweicheisen	Automatenstaal, zachtstaal	Acier doux magnétique
1.2	Acciaio da costruzione e da cementazione	Baustahl, Einsatzstahl	Constructiestaal, inzetstaal	Acier de construction, Acier de cémentation
1.3	Acciaio al carbonio	Kohlenstoffstahl	Koolstofstaal	Acier au carbone ordinaire
1.4	Acciaio legato	Legierter Stahl	Gelegeerd staal	Acier allié
1.5	Acciaio legato / Acciaio bonificato e temprato	Legierter und vergüteter Stahl	Gelegeerd en veredeld staal	Acier allié/ Acier trempé et revenu
1.6	Acciaio legato / Acciaio bonificato e temprato	Legierter und vergüteter Stahl	Hooggelegeerd veredeld staal	Acier allié/ Acier trempé et revenu
1.7	Acciaio legato/temprato	Legierter gehärteter Stahl	Gelegeerd en gehard staal	Acier allié trempé
1.8	Acciaio legato/temprato	Legierter gehärteter Stahl	Gelegeerd en gehard staal	Acier allié trempé
2.1	Acciaio inossidabile/automatico	Rostfreier Stahl, geschwefelt	Roestvast automatenstaal	Acier inoxydable de décolletage
2.2	Austenitico	Austenitisch	Austenitisch	Austénitique
2.3	Ferritico+Austenitico, Martensitico	Ferritisch+Austenitisch, Martensitisch	Ferritisch+Austenitisch, Martensitisch	Ferritique + Austénitique, Martensitique
2.4	Acciai inossidabili con indurimento da precipitazione	Vergüteter rostfreier Stahl	Precipitatiehardend roestvast staal	Acier inoxydable Trempé
3.1	Ghisa con grafite lamellare	Grauguss	Gietijzer Lamellair	Graphite lamellaire
3.2	Ghisa con grafite lamellare	Vergüteter Grauguss	Gietijzer Lamellair	Graphite lamellaire
3.3	Ghisa malleabile con grafite sferoidale	Kugelgraphitguss, Temperguss	Nodulair gietijzer / Smeedbaar gietijzer	Graphite nodulaire/ Fonte malléable
3.4	Ghisa malleabile con grafite sferoidale	Kugelgraphitguss, Temperguss	Nodulair gietijzer / Smeedbaar gietijzer	Graphite nodulaire/ Fonte malléable
4.1	Titanio non legato	Reintitan	Titaan, ongelegeerd	Titane, non-allié
4.2	Leghe di titanio	Titan-Legierungen	Titaan, gelegeerd	Titane, allié
4.3	Leghe di titanio	Titan-Legierungen	Titaan, gelegeerd	Titane, allié
5.1	Nichel non legato	Reinnickel	Nikkel, ongelegeerd	Nickel, non-allié
5.2	Leghe di nichel	Nickel-Legierungen	Nikkel, gelegeerd	Nickel, allié
5.3	Leghe di nichel	Nickel-Legierungen	Nikkel, gelegeerd	Nickel, allié
6.1	6.1 Rame	Kupfer	Koper	Cuivre
6.2	β-Ottone, Bronzo	Kurzspanendes Messing, Bronze	β-Messing, brons	β-Laiton, Bronze
6.3	α-Ottone	Langspanendes Messing	α-Messing	α-Laiton
6.4	Bronzo ad alta resistenza	Cu-Al-Fe-Legierung, (Ampco)	Extra-sterk brons	Bronze, haute résistance
7.1	Al, Mg, non legato	Al, Mg, unlegiert	Al, Mg, ongelegeerd	Al, Mg, non-allié
7.2	Leghe di Al, Si < 0.5%	Al legiert, Si<0.5 %	Al gelegeerd, Si < 0.5%	Al allié, Si < 0.5%
7.3	Leghe di Al, Si > 0.5% < 10%	Al legiert, Si>0.5 %<10 %	Al gelegeerd, Si > 0.5% < 10%	Al allié, Si > 0.5% < 10%
7.4	Leghe di Al, Si > 10% Rinforzate Whisker Leghe di Al, Leghe di Mg	Al legiert, Si>10 % Whisker verstärkte Al-Legierung, Mg-Legierung	Al gelegeerd, Si>10% whisker versterkt Al-legierungen, Mg-legierungen	Al allié, Si>10% Alliages d'Al ou Mg, céramique renforcée
8.1	Materiali termoplastici	Thermoplaste	Thermoplasten	Thermoplastiques
8.2	Materiali plastici termoindurenti	Duroplaste	Duraplasten	Plastiques thermodurcissables
8.3	Materiali plastici rinforzati	Faserverstärkte Kunststoffe	Versterkte kunststofmaterialen	Plastiques renforcés
9.1	Cermets (materiali metallo-ceramici)	Cermets (Metallkeramik)	Cermets (metal-ceramics)	Cermets (céramiques métalliques)
10.1	Grafite standard	Graphit	Standaard Grafiet	Graphite standard

	HM	HM	HM	HM	HM	HSS	HSS	HSS	HSS-E	HSS	HSS	HSS	HSS	HSS-E	HSS-E	HSS-E	HSS-E	
	DIN 8093	DIN 8093	DIN 8050	DIN 8094	DIN 8051	DIN 206	DORMER	DORMER	BS 328	BS 328	DIN 9	DIN 9	ANSI	DIN 2179	DIN 212	DIN 212	DIN 212	
		DIN 6535HA 													DIN 6535HA 			
	B	B	A	B	A	B			B	A	A	B			B	B	E	
	H7	0.95-5.5 0,+0.004 05.51-12 0,+0.005	H7	H7	H7	H7			H7						H7	0.95-5.5 0,+0.004 05.51-12 0,+0.005	H7	
									1:48	1:50	1:50			1:50				
	B400	B481	B441	B411	B442	B100	B334	B335	B901	B301	B903	B952	B122	B953	B180	B170	B157	
	1.00 - 20.00	0.98 - 12.05	10.00 - 20.00	5.00 - 30.00	10.00 - 20.00	1.50 - 50.00	N000 - N16	N000BLADES - N16NUT	1.50 - 1/2	1/16 - 1/2	1.50 - 20.00	1.20 - 50.00	3/8 - 1.1/16	1.00 - 12.00	1.50 - 20.0	0.98 - 12.00	2.00 - 20.00	
AMG	152	153	155	156	157	158	160	161	162	163	164	165	166	167	168	170	173	ISO
1.1	18B	18B	18B	18B	18B	18C	18C		18C	18C	18C	18C	18C	25C	25C	25C	25C	P 1
1.2	18B	18B	18B	18B	18B	14C	14C		14C	14C	14C	14C	14C	20C	20C	20C	20C	P 1
1.3	14B	14B	14B	14B	14B	11C	11C		11C	11C	11C	11C	11C	16C	16C	16C	16C	P 2
1.4	14B	14B	14B	14B	14B	10B	10B		10B	10B	10B	10B	10B	15B	15B	15B	15B	P 3
1.5	10C	10C	10C	10C	10C	5B	5B		5B	5B	5B	5B	5B	9B	9B	9B	9B	P 4
1.6	10C	10C	10C	10C	10C	4A	4A		4A	4A	4A	4A	4A	5A	5A	5A	5A	H 1
1.7																		H 3
1.8																		H 4
2.1						8F	8F		8C	8C	8C	8C	8C	11C	11C	11C	11C	M 1
2.2									5B	5B	5B	5B	5B	6B	6B	6B	6B	M 3
2.3									6B	6B	6B	6B	6B	8B	8B	8B	8B	M 2
2.4														6B				S 2
3.1	17D	17D	17D	17D	17D	14E	14E		14E	14E	14E	14E	14E	16E	16E			K 1
3.2	17D	17D	17D	17D	17D	11D	11D		11D	11D	11D	11D	11D	15D	15D			K 2
3.3	17D	17D	17D	17D	17D	10C	10C		10C	10C	10C	10C	10C	13C	13C			K 3
3.4	14D	14D	14D	14D	14D	9C	9C		9C	9C	9C	9C	9C	11C	11C			K 4
4.1	14C	14C	14C	14C	14C	11C	11C		11C	11C	11C	11C	11C	15C	15C	15C	15C	S 1
4.2	14C	14C	14C	14C	14C	5B	5B		5B	5B	5B	5B	5B	9B	9B	9B	9B	S 2
4.3	10B	10B	10B	10B	10B	4B	4B		4B	4B	4B	4B	4B	5B	5B	5B	5B	S 3
5.1	10C	10C	10C	10C	10C	5D	5D		5D	5D	5D	5D	5D	8D	8D	8D	8D	S 1
5.2	10B	10B	10B	10B	10B	3C	3C		3C					5C	5C	5C	5C	S 2
5.3	10B	10B	10B	10B	10B	2C	2C		2C					3C	3C	3C	3C	S 3
6.1	38E	38E	38E	38E	38E	18D	18D		18D	18D	18D	18D	18D	25D	25D	25D	25D	N 3
6.2	38E	38E	38E	38E	38E	20E	20E		20E	20E	20E	20E	20E	28E	28E	28E	28E	N 4
6.3	38E	38E	38E	38E	38E	18D	18D		18D	18D	18D	18D	18D	25D	25D			N 3
6.4	38D	38D	38D	38D	38D	11D	11D		11D	11D	11D	11D	11D	14D	14D			N 4
7.1	60D	60D	60D	60D	60D	23F	23F		23F	23F	23F	23F	23F	28F			28F	N 1
7.2	60D	60D	60D	60D	60D	18F	18F		18F	18F	18F	18F	18F	25F			25F	N 1
7.3	25D	25D	25D	25D	25D				15E	15E	15E	15E	15E	20E			20E	N 1
7.4	25D	25D	25D	25D	25D				14D	14D	14D	14D	14D	16D			16D	N 2
8.1	25C	25C	25C	25C	25C									30B			30B	O
8.2	13C	13C	13C	13C	13C	21B	21B		21B	21B	21B	21B	21B					O
8.3																		O
9.1														3A			3A	H
10.1																		O

	HSS-E	HSS-E	HSS	HSS-E	HSS-E	HSS-E		
	DIN 208	BS 328	DIN 311	DIN 2180	DIN 219	DIN 217		
	B	B			B			
	H7	H7	k11		H7			
				1:50				
	B161	B101	B121	B954	B955	B956	B957	
	3.00 - 50.00	3.00 - 2"	10.00 - 30.00	5.00 - 30.00	25.00 - 80.00	13.00 - 40.00	N3DRIVER - N9WASHER	
AMG	174	176	178	179	180	181	182	ISO
1.1	■25C	■18C	■18C	●25C	■18C			P 1
1.2	■20C	■14C	■14C	●20C	■14C			P 1
1.3	■16C	■11C	■11C	●16C	■11C			P 2
1.4	■15B	■10B	■10B	●15B	■10B			P 3
1.5	●9B	●5B	●5B	●9B	●5B			P 4
1.6	●5A	●4A	●4A	●5A	●4A			H 1
1.7								H 3
1.8								H 4
2.1	■11C	■8C		■11C	■8C			M 1
2.2	●6B			■6B	●5B			M 3
2.3	●8B			■8B	●6B			M 2
2.4								S 2
3.1	●16E	■14E	■14E		●14E			K 1
3.2	●15D	●11D	●11D					K 2
3.3	●13C	●10C	●10C					K 3
3.4	●11C	●9C	●9C					K 4
4.1	■15C	■11C	■11C	■15C	■11C			S 1
4.2	●9B	●5B		■9B	●5B			S 2
4.3	●5B	●4B		■5B	●4B			S 3
5.1	■8D	●5D		■8D	■5D			S 1
5.2	●5C	●3C		■5C	●3C			S 2
5.3	●3C	●2C		■3C	●2C			S 3
6.1	●25D	●18D		■25D	●18D			N 3
6.2	●28E	■20E		●28E	●20E			N 4
6.3	●25D	●18D						N 3
6.4	●14D	●11D						N 4
7.1		●23F		■28F	●23F			N 1
7.2		●18F		■25F	●18F			N 1
7.3				■20E	●15E			N 1
7.4				■16D	●14D			N 2
8.1				■30B				O
8.2		●21B	●21B		●21B			O
8.3								O
9.1				●3A				H
10.1								O

Materiale	Material	Materiaal	Matière
Trattamento superficiale	Oberfläche	Oppervlaktebehandeling	Revêtement
Normativa	Standard	Norm	Standard
Senso di rotazione	Schneidrichtung	Draairichting	Direction
Applicazione	Anwendung	Toepassing	Utilisation
Codolo	Schaft	Schacht	Queue
Angolo di svasatura	Senkwinkel	Verzinkhoek	Angle
■ Raccomandato	Sehr gut für die Anwendung	Uitstekend voor deze toepassing	Excellent pour les applications
● Accettabile	Gut für die Anwendung	Acceptabel voor deze toepassing	Acceptable pour les applications
Esempio 10 = Velocità periferica in m/min +/- 10%	Beispiel 10 = Schnittgeschwindigkeit (m/min) +/- 10 %	Voorbeeld 10 = snijnsnelheid in m/min +/-10%	Exemple 10 = Vitesse périphérique en mètres/ minute +/- 10%
Codice prodotto	Produktbezeichnung	Productcode	Codes
Gamma diametri	Durchmesserbereich	Diameterreeks	Gamme

AMG	Italiano	Deutsch	Nederlands	Français
1.1	Acciaio dolce magnetico	Magnetweicheisen	Automatenstaal, zachtstaal	Acier doux magnétique
1.2	Acciaio da costruzione e da cementazione	Baustahl, Einsatzstahl	Constructiestaal, inzetstaal	Acier de construction, Acier de cémentation
1.3	Acciaio al carbonio	Kohlenstoffstahl	Koolstofstaal	Acier au carbone ordinaire
1.4	Acciaio legato	Legierter Stahl	Gelegeerd staal	Acier allié
1.5	Acciaio legato / Acciaio bonificato e temprato	Legierter und vergüteter Stahl	Gelegeerd en veredeld staal	Acier allié/ Acier trempé et revenu
1.6	Acciaio legato / Acciaio bonificato e temprato	Legierter und vergüteter Stahl	Hooggelegeerd veredeld staal	Acier allié/ Acier trempé et revenu
1.7	Acciaio legato/temprato	Legierter gehärteter Stahl	Gelegeerd en gehard staal	Acier allié trempé
1.8	Acciaio legato/temprato	Legierter gehärteter Stahl	Gelegeerd en gehard staal	Acier allié trempé
2.1	Acciaio inossidabile/automatico	Rostfreier Stahl, geschwefelt	Roestvast automatenstaal	Acier inoxydable de décolletage
2.2	Austenitico	Austenitisch	Austenitisch	Austénitique
2.3	Ferritico+Austenitico, Martensitico	Ferritisch+Austenitisch, Martensitisch	Ferritisch+Austenitisch, Martensitisch	Ferritique + Austénitique, Martensitique
2.4	Acciai inossidabili con indurimento da precipitazione	Vergüteter rostfreier Stahl	Precipitatiehardend roestvast staal	Acier inoxydable Trempé
3.1	Ghisa con grafite lamellare	Grauguss	Gietijzer Lamellair	Graphite lamellaire
3.2	Ghisa con grafite lamellare	Vergüteter Grauguss	Gietijzer Lamellair	Graphite lamellaire
3.3	Ghisa malleabile con grafite sferoidale	Kugelgraphitguss, Temperguss	Nodulair gietijzer / Smeedbaar gietijzer	Graphite nodulaire/ Fonte malléable
3.4	Ghisa malleabile con grafite sferoidale	Kugelgraphitguss, Temperguss	Nodulair gietijzer / Smeedbaar gietijzer	Graphite nodulaire/ Fonte malléable
4.1	Titanio non legato	Reintitan	Titaan, ongelegeerd	Titane, non-allié
4.2	Leghe di titanio	Titan-Legierungen	Titaan, gelegeerd	Titane, allié
4.3	Leghe di titanio	Titan-Legierungen	Titaan, gelegeerd	Titane, allié
5.1	Nichel non legato	Reinnickel	Nikkel, ongelegeerd	Nickel, non-allié
5.2	Leghe di nichel	Nickel-Legierungen	Nikkel, gelegeerd	Nickel, allié
5.3	Leghe di nichel	Nickel-Legierungen	Nikkel, gelegeerd	Nickel, allié
6.1	6.1 Rame	Kupfer	Koper	Cuivre
6.2	β-Ottone, Bronzo	Kurzspanendes Messing, Bronze	β-Messing, brons	β-Laiton, Bronze
6.3	α-Ottone	Langspanendes Messing	α-Messing	α-Laiton
6.4	Bronzo ad alta resistenza	Cu-Al-Fe-Legierung, (Ampco)	Extra-sterk brons	Bronze, haute résistance
7.1	Al, Mg, non legato	Al, Mg, unlegiert	Al, Mg, ongelegeerd	Al, Mg, non-allié
7.2	Leghe di Al, Si < 0.5%	Al legiert, Si<0.5 %	Al gelegeerd, Si < 0.5%	Al allié, Si < 0.5%
7.3	Leghe di Al, Si > 0.5% < 10%	Al legiert, Si>0.5 %<10 %	Al gelegeerd, Si > 0.5% < 10%	Al allié, Si > 0.5% < 10%
7.4	Leghe di Al, Si > 10% Rinforzate Whisker Leghe di Al, Leghe di Mg	Al legiert, Si>10 % Whisker verstärkte Al-Legierung, Mg-Legierung	Al gelegeerd, Si>10% whisker versterkt Al-Legierungen, Mg-Legierungen	Al allié, Si>10% Alliages d'Al ou Mg, céramique renforcée
8.1	Materiali termoplastici	Thermoplaste	Thermoplasten	Thermoplastiques
8.2	Materiali plastici termoidurenti	Duroplaste	Duraplasten	Plastiques thermodurcissables
8.3	Materiali plastici rinforzati	Faserverstärkte Kunststoffe	Versterkte kunststofmaterialen	Plastiques renforcés
9.1	Cermets (materiali metallo-ceramici)	Cermets (Metallkeramik)	Cermets (metal-ceramics)	Cermets (céramiques métalliques)
10.1	Grafite standard	Graphit	Standaard Grafiet	Graphite standard

	HM	HSS	HSS	HSS	HSS	HSS	HSS-E	HSS	HSS	HSS	HSS	HSS	HSS-E	HSS-E	
	DIN 335C	DIN 334C	DIN 334C	DIN 334D	DIN 335C	DORMER	DORMER	DIN 335C	DIN 335C	DIN 335C	DIN 335C	DIN 335C	DIN 335C	DORMER	
	G400	G135	G335	G137	G154	G129	G149	G136	G560	G106	G506	G142	G570	G107	
	6.30 - 31.00	6.30 - 25.00	6.30 - 25.00	16.00 - 80.00	6.30 - 25.00	6.00 - 31.50	5.00 - 50.00	4.30 - 31.00	6.30 - 31.00	6.30 - 50.00	6.30 - 50.00	4.80 - 31.00	6.30 - 31.00	6.30 - 20.50	
AMG	183	184	184	185	186	187	188	189	189	189	189	191	191	192	ISO
1.1	■30F	■30F	■50E	■30F	■30F	■30D	■30D	■30F	■50E	■30F	■50E	■30F	●45E	■30F	P 1
1.2	■25E	■25E	■40E	■25E	■25E	■25D	■25D	■25E	■40E	■25E	■40E	■25E	●36E	■25E	P 1
1.3	■20D	■20D	■30D	■20D	■20D	■20C	■20C	■20D	■30D	■20D	■30D	■20D	●20D	■20D	P 2
1.4	■15D	■15D	●20D	■15D	■15D	■15B	■15B	■15D	■20D	■15D	●20D	●15D	■22D	■15D	P 3
1.5	■10B	■10B	●15B	■10B	■10B	●10A	●10A	●10B	■15B	■10B	●15B	■17B	■10B	■10B	P 4
1.6	●6A	●6A	●10B	●6A	●6A	●6A	●6A	●6A	●10B	●6A	●10B	●12B	●6A	●6A	H 1
1.7															H 3
1.8															H 4
2.1	●8C	●8C		●8C	●8C	●8B	●8B	●8C	■8C	●8C		■8C	■17C	●8C	M 1
2.2	●6B	●6B		●6B	●6B	●6A	●6A	●6B	●6B	●6B		■6B	■12B	●6B	M 3
2.3	●4A	●4A		●4A	●4A			●4A	●4A	●4A		■4A	■15A	●4A	M 2
2.4													●10A		S 2
3.1	●25F	●25F	■45F	●25F	●25F	●25D	●25D	●25F	■45F	●25F	■45F		●40C	●25F	K 1
3.2	●15D	●15D	■35D	●15D	●15D	●15C	●15C	●15D	■35D	●15D	■35D		●32C	●15D	K 2
3.3	●12C	●12C	■30C	●12C	●12C	●12A	●12A	●12C	■30C	●12C	■30C		●27C	●12C	K 3
3.4	●8C	●8C	■30C	●8C	●8C	●8A	●8A	●8C	■30C	●8C	■30C		●24C	●8C	K 4
4.1	■12C	■12C	●20C	■12C	■12C	■12B	■12B	■12C	●20C	■12C	●20C	■12C		■12C	S 1
4.2	■10A	■10A	●15A	■10A	■10A	■10A	■10A	■10A	●15A	■10A	●15A	●10A		■10A	S 2
4.3	■8A	■8A	●10A	■8A	■8A	●8A	●8A	●8A	●10A	■8A	●10A			■8A	S 3
5.1	■12C	■12C	●20C	■12C	■12C	■12B	■12B	■12C	●20C	■12C	●20C	■12C		■12C	S 1
5.2	■6B	■6B	●10B	■6B	■6B	■6A	■6A	■6B	■10B	■6B	●10B	●6B	●6A	■6B	S 2
5.3	■4A	■4A	●6A	■4A	■4A	●4A	●4A	●4A	■6A	■4A	●6A	●4A	●4A	■4A	S 3
6.1	■25D	■25D	●40D	■25D	■25D	■25B	■25B	■25D	●40D	■25D	■25D	■25D	■25D	■25D	N 3
6.2	■20F	■20F	●30F	■20F	■20F	■20C	■20C	■20F	●30F	■20F	●30F	■20F	●30F	■20F	N 4
6.3	■25F	■25F	●40F	■25F	■25F	■25C	■25C	■25F	●40F	■25F	●40F	●25F	●40F	■25F	N 3
6.4	●10D	●10D	●15D	●10D	●10D	●10B	●10B	●10D	●15D	●10D	●15D	●15D	●15D	●10D	N 4
7.1	■30G	■30G	■50G	■30G	■30G	■30D	■30D	■30G	■50G	■30G	■50G	■30G	●45G	■30G	N 1
7.2	■25F	■25F	■40F	■25F	■25F	■25C	■25C	■25F	●40F	■25F	■40F	■25F	●36F	●25F	N 1
7.3	●20F	●20F	■30F	●20F	●20F	●20C	●20C	●20F	■30F	●20F	■30F	●20F	●27F	●20F	N 1
7.4	●10F	●10F	■15F	●10F	●10F	●10C	●10C	●10F	■15F	●10F	■15F	●10F	●13F	●10F	N 2
8.1	●30G	●30G	●50G	●30G	●30G	■30D	■30D	■30G	●50G	●30G	●50G	■30G		●30G	O
8.2	●20G	●20G	●30G	●20G	●20G	●20D	●20D	●20G	●30G	●20G	●30G	■20G		●20G	O
8.3															O
9.1															H
10.1															O

HSS	HSS	HSS	HSS	HSS	HSS	HSS
DORMER	DIN 335A	DIN 335D	DIN 335D	DIN 335C	DORMER	DIN 373
90°	90°	90°	90°	100°	20°	180°
G600	G132	G138	G338	G171	G314	G125
6.30 - 25.00	8.00 - 20.00	25.00 - 80.00	25.00 - 63.00	6.30 - 25.00	4.00 - 9.00	6.50 - 20.00
						G236
						Set

AMG	193	194	195	195	196	197	198	199	ISO
1.1	■22F		■30F	■50F	■50E	■30D	■30E		P 1
1.2	■17E		■25E	■40E	■40E	■25D	■25E		P 1
1.3	■15D	●20E	■20D	■30D	■30D	■20C	■20D		P 2
1.4	■12D	●15D	■15D	■20D	●20D	■15B	●15D		P 3
1.5	■8B	■10D	■10B	■15B	●15B	●10A	●10C		P 4
1.6	●6A	■6B	●6A	●10A	●10B	●6A	●6C		H 1
1.7									H 3
1.8									H 4
2.1	●8C		●8C			●8B	■8D		M 1
2.2	●6B		●6B			●6A	●6C		M 3
2.3	●4A	●4B	●4A			●4A			M 2
2.4									S 2
3.1	●25F		●25F	■45F	■45F	●25D	■25E		K 1
3.2	●15D		●15D	■35D	■35D	●15C	■15E		K 2
3.3	●12C		●12C	■30C	■30C	●12A	●12D		K 3
3.4		■8D	●8C	■30C	■30C	●8A	●8C		K 4
4.1			■12C	●20C	●20C	■12B	●12E		S 1
4.2		■8A	■10A	●15A	●15A	■10A	●10E		S 2
4.3		■8A	■8A	●10A	●10A	■8A	●8E		S 3
5.1			■12C	●20C	●20C	■12B	●12E		S 1
5.2		■6C	■6B	●10B	●10B	■6A	●6C		S 2
5.3		■4B	■4A	●6A	●6A	■4A	●4E		S 3
6.1	●25D		■25D	●40D	●40D	■25B	●25C		N 3
6.2	●20F		■20F	●30F	●30F	■20C	●20C		N 4
6.3	●25F		■25F	●40F	●40F	■25C	●25C		N 3
6.4	●10D	■10F	●10D	●15D	●15D	●10B			N 4
7.1	■30G		●30G	■50G	■50G	■30D	■30G		N 1
7.2	●25F		●25F	■40F	■40F	■25C	■25G		N 1
7.3	●20F		●20F	■30F	■30F	●20C	●20G		N 1
7.4	●10F		●10F	■15F	■15F	●10C	●10E		N 2
8.1			●30G	●50G	●50G	■30D	■30C		O
8.2			●20G	●30G	●30G	■20D	●20C		O
8.3		●5G							O
9.1									H
10.1									O

	Ø mm												
	1,5	2	3	5	8	10	12	16	20	25	30	40	50
A	0,045	0,055	0,078	0,100	0,150	0,170	0,185	0,220	0,250	0,280	0,320	0,390	0,440
B	0,055	0,072	0,110	0,150	0,180	0,210	0,240	0,280	0,310	0,360	0,400	0,500	0,550
C	0,065	0,085	0,135	0,185	0,220	0,260	0,285	0,335	0,390	0,440	0,480	0,600	0,680
D	0,080	0,110	0,160	0,200	0,270	0,320	0,360	0,410	0,470	0,540	0,600	0,730	0,850
E	0,100	0,140	0,180	0,250	0,350	0,390	0,430	0,500	0,530	0,640	0,750	0,910	1,100
F	0,140	0,180	0,260	0,350	0,440	0,500	0,550	0,630	0,700	0,800	0,930	1,200	1,500

mm/REV ± 15 %

	Ø mm										
	6	8	10	16	20	25	32	40	60	80	
A	0.03	0.04	0.05	0.06	0.08	0.09	0.10	0.12	0.14	0.16	
B	0.04	0.05	0.06	0.08	0.10	0.12	0.14	0.16	0.18	0.20	
C	0.05	0.06	0.08	0.10	0.12	0.14	0.16	0.18	0.20	0.22	
D	0.06	0.08	0.10	0.12	0.15	0.18	0.20	0.22	0.25	0.28	
E	0.08	0.10	0.12	0.15	0.18	0.20	0.25	0.27	0.30	0.32	
F	0.09	0.11	0.13	0.16	0.19	0.21	0.26	0.29	0.33	0.36	
G	0.10	0.12	0.15	0.18	0.20	0.22	0.28	0.32	0.36	0.40	
H	0.12	0.15	0.18	0.20	0.22	0.25	0.30	0.35	0.40	0.45	

mm/REV

• Valori di sovrametallo per prefiori di alesatura • Allgemeine Richtlinien für Reibaufmass beim Vorbohren • Algemene richtlijn voor materiaal afname bij voorboren • Préconisations de surépaisseur de perçage avant alésage

	Ø (mm)					
	3 - 5mm	5.1 - 10mm	10.1 - 20mm	20.1 - 30mm	> 30mm	
1.1	0.1-0.2	0.2	0.2-0.3	0.3-0.4	0.4-0.5	P 1
1.2	0.1-0.2	0.2	0.2-0.3	0.3-0.4	0.4-0.5	P 1
1.3	0.1-0.2	0.2	0.2-0.3	0.3-0.4	0.4-0.5	P 2
1.4	0.1-0.2	0.2	0.2	0.3	0.3-0.4	P 3
1.5	0.1-0.2	0.2	0.2	0.3	0.3-0.4	P 4
1.6	0.1-0.2	0.2	0.2	0.3	0.3-0.4	H 1
1.7	0.1-0.2	0.2	0.2	0.3	0.3-0.4	H 3
1.8	0.1-0.2	0.2	0.2	0.3	0.3-0.4	H 4
2.1	0.1-0.2	0.2	0.2	0.3	0.3-0.4	M 1
2.2	0.1-0.2	0.2	0.2	0.3	0.3-0.4	M 3
2.3	0.1-0.2	0.2	0.2	0.3	0.3-0.4	M 2
2.4	0.1-0.2	0.2	0.2	0.3	0.3-0.4	S 2
3.1	0.1-0.2	0.2	0.2-0.3	0.3-0.4	0.4-0.5	K 1
3.2	0.1-0.2	0.2	0.2-0.3	0.3-0.4	0.4-0.5	K 2
3.3	0.1-0.2	0.2	0.3	0.4	0.5	K 3
3.4	0.1-0.2	0.2	0.3	0.4	0.5	K 4
4.1	0.1-0.2	0.2	0.2-0.3	0.3-0.4	0.3-0.4	S 1
4.2	0.1-0.2	0.2	0.2	0.3	0.3-0.4	S 2
4.3	0.1-0.2	0.2	0.2	0.3	0.3-0.4	S 3
5.1	0.1-0.2	0.2	0.2-0.3	0.3-0.4	0.4-0.5	S 1
5.2	0.1-0.2	0.2	0.2	0.3	0.3-0.4	S 2
5.3	0.1-0.2	0.2	0.2	0.3	0.3-0.4	S 3
6.1	0.1-0.2	0.2-0.3	0.3-0.4	0.4-0.5	0.5	N 3
6.2	0.1-0.2	0.2	0.2-0.3	0.3	0.3-0.4	N 4
6.3	0.1-0.2	0.2	0.2-0.3	0.3	0.3-0.4	N 3
6.4	0.1-0.2	0.2	0.2-0.3	0.3	0.3-0.4	N 4
7.1	0.1-0.2	0.2-0.3	0.3-0.4	0.4-0.5	0.5	N 1
7.2	0.1-0.2	0.2-0.3	0.3-0.4	0.4-0.5	0.5	N 1
7.3	0.1-0.2	0.2-0.3	0.3-0.4	0.4-0.5	0.5	N 1
7.4	0.1-0.2	0.2-0.3	0.3-0.4	0.4-0.5	0.5	N 2
8.1	0.1-0.2	0.3	0.4	0.4-0.5	0.5	O
8.2	0.1-0.2	0.2	0.2	0.3	0.3-0.4	O
8.3	0.1-0.2	0.2	0.2	0.3	0.3-0.4	O
9.1	0.1-0.2	0.2	0.2	0.3	0.3-0.4	H
10.1	0.1-0.2	0.2	0.2-0.3	0.3-0.4	0.4-0.5	O

Per alesatori regolabili o a lame ridurre il valore di sovrametallo del 30%. Per alesatori a forte torsione incrementare il sovrametallo del 50% / Für verstellbare Reibahlen Reibaufmass um 30 % reduzieren. Für Schälreibahlen um 50 % erhöhen. / Voor verstelbare ruimers de materiaal afname met 30% reduceren. Voor schilruimers met 50% verhogen. / Pour les alésoirs expansibles ou brasés réduire l'avance de 30%. Pour les alésoirs à hélice rapide augmenter de 50%.

B400

- Alesatore a macchina con spaziatura asimmetrica accentuata dei taglienti
- Maschinenreibahle, extrem ungleiche Teilung
- Machineruimer Differentialaal vertand
- Alésoir machine Pas inégal

B400	▪	1.5	1.6	3.1	3.2	3.3	3.4	4.1	4.2	4.3	5.1	5.2	5.3	6.1	6.2	6.3	6.4	7.1	7.2	7.3	7.4	
		8.1	8.2																			
	•	1.1	1.2	1.3	1.4																	

B400 **HM**   **H7**

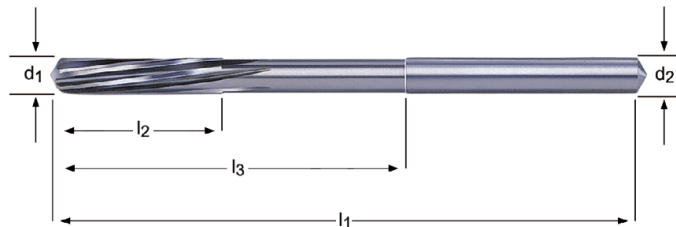

d_1 Ø mm	l_1 mm	l_2 mm	l_3 mm	z	d_2 Ø h_7 mm	B400
1.0	34	6	15	3	1.0	B4001.0 ¹⁾
1.2	38	8	16.5	3	1.2	B4001.2 ¹⁾
1.4	40	8	18	3	1.4	B4001.4 ¹⁾
1.5	40	8	18	3	1.5	B4001.5 ¹⁾
1.6	49	11	26	3	1.6	B4001.6 ¹⁾
1.8	49	11	25	4	1.8	B4001.8 ¹⁾
2.0	49	11	24	4	2.0	B4002.0 ¹⁾
2.2	57	15	30	4	2.2	B4002.2 ¹⁾
2.5	57	15	28	4	2.5	B4002.5 ¹⁾
2.8	61	15	32	4	2.8	B4002.8 ¹⁾
3.0	61	15	30	6	3.0	B4003.0 ¹⁾
3.2	70	18	33	6	3.2	B4003.2 ¹⁾
3.5	70	18	33	6	3.5	B4003.5 ¹⁾
4.0	75	19	44	6	4.0	B4004.0 ¹⁾
4.5	80	21	46	6	4.5	B4004.5 ¹⁾
5.0	86	23	53	6	5.0	B4005.0 ¹⁾
5.5	93	26	56	6	5.6	B4005.5 ¹⁾
6.0	93	26	56	6	5.6	B4006.0 ¹⁾
6.5	101	28	63	6	6.3	B4006.5 ²⁾
7.0	109	31	69	6	7.1	B4007.0 ²⁾
8.0	117	33	75	6	8.0	B4008.0 ²⁾
9.0	125	36	81	6	9.0	B4009.0 ²⁾
10.0	133	38	87	6	10.0	B40010.0 ²⁾
12.0	151	44	105	6	10.0	B40012.0 ²⁾
14.0	160	47	110	8	12.5	B40014.0 ²⁾
16.0	170	52	120	8	12.5	B40016.0 ²⁾
18.0	182	56	130	6	14.0	B40018.0 ³⁾
20.0	195	60	137	6	16.0	B40020.0 ³⁾

¹⁾ Metallo Duro / VHM / Volhardmetalen machineruimer / Carbure monobloc

²⁾ Testa in metallo duro / VHM-Kopf / VHM kop / Tête carbure

³⁾ Parte frontale in metallo duro / Vollhartmetallbestückt / VHM tip / Pointe carbure

B481

- Alesatore centesimale per macchine a CN, con codolo per mandrini ad alta precisione
- NC- 1/100 Reibahle für Hochgenauigkeitsfutter
- NC-1/100 ruimer
- NC - Alésoir au centième pour mandrins haute précision

Spazio tra i taglienti asimmetrico
 Extrem ungleiche Teilung
 Differentialaal vertand
 Pas différentiel

B481	▪	1.5	1.6	3.1	3.2	3.3	3.4	4.1	4.2	4.3	5.1	5.2	5.3	6.1	6.2	6.3	6.4	7.1	7.2	7.3	7.4	
		8.1	8.2																			
	•	1.1	1.2	1.3	1.4																	

B481

HM



DIN
8093



DIN
6535HA

B

Ø.95-5.5
0,+0.004
Ø5.51-12
0,+0.005



B481



0.98 - 12.05

d_1 Ø mm	l_1 mm	l_2 mm	l_3 mm	z	d_2 Ø h_6 mm	B481
0.98	49.5	6	21.5	3	4	B4810.98
0.99	49.5	6	21.5	3	4	B4810.99
1.00	49.5	6	21.5	3	4	B4811.00
1.01	49.5	6	21.5	3	4	B4811.01
1.02	49.5	6	21.5	3	4	B4811.02
1.03	49.5	9	21.5	3	4	B4811.03
1.48	49	9	21	3	4	B4811.48
1.49	49	9	21	3	4	B4811.49
1.50	49	9	21	3	4	B4811.50
1.51	49	9	21	3	4	B4811.51
1.52	49	9	21	3	4	B4811.52
1.53	49	9	21	3	4	B4811.53
1.98	49	12	21	4	4	B4811.98
1.99	49	12	21	4	4	B4811.99
2.00	49	12	21	4	4	B4812.00
2.01	49	12	21	4	4	B4812.01
2.02	49	12	21	4	4	B4812.02
2.03	49	12	21	4	4	B4812.03
2.48	59	16	31	4	4	B4812.48
2.49	59	16	31	4	4	B4812.49
2.50	59	16	31	4	4	B4812.50
2.51	59	16	31	4	4	B4812.51
2.52	59	16	31	4	4	B4812.52
2.53	59	16	31	4	4	B4812.53
2.97	62.5	17	35	6	4	B4812.97
2.98	62.5	17	35	6	4	B4812.98
2.99	62.5	17	35	6	4	B4812.99
3.00	62.5	17	35	6	4	B4813.00
3.01	62.5	17	35	6	4	B4813.01
3.02	62.5	17	35	6	4	B4813.02
3.03	62.5	17	35	6	4	B4813.03
3.97	75	19	47	6	4	B4813.97
3.98	75	19	47	6	4	B4813.98
3.99	75	19	47	6	4	B4813.99
4.00	75	19	47	6	4	B4814.00
4.01	75	19	47	6	4	B4814.01
4.02	75	19	47	6	4	B4814.02
4.03	75	19	47	6	4	B4814.03

d_1 Ø mm	l_1 mm	l_2 mm	l_3 mm	z	d_2 Ø h_6 mm	B481
4.97	86	23	50	6	6	B4814.97
4.98	86	23	50	6	6	B4814.98
4.99	86	23	50	6	6	B4814.99
5.00	86	23	50	6	6	B4815.00
5.01	86	23	50	6	6	B4815.01
5.02	86	23	50	6	6	B4815.02
5.03	86	23	50	6	6	B4815.03
5.97	93	26	57	6	6	B4815.97
5.98	93	26	57	6	6	B4815.98
5.99	93	26	57	6	6	B4815.99
6.00	93	26	57	6	6	B4816.00
6.01	93	26	57	6	6	B4816.01
6.02	93	26	57	6	6	B4816.02
6.03	93	26	57	6	6	B4816.03
7.97	117	33	81	6	8	B4817.97
7.98	117	33	81	6	8	B4817.98
7.99	117	33	81	6	8	B4817.99
8.00	117	33	81	6	8	B4818.00
8.01	117	33	81	6	8	B4818.01
8.02	117	33	81	6	8	B4818.02
8.03	117	33	81	6	8	B4818.03
8.04	117	33	81	6	8	B4818.04
9.97	133	38	93	6	10	B4819.97
9.98	133	38	93	6	10	B4819.98
9.99	133	38	93	6	10	B4819.99
10.00	133	38	93	6	10	B48110.00
10.01	133	38	93	6	10	B48110.01
10.02	133	38	93	6	10	B48110.02
10.03	133	38	93	6	10	B48110.03
10.04	133	38	93	6	10	B48110.04
10.05	133	38	93	6	10	B48110.05
11.97	151	44	106	6	12	B48111.97
11.98	151	44	106	6	12	B48111.98
11.99	151	44	106	6	12	B48111.99
12.00	151	44	106	6	12	B48112.00
12.01	151	44	106	6	12	B48112.01
12.02	151	44	106	6	12	B48112.02
12.03	151	44	106	6	12	B48112.03
12.04	151	44	106	6	12	B48112.04
12.05	151	44	106	6	12	B48112.05

- B441**
- Alesatore a macchina con spaziatura asimmetrica accentuata dei taglienti
 - Maschinenreibahle, extrem ungleiche Teilung
 - Machineruimer differentiaal vertand
 - Alésoir machine Pas inégal

B441	▪	1.5	1.6	3.1	3.2	3.3	3.4	4.1	4.2	4.3	5.1	5.2	5.3	6.1	6.2	6.3	6.4	7.1	7.2	7.3	7.4	
		8.1	8.2																			
	•	1.1	1.2	1.3	1.4																	

B441

HM

DIN
8050

A

H7

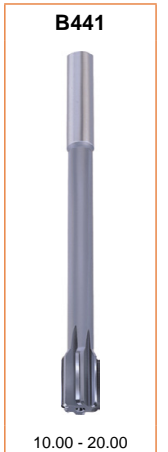
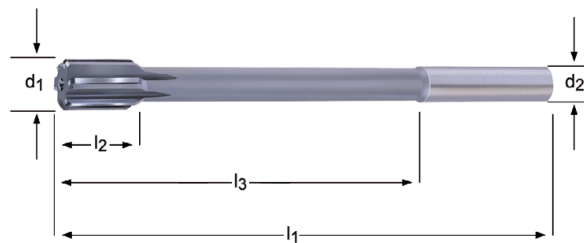

d_1 Ø mm	l_1 mm	l_2 mm	l_3 mm	z	d_2 Ø _{h9} mm	B441
10.0	133	19	87	6	10	B44110.0 ³⁾
11.0	142	19	96	6	10	B44111.0 ³⁾
12.0	151	19	105	6	10	B44112.0 ³⁾
13.0	151	19	105	6	10	B44113.0 ³⁾
14.0	160	19	110	6	12.5	B44114.0 ³⁾
15.0	162	19	112	6	12.5	B44115.0 ³⁾
16.0	170	22	120	6	12.5	B44116.0 ³⁾
17.0	175	22	123	6	14	B44117.0 ³⁾
18.0	182	22	130	6	14	B44118.0 ³⁾
19.0	189	22	131	6	16	B44119.0 ³⁾
20.0	195	22	137	6	16	B44120.0 ³⁾

³⁾ Parte frontale in metallo duro / Vollhartmetallbestückt / VHM tip / Pointe carbure

- B411**
- Alesatore a macchina con spaziatura asimmetrica accentuata dei taglienti
 - Maschinenreibahle, extrem ungleiche Teilung
 - Machineruimer differentiaal vertand
 - Alésoir machine Pas inégal

B411	▪	1.5	1.6	3.1	3.2	3.3	3.4	4.1	4.2	4.3	5.1	5.2	5.3	6.1	6.2	6.3	6.4	7.1	7.2	7.3	7.4	
		8.1	8.2																			
		•	1.1	1.2	1.3	1.4																

B411

HM

DIN
8094

B

H7



d_1 Ø mm	l_1 mm	l_2 mm	l_3 mm	z	MK	B411
5.0	133	23	67.5	6	1	B4115.0 ²⁾
6.0	138	26	72.5	6	1	B4116.0 ²⁾
7.0	150	31	84.5	6	1	B4117.0 ²⁾
8.0	156	33	90.5	6	1	B4118.0 ²⁾
9.0	162	36	96.5	6	1	B4119.0 ²⁾
10.0	168	38	102.5	6	1	B41110.0 ²⁾
12.0	182	44	116.5	6	1	B41112.0 ²⁾
14.0	189	47	123.5	8	1	B41114.0 ²⁾
15.0	204	50	124	8	2	B41115.0 ²⁾
16.0	210	52	130	8	2	B41116.0 ²⁾
17.0	214	54	134	6	2	B41117.0 ³⁾
18.0	219	56	139	6	2	B41118.0 ³⁾
19.0	223	58	143	6	2	B41119.0 ³⁾
20.0	228	60	148	6	2	B41120.0 ³⁾
22.0	237	64	157	6	2	B41122.0 ³⁾
24.0	268	68	169	8	3	B41124.0 ³⁾
25.0	268	68	169	8	3	B41125.0 ³⁾
26.0	273	70	174	8	3	B41126.0 ³⁾
30.0	281	73	182	8	3	B41130.0 ³⁾

²⁾ Testa in metallo duro / VHM-Kopf / VHM kop / Tête carbure
³⁾ Parte frontale in metallo duro / Vollhartmetallbestückt / VHM tip / Pointe carbure

- B442**
- Alesatore a macchina con spaziatura asimmetrica accentuata dei taglienti
 - Maschinenreibahle, extrem ungleiche Teilung
 - Machineruimer differentiaal vertand
 - Alésoir machine Pas inégal

B442	▪	1.5	1.6	3.1	3.2	3.3	3.4	4.1	4.2	4.3	5.1	5.2	5.3	6.1	6.2	6.3	6.4	7.1	7.2	7.3	7.4	
		8.1	8.2																			
	•	1.1	1.2	1.3	1.4																	

B442

HM

DIN
8051

A

H7

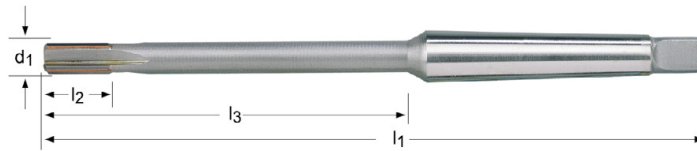

d_1 \varnothing mm	l_1 mm	l_2 mm	l_3 mm	z	MK	B442
10.0	168	19	102.5	6	1	B44210.0
12.0	182	19	116.5	6	1	B44212.0
14.0	189	19	123.5	6	1	B44214.0
15.0	204	19	124	6	2	B44215.0
16.0	210	22	130	6	2	B44216.0
17.0	214	22	134	6	2	B44217.0
18.0	219	22	139	6	2	B44218.0
19.0	223	22	143	6	2	B44219.0
20.0	228	22	148	6	2	B44220.0

B100

- Alesatore a mano
- Handreibahle
- Handruimer
- Alésoir à main

d2=d1 con tolleranza e9
 d2=d1 mit Toleranz e9
 d2=d1 met tolerantie e9
 d2=d1 avec tolérance e9

B100	▪	1.1	1.2	1.3	1.4	2.1	3.1	4.1	6.2								
	•	1.5	1.6	3.2	3.3	3.4	4.2	4.3	5.1	5.2	5.3	6.1	6.3	6.4	7.1	7.2	8.2

B100 HSS ST **DIN 206**   **B** **H7**



B100



1.50 - 50.00

d ₁ Ø Inch	d ₁ Ø mm	l ₁ mm	l ₂ mm	l ₃ mm	z	∇ a mm	B100
	1.50	41	20	5	3	1.12	B1001.5
1/16	1.59	41	20	5	3	1.12	B1001/16
	1.60	44	21	5	3	1.25	B1001.6
5/64	1.98	47	23	6	4	1.40	B1005/64
	2.00	50	25	6	4	1.60	B1002.0
3/32	2.38	54	27	7	4	1.80	B1003/32
	2.50	58	29	7	4	2.10	B1002.5
7/64	2.78	62	31	8	6	2.10	B1007/64
	3.00	62	31	8	6	2.40	B1003.0
1/8	3.18	66	33	8	6	2.40	B1001/8
	3.20	66	33	8	6	2.40	B1003.2
	3.50	71	35	9	6	2.70	B1003.5
9/64	3.57	71	35	9	6	2.70	B1009/64
5/32	3.97	76	38	10	6	3.00	B1005/32
	4.00	76	38	10	6	3.00	B1004.0
11/64	4.37	81	41	10	6	3.40	B10011/64
	4.50	81	41	10	6	3.40	B1004.5
3/16	4.76	87	44	11	6	3.80	B1003/16
	5.00	87	44	11	6	3.80	B1005.0
13/64	5.16	87	44	11	6	3.80	B10013/64
	5.50	93	47	12	6	4.30	B1005.5
7/32	5.56	93	47	12	6	4.30	B1007/32
15/64	5.95	93	47	12	6	4.90	B10015/64
	6.00	93	47	12	6	4.90	B1006.0
1/4	6.35	100	50	13	6	4.90	B1001/4
	6.50	100	50	13	6	4.90	B1006.5
17/64	6.75	107	54	14	6	5.50	B10017/64
	7.00	107	54	14	6	5.50	B1007.0
9/32	7.14	107	54	14	6	6.20	B1009/32
	7.50	107	54	14	6	6.20	B1007.5
19/64	7.54	115	58	15	6	6.20	B10019/64
5/16	7.94	115	58	15	6	6.20	B1005/16
	8.00	115	58	15	6	6.20	B1008.0
21/64	8.33	115	58	15	6	7.00	B10021/64
	8.50	115	58	15	6	7.00	B1008.5
11/32	8.73	124	62	16	6	7.00	B10011/32
	9.00	124	62	16	6	7.00	B1009.0
23/64	9.13	124	62	16	6	8.00	B10023/64
	9.50	124	62	16	6	8.00	B1009.5
3/8	9.52	124	62	17	6	8.00	B1003/8

d₁ Ø Inch	d₁ Ø mm	l₁ mm	l₂ mm	l₃ mm	z	□ a mm	B100
25/64	9.92	133	66	17	6	8.00	B10025/64
	10.00	133	66	17	6	8.00	B10010.0
13/32	10.32	133	66	17	6	8.00	B10013/32
	10.50	133	66	17	6	8.00	B10010.5
	11.00	142	71	18	6	9.00	B10011.0
7/16	11.11	142	71	18	6	9.00	B1007/16
	11.50	142	71	18	6	9.00	B10011.5
	12.00	152	76	19	6	9.00	B10012.0
	12.50	152	76	19	6	10.00	B10012.5
1/2	12.70	152	76	19	6	10.00	B1001/2
	13.00	152	76	19	6	10.00	B10013.0
17/32	13.49	163	81	20	8	11.00	B10017/32
	13.50	163	81	20	8	11.00	B10013.5
	14.00	163	81	20	8	11.00	B10014.0
9/16	14.29	163	81	20	8	11.00	B1009/16
	14.50	163	81	20	8	11.00	B10014.5
	15.00	163	81	20	8	12.00	B10015.0
19/32	15.08	163	81	22	8	12.00	B10019/32
5/8	15.88	175	87	22	8	12.00	B1005/8
	16.00	175	87	22	8	12.00	B10016.0
	17.00	175	87	22	8	13.00	B10017.0
11/16	17.46	188	93	23	8	14.50	B10011/16
	18.00	188	93	23	8	14.50	B10018.0
	19.00	188	93	23	8	14.50	B10019.0
3/4	19.05	188	93	25	8	14.50	B1003/4
	20.00	201	100	25	8	16.00	B10020.0
13/16	20.64	201	100	25	8	16.00	B10013/16
	21.00	201	100	25	8	16.00	B10021.0
	22.00	215	107	27	8	18.00	B10022.0
7/8	22.22	215	107	27	8	18.00	B1007/8
	23.00	215	107	27	8	18.00	B10023.0
	24.00	231	115	29	8	18.00	B10024.0
	25.00	231	115	29	8	20.00	B10025.0
1"	25.40	231	115	29	8	20.00	B1001
	26.00	231	115	29	8	20.00	B10026.0
	27.00	247	124	31	10	22.00	B10027.0
	28.00	247	124	31	10	22.00	B10028.0
	29.00	247	124	31	10	22.00	B10029.0
	30.00	247	124	31	10	24.00	B10030.0
	31.00	265	133	33	10	24.00	B10031.0
	32.00	265	133	33	10	24.00	B10032.0
	33.00	265	133	33	10	26.00	B10033.0
	34.00	284	142	36	10	26.00	B10034.0
	35.00	284	142	36	10	29.00	B10035.0
	36.00	284	142	36	10	29.00	B10036.0
	37.00	284	142	36	10	29.00	B10037.0
	38.00	305	152	38	10	29.00	B10038.0
	39.00	305	152	38	10	32.00	B10039.0
	40.00	305	152	38	10	32.00	B10040.0
	45.00	326	163	41	12	35.00	B10045.0
	50.00	347	174	44	12	39.00	B10050.0

- B334**
- Alesatori a mano a grande espansione
 - Handreibahle verstellbar, mit austauschbaren Messern
 - Verstellbare ruimer
 - Alésoirs à main expansibles

B334	▪	1.1	1.2	1.3	1.4	2.1	3.1	4.1	6.2								
	•	1.5	1.6	3.2	3.3	3.4	4.2	4.3	5.1	5.2	5.3	6.1	6.3	6.4	7.1	7.2	8.2

B334 HSS

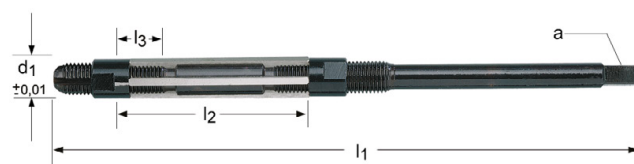

B334



N000 - N16

Nr.	d min-max mm	l ₁ mm	l ₂ mm	l ₃ mm	z	∇ a mm	B334
000	6.4 - 7.2	110	32	7	4	3.0	B334000
00	7.2 - 8.0	110	32	7	4	3.4	B33400
0	8.0 - 9.0	115	34	9	5	3.8	B3340
1	9.0 - 10.0	115	34	9	5	4.3	B3341
2	10.0 - 11.0	115	34	9	5	4.9	B3342
3	11.0 - 12.0	125	35	9	5	4.9	B3343
4	12.0 - 13.5	135	41	9	5	6.2	B3344
5	13.5 - 15.5	146	50	12	5	7.0	B3345
6	15.5 - 18.0	166	60	12	5	8.0	B3346
7	18.0 - 21.0	178	65	15	5	9.0	B3347
8	21.0 - 24.0	195	76	15	5	11.0	B3348
9	24.0 - 27.5	218	82	18	5	12.0	B3349
10	27.5 - 31.5	245	86	18	5	14.5	B33410
11	31.5 - 37.0	280	98	18	6	18.0	B33411
12	37.0 - 45.0	325	108	20	6	20.0	B33412
13	45.0 - 55.0	370	118	20	6	26.0	B33413
14	55.0 - 67.0	400	125	20	6	32.0	B33414
15	67.0 - 80.0	435	140	23	8	39.0	B33415
16	80.0 - 95.0	475	155	23	8	49.0	B33416

- B335**
- Alesatori a mano a grande espansione - ricambi (B334)
 - Ersatzmessersätze und Verstellmutter für Handreibahlen verstellbar B334
 - Verstellbare handruimer - reserve onderdelen (B334)
 - Accessoires pour alésoirs à main expansibles (B334)



BLADES



NUT



Nr.	B335
000	B335000BLADES
000	B335000NUT
00	B33500BLADES
00	B33500NUT
0	B3350BLADES
0	B3350NUT
1	B3351BLADES
1	B3351NUT
2	B3352BLADES
2	B3352NUT
3	B3353BLADES
3	B3353NUT
4	B3354BLADES
4	B3354NUT
5	B3355BLADES
5	B3355NUT
6	B3356BLADES
6	B3356NUT
7	B3357BLADES
7	B3357NUT
8	B3358BLADES
8	B3358NUT
9	B3359BLADES
9	B3359NUT
10	B33510BLADES
10	B33510NUT
11	B33511BLADES
11	B33511NUT
12	B33512BLADES
12	B33512NUT
13	B33513BLADES
13	B33513NUT
14	B33514BLADES
14	B33514NUT
15	B33515BLADES
15	B33515NUT
16	B33516BLADES
16	B33516NUT

- B901**
- Alesatore a macchina
 - Maschinenreibahle
 - Machineruimer
 - Alésoir machine conique pour trous de goupilles

d2=d1 - 0.025
d2=d1 - 0.025
d2=d1 - 0.025
d2=d1 - 0.025

B901	▪	1.1	1.2	1.3	1.4	2.1	3.1	4.1	6.2							
	•	1.5	1.6	3.2	3.3	3.4	4.2	4.3	5.1	5.2	5.3	6.1	6.3	6.4	7.1	7.2

B901 HSS-E     **B** **H7**

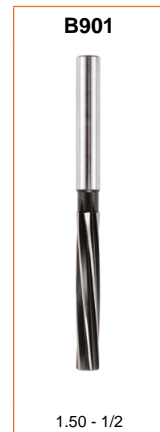

d ₁ Ø Inch	d ₁ Ø mm	l ₁ mm	l ₂ mm	z	B901
	1.50	44	21	4	B9011.5
1/16	1.59	44	21	4	B9011/16
	2.00	50	25	4	B9012.0
3/32	2.38	58	29	4	B9013/32
	2.50	58	29	4	B9012.5
	3.00	62	31	4	B9013.0
1/8	3.18	66	33	4	B9011/8
	3.50	71	35	4	B9013.5
5/32	3.97	76	38	6	B9015/32
	4.00	76	38	6	B9014.0
	4.50	81	41	6	B9014.5
3/16	4.76	87	44	6	B9013/16
	5.00	87	44	6	B9015.0
13/64	5.16	87	44	6	B90113/64
	5.50	93	47	6	B9015.5
7/32	5.56	93	47	6	B9017/32
15/64	5.95	93	47	6	B90115/64
	6.00	93	47	6	B9016.0
1/4	6.35	100	50	6	B9011/4
	7.00	107	54	6	B9017.0
9/32	7.14	107	54	6	B9019/32
5/16	7.94	115	58	6	B9015/16
	8.00	115	58	6	B9018.0
	9.00	124	62	6	B9019.0
3/8	9.52	133	66	6	B9013/8
	10.00	133	66	6	B90110.0
	11.00	142	71	6	B90111.0
7/16	11.11	142	71	6	B9017/16
	12.00	152	76	6	B90112.0
1/2	12.70	152	76	6	B9011/2

B301

- Alesatore a mano per fori di spine coniche
- Hand-Kegelreibahle, gerade genutet
- Pengat handruimer
- Alésoir à main conique

B301	▪	1.1	1.2	1.3	1.4	2.1	3.1	4.1	6.2										
	•	1.5	1.6	2.2	2.3	3.2	3.3	3.4	4.2	4.3	5.1	6.1	6.3	6.4	7.1	7.2	7.3	7.4	8.2

B301 HSS

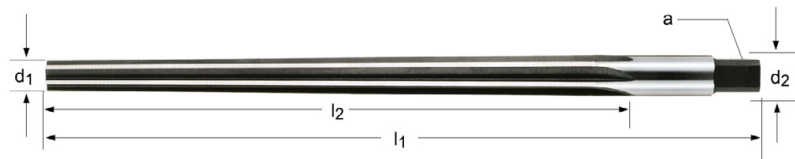

nom Ø	d ₁ Ø mm	l ₁ mm	l ₂ mm	z	∇ a mm	d ₂ Ø mm	B301
1/16	1.10	51	25	4	1.2	1.63	B3011/16 ⁴⁾
5/64	1.50	51	25	4	1.6	2.03	B3015/64 ⁴⁾
3/32	1.75	57	32	4	2.0	2.41	B3013/32 ⁴⁾
7/64	2.03	64	38	4	2.2	2.82	B3017/64 ⁴⁾
1/8	2.30	70	44	4	2.5	3.23	B3011/8 ⁴⁾
9/64	2.64	73	48	4	2.8	3.63	B3019/64 ⁴⁾
5/32	2.95	76	51	4	3.1	4.01	B3015/32 ⁴⁾
11/64	3.23	89	57	4	3.6	4.42	B30111/64 ⁴⁾
3/16	3.50	102	70	4	4.0	4.95	B3013/16 ⁴⁾
7/32	4.13	102	70	6	4.5	5.59	B3017/32 ⁴⁾
1/4	4.64	117	86	6	5.0	6.43	B3011/4 ⁵⁾
9/32	5.23	143	105	6	5.6	7.42	B3019/32 ⁵⁾
5/16	5.84	143	105	6	6.3	8.03	B3015/16 ⁵⁾
11/32	6.43	152	114	6	7.1	8.81	B30111/32 ⁵⁾
3/8	7.03	165	127	6	8.0	9.68	B3013/8 ⁵⁾
13/32	7.42	191	146	6	8.0	10.46	B30113/32 ⁵⁾
7/16	8.21	191	146	6	9.0	11.25	B3017/16 ⁵⁾
1/2	9.41	210	165	6	10.0	12.85	B3011/2 ⁵⁾

⁴⁾ Limite di tolleranza +0.0040 / Toleranz +0.0030 / Tolerantie +0.0030 / Tolérance +0.0030

⁵⁾ Limite di tolleranza +0.0050 / Toleranz +0.0050 / Tolerantie +0.0050 / Tolérance +0.0050

B903

- Alesatore a mano per fori di spine coniche
- Hand-Kegelreibahle, gerade genutet
- Pengat handruimer
- Alésoir à main conique

B903	▪	1.1	1.2	1.3	1.4	2.1	3.1	4.1	6.2										
	•	1.5	1.6	2.2	2.3	3.2	3.3	3.4	4.2	4.3	5.1	6.1	6.3	6.4	7.1	7.2	7.3	7.4	8.2

B903 HSS ST DIN 9   A  1:50



B903



1.50 - 20.00

nom Ø	d ₁ Ø mm	d ₂ Ø mm	l ₁ mm	l ₂ mm	z	∇ a mm	d ₃ Ø _{h₁₁} mm	B903
1.5	1.40	2.14	57	37	4	1.80	2.14	B9031.5 ⁶⁾
2.0	1.90	2.86	68	48	4	2.24	2.86	B9032.0 ⁶⁾
2.5	2.40	3.36	68	48	4	2.80	3.36	B9032.5 ⁶⁾
3.0	2.90	4.06	80	58	4	3.15	4.00	B9033.0 ⁶⁾
4.0	3.90	5.26	93	68	4	4.00	5.00	B9034.0 ⁶⁾
5.0	4.90	6.36	100	73	4	5.00	6.30	B9035.0 ⁶⁾
6.0	5.90	8.00	135	105	6	6.30	7.90	B9036.0 ⁷⁾
8.0	7.90	10.80	180	145	6	8.00	10.50	B9038.0 ⁷⁾
10.0	9.90	13.40	215	175	6	10.00	13.30	B90310.0 ⁷⁾
12.0	11.80	16.00	255	210	8	11.20	16.00	B90312.0 ⁷⁾
13.0	12.86	16.74	255	210	8	12.50	16.74	B90313.0 ⁷⁾
14.0	13.86	17.74	255	210	8	12.50	17.74	B90314.0 ⁷⁾
16.0	15.80	20.40	280	230	8	14.00	20.40	B90316.0 ⁷⁾
20.0	19.80	24.80	310	250	8	18.00	24.80	B90320.0 ⁷⁾

⁶⁾ Limite di tolleranza +0.0750 / Toleranz +0.0750 / Tolerantie +0.0750 / Tolérance +0.0750

⁷⁾ Limite di tolleranza +0.125 / Toleranz +0.125 / Tolerantie +0.125 / Tolérance +0.125

B952

- Alesatore a mano per fori di spine coniche
- Hand-Kegelreibahle, gerade genutet
- Pengat handruimer
- Alésoir à main conique

B952 ■ 1.1 1.2 1.3 1.4 2.1 3.1 4.1 6.2
 • 1.5 1.6 2.2 2.3 3.2 3.3 3.4 4.2 4.3 5.1 6.1 6.3 6.4 7.1 7.2 7.3 7.4 8.2

B952 HSS DIN 9 B 1:50

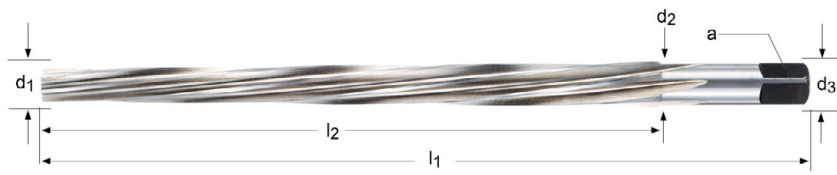

nom Ø	d_1 Ø mm	d_2 Ø mm	l_1 mm	l_2 mm	z	\square a mm	d_3 Ø h_{11} mm	B952
1.2	1.1	1.74	50	32	3	2.4	3.15	B9521.2 ⁸⁾
1.5	1.4	2.14	57	37	3	2.4	3.15	B9521.5 ⁸⁾
2.0	1.9	2.86	68	48	3	2.4	3.15	B9522.0 ⁸⁾
2.5	2.4	3.36	68	48	4	2.4	3.15	B9522.5 ⁸⁾
3.0	2.9	4.06	80	58	5	3.0	4.00	B9523.0
3.5	3.4	4.66	87	63	5	3.4	4.50	B9523.5
4.0	3.9	5.26	93	68	5	3.8	5.00	B9524.0
4.5	4.4	5.80	95	70	5	4.3	5.60	B9524.5
5.0	4.9	6.36	100	73	5	4.9	6.30	B9525.0
5.5	5.4	7.20	118	90	6	5.5	7.10	B9525.5
6.0	5.9	8.00	135	105	6	6.2	8.00	B9526.0
6.5	6.4	8.60	140	110	6	6.2	8.00	B9526.5
7.0	6.9	9.40	160	125	6	7.0	9.00	B9527.0
8.0	7.9	10.8	180	145	6	8.0	10.00	B9528.0
9.0	8.9	12.1	195	160	6	9.0	11.20	B9529.0
10.0	9.9	13.4	215	175	6	10.0	12.50	B95210.0
12.0	11.8	16.0	255	210	8	11.0	14.00	B95212.0
13.0	12.8	17.0	255	210	8	12.0	16.00	B95213.0
14.0	13.8	18.0	255	210	8	12.0	16.00	B95214.0
16.0	15.8	20.4	280	230	8	14.5	18.00	B95216.0
20.0	19.8	24.8	310	250	8	18.0	22.40	B95220.0
25.0	24.7	30.7	370	300	10	22.0	28.00	B95225.0
30.0	29.7	36.1	400	320	10	24.0	31.50	B95230.0
40.0	39.7	46.5	430	340	12	32.0	40.00	B95240.0
50.0	49.7	56.9	460	360	12	39.0	50.00	B95250.0

⁸⁾ Codolo diritto, forma A / Gerade genutet, form A / Rechte spaangroef, vorm A / Goujure droite, forme A

- B122**
- Diritto Alesatori a macchina
 - Karroserie Reibahle mit Zylinderschaft
 - Carrosserieruimer
 - Alésoir cylindrique tôle fine, hélice à gauche

B122	▪	1.1	1.2	1.3	1.4	2.1	3.1	4.1	6.2											
	•	1.5	1.6	2.2	2.3	3.2	3.3	3.4	4.2	4.3	5.1	6.1	6.3	6.4	7.1	7.2	7.3	7.4	8.2	

B122 HSS



ANSI

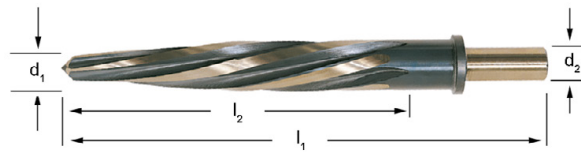

B122



3/8 - 1.1/16

d_1 Ø Inch	d_1 decimal Inch	l_1 Inch	l_2 Inch	z	d_2 Ø Inch	B122
3/8	0.3750	4.5/8	2.1/2	4	3/8	B1223/8
1/2	0.5000	5.7/8	3.3/4	5	1/2	B1221/2
9/16	0.5625	5.7/8	3.3/4	5	1/2	B1229/16
5/8	0.6250	6.3/8	4.1/4	5	1/2	B1225/8
11/16	0.6875	6.3/8	4.1/4	5	1/2	B12211/16
3/4	0.7500	6.7/8	4.1/2	5	1/2	B1223/4
13/16	0.8125	6.7/8	4.1/2	5	1/2	B12213/16
7/8	0.8750	6.7/8	4.1/2	5	1/2	B1227/8
15/16	0.9375	6.7/8	4.1/2	5	1/2	B12215/16
1"	1.0000	6.7/8	4.1/2	5	1/2	B1221
1.1/16	1.0625	6.7/8	4.1/2	5	1/2	B1221.1/16

- # B953
- Alesatore a macchina per spine coniche ad elica sinistra 45°
 - Maschinen-Kegelreibahle mit 45° linksdrall
 - Machine-pengatruimer met 45° linkse spiraal
 - Alésoir Machine pour goupille conique Hélice à gauche à 45°

Tenone secondo DiN 1809
mit Mitnehmer DIN 1809
Met lip DIN 1809
Tenon selon la DIN 1809

B953 ■ 2.1 2.2 2.3 4.1 4.2 4.3 5.1 5.2 5.3 6.1 7.1 7.2 7.3 7.4 8.1
• 1.1 1.2 1.3 1.4 1.5 1.6 6.2 9.1

B953 HSS-E 1:50

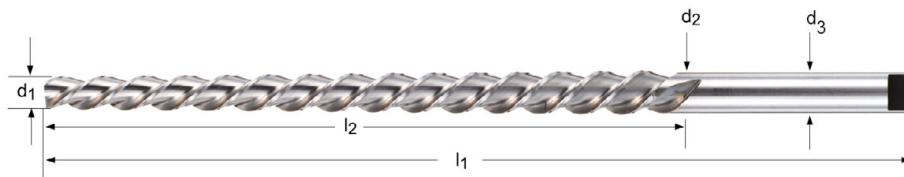

nom Ø	d_1 Ø mm	d_2 Ø mm	l_1 mm	l_2 mm	z	d_3 Ø _{h₃} mm	B953
1.0	0.8	1.46	60	33	2	1.4	B9531.0
1.5	1.4	2.14	70	37	2	2.1	B9531.5
2.0	1.9	2.86	86	48	3	3.15	B9532.0
2.5	2.4	3.36	86	48	3	3.15	B9532.5
3.0	2.9	4.06	100	58	3	4.0	B9533.0
4.0	3.9	5.26	112	68	3	5.0	B9534.0
5.0	4.9	6.36	122	73	3	6.3	B9535.0
6.0	5.9	8.00	160	105	3	8.0	B9536.0
6.5	6.4	8.78	188	119	3	8.5	B9536.5
8.0	7.9	10.80	207	145	3	10.0	B9538.0
10.0	9.9	13.40	245	175	3	12.5	B95310.0
12.0	11.8	16.00	290	210	3	16.0	B95312.0

B180

- Alesatori CN per mandrini ad elevata precisione
- NC-Maschinen-Reibahle
- NC-precisieruimer
- Alésoir de précision - NC

B180	▪	1.1	1.2	1.3	1.4	2.1	4.2	5.1											
	•	1.5	1.6	2.2	2.3	2.4	3.1	3.2	3.3	3.4	4.1	4.3	5.2	5.3	6.1	6.2	6.3	6.4	

B180 HSS-E



DIN
212



DIN
6535HA

B

H7



B180



1.50 - 20.0

d_1 Ø mm	l_1 mm	l_2 mm	l_3 mm	z	d_2 Ø _{h6} mm	B180
1.5	40	8	18	3	2	B1801.5
1.6	43	9	20	3	2	B1801.6
1.7	43	9	20	3	2	B1801.7
1.8	46	10	22	4	2	B1801.8
1.9	46	10	22	4	2	B1801.9
2.0	49	11	24	4	2	B1802.0
2.1	49	11	24	4	2	B1802.1
2.2	53	12	26	4	3	B1802.2
2.3	53	12	26	4	3	B1802.3
2.4	57	14	28	4	3	B1802.4
2.5	57	14	28	4	3	B1802.5
2.6	57	14	28	4	3	B1802.6
2.7	61	15	32	6	3	B1802.7
2.8	61	15	32	6	3	B1802.8
2.9	61	15	32	6	3	B1802.9
3.0	61	15	32	6	3	B1803.0
3.1	65	16	35	6	4	B1803.1
3.2	65	16	35	6	4	B1803.2
3.3	65	16	35	6	4	B1803.3
3.4	70	18	40	6	4	B1803.4
3.5	70	18	40	6	4	B1803.5
3.6	70	18	40	6	4	B1803.6
3.7	70	18	40	6	4	B1803.7
3.8	75	19	43	6	4	B1803.8
3.9	75	19	43	6	4	B1803.9
4.0	75	19	43	6	4	B1804.0
4.1	75	19	43	6	4	B1804.1
4.2	75	19	43	6	4	B1804.2
4.3	80	21	47	6	5	B1804.3
4.4	80	21	47	6	5	B1804.4
4.5	80	21	47	6	5	B1804.5
4.6	80	21	47	6	5	B1804.6
4.7	80	21	47	6	5	B1804.7
4.8	86	23	52	6	5	B1804.8
4.9	86	23	52	6	5	B1804.9
5.0	86	23	52	6	5	B1805.0
5.1	86	23	52	6	5	B1805.1
5.2	86	23	52	6	5	B1805.2
5.3	86	23	52	6	5	B1805.3
5.4	93	26	57	6	6	B1805.4

d_1 Ø mm	l_1 mm	l_2 mm	l_3 mm	z	d_2 Ø _{h₆} mm	B180
5.5	93	26	57	6	6	B1805.5
5.6	93	26	57	6	6	B1805.6
5.7	93	26	57	6	6	B1805.7
5.8	93	26	57	6	6	B1805.8
5.9	93	26	57	6	6	B1805.9
6.0	93	26	57	6	6	B1806.0
6.1	101	28	63	6	6	B1806.1
6.2	101	28	63	6	6	B1806.2
6.3	101	28	63	6	6	B1806.3
6.4	101	28	63	6	6	B1806.4
6.5	101	28	63	6	6	B1806.5
6.6	101	28	63	6	6	B1806.6
6.7	101	28	63	6	6	B1806.7
6.8	109	31	69	6	8	B1806.8
6.9	109	31	69	6	8	B1806.9
7.0	109	31	69	6	8	B1807.0
7.1	109	31	69	6	8	B1807.1
7.2	109	31	69	6	8	B1807.2
7.3	109	31	69	6	8	B1807.3
7.4	109	31	69	6	8	B1807.4
7.5	109	31	69	6	8	B1807.5
7.6	117	33	75	6	8	B1807.6
7.7	117	33	75	6	8	B1807.7
7.8	117	33	75	6	8	B1807.8
7.9	117	33	75	6	8	B1807.9
8.0	117	33	75	6	8	B1808.0
8.1	117	33	75	6	8	B1808.1
8.2	117	33	75	6	8	B1808.2
8.3	117	33	75	6	8	B1808.3
8.4	117	33	75	6	8	B1808.4
8.5	117	33	75	6	8	B1808.5
8.6	125	36	81	6	10	B1808.6
8.7	125	36	81	6	10	B1808.7
8.8	125	36	81	6	10	B1808.8
8.9	125	36	81	6	10	B1808.9
9.0	125	36	81	6	10	B1809.0
9.1	125	36	81	6	10	B1809.1
9.2	125	36	81	6	10	B1809.2
9.3	125	36	81	6	10	B1809.3
9.4	125	36	81	6	10	B1809.4
9.5	125	36	81	6	10	B1809.5
9.6	133	38	87	6	10	B1809.6
9.7	133	38	87	6	10	B1809.7
9.8	133	38	87	6	10	B1809.8
9.9	133	38	87	6	10	B1809.9
10.0	133	38	87	6	10	B18010.0
11.0	142	41	96	6	10	B18011.0
12.0	151	44	105	6	10	B18012.0
13.0	151	44	105	6	10	B18013.0
14.0	160	47	110	8	14	B18014.0
15.0	162	50	112	8	14	B18015.0
16.0	170	52	120	8	14	B18016.0
17.0	175	54	123	8	14	B18017.0
18.0	182	56	130	8	14	B18018.0
19.0	189	58	131	8	16	B18019.0
20.0	195	60	137	8	16	B18020.0

- B170**
- Alesatore centesimale a macchina
 - 1/100 Maschinen-Reibahle
 - 1/100 Machineruimer
 - Alésoir Machine au centième

B170	▪	1.1	1.2	1.3	1.4	2.1	4.2	5.1											
	•	1.5	1.6	2.2	2.3	3.1	3.2	3.3	3.4	4.1	4.3	5.2	5.3	6.1	6.2	6.3	6.4		

B170 HSS-E



DIN
212



B

Ø.95-5.5
0,+0.004
Ø5.51-12
0,+0.005



B170



0.98 - 12.00

d_1 Ø mm	l_1 mm	l_2 mm	l_3 mm	z	d_2 Ø _{h9} mm	B170
0.98	34	5.5	15	3	1.0	B170.98
0.99	34	5.5	15	3	1.0	B170.99
1.00	34	5.5	15	3	1.0	B1701.0
1.01	34	5.5	15	3	1.0	B1701.01
1.02	34	5.5	15	3	1.0	B1701.02
1.03	34	5.5	15	3	1.0	B1701.03
1.04	34	5.5	15	3	1.0	B1701.04
1.05	34	5.5	15	3	1.0	B1701.05
1.49	40	8.0	18	3	1.5	B1701.49
1.50	40	8.0	18	3	1.5	B1701.5
1.51	43	9.0	20	3	1.6	B1701.51
1.52	43	9.0	20	3	1.6	B1701.52
1.98	49	11.0	24	4	2.0	B1701.98
1.99	49	11.0	24	4	2.0	B1701.99
2.00	49	11.0	24	4	2.0	B1702.0
2.01	49	11.0	24	4	2.0	B1702.01
2.02	49	11.0	24	4	2.0	B1702.02
2.03	49	11.0	24	4	2.0	B1702.03
2.04	49	11.0	24	4	2.0	B1702.04
2.05	49	11.0	24	4	2.0	B1702.05
2.49	57	14.0	28	4	2.5	B1702.49
2.50	57	14.0	28	4	2.5	B1702.5
2.51	57	14.0	28	4	2.5	B1702.51
2.52	57	14.0	28	4	2.5	B1702.52
2.98	61	15.0	32	6	3.0	B1702.98
2.99	61	15.0	32	6	3.0	B1702.99
3.00	61	15.0	32	6	3.0	B1703.0
3.01	65	16.0	35	6	3.2	B1703.01
3.02	65	16.0	35	6	3.2	B1703.02
3.03	65	16.0	35	6	3.2	B1703.03
3.04	65	16.0	35	6	3.2	B1703.04
3.05	65	16.0	35	6	3.2	B1703.05
3.49	70	18.0	40	6	3.5	B1703.49
3.50	70	18.0	40	6	3.5	B1703.5
3.51	70	18.0	40	6	3.5	B1703.51
3.52	70	18.0	40	6	3.5	B1703.52
3.98	75	19.0	43	6	4.0	B1703.98
3.99	75	19.0	43	6	4.0	B1703.99
4.00	75	19.0	43	6	4.0	B1704.0
4.01	75	19.0	43	6	4.0	B1704.01

d_1 Ø mm	l_1 mm	l_2 mm	l_3 mm	z	d_2 Ø h_3 mm	B170
4.02	75	19.0	43	6	4.0	B1704.02
4.03	75	19.0	43	6	4.0	B1704.03
4.04	75	19.0	43	6	4.0	B1704.04
4.05	75	19.0	43	6	4.0	B1704.05
4.49	80	21.0	47	6	4.5	B1704.49
4.50	80	21.0	47	6	4.5	B1704.5
4.51	80	21.0	47	6	4.5	B1704.51
4.52	80	21.0	47	6	4.5	B1704.52
4.98	86	23.0	52	6	5.0	B1704.98
4.99	86	23.0	52	6	5.0	B1704.99
5.00	86	23.0	52	6	5.0	B1705.0
5.01	86	23.0	52	6	5.0	B1705.01
5.02	86	23.0	52	6	5.0	B1705.02
5.03	86	23.0	52	6	5.0	B1705.03
5.04	86	23.0	52	6	5.0	B1705.04
5.05	86	23.0	52	6	5.0	B1705.05
5.49	93	26.0	57	6	5.6	B1705.49
5.50	93	26.0	57	6	5.6	B1705.5
5.51	93	26.0	57	6	5.6	B1705.51
5.52	93	26.0	57	6	5.6	B1705.52
5.98	93	26.0	57	6	5.6	B1705.98
5.99	93	26.0	57	6	5.6	B1705.99
6.00	93	26.0	57	6	5.6	B1706.0
6.01	101	28.0	63	6	6.3	B1706.01
6.02	101	28.0	63	6	6.3	B1706.02
6.03	101	28.0	63	6	6.3	B1706.03
6.04	101	28.0	63	6	6.3	B1706.04
6.05	101	28.0	63	6	6.3	B1706.05
6.49	101	28.0	63	6	6.3	B1706.49
6.50	101	28.0	63	6	6.3	B1706.5
6.51	101	28.0	63	6	6.3	B1706.51
6.52	101	28.0	63	6	6.3	B1706.52
6.98	109	31.0	69	6	7.1	B1706.98
6.99	109	31.0	69	6	7.1	B1706.99
7.00	109	31.0	69	6	7.1	B1707.0
7.01	109	31.0	69	6	7.1	B1707.01
7.02	109	31.0	69	6	7.1	B1707.02
7.03	109	31.0	69	6	7.1	B1707.03
7.04	109	31.0	69	6	7.1	B1707.04
7.05	109	31.0	69	6	7.1	B1707.05
7.49	109	31.0	69	6	7.1	B1707.49
7.50	109	31.0	69	6	7.1	B1707.5
7.51	117	33.0	75	6	8.0	B1707.51
7.52	117	33.0	75	6	8.0	B1707.52
7.98	117	33.0	75	6	8.0	B1707.98
7.99	117	33.0	75	6	8.0	B1707.99
8.00	117	33.0	75	6	8.0	B1708.0
8.01	117	33.0	75	6	8.0	B1708.01
8.02	117	33.0	75	6	8.0	B1708.02
8.03	117	33.0	75	6	8.0	B1708.03
8.04	117	33.0	75	6	8.0	B1708.04
8.05	117	33.0	75	6	8.0	B1708.05
8.49	117	33.0	75	6	8.0	B1708.49
8.50	117	33.0	75	6	8.0	B1708.5
8.51	125	36.0	81	6	9.0	B1708.51
8.52	125	36.0	81	6	9.0	B1708.52
8.98	125	36.0	81	6	9.0	B1708.98
8.99	125	36.0	81	6	9.0	B1708.99
9.00	125	36.0	81	6	9.0	B1709.0
9.01	125	36.0	81	6	9.0	B1709.01
9.02	125	36.0	81	6	9.0	B1709.02
9.03	125	36.0	81	6	9.0	B1709.03
9.04	125	36.0	81	6	9.0	B1709.04
9.05	125	36.0	81	6	9.0	B1709.05
9.49	125	36.0	81	6	9.0	B1709.49
9.50	125	36.0	81	6	9.0	B1709.5
9.51	133	38.0	87	6	10.0	B1709.51
9.52	133	38.0	87	6	10.0	B1709.52
9.98	133	38.0	87	6	10.0	B1709.98
9.99	133	38.0	87	6	10.0	B1709.99

d_1 Ø mm	l_1 mm	l_2 mm	l_3 mm	z	d_2 Ø h_9 mm	B170
10.00	133	38.0	87	6	10.0	B17010.0
10.01	133	38.0	87	6	10.0	B17010.01
10.02	133	38.0	87	6	10.0	B17010.02
10.03	133	38.0	87	6	10.0	B17010.03
10.04	133	38.0	87	6	10.0	B17010.04
10.05	133	38.0	87	6	10.0	B17010.05
10.49	133	38.0	87	6	10.0	B17010.49
10.51	133	38.0	87	6	10.0	B17010.51
10.52	133	38.0	87	6	10.0	B17010.52
10.98	142	41.0	96	6	10.0	B17010.98
10.99	142	41.0	96	6	10.0	B17010.99
11.00	142	41.0	96	6	10.0	B17011.0
11.01	142	41.0	96	6	10.0	B17011.01
11.02	142	41.0	96	6	10.0	B17011.02
11.03	142	41.0	96	6	10.0	B17011.03
11.04	142	41.0	96	6	10.0	B17011.04
11.05	142	41.0	96	6	10.0	B17011.05
11.49	142	41.0	96	6	10.0	B17011.49
11.50	142	41.0	96	6	10.0	B17011.5
11.51	142	41.0	96	6	10.0	B17011.51
11.52	142	41.0	96	6	10.0	B17011.52
11.98	151	44.0	105	6	10.0	B17011.98
11.99	151	44.0	105	6	10.0	B17011.99
12.00	151	44.0	105	6	10.0	B17012.0

B157

- Alesatore a macchina ad elica sinistra 45°
- Maschinen-Schälreibahle mit 45° linksdrall
- Machine-schilruimer met 45° linkse spiraal
- Alésoir Machine Hélice 45° à gauche

B157	▪	1.1	1.2	1.3	1.4	2.1	2.2	2.3	4.1	4.2	4.3	5.1	5.2	5.3	6.1	7.1	7.2	7.3	7.4	8.1
	•	1.5	1.6	6.2	9.1															

B157 HSS-E E H7



d_1 Ø mm	l_1 mm	l_2 mm	l_3 mm	l_4 mm	z	d_2 Ø _{h9} mm	B157
2.0	49	11	3.5	24	3	2.0	B1572.0
3.0	61	15	4.0	32	3	3.0	B1573.0
4.0	75	19	4.0	43	3	4.0	B1574.0
5.0	86	23	4.5	52	3	5.0	B1575.0
6.0	93	26	6.0	57	3	5.6	B1576.0
7.0	109	31	7.0	69	3	7.1	B1577.0
8.0	117	33	9.0	75	3	8.0	B1578.0
9.0	125	36	9.5	81	3	9.0	B1579.0
10.0	133	38	10.0	87	3	10.0	B15710.0
11.0	142	41	10.5	96	3	10.0	B15711.0
12.0	151	44	11.0	105	3	10.0	B15712.0
13.0	151	44	11.5	105	3	10.0	B15713.0
14.0	160	47	12.0	110	3	12.5	B15714.0
15.0	162	50	12.5	112	3	12.5	B15715.0
16.0	170	52	13.0	120	3	12.5	B15716.0
17.0	175	54	13.5	123	3	14.0	B15717.0
18.0	182	56	14.0	130	3	14.0	B15718.0
19.0	189	58	14.5	131	3	16.0	B15719.0
20.0	195	60	15.0	137	3	16.0	B15720.0

B161

- Alesatore a macchina
- MK-Maschinenreibahle
- Machineruimer
- Alésoir machine conique pour trous de goupilles

B161	▪	1.1	1.2	1.3	1.4	2.1	4.1	5.1								
	•	1.5	1.6	2.2	2.3	3.1	3.2	3.3	3.4	4.2	4.3	5.2	5.3	6.1	6.2	6.3

B161 HSS-E



DIN
208



B

H7



B161



3.00 - 50.00

d_1 Ø mm	l_1 mm	l_2 mm	l_3 mm	z	MK	B161
3.0	113	15	47.5	6	1	B1613.0
4.0	124	19	58.5	6	1	B1614.0
5.0	133	23	67.5	6	1	B1615.0
6.0	138	26	72.5	6	1	B1616.0
7.0	150	31	84.5	6	1	B1617.0
8.0	156	33	90.5	6	1	B1618.0
9.0	162	36	96.5	6	1	B1619.0
10.0	168	38	102.5	6	1	B16110.0
11.0	175	41	109.5	6	1	B16111.0
12.0	182	44	116.5	6	1	B16112.0
13.0	182	44	116.5	6	1	B16113.0
14.0	189	47	123.5	8	1	B16114.0
15.0	204	50	124	8	2	B16115.0
16.0	210	52	130	8	2	B16116.0
17.0	214	54	134	8	2	B16117.0
18.0	219	56	139	8	2	B16118.0
19.0	223	58	143	8	2	B16119.0
20.0	228	60	148	8	2	B16120.0
21.0	232	62	152	8	2	B16121.0
22.0	237	64	157	8	2	B16122.0
23.0	241	66	161	8	2	B16123.0
24.0	268	68	169	8	3	B16124.0
25.0	268	68	169	8	3	B16125.0
26.0	273	70	174	8	3	B16126.0
27.0	277	71	178	10	3	B16127.0
28.0	277	71	178	10	3	B16128.0
29.0	281	73	182	10	3	B16129.0
30.0	281	73	182	10	3	B16130.0
31.0	285	75	186	10	3	B16131.0
32.0	317	77	193	10	4	B16132.0
33.0	317	77	193	10	4	B16133.0
34.0	321	78	197	10	4	B16134.0
35.0	321	78	197	10	4	B16135.0
36.0	325	79	201	10	4	B16136.0
38.0	329	81	205	10	4	B16138.0
40.0	329	81	205	10	4	B16140.0
42.0	333	82	209	12	4	B16142.0
44.0	336	83	212	12	4	B16144.0

d₁ ∅ mm	l₁ mm	l₂ mm	l₃ mm	z	MK	B161
45.0	336	83	212	12	4	B16145.0
46.0	340	84	216	12	4	B16146.0
47.0	340	84	216	12	4	B16147.0
48.0	344	86	220	12	4	B16148.0
50.0	344	86	220	12	4	B16150.0

- B101**
- Alesatore a macchina
 - MK-Maschinenreibahle
 - Machineruimer
 - Alésoir machine conique pour trous de goupilles

B101	▪	1.1	1.2	1.3	1.4	2.1	3.1	4.1	6.2								
	•	1.5	1.6	3.2	3.3	3.4	4.2	4.3	5.1	5.2	5.3	6.1	6.3	6.4	7.1	7.2	8.2

B101 HSS-E       

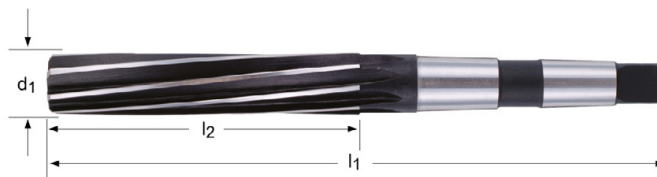

B101



3.00 - 2"

d_1 Ø Inch	d_1 Ø mm	l_1 mm	l_2 mm	z	MK	B101
1/8	3.00	112	33	4	1	B1013.0
	3.18	112	33	4	1	B1011/8
	3.50	115	35	6	1	B1013.5
	4.00	117	38	6	1	B1014.0
	4.50	120	41	6	1	B1014.5
3/16	4.76	124	44	6	1	B1013/16
	5.00	124	44	6	1	B1015.0
	5.50	127	47	6	1	B1015.5
	6.00	127	47	6	1	B1016.0
1/4	6.35	130	50	6	1	B1011/4
	6.50	130	50	6	1	B1016.5
	7.00	134	54	6	1	B1017.0
5/16	7.94	138	58	6	1	B1015/16
	8.00	138	58	6	1	B1018.0
	8.50	138	58	6	1	B1018.5
	9.00	142	62	6	1	B1019.0
	9.50	142	62	6	1	B1019.5
3/8	9.52	146	66	6	1	B1013/8
	10.00	146	66	6	1	B10110.0
	10.50	146	66	6	1	B10110.5
	11.00	151	71	6	1	B10111.0
7/16	11.11	151	71	6	1	B1017/16
	12.00	156	76	6	1	B10112.0
	12.50	156	76	6	1	B10112.5
1/2	12.70	156	76	6	1	B1011/2
	13.00	156	76	6	1	B10113.0
	13.50	161	81	6	1	B10113.5
	14.00	161	81	8	1	B10114.0
9/16	14.29	181	81	8	2	B1019/16
	14.50	181	81	8	2	B10114.5
	15.00	181	81	8	2	B10115.0
5/8	15.50	187	87	8	2	B10115.5
	15.88	187	87	8	2	B1015/8
	16.00	187	87	8	2	B10116.0
	16.50	187	87	8	2	B10116.5
	17.00	187	87	8	2	B10117.0
	18.00	193	93	8	2	B10118.0
	19.00	193	93	8	2	B10119.0
3/4	19.05	200	100	8	2	B1013/4
	20.00	200	100	8	2	B10120.0

d₁ Ø	d₁ Ø	l₁	l₂	z	MK	B101
Inch	mm	mm	mm			
13/16	20.64	200	100	8	2	B10113/16
	21.00	200	100	8	2	B10121.0
	22.00	207	107	8	2	B10122.0
7/8	22.22	207	107	8	2	B1017/8
	23.00	207	107	8	2	B10123.0
	24.00	242	115	8	3	B10124.0
1"	25.00	242	115	10	3	B10125.0
	25.40	242	115	10	3	B1011
	26.00	242	115	10	3	B10126.0
	27.00	251	124	10	3	B10127.0
1.1/8	28.00	251	124	10	3	B10128.0
	28.58	251	124	10	3	B1011.1/8
	29.00	251	124	10	3	B10129.0
	30.00	251	124	10	3	B10130.0
1.1/4	31.00	260	133	10	3	B10131.0
	31.75	260	133	10	3	B1011.1/4
	32.00	293	133	10	4	B10132.0
	34.00	302	142	10	4	B10134.0
1.3/8	34.93	302	142	10	4	B1011.3/8
	35.00	302	142	10	4	B10135.0
	36.00	302	142	10	4	B10136.0
	37.00	302	142	10	4	B10137.0
	38.00	312	152	10	4	B10138.0
1.1/2	38.10	312	152	10	4	B1011.1/2
	39.00	312	152	10	4	B10139.0
	40.00	312	152	10	4	B10140.0
	41.00	312	152	10	4	B10141.0
	42.00	312	152	10	4	B10142.0
	43.00	323	163	10	4	B10143.0
	44.00	323	163	10	4	B10144.0
1.3/4	44.45	323	163	10	4	B1011.3/4
	45.00	323	163	12	4	B10145.0
	46.00	323	163	12	4	B10146.0
	47.00	323	163	12	4	B10147.0
	48.00	334	174	12	4	B10148.0
	50.00	334	174	12	4	B10150.0
	2"	50.80	334	174	12	4

B121

- Alesatori con codolo Morse
- MK Nietloch Reibahle
- Klinkgatuimer, morseconus
- Queue cone morse Alésoirs de chaudronnerie

Con conicità 1:10
für Kegelstifte 1:10
Coniciteit 1:10
Goupilles cônica 1:10

B121	▪	1.1	1.2	1.3	1.4	3.1	4.1
	•	1.5	1.6	3.2	3.3	3.4	8.2

B121

HSS



DIN
311



k11

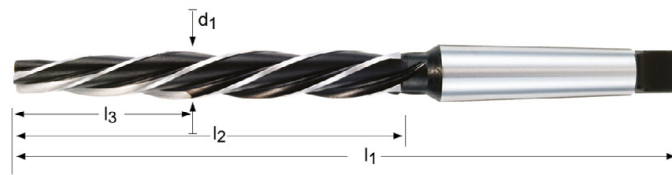

B121



10.00 - 30.00

d_1 Ø mm	l_1 mm	l_2 mm	l_3 mm	z	MK	B121
10.0	171	95	30	4	1	B12110.0
11.0	176	100	33	4	1	B12111.0
12.0	199	105	39	4	2	B12112.0
13.0	199	105	39	4	2	B12113.0
14.0	209	115	42	4	2	B12114.0
15.0	219	125	45	4	2	B12115.0
16.0	229	135	48	4	2	B12116.0
17.0	251	135	51	4	3	B12117.0
18.0	261	145	58	4	3	B12118.0
19.0	261	145	58	4	3	B12119.0
20.0	271	155	62	4	3	B12120.0
21.0	271	155	62	4	3	B12121.0
22.0	281	165	66	4	3	B12122.0
23.0	281	165	66	4	3	B12123.0
24.0	296	180	72	4	3	B12124.0
25.0	296	180	72	4	3	B12125.0
26.0	296	180	72	4	3	B12126.0
30.0	311	195	78	5	3	B12130.0

- B954**
- Alesatore a macchina per spine coniche ad elica sinistra 45°
 - Maschinen-Kegelreibahle mit 45° linksdrall
 - Machine-pengatruimer met 45° linkse spiraal
 - Alésoir Machine pour goupille conique Hélice à gauche à 45°

B954	▪	2.1	2.2	2.3	4.1	4.2	4.3	5.1	5.2	5.3	6.1	7.1	7.2	7.3	7.4	8.1
	•	1.1	1.2	1.3	1.4	1.5	1.6	6.2	9.1							

B954 HSS-E 1:50

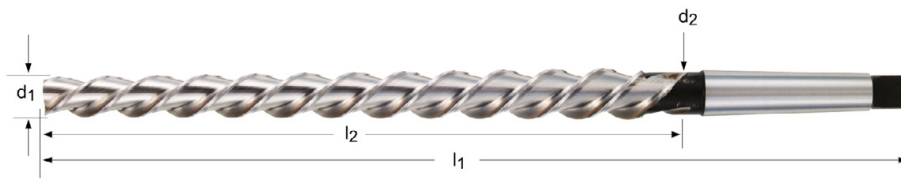

nom Ø	d_1 Ø mm	d_2 Ø mm	l_1 mm	l_2 mm	z	MK	B954
5.0	4.90	6.36	155	73	3	1	B9545.0
6.0	5.90	8.00	187	105	3	1	B9546.0
8.0	7.90	10.80	227	145	3	1	B9548.0
10.0	9.90	13.40	257	175	3	1	B95410.0
12.0	11.80	16.00	315	210	3	2	B95412.0
13.0	12.86	16.74	295	194	3	2	B95413.0
14.0	13.86	17.74	295	194	3	2	B95414.0
16.0	15.80	20.40	335	230	3	2	B95416.0
20.0	19.80	24.80	377	250	3	3	B95420.0
25.0	24.70	30.70	427	300	3	3	B95425.0
30.0	29.70	36.10	475	320	4	4	B95430.0

B955

- Alesatori a manicotto
- Maschinen-Aufsteck-Reibahle
- Opsteekruimer
- Alésoir creux machine

d2=Diametro nominale d1 del B956
d2=Nom. Durchmesser d1 von B956
d2=Nom. diameter d1 van B956
d2=Diamètre nominal d1 du B956

B955	▪	1.1	1.2	1.3	1.4	2.1	4.1	5.1								
	•	1.5	1.6	2.2	2.3	3.1	4.2	4.3	5.2	5.3	6.1	6.2	7.1	7.2	7.3	7.4

B955 HSS-E        

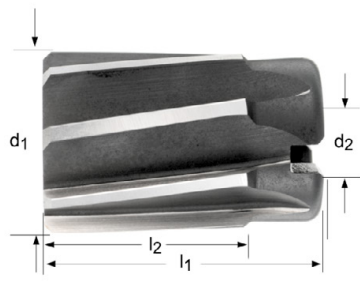

B955



25.00 - 80.00

d_1 Ø mm	l_1 mm	l_2 mm	z	d_2 Ø mm	B955
25.0	45	32	8	13	B95525.0
26.0	45	32	8	13	B95526.0
27.0	45	32	8	13	B95527.0
28.0	45	32	8	13	B95528.0
29.0	45	32	8	13	B95529.0
30.0	45	32	8	13	B95530.0
31.0	50	36	10	16	B95531.0
32.0	50	36	10	16	B95532.0
34.0	50	36	10	16	B95534.0
35.0	50	36	10	16	B95535.0
36.0	56	40	10	19	B95536.0
37.0	56	40	10	19	B95537.0
38.0	56	40	10	19	B95538.0
40.0	56	40	10	19	B95540.0
42.0	56	40	10	19	B95542.0
44.0	63	45	12	22	B95544.0
45.0	63	45	12	22	B95545.0
48.0	63	45	12	22	B95548.0
50.0	63	45	12	22	B95550.0
52.0	71	50	12	27	B95552.0
55.0	71	50	12	27	B95555.0
58.0	71	50	12	27	B95558.0
60.0	71	50	12	27	B95560.0
65.0	80	56	14	32	B95565.0
70.0	80	56	14	32	B95570.0
75.0	90	63	14	40	B95575.0
80.0	90	63	14	40	B95580.0

- B956**
- Codolo Conico Morse Mandrino per utensili a manicotto
 - MK-Halter für Aufsteck-Reibahle
 - Houder met morseconus voor opsteekruimer
 - Queue cône morse Porte-alésoirs creux

B956 HSS-E

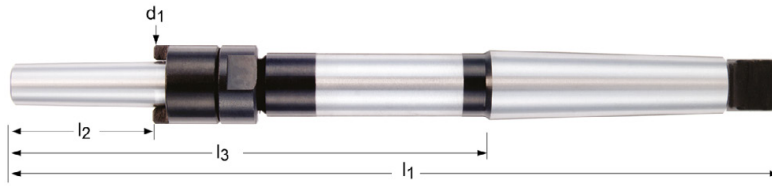

d_1 Ø mm	l_1 mm	l_2 mm	l_3 mm	MK	B956
13.0	250	45	151	3	B95613.0
16.0	261	50	162	3	B95616.0
19.0	298	56	174	4	B95619.0
22.0	312	63	188	4	B95622.0
27.0	359	71	203	5	B95627.0
32.0	376	80	220	5	B95632.0
40.0	396	90	240	5	B95640.0

B957

- Ricambi per mandrino utensili a manicotto (B956)
- Ersatzteile für MK Aufsteckhalter B956
- Doorn voor opsteekuimer- onderdelen
- Accessoires pour porte-alésoirs creux machine (B956)



DRIVER



NUT



WASHER



Nr.	d	B957
3	13.00	B957N3DRIVER
3		B957N3NUT
3		B957N3WASHER
4	16.00	B957N4DRIVER
4		B957N4NUT
4		B957N4WASHER
5	19.00	B957N5DRIVER
5		B957N5NUT
5		B957N5WASHER
6	22.00	B957N6DRIVER
6		B957N6NUT
6		B957N6WASHER
7	27.00	B957N7DRIVER
7		B957N7NUT
7		B957N7WASHER
8	32.00	B957N8DRIVER
8		B957N8NUT
8		B957N8WASHER
9	40.00	B957N9DRIVER
9		B957N9NUT
9		B957N9WASHER

G400

- Svasatore con codolo per mandrini ad alta precisione - 90°
- Kegelsenker für Hochgenauigkeitsfutter - 90°
- Verzinkboor voor Precisie-spanhouder - 90°
- Fraises à ébavurer et à chanfreiner pour mandrins haute précision - 90°

G400	▪	1.1	1.2	1.3	1.4	1.5	4.1	4.2	4.3	5.1	5.2	5.3	6.1	6.2	6.3
	•	1.6	2.1	2.2	2.3	3.1	3.2	3.3	3.4	6.4	7.1	7.2	7.3	7.4	8.1

G400

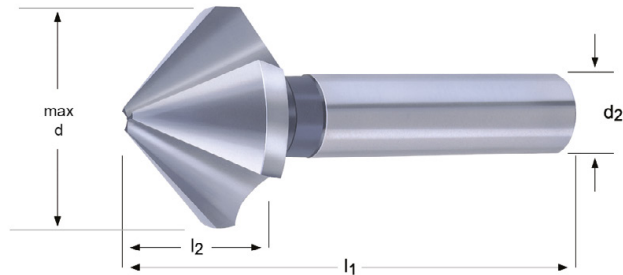

max d mm	min d mm	l ₂ mm	l ₁ mm	d ₂ Øh ₆ mm	z	G400
6.3	1.5	5.0	45	5	3	G4006.3
8.3	2.0	6.0	50	6	3	G4008.3
10.4	2.5	7.1	50	6	3	G40010.4
12.4	2.8	8.0	56	8	3	G40012.4
16.5	3.2	10.0	60	10	3	G40016.5
20.5	3.5	12.5	63	10	3	G40020.5
25.0	3.8	15.0	67	10	3	G40025.0
31.0	4.2	18.0	71	12	3	G40031.0

G135 • Svasatore - 60°
• Kegelsenker - 60°

G335 • Verzinkboor - 60°
• Fraises à ébavurer et à chanfreiner - 60°

G135	▪	1.1	1.2	1.3	1.4	1.5	4.1	4.2	4.3	5.1	5.2	5.3	6.1	6.2	6.3
	•	1.6	2.1	2.2	2.3	3.1	3.2	3.3	3.4	6.4	7.1	7.2	7.3	7.4	8.1
G335	▪	1.1	1.2	1.3	3.1	3.2	3.3	3.4	7.1	7.2	7.3	7.4			
	•	1.4	1.5	1.6	4.1	4.2	4.3	5.1	5.2	5.3	6.1	6.2	6.3	6.4	8.1

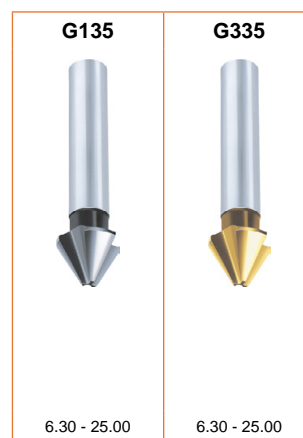
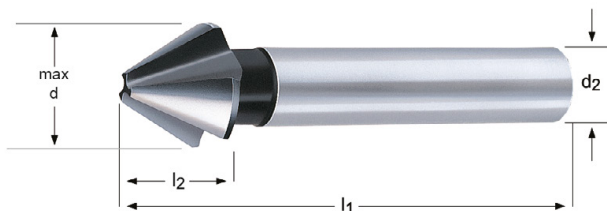

max d mm	min d mm	l ₂ mm	l ₁ mm	d ₂ Øh ₉ mm	z	G135	G335
6.3	1.6	6.8	45	5	3	G1356.3	G3356.3
8.0	2.0	8.5	50	6	3	G1358.0	G3358.0
10.0	2.5	7.6	50	6	3	G13510.0	G33510.0
12.5	3.2	11.7	56	8	3	G13512.5	G33512.5
16.0	4.0	14.5	63	10	3	G13516.0	G33516.0
20.0	5.0	17.5	67	10	3	G13520.0	G33520.0
25.0	6.3	20.5	71	10	3	G13525.0	G33525.0

- G137**
- Svasatore con codolo Morse - 60°
 - MK Kegelsenker - 60°
 - Verzinkboor met MC - 60°
 - Queue cône morse fraises à ébavurer et à chanfreiner - 60°

G137	▪	1.1	1.2	1.3	1.4	1.5	4.1	4.2	4.3	5.1	5.2	5.3	6.1	6.2	6.3
	•	1.6	2.1	2.2	2.3	3.1	3.2	3.3	3.4	6.4	7.1	7.2	7.3	7.4	8.1

G137 HSS

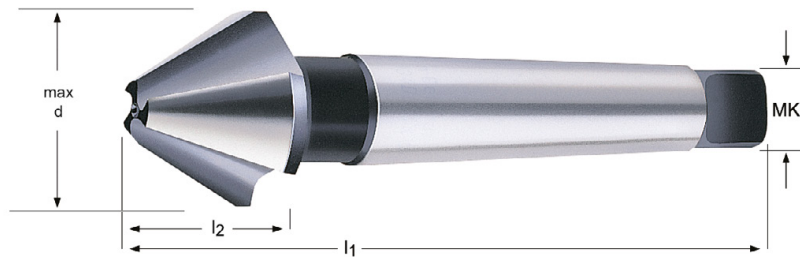

max d mm	min d mm	l ₂ mm	l ₁ mm	MK	z	G137
16.0	4.0	14.5	90	1	3	G13716.0
20.0	5.0	17.5	106	2	3	G13720.0
25.0	6.3	20.0	112	2	3	G13725.0
31.5	10.0	23.0	118	2	3	G13731.5
40.0	12.5	28.5	150	3	3	G13740.0
50.0	16.0	36.0	160	3	3	G13750.0
63.0	20.0	43.0	190	4	3	G13763.0
80.0	25.0	54.0	200	4	3	G13780.0

- G154**
- Svasatore - 82°
 - Kegelsenker - 82°
 - Verzinkboor - 82°
 - Fraises à ébavurer et à chanfreiner - 82°

G154	▪	1.1	1.2	1.3	1.4	1.5	4.1	4.2	4.3	5.1	5.2	5.3	6.1	6.2	6.3
	•	1.6	2.1	2.2	2.3	3.1	3.2	3.3	3.4	6.4	7.1	7.2	7.3	7.4	8.1

G154

HSS



DIN
335C





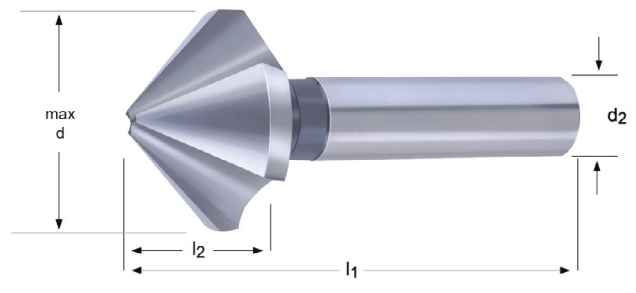



max d mm	min d mm	l ₂ mm	l ₁ mm	d ₂ Øh ₉ mm	z	G154
6.3	1.5	5.5	45	5	3	G1546.3
8.3	2.0	6.5	50	6	3	G1548.3
10.4	2.5	7.6	50	6	3	G15410.4
12.4	2.8	8.5	56	8	3	G15412.4
16.5	3.2	10.5	60	10	3	G15416.5
20.5	3.5	13.0	63	10	3	G15420.5
25.0	3.8	15.5	67	10	3	G15425.0

- G129**
- Svasatore monotagliante - 90°
 - Kegelsenker 90°, spitz auslaufend
 - Verzinkboor - 90°
 - Fraises à ébavurer et à chanfreiner - 90°

G129	▪	1.1	1.2	1.3	1.4	4.1	4.2	5.1	5.2	6.1	6.2	6.3	7.1	7.2	
	•	1.1	1.6	2.1	2.2	3.1	3.2	3.3	3.4	4.3	5.3	6.4	7.3	7.4	8.1

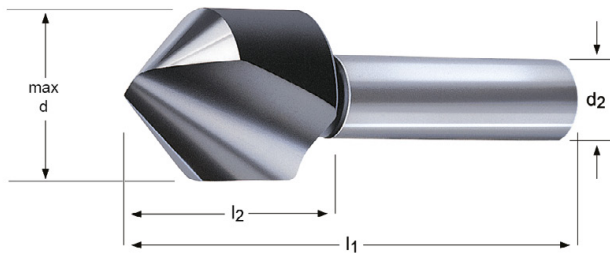
G129 HSS



max d mm	l ₂ mm	l ₁ mm	d ₂ ∅h ₉ mm	z	G129
6.0	0.0	45	6	1	G1296.0
8.0	0.0	50	8	1	G1298.0
10.0	17.0	49	8	1	G12910.0
12.5	17.0	49	8	1	G12912.5
16.0	20.0	56	10	1	G12916.0
20.0	24.0	60	10	1	G12920.0
25.0	25.0	75	12	1	G12925.0
31.5	29.0	80	12	1	G12931.5

- G149**
- Svasatore monotagliante - 90°
 - Kegelsenker 90°, spitz auslaufend
 - Verzinkboor - 90°
 - Fraises à ébavurer et à chanfreiner - 90°

G149	▪	1.1	1.2	1.3	1.4	4.1	4.2	5.1	5.2	6.1	6.2	6.3	7.1	7.2	
	•	1.5	1.6	2.1	2.2	3.1	3.2	3.3	3.4	4.3	5.3	6.4	7.3	7.4	8.1

G149 HSS-E      

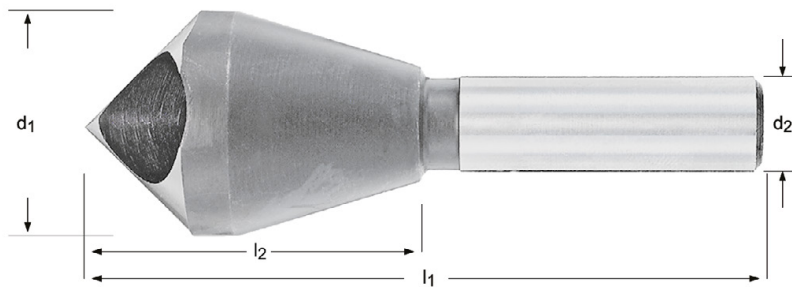

max d mm	min d mm	l ₂ mm	l ₁ mm	d ₂ Ø mm	d ₁ Ø mm	z	G149
5	2	19.0	45	6	10	1	G1495
10	5	23.0	48	8	14	1	G14910
15	10	34.0	65	10	21	1	G14915
20	15	43.0	84	12	28	1	G14920
25	20	48.0	102	15	35	1	G14925
30	25	61.0	115	15	44	1	G14930
35	30	65.0	127	15	48	1	G14935
40	35	66.0	136	15	53	1	G14940
50	40	85.0	166	20	60	1	G14950

- G136** • Svasatore monotagliante - 90°
 • Kegelsenker 90°, spitz auslaufend
- G560** • Verzinkboor - 90°
 • Fraises à ébavurer et à chanfreiner - 90°

- G106** • Svasatore 90° codolo con piano di bloccaggio
 • Kegelsenker mit Polygonschaft -90°
- G506** • Verzinkboor met drie spanvlakken - 90°
 • Fraises à ébavurer et à chanfreiner avec queue cylindrique 3 plats - 90

G136	▪	1.1	1.2	1.3	1.4	4.1	4.2	5.1	5.2	6.1	6.2	6.3	7.1	7.2	8.1	
	•	1.5	1.6	2.1	2.2	2.3	3.1	3.2	3.3	3.4	4.3	5.3	6.4	7.3	7.4	8.2
G560	▪	1.1	1.2	1.3	1.4	1.5	2.1	3.1	3.2	3.3	3.4	5.1	5.2	5.3	7.3	7.4
	•	1.6	2.2	2.3	4.1	4.2	4.3	6.1	6.2	6.3	6.4	7.1	7.2	8.1	8.2	
G106	▪	1.1	1.2	1.3	1.4	1.5	4.1	4.2	4.3	5.1	5.2	5.3	6.1	6.2	6.3	
	•	1.6	2.1	2.2	2.3	3.1	3.2	3.3	3.4	6.4	7.1	7.2	7.3	7.4	8.1	8.2
G506	▪	1.1	1.2	1.3	3.1	3.2	3.3	3.4	7.1	7.2	7.3	7.4				
	•	1.4	1.5	1.6	4.1	4.2	4.3	5.1	5.2	5.3	6.1	6.2	6.3	6.4	8.1	8.2

G136	HSS		DIN 335C				90°		G236 194
G560	HSS	TiAlN	DIN 335C				90°		G236 194
G106	HSS		DIN 335C				90°		G236 194
G506	HSS	TiAlN	DIN 335C				90°		G236 194

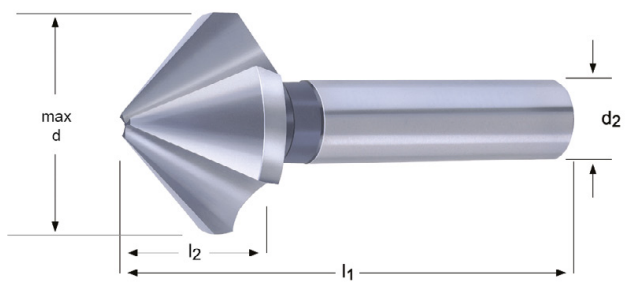

max d mm	min d mm	l ₂ mm	l ₁ mm	d ₂ Øh ₉ mm	z	G136	G560	G106	G506
4.3	1.3	4.0	40	4	3	G1364.3			
5.0	1.5	4.5	40	4	3	G1365.0			
5.3	1.5	4.5	40	4	3	G1365.3			
5.8	1.5	5.0	45	5	3	G1365.8			
6.0	1.5	5.0	45	5	3	G1366.0			
6.3	1.5	5.5	45	5	3	G1366.3	G5606.3		
6.3	1.5	5.6	45	5	3			G1066.3	G5066.3
7.0	1.8	5.5	50	6	3	G1367.0			
7.3	1.8	6.1	50	6	3	G1367.3			
8.0	2.0	6.1	50	6	3	G1368.0	G5608.0		
8.3	2.0	6.5	50	6	3	G1368.3	G5608.3		

max d mm	min d mm	l ₂ mm	l ₁ mm	d ₂ Øh ₃ mm	z	G136	G560	G106	G506
8.3	2.0	6.9	50	6	3			G1068.3	G5068.3
9.4	2.2	7.2	50	6	3	G1369.4			
10.0	2.5	7.6	50	6	3	G13610.0	G56010.0		
10.4	2.5	7.6	50	6	3	G13610.4	G56010.4		
10.4	2.5	7.8	50	6	3			G10610.4	G50610.4
11.5	2.8	8.0	56	8	3	G13611.5			
12.4	2.8	8.5	56	8	3	G13612.4	G56012.4		
12.4	2.8	8.6	56	8	3			G10612.4	G50612.4
13.4	2.9	9.0	56	8	3	G13613.4			
15.0	3.2	9.5	60	10	3	G13615.0			
16.5	3.2	10.5	60	10	3	G13616.5	G56016.5		
16.5	3.2	11.1	60	10	3			G10616.5	G50616.5
19.0	3.5	11.7	63	10	3	G13619.0			
20.5	3.5	13.0	63	10	3	G13620.5	G56020.5		
20.5	3.5	12.9	63	10	3			G10620.5	G50620.5
23.0	3.8	13.7	67	10	3	G13623.0			
25.0	3.8	15.5	67	10	3	G13625.0	G56025.0		
25.0	3.8	15.7	67	10	3			G10625.0	G50625.0
26.0	3.8	15.5	67	10	3	G13626.0			
28.0	4.0	16.5	71	12	3	G13628.0			
30.0	4.2	18.5	71	12	3	G13630.0			
31.0	4.2	18.5	71	12	3	G13631.0	G56031.0	G10631.0	G50631.0
34.0	4.5	19.0	103	16	3			G10634.0	G50634.0
37.0	4.5	21.2	118	16	3			G10637.0	G50637.0
40.0	4.5	20.0	118	16	3			G10640.0	G50640.0
50.0	5.0	23.6	126	16	3			G10650.0	G50650.0

- G142**
- Svasatore con spoglia radiale maggiorata - 90°
 - Kegelsenker 90°, radial hinterschleifen
 - Verzinkboor, radiaal achtergeschlepen - 90°
 - Fraises à ébavurer et à chanfreiner avec dépouille accentuée - 90°

- G570**
- Svasatore monotagliante - 90°
 - Kegelsenker 90°, spitz auslaufend
 - Verzinkboor - 90°
 - Fraises à ébavurer et à chanfreiner - 90°

G142	▪	1.1	1.2	2.1	2.2	2.3	4.1	5.1	6.1	6.2	7.1	7.2	8.1	8.2						
	•	1.3	1.4	4.2	5.2	6.3	7.3	7.4												
G570	▪	1.4	1.5	2.1	2.2	2.3														
	•	1.1	1.2	1.3	1.6	2.4	3.1	3.2	3.3	3.4	5.2	5.3	6.1	6.2	6.3	6.4	7.1	7.2	7.3	7.4

G142 HSS

G570 HSS-E

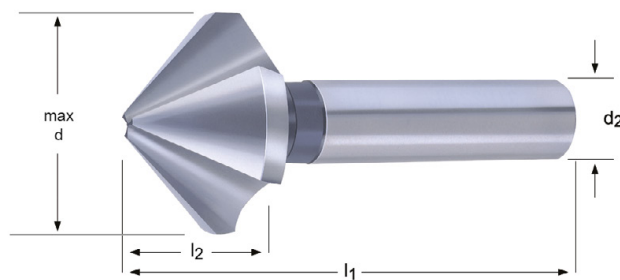

max d mm	min d mm	l ₂ mm	l ₁ mm	d ₂ Øh ₉ mm	z	G142	G570
4.8	1.3	4.5	40	4	3	G1424.8	
5.0	1.5	4.5	40	4	3	G1425.0	
6.0	1.5	5.0	45	5	3	G1426.0	
6.3	1.5	5.5	45	5	3	G1426.3	
6.3	1.5	6.5	45	5	3		G5706.3
7.0	1.8	5.5	50	6	3	G1427.0	
7.3	1.8	6.1	50	6	3	G1427.3	
8.0	2.0	6.1	50	6	3	G1428.0	
8.3	2.0	6.5	50	6	3	G1428.3	
8.3	2.0	8.2	50	6	3		G5708.3
10.0	2.5	7.6	50	6	3	G14210.0	
10.4	2.5	7.6	50	6	3	G14210.4	
10.4	2.5	9.7	50	6	3		G57010.4
11.5	2.8	8.0	56	8	3	G14211.5	
12.4	2.8	8.5	56	8	3	G14212.4	
12.4	2.8	10.6	56	8	3		G57012.4
15.0	3.2	9.5	60	10	3	G14215.0	
16.5	3.2	10.5	60	10	3	G14216.5	
16.5	3.2	13.9	60	10	3		G57016.5
19.0	3.5	11.7	63	10	3	G14219.0	
20.5	3.5	13.0	63	10	3	G14220.5	
20.5	3.5	17.1	63	10	3		G57020.5
23.0	3.8	13.7	67	10	3	G14223.0	
25.0	3.8	15.5	67	10	3	G14225.0	
25.0	3.8	21.4	67	10	3		G57025.0
31.0	4.2	18.5	71	12	3	G14231.0	
31.0	4.2	24.4	71	12	3		G57031.0

- G107**
- Svasatore 90° con codolo esagonale
 - Kegelsenker mit Sechskantschaft -90°
 - Verzinkboor met zeskant schacht - 90
 - Fraises à ébavurer et à chanfreiner avec queue hexagonale - 90

G107	▪	1.1	1.2	1.3	1.4	1.5	4.1	4.2	4.3	5.1	5.2	5.3	6.1	6.2	6.3
	•	1.6	2.1	2.2	2.3	3.1	3.2	3.3	3.4	6.4	7.1	7.2	7.3	7.4	8.1

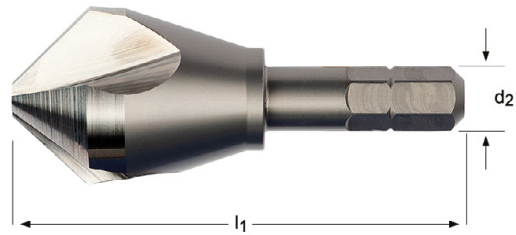

max d mm	min d mm	l ₁ mm	d ₂ Ø A/F mm	DIN 74	z	G107
6.3	1.5	50	1/4"	M2-M3	3	G1076.3
8.3	2.0	50	1/4"	M4	3	G1078.3
10.4	2.5	50	1/4"	M5	3	G10710.4
12.4	2.8	50	1/4"	M6	3	G10712.4
16.5	3.2	50	1/4"	M8	3	G10716.5
20.5	3.5	50	1/4"	M10	3	G10720.5

- G600**
- Svasatore, extra lungo - 90°
 - Kegelsenker, extra lang - 90°
 - Verzinkboor, extra lang - 90°
 - Fraises à ébavurer et à chanfreiner, Extra Longue - 90°

G600	▪	1.1	1.2	1.3	1.4	1.5										
		•	1.6	2.1	2.2	2.3	3.1	3.2	3.3	6.1	6.2	6.3	6.4	7.1	7.2	7.3

G600

HSS

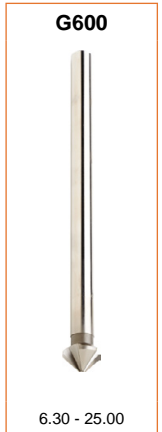

max d mm	min d mm	l ₂ mm	l ₁ mm	d ₂ Øh ₉ mm	z	G600
6.3	1.3	5.6	154	5	3	G6006.3
8.3	1.8	6.9	155	6	3	G6008.3
10.4	2.2	7.8	157	6	3	G60010.4
12.4	2.5	8.6	158	8	3	G60012.4
15.0	2.8	10.3	159	10	3	G60015.0
16.5	2.8	11.1	161	10	3	G60016.5
20.5	3.0	12.9	164	10	3	G60020.5
25.0	3.2	15.7	168	10	3	G60025.0

- G132**
- Svasatore monotagliante - 90°
 - Kegelsenker 90°, Krauskopfsenker
 - Verzinkboor - 90°
 - Fraises à ébavurer et à chanfreiner - 90°

G132	▪	1.5	1.6	3.4	4.2	4.3	5.2	5.3	6.4
	•	1.3	1.4	2.3	8.3				

G132

HSS



DIN
335A



90°

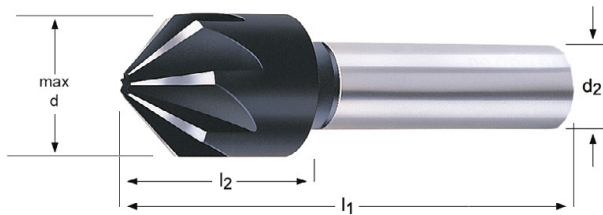

G132



8.00 - 20.00

max d mm	min d mm	l ₂ mm	l ₁ mm	d ₂ Øh ₉ mm	z	G132
8.0	-	0.0	48	8	5	G1328.0
12.5	2.0	15.5	48	8	5	G13212.5
16.0	3.2	19.5	56	10	7	G13216.0
20.0	5.0	23.0	60	10	7	G13220.0

G138 • Svasatore codolo Morse - 90°
• MK Kegelsenker - 90°

G338 • Verzinkboor met morseconus - 90°
• Queue cône morse fraises à ébavurer et à chanfreiner - 90°

G138	▪	1.1	1.2	1.3	1.4	1.5	4.1	4.2	4.3	5.1	5.2	5.3	6.1	6.2	6.3
	•	1.6	2.1	2.2	2.3	3.1	3.2	3.3	3.4	6.4	7.1	7.2	7.3	7.4	8.1
G338	▪	1.1	1.2	1.3	1.4	1.5	3.1	3.2	3.3	3.4	7.1	7.2	7.3	7.4	
	•	1.6	4.1	4.2	4.3	5.1	5.2	5.3	6.1	6.2	6.3	6.4	8.1	8.2	

G138 HSS

G338 HSS

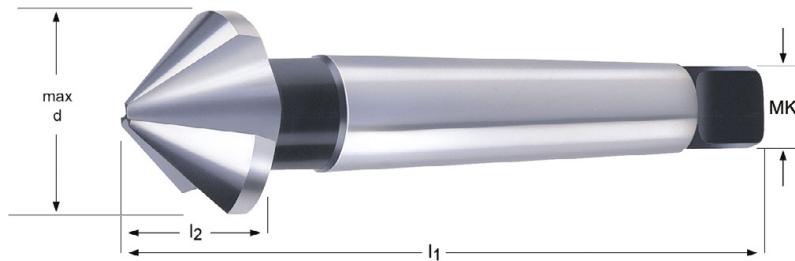

max d mm	min d mm	l ₂ mm	l ₁ mm	MK	z	G138	G338
25.0	3.8	15.5	106	2	3	G13825.0	G33825.0
30.0	4.2	18.5	112	2	3	G13830.0	
31.0	4.2	20.0	112	2	3	G13831.0	G33831.0
34.0	4.5	19.5	118	2	3	G13834.0	
37.0	4.8	21.7	118	2	3	G13837.0	G33837.0
40.0	10.0	20.5	140	3	3	G13840.0	G33840.0
50.0	14.0	24.1	150	3	3	G13850.0	G33850.0
63.0	16.0	28.5	180	4	3	G13863.0	G33863.0
80.0	22.0	36.0	190	4	3	G13880.0	

- G171**
- Svasatore - 100°
 - Kegelsenker - 100°
 - Verzinkboor - 100°
 - Fraises à ébavurer et à chanfreiner - 100°

G171	▪	1.1	1.2	1.3	3.1	3.2	3.3	3.4	7.1	7.2	7.3	7.4								
	•	1.4	1.5	1.6	4.1	4.2	4.3	5.1	5.2	5.3	6.1	6.2	6.3	6.4	8.1	8.2				

G171

HSS

TAIN

DIN
335C

100°

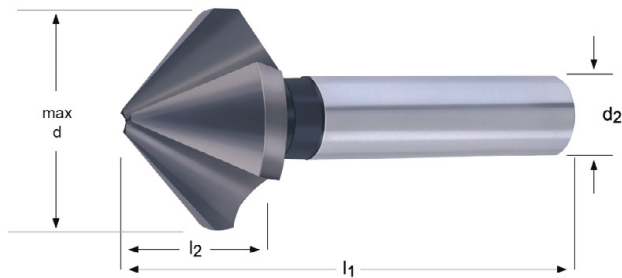

max d mm	min d mm	l ₂ mm	l ₁ mm	d ₂ Øh ₉ mm	z	G171
6.3	1.5	4.5	44	5	3	G1716.3
8.3	2.0	5.5	49	6	3	G1718.3
10.4	2.5	6.6	49	6	3	G17110.4
12.4	2.8	7.0	53	8	3	G17112.4
16.5	3.2	9.0	56	10	3	G17116.5
20.5	3.5	11.0	61	10	3	G17120.5
25.0	3.8	13.5	65	10	3	G17125.0

G314

- Punte coniche
- Mehrstufensenker
- Getrapte plaatboor
- Forets multi-diamètres

G314	▪	1.1	1.2	1.3	1.4	4.1	4.2	4.3	5.1	5.2	5.3	6.1	6.2	6.3	7.1	7.2	8.1	8.2	
	•	1.5	1.6	2.1	2.2	2.3	3.1	3.2	3.3	3.4	6.4	7.3	7.4						

G314 HSS 20°

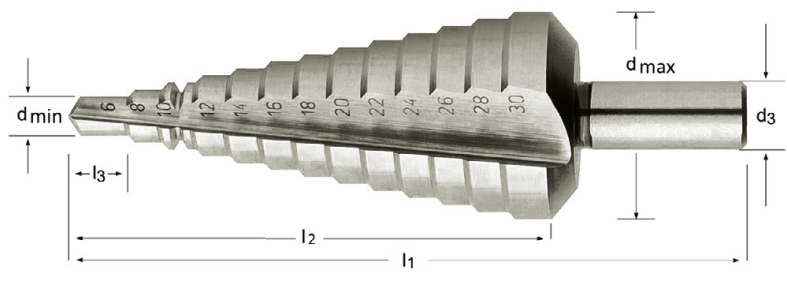

Nr.	d min-max mm	l ₃ mm	l ₂ mm	l ₁ mm	d ₃ ∅ mm	G314
412	4.0 mm ÷ 12.0 mm x 1.0 mm	5.0	61	80	6.0	G314412
1220	12.0 mm ÷ 20.0 mm x 1.0 mm	4.0	55	76	9.0	G3141220
2030	20.0 mm ÷ 30.0 mm x 1.0 mm	4.0	67	88	12.0	G3142030
3040	30.0 mm ÷ 40.0 mm x 1.0 mm	4.0	74	98	13.0	G3143040
420	4.0 mm ÷ 20.0 mm x 2.0 mm	4.0	48	76	8.0	G314420
630	6.0 mm ÷ 30.0 mm x 2.0 mm	4.0	73	98	10.0	G314630
M	9.0 mm ÷ 36.0 mm x 3.0 mm	3.0	57	86	12.0	G314M

- G125**
- Allargatori - 180°
 - Flachsenker - 180°
 - Kopverzinker - 180°
 - Fraises pour logement de tête de vis - 180°

G125	▪	1.1	1.2	1.3	2.1	3.1	3.2	7.1	7.2	8.1									
	•	1.4	1.5	1.6	2.2	3.3	3.4	4.1	4.2	4.3	5.1	5.2	5.3	6.1	6.2	6.3	7.3	7.4	8.2

G125 HSS      

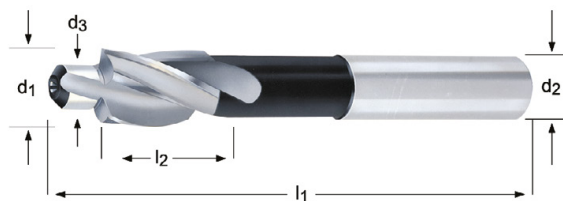

G125



6.50 - 20.00

d_1 $\varnothing z_3$ mm	d_3 $\varnothing e_8$ mm	M	l_1 mm	l_2 mm	d_2 $\varnothing h_9$ mm	z	G125
6.5	2.5	M 3 t	71	14	5.0	3	G1256.5X2.5 ¹⁾
6.5	3.2	M 3 f	71	14	5.0	3	G1256.5X3.2 ²⁾
6.5	3.4	M 3 m	71	14	5.0	3	G1256.5X3.4 ³⁾
8.0	3.3	M 4 t	71	14	5.0	3	G1258.0X3.3 ¹⁾
8.0	4.3	M 4 f	71	14	5.0	3	G1258.0X4.3 ²⁾
8.0	4.5	M 4 m	71	14	5.0	3	G1258.0X4.5 ³⁾
10.0	4.2	M 5 t	80	18	8.0	3	G12510.0X4.2 ¹⁾
10.0	5.3	M 5 f	80	18	8.0	3	G12510.0X5.3 ²⁾
10.0	5.5	M 5 m	80	18	8.0	3	G12510.0X5.5 ³⁾
11.0	5.0	M 6 t	80	18	8.0	3	G12511.0X5.0 ¹⁾
11.0	6.4	M 6 f	80	18	8.0	3	G12511.0X6.4 ²⁾
11.0	6.6	M 6 m	80	18	8.0	3	G12511.0X6.6 ³⁾
15.0	6.8	M 8 t	100	22	12.5	3	G12515.0X6.8 ¹⁾
15.0	8.4	M 8 f	100	22	12.5	3	G12515.0X8.4 ²⁾
15.0	9.0	M 8 m	100	22	12.5	3	G12515.0X9.0 ³⁾
18.0	8.5	M 10 t	100	22	12.5	3	G12518.0X8.5 ¹⁾
18.0	10.5	M 10 f	100	22	12.5	3	G12518.0X10.5 ²⁾
18.0	11.0	M 10 m	100	22	12.5	3	G12518.0X11.0 ³⁾
20.0	10.2	M 12 t	100	22	12.5	3	G12520.0X10.2 ¹⁾
20.0	13.0	M 12 f	100	22	12.5	3	G12520.0X13.0 ²⁾
20.0	13.5	M 12 m	100	22	12.5	3	G12520.0X13.5 ³⁾

¹⁾ t= per preforo di maschiatura / t = für Kernloch / t = voor kerngat / t = pour trou taraudé

²⁾ f= per foro passante / f= für Durchgangsloch fein / f= fijnpassing voor doorlopende gaten / f= pour trou de vis précis

³⁾ m= per foro passante, esecuzione media / m= für Durchgangsloch mittel / m= middelpassing voor doorlopende gaten / m = pour trou de vis moyen

G236

- Set svasatori
- Kegelsenker Satz
- Verzinkboren in sets
- Coffrets de fraises à ébavurer et à chanfreiner

A=Tipi in serie, B=No. punte in Set, C=diametri in Set

A=Typen in Satz, B=Anzahl, C=Durchmesser im Satz

A=Type, B=Aantal, C=Diameters

A=Types de coffrets, B=Nombre dans le coffret, C=Diamètres dans le coffret



Set

Nr.	A	B	C	G236
1	G136	6	6.30 mm, 8.30 mm, 10.40 mm, 12.40 mm, 16.50 mm, 20.50 mm	G2361
2	G136	4	6.30 mm, 10.40 mm, 16.50 mm, 20.50 mm	G2362
3	G560	6	6.30 mm, 8.30 mm, 10.40 mm, 12.40 mm, 16.50 mm, 20.50 mm	G2363
4	G106	6	6.30 mm, 8.30 mm, 10.40 mm, 12.40 mm, 16.50 mm, 20.50 mm	G2364
5	G506	6	6.30 mm, 8.30 mm, 10.40 mm, 12.40 mm, 16.50 mm, 20.50 mm	G2365

201 - 212



J200	205
J205	205
J210	206
J215	206
J220	207
J225	207
J235	208
J245	209
J260	211
J280	210

Forma Filetto	Gewindeform	Draadsoort	Forme de filet
Normativa	Standard	Norm	Standard
Profondità	Tiefe	Diepte	Profondeur
Materiale	Material	Materiaal	Matière
Angolo d'Elica	Drallwinkel	Spiraalhoek	Angle d'hélice
Senso di rotazione	Schneidrichtung	Snijrichting	Direction
Trattamento superficiale	Oberfläche	Oppervlaktebehandeling	Revêtement
Codolo	Schaft	Schacht	Queue
Lubrificazione	Kühlung	Koeling	Lubrification
■ Raccomandato	Sehr gut für die Anwendung	Uitstekend voor deze toepassing	Excellent pour les applications
● Accettabile	Gut für die Anwendung	Acceptabel voor deze toepassing	Acceptable pour les applications
Esempio 10 = Velocità periferica in m/min +/- 10%	Beispiel 10 = Schnittgeschwindigkeit (m/min) +/- 10 %	Voorbeeld 10 = snijnsnelheid in m/min +/-10%	Exemple 10 = Vitesse périphérique en mètres/ minute +/- 10%
Codice prodotto	Produktbezeichnung	Productcode	Codes
Gamma diametri	Durchmesserbereich	Diameterreeks	Gamme

AMG	Italiano	Deutsch	Nederlands	Français
1.1	Acciaio dolce magnetico	Magnetweicheisen	Automatenstaal, zachtstaal	Acier doux magnétique
1.2	Acciaio da costruzione e da cementazione	Baustahl, Einsatzstahl	Constructiestaal, inzetstaal	Acier de construction, Acier de cémentation
1.3	Acciaio al carbonio	Kohlenstoffstahl	Koolstofstaal	Acier au carbone ordinaire
1.4	Acciaio legato	Legierter Stahl	Gelegeerd staal	Acier allié
1.5	Acciaio legato / Acciaio bonificato e temprato	Legierter und vergüteter Stahl	Gelegeerd en veredeld staal	Acier allié/ Acier trempé et revenu
1.6	Acciaio legato / Acciaio bonificato e temprato	Legierter und vergüteter Stahl	Hooggelegeerd veredeld staal	Acier allié/ Acier trempé et revenu
1.7	Acciaio legato/temprato	Legierter gehärteter Stahl	Gelegeerd en gehard staal	Acier allié trempé
1.8	Acciaio legato/temprato	Legierter gehärteter Stahl	Gelegeerd en gehard staal	Acier allié trempé
2.1	Acciaio inossidabile/automatico	Rostfreier Stahl, geschwefelt	Roestvast automatenstaal	Acier inoxydable de décolletage
2.2	Austenitico	Austenitisch	Austenitisch	Austénitique
2.3	Ferritico+Austenitico, Martensitico	Ferritisch+Austenitisch, Martensitisch	Ferritisch+Austenitisch, Martensitisch	Ferritique + Austénitique, Martensitique
2.4	Acciai inossidabili con indurimento da precipitazione	Vergüteter rostfreier Stahl	Precipitatiehardend roestvast staal	Acier inoxydable Trempé
3.1	Ghisa con grafite lamellare	Grauguss	Gietijzer Lamellair	Graphite lamellaire
3.2	Ghisa con grafite lamellare	Vergüteter Grauguss	Gietijzer Lamellair	Graphite lamellaire
3.3	Ghisa malleabile con grafite sferoidale	Kugelgraphitguss, Temperguss	Nodulair gietijzer / Smeedbaar gietijzer	Graphite nodulaire/ Fonte malléable
3.4	Ghisa malleabile con grafite sferoidale	Kugelgraphitguss, Temperguss	Nodulair gietijzer / Smeedbaar gietijzer	Graphite nodulaire/ Fonte malléable
4.1	Titanio non legato	Reintitan	Titaan, ongelegeerd	Titane, non-allié
4.2	Leghe di titanio	Titan-Legierungen	Titaan, gelegeerd	Titane, allié
4.3	Leghe di titanio	Titan-Legierungen	Titaan, gelegeerd	Titane, allié
5.1	Nichel non legato	Reinnickel	Nikkel, ongelegeerd	Nickel, non-allié
5.2	Leghe di nichel	Nickel-Legierungen	Nikkel, gelegeerd	Nickel, allié
5.3	Leghe di nichel	Nickel-Legierungen	Nikkel, gelegeerd	Nickel, allié
6.1	6.1 Rame	Kupfer	Koper	Cuivre
6.2	β-Ottone, Bronzo	Kurzspanendes Messing, Bronze	β-Messing, brons	β-Laiton, Bronze
6.3	α-Ottone	Langspanendes Messing	α-Messing	α-Laiton
6.4	Bronzo ad alta resistenza	Cu-Al-Fe-Legierung, (Ampco)	Extra-sterk brons	Bronze, haute résistance
7.1	Al, Mg, non legato	Al, Mg, unlegiert	Al, Mg, ongelegeerd	Al, Mg, non-allié
7.2	Leghe di Al, Si < 0.5%	Al legiert, Si<0.5 %	Al gelegeerd, Si < 0.5%	Al allié, Si < 0.5%
7.3	Leghe di Al, Si > 0.5% < 10%	Al legiert, Si>0.5 %<10 %	Al gelegeerd, Si > 0.5% < 10%	Al allié, Si > 0.5% < 10%
7.4	Leghe di Al, Si > 10% Rinforzate Whisker Leghe di Al, Leghe di Mg	Al legiert, Si>10 % Whisker verstärkte Al-Legierung, Mg-Legierung	Al gelegeerd, Si>10% whisker versterkt Al-legierungen, Mg-legierungen	Al allié, Si>10% Alliages d'Al ou Mg, céramique renforcée
8.1	Materiali termoplastici	Thermoplaste	Thermoplasten	Thermoplastiques
8.2	Materiali plastici termoindurenti	Duroplaste	Duraplasten	Plastiques thermodurcissables
8.3	Materiali plastici rinforzati	Faserverstärkte Kunststoffe	Versterkte kunststofmaterialen	Plastiques renforcés
9.1	Cermets (materiali metallo-ceramic)	Cermets (Metallkeramik)	Cermets (metal-ceramics)	Cermets (céramiques métalliques)
10.1	Grafite standard	Graphit	Standaard Grafiet	Graphite standard

M	M	M	M	MF	MF	UNC	UNF	G	NPT
2XD	2XD	2XD	2XD	1.5XD	1.5XD	2XD	2XD	1.5XD	
HM	HM	HM	HM	HM	HM	HM	HM	HM	HM
DIN 6535HA	DIN 6535HB	DIN 6535HA	DIN 6535HA	DIN 6535HA	DIN 6535HB	DIN 6535HB	DIN 6535HB	DIN 6535HA	DIN 6535HB
J200	J205	J210	J215	J220	J225	J235	J245	J280	J260
M4 - M16	M8 - M16	M6 - M16	M6 - M16	M6 - M24	M10 - M18	1/4 - 3/4	1/4 - 3/4	1/8 - 3"	1/8 - 2"

AMG	205	205	206	206	207	207	208	209	210	211	ISO
1.1	■170B	■170B	■175B	■175B	■170B	■170B	■170B	■170B	■170B	■170B	P 1
1.2	■170B	■170B	■175B	■175B	■170B	■170B	■170B	■170B	■170B	■170B	P 1
1.3	■140B	■140B	■145B	■145B	■140B	■140B	■140B	■140B	■140B	■140B	P 2
1.4	■130B	■130B	■135B	■135B	■130B	■130B	■130B	■130B	■130B	■130B	P 3
1.5	■100B	■100B	■105B	■105B	■100B	■100B	■100B	■100B	■100B	■100B	P 4
1.6	■80B	■80B	■85B	■85B	■80B	■80B	■80B	■80B	■80B	■80B	H 1
1.7	●50A	●50A	●50A	●50A	●50A	●50A	●50A	●50A	●50A	●50A	H 3
1.8	●30A	●30A	●30A	●30A	●30A	●30A	●30A	●30A	●30A	●30A	H 4
2.1	●50A	■50A	●50A	●50A	●50A	■50A	■50A	■50A	●50A	●50A	M 1
2.2	●40A	■40A	●40A	●40A	●40A	■40A	■40A	■40A	●40A	●40A	M 3
2.3	●30A	■30A	●30A	●30A	●30A	■30A	■30A	■30A	●30A	●30A	M 2
2.4	●25A	■25A	●25A	●25A	●25A	■25A	■25A	■25A	●25A	●25A	S 2
3.1	■150B	■150B	■155B	■155B	■150B	■150B	■150B	■150B	■150B	■150B	K 1
3.2	■130B	■130B	■135B	■135B	■130B	■130B	■130B	■130B	■130B	■130B	K 2
3.3	■150B	■150B	■155B	■155B	■150B	■150B	■150B	■150B	■150B	■150B	K 3
3.4	■120B	■120B	■125B	■125B	■120B	■120B	■120B	■120B	■120B	■120B	K 4
4.1	■170B	■170B	■175B	■175B	■170B	■170B	■170B	■170B	■170B	■170B	S 1
4.2	■80B	■80B	■80B	■80B	■80B	■80B	■80B	■80B	■80B	■80B	S 2
4.3	■50B	■50B	■50B	■50B	■50B	■50B	■50B	■50B	■50B	■50B	S 3
5.1	●250B	■250B	●250B	●255B	●250B	■250B	■250B	■250B	●250B	■250B	S 1
5.2	●40A	■40A	●40A	●40A	●40A	■40A	■40A	■40A	●40A	●40A	S 2
5.3	●25A	■25A	●25A	●25A	●25A	■25A	■25A	■25A	●25A	●25A	S 3
6.1	■400B	■400B	■405B	■405B	■400B	■400B	■400B	■400B	■400B	■400B	N 3
6.2	■400B	■400B	■405B	■405B	■400B	■400B	■400B	■400B	■400B	■400B	N 4
6.3	■400B	■400B	■405B	■405B	■400B	■400B	■400B	■400B	■400B	■400B	N 3
6.4	■60A	■60A	■60A	■60A	■60A	■60A	■60A	■60A	■60A	■60A	N 4
7.1	■800C	■800C	■805C	■805C	■800C	■800C	■800C	■800C	■800C	■800C	N 1
7.2	■800C	■800C	■805C	■805C	■800C	■800C	■800C	■800C	■800C	■800C	N 1
7.3	■700C	■700C	■705C	■705C	■700C	■700C	■700C	■700C	■700C	■700C	N 1
7.4	■340B	■340B	■345B	■345B	■340B	■340B	■340B	■340B	■340B	■340B	N 2
8.1	■340C	■340C	■345C	■345C	■340C	■340C	■340C	■340C	■340C	■340C	O
8.2	■210C	■210C	■215C	■215C	■210C	■210C	■210C	■210C	■210C	■210C	O
8.3	■180C	■180C	■185C	■185C	■180C	■180C	■180C	■180C	■180C	■180C	O
9.1											H
10.1	●200C	●200C	●210C	●205C	●200C	●200C	●200C	●200C	●200C	●200C	O

M



Ø	A		B		C	
	ap= 1 x d ₁	ap= 2 x d ₁	ap= 1 x d ₁	ap= 2 x d ₁	ap= 1 x d ₁	ap= 2 x d ₁
3,2	0,010	0,005	0,011	0,006	0,017	0,012
4,1	0,009	0,007	0,012	0,008	0,014	0,011
4,8	0,012	0,009	0,015	0,010	0,017	0,014
6,5	0,017	0,014	0,027	0,017	0,030	0,025
8,2	0,021	0,018	0,034	0,029	0,040	0,033
9,9	0,024	0,020	0,039	0,024	0,048	0,032
11,6	0,031	0,025	0,050	0,031	0,059	0,035
13,6	0,039	0,032	0,062	0,051	0,071	0,048
16	0,061	0,033	0,064	0,036	0,066	0,033
19	0,085	0,044	0,089	0,048	0,095	0,044

MF



d ₁	P	A		B		C	
		ap= 3/4 x d ₁	ap= 1,5 x d ₁	ap= 3/4 x d ₁	ap= 1,5 x d ₁	ap= 3/4 x d ₁	ap= 1,5 x d ₁
4,8	0,5	0,017	0,014	0,022	0,018	0,025	0,021
6	0,75	0,023	0,018	0,033	0,027	0,037	0,030
6	1	0,020	0,016	0,029	0,023	0,032	0,026
8	1	0,025	0,020	0,041	0,033	0,045	0,037
10	1	0,034	0,028	0,055	0,045	0,069	0,056
10	1,5	0,028	0,023	0,045	0,037	0,056	0,046
12	1	0,048	0,039	0,077	0,065	0,077	0,075
12	1,5	0,040	0,032	0,065	0,053	0,076	0,062
14	1	0,060	0,049	0,084	0,079	0,084	0,084
14	1,5	0,049	0,040	0,079	0,064	0,084	0,074
16	2	0,050	0,041	0,082	0,066	0,089	0,077
20	2	0,067	0,055	0,100	0,093	0,100	0,100

UNC



d ₁	P	A		B		C	
		ap= 1 x d ₁	ap= 2 x d ₁	ap= 1 x d ₁	ap= 2 x d ₁	ap= 1 x d ₁	ap= 2 x d ₁
4,8	20	0,003	0,003	0,012	0,006	0,029	0,014
5,5	18	0,004	0,003	0,017	0,009	0,041	0,023
7,5	16	0,008	0,005	0,029	0,016	0,056	0,043
8	14	0,008	0,006	0,031	0,018	0,060	0,049
10	13	0,009	0,007	0,040	0,032	0,071	0,071
10	12	0,008	0,006	0,038	0,029	0,071	0,069
12	11	0,009	0,007	0,036	0,026	0,077	0,077
14	10	0,010	0,008	0,060	0,043	0,084	0,084

UNF



d ₁	P	A		B		C	
		ap= 1 x d ₁	ap= 2 x d ₁	ap= 1 x d ₁	ap= 2 x d ₁	ap= 1 x d ₁	ap= 2 x d ₁
4,8	0,004	0,003	0,016	0,008	0,034	0,021	
6	0,006	0,004	0,028	0,016	0,055	0,045	
8	0,013	0,007	0,037	0,025	0,063	0,058	
10	0,022	0,011	0,046	0,038	0,071	0,071	
14	0,036	0,018	0,075	0,061	0,084	0,084	

G



d ₁	A		B		C	
	ap= 1 x d ₁	ap= 2 x d ₁	ap= 1 x d ₁	ap= 2 x d ₁	ap= 1 x d ₁	ap= 2 x d ₁
3,2	0,010	0,005	0,011	0,006	0,017	0,012
4,1	0,009	0,007	0,012	0,008	0,014	0,011
4,8	0,012	0,009	0,015	0,010	0,017	0,014
6,5	0,017	0,014	0,027	0,017	0,030	0,025
16	0,061	0,033	0,064	0,036	0,066	0,033
19	0,085	0,044	0,089	0,048	0,095	0,044

NPT



d ₁	Ap=	A	B	C
7,9	Standard	0,026	0,044	0,069
9,9	Standard	0,029	0,046	0,070
15,9	Standard	0,053	0,087	0,089
19,9	Standard	0,064	0,1	0,1

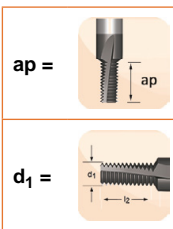

J200

- M Fresa per filettare con spirale 10°
- M Gewindefräser Spiralnut 10°
- M Draadfrees met 10° spiraalhoek
- Fraise à fileter M avec goujure hélice 10°

Filettatura interna
Innengewinde
Inwendige draad
Filetage intérieur

J205

- M Fresa per filettare con spirale 10° con fori di lubrificazione
- M Gewindefräser Spiralnut 10° innere Kühlmittelzufuhr
- M Draadfrees met 10° spiraalhoek en koelkanaal
- Fraise à fileter M avec goujure hélice 10° - à trous d'huile

Filettatura interna
Innengewinde
Inwendige draad
Filetage intérieur

J200	▪	1.1	1.2	1.3	1.4	1.5	1.6	3.1	3.2	3.3	3.4	4.1	4.2	4.3	6.1	6.2	6.3	6.4	7.1	7.2	7.3
		7.4	8.1	8.2	8.3																
	•	1.7	1.8	2.1	2.2	2.3	2.4	5.1	5.2	5.3	10.1										
J205	▪	1.1	1.2	1.3	1.4	1.5	1.6	2.1	2.2	2.3	2.4	3.1	3.2	3.3	3.4	4.1	4.2	4.3	5.1	5.2	6.1
		6.2	6.3	6.4	7.1	7.2	7.3	7.4	8.1	8.2	8.3										
	•	1.7	1.8	5.3	10.1																

J200	M		2XD	HM			DIN 6535HA	
J205	M		2XD	HM			DIN 6535HB	

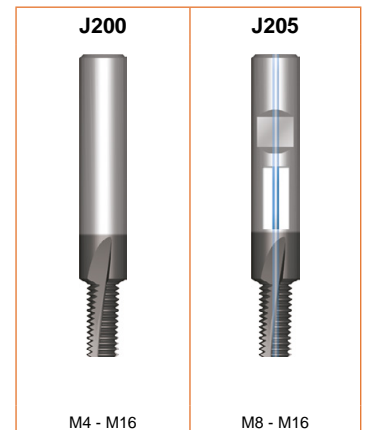
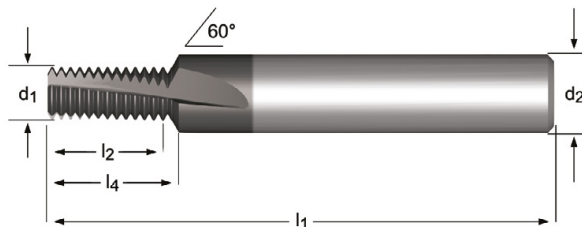

≥	P mm	d ₁ Ø mm	l ₂ mm	l ₁ mm	d ₂ Ø mm	z	l ₄ mm	J200	J205
M4	0.70	3.20	8.4	57	6	3	9.5	J2003.2X.7	
M5	0.80	4.10	11.2	57	6	3	12.1	J2004.1X.8	
M6	1.00	4.80	13.0	63	8	3	14.4	J2004.8X1.0	
M8	1.25	6.50	17.5	72	10	3	19.1	J2006.5X1.25	J2056.5X1.25
M10	1.50	8.20	21.0	83	12	3	22.8	J2008.2X1.5	J2058.2X1.50
M12	1.75	9.90	26.25	83	14	4	28.2	J2009.9X1.75	J2059.9X1.75
M14	2.00	11.60	30.0	92	16	4	32.2	J2011.6X2.0	J20511.6X2.0
M16	2.00	13.60	34.0	92	18	4	36.2	J2013.6X2.0	J20513.6X2.0

- ## J210
- M Fresa per filettare con spirale 27°
 - M Gewindefräser Spiralnut 27°
 - M Draadrees met 27° spiraalhoek
 - Fraise à fileter M avec goujure hélice 27°

Filettatura interna
Innengewinde
Inwendige draad
Filetage intérieur

- ## J215
- M Fresa per filettare con spirale 27° con fori di lubrificazione
 - M Gewindefräser Spiralnut 27° innere Kühlmittelzufuhr
 - M Draadrees met 27° spiraalhoek en koelkanaal
 - Fraise à fileter M avec goujure hélice 27° - à trous d'huile

Filettatura interna
Innengewinde
Inwendige draad
Filetage intérieur

J210; J215	▪	1.1	1.2	1.3	1.4	1.5	1.6	3.1	3.2	3.3	3.4	4.1	4.2	4.3	6.1	6.2	6.3	6.4	7.1
		7.2	7.3	7.4	8.1	8.2	8.3												
	•	1.7	1.8	2.1	2.2	2.3	2.4	5.1	5.2	5.3	10.1								

J210	M		2XD	HM		$\lambda 27^\circ$		Alcrona Pro	DIN 6535HA	
J215	M		2XD	HM		$\lambda 27^\circ$		Alcrona Pro	DIN 6535HA	

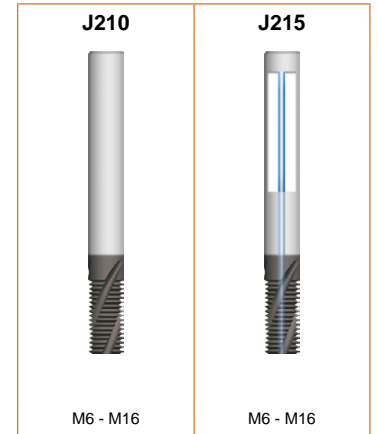
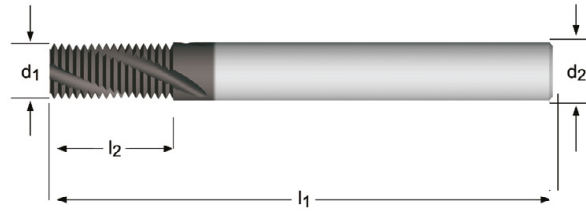

\geq	P mm	d_1 mm	l_2 mm	l_1 mm	d_2 mm	z	J210	J215
M6	1.00	4.50	13.0	57	6	3	J2104.5X1.0	J2154.5X1.0
M8	1.25	6.00	17.5	65	6	3	J2106.0X1.25	J2156.0X1.25
M10	1.50	7.50	21.0	72	8	3	J2107.5X1.5	J2157.5X1.5
M12	1.75	9.50	26.25	80	10	3	J2109.5X1.75	J2159.5X1.75
M14	2.00	10.00	30.0	83	10	4	J21010.0X2.0	J21510.0X2.0
M16	2.00	12.00	34.0	92	12	4	J21012.0X2.0	J21512.0X2.0

J220

- MF Fresa per filettare con spirale 10°
- MF Gewindefräser Spiralnut 10°
- MF draadfrees met 10° spiraalhoek
- Fraise à fileter MF avec goujure hélice 10°

Filettatura interna
Innengewinde
Inwendige draad
Filetage intérieur

J225

- MF Fresa per filettare con spirale 10° con fori di lubrificazione
- MF Gewindefräser Spiralnut 10° innere Kühlmittelzufuhr
- MF draadfrees met 10° spiraalhoek en koelkanaal
- Fraise à fileter MF avec goujure hélice 10° - à trous d'huile

Filettatura interna
Innengewinde
Inwendige draad
Filetage intérieur

J220	▪	1.1	1.2	1.3	1.4	1.5	1.6	3.1	3.2	3.3	3.4	4.1	4.2	4.3	6.1	6.2	6.3	6.4	7.1	7.2	7.3
		7.4	8.1	8.2	8.3																
	•	1.7	1.8	2.1	2.2	2.3	2.4	5.1	5.2	5.3	10.1										
J225	▪	1.1	1.2	1.3	1.4	1.5	1.6	2.1	2.2	2.3	2.4	3.1	3.2	3.3	3.4	4.1	4.2	4.3	5.1	5.2	5.3
		6.1	6.2	6.3	6.4	7.1	7.2	7.3	7.4	8.1	8.2	8.3									
	•	1.7	1.8	10.1																	

J220	MF		1.5XD	HM			DIN 6535HA	
J225	MF		1.5XD	HM			DIN 6535HB	

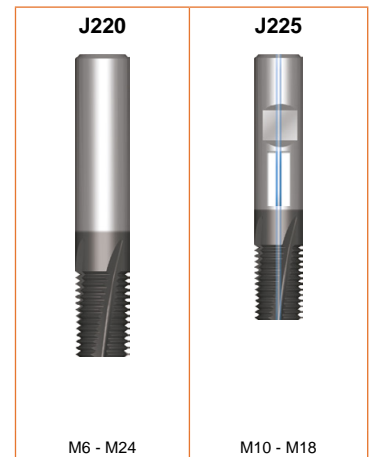
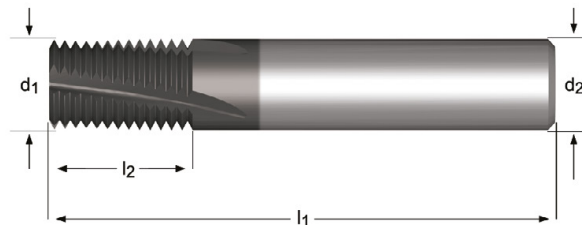

≧	P mm	d ₁ Ø mm	l ₂ mm	l ₁ mm	d ₂ Ø mm	z	J220	J225
M6	0.50	4.80	10.0	57	6	3	J2204.8X.5	
M8	0.75	6.00	12.0	57	6	3	J2206.0X.75	
M8	1.00	6.00	12.0	57	6	3	J2206.0X1.0	
M10	1.00	8.00	16.0	63	8	4	J2208.0X1.0	J2258.0X1.0
M12	1.00	10.00	20.0	72	10	4	J2210.0X1.0	J22510.0X1.0
M12	1.50	10.00	20.0	72	10	4	J2210.0X1.5	J22510.0X1.5
M14	1.00	12.00	22.0	83	12	4	J2212.0X1.0	J22512.0X1.0
M14	1.50	12.00	22.0	83	12	4	J2212.0X1.5	J22512.0X1.5
M16	1.00	14.00	26.0	83	14	5	J2214.0X1.0	J22514.0X1.0
M16	1.50	14.00	26.0	83	14	5	J2214.0X1.5	J22514.0X1.5
M18	1.50	16.00	30.0	92	16	5	J2216.0X1.5	J22516.0X1.5
M20	2.00	16.00	30.0	92	16	5	J2216.0X2.0	
M20	2.50	16.00	42.5	105	16	5	J2216.0X2.5	
M24	2.00	20.00	35.0	104	20	5	J2220.0X2.0	
M24	3.00	19.00	50.0	125	20	5	J2219.0X3.0	

- J235**
- UNC Fresa per filettare con spirale 10° con fori di lubrificazione
 - UNC Gewindefräser Spiralnut 10° innere Kühlmittelzufuhr
 - UNC Draadrees met 10° spiraalhoek en koelkanaal
 - Fraise à fileter UNC avec goujure hélice 10° - à trous d'huile

Filettatura interna
Innengewinde
Inwendige draad
Filetage intérieur

J235	▪	1.1	1.2	1.3	1.4	1.5	1.6	2.1	2.2	2.3	2.4	3.1	3.2	3.3	3.4	4.1	4.2	4.3	5.1	5.2	6.1
		6.2	6.3	6.4	7.1	7.2	7.3	7.4	8.1	8.2	8.3										
	•	1.7	1.8	5.3	10.1																

J235 **UNC** **2XD** **HM** **λ 10°** **Alcrona Pro** **DIN 6535HB**

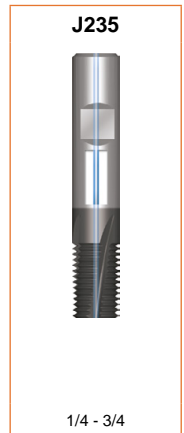
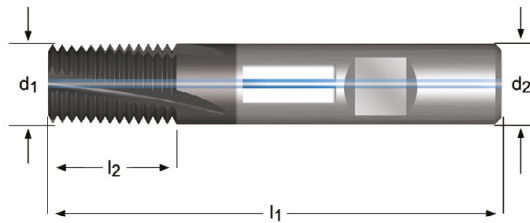

\geq	TPI	d_1 Ø mm	l_2 mm	l_1 mm	d_2 Ø mm	z	J235
1/4	20	4.80	14.0	57	6	3	J2354.8-20
5/16	18	5.50	14.0	57	6	3	J2355.5-18
3/8	16	7.50	19.0	63	8	4	J2357.5-16
7/16	14	8.00	19.0	63	8	4	J2358.0-14
1/2	13	10.00	22.0	72	10	4	J23510.0-13
9/16	12	10.00	22.0	72	10	4	J23510.0-12
5/8	11	12.00	26.0	83	12	4	J23512.0-11
3/4	10	14.00	32.0	83	14	5	J23514.0-10

J245

- UNF Fresa per filettare con spirale 10° con fori di lubrificazione
- UNF Gewindefräser Spiralnut 10° innere Kühlmittelzufuhr
- UNF Draadrees met 10° spiraalhoek en koelkanaal
- Fraise à fileter UNF avec goujure hélice 10° - à trous d'huile

Filettatura interna
Innengewinde
Inwendige draad
Filetage intérieur

J245	▪	1.1	1.2	1.3	1.4	1.5	1.6	2.1	2.2	2.3	2.4	3.1	3.2	3.3	3.4	4.1	4.2	4.3	5.1	5.2	6.1
		6.2	6.3	6.4	7.1	7.2	7.3	7.4	8.1	8.2	8.3										
	•	1.7	1.8	5.3	10.1																

J245 **UNF** **2XD** **HM** $\lambda 10^\circ$ **Alcrona Pro** **DIN 6535HB**

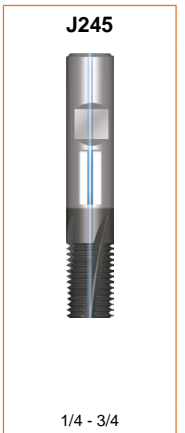
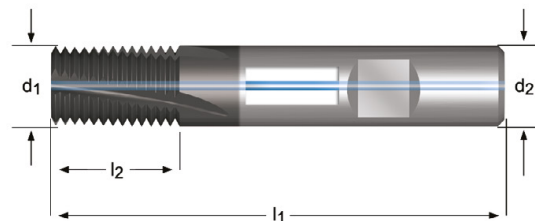

\geq	TPI	d_1 \varnothing mm	l_2 mm	l_1 mm	d_2 \varnothing mm	z	J245
1/4	28	4.80	14.0	57	6	3	J2454.8-28
5/16. 3/8	24	6.00	14.0	57	6	3	J2456.0-24
7/16. 1/2	20	8.00	19.0	63	8	4	J2458.0-20
9/16. 5/8	18	10.00	22.0	72	10	4	J24510.0-18
3/4	16	14.00	32.0	83	14	5	J24514.0-16

J280

- G(BSP) Fresa per filettare con spirale 10°
- G(BSP) Gewindefräser Spiralnut 10°
- G(BSP) Draadfrees met 10° spiraalhoek
- Fraise à fileter G(BSP) avec goujure hélice 10°

filetto interno ed esterno
Innen- und Außengewinde
In- en Uitwendige draad
Filetage intérieur et extérieur

J280	▪	1.1	1.2	1.3	1.4	1.5	1.6	3.1	3.2	3.3	3.4	4.1	4.2	4.3	6.1	6.2	6.3	6.4	7.1	7.2	7.3
		7.4	8.1	8.2	8.3																
	•	1.7	1.8	2.1	2.2	2.3	2.4	5.1	5.2	5.3	10.1										

J280

G

DORMER

1.5XD

HM

λ 10°

Alcrona Pro

DIN 6535HA

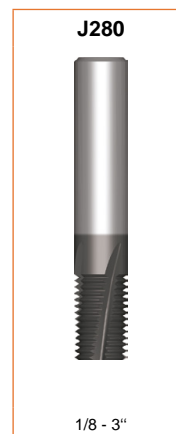
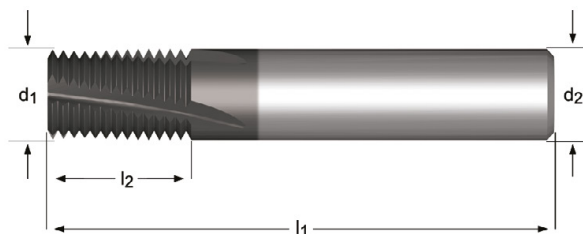

≥	TPI	d ₁ ∅ mm	l ₂ mm	l ₁ mm	d ₂ ∅ mm	z	J280
1/8	28	6.00	15.0	57	6	3	J2806.0-28
1/4	19	10.00	20.0	72	10	4	J28010.0-19
3/8	19	14.00	26.0	83	14	5	J28014.0-19
1/2. 5/8	14	16.00	30.0	92	16	5	J28016.0-14
5/8. 3/4. 7/8	14	20.00	35.0	104	20	5	J28020.0-14
1". 3"	11	25.00	45.0	121	25	6	J28025.0-11

J260

- NPT Fresa per filettare con spirale 10°
- NPT Gewindefräser Spiralnut 10°
- NPT Draadrees met 10° spiraalhoek
- Fraise à fileter NPT avec goujure hélice 10°

Filettatura interna
Innengewinde
Inwendige draad
Filetage intérieur

J260	▪	1.1	1.2	1.3	1.4	1.5	1.6	3.1	3.2	3.3	3.4	4.1	4.2	4.3	6.1	6.2	6.3	6.4	7.1	7.2	7.3
		7.4	8.1	8.2	8.3																
	•	1.7	1.8	2.1	2.2	2.3	2.4	5.1	5.2	5.3	10.1										

J260

NPT

HM

λ 10°

DIN 6535HB

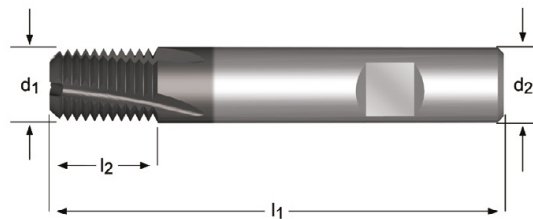

N	TPI	\varnothing_1 mm	l_2 mm	l_1 mm	\varnothing_2 mm	z	J260
1/8	27	7.90	11.50	58	8	3	J2607.9-27
1/4. 3/8	18	9.90	15.92	66	10	3	J2609.9-18
1/2. 3/4	14	15.90	20.46	82	16	4	J26015.9-14
1". 2"	11.5	19.90	27.12	92	20	5	J26019.9-11.5

E000	247	E258	250	E515	288	EP30	300
E000TIN	247	E260	256	E524	298	EP31	300
E001	247	E261	256	E531	308	EP40	321
E002	260	E263	250	E533	311	EP41	321
E002TIN	260	E266	249	E534	310	EX006G	252
E003	260	E268	269	E536	312	EX006H	252
E011	279	E275	287	E538	314	EX00TIN	252
E013	284	E278	297	E539	313	EX016H	252
E021	291	E282	319	E542	315	EX10	280
E023	293	E286	305	E544	317	EX10TIN	280
E031	301	E287	295	E545	316	EX11	280
E033	303	E288	285	E547	320	EX20	292
E041	322	E289	263	E550	328	EX21	292
E043	325	E290	269	E570	306	EX30	302
E100	230	E291	263	E600	240	EX31	302
E101	230	E292	263	E605	262	EX40	323

213 - 350



E102	230	E293	264	E606	248	EX41	323
E105	266	E294	263	E610	240	L000	342
E108	286	E295	265	E620	326	L001	343
E111	296	E296	265	E621	327	L002	344
E115	307	E297	243	E650	261	L110	348
E119	318	E298	254	E651	294	L112	349
E200	232	E299	277	E653	332	L113	339
E201	234	E300	282	E654	304	L114	340
E207	250	E303	239	E708	335	L115	341
E212	250	E382	324	E709	334	L119	337
E216	249	E383	283	E710	330	L120	345
E225	287	E384	278	E711	331	L126	338
E229	297	E390	234	E712	333	T200	226
E237	232	E412	255	E714	329	T201	226
E238	257	E414	258	E720	334	T205	228
E239	257	E422	249	E721	330	T206	228
E240	245	E423	249	EP006G	241	T210	226
E241	245	E471	246	EP006H	241	T215	229
E242	269	E472	246	EP00TiN	241		
E243	336	E473	259	EP016H	241		
E250	232	E474	259	EP10	275		
E251	232	E500	235	EP10TIN	275		
E252	234	E501	235	EP11	275		
E255	244	E504	235	EP20	290		
E256	244	E513	271	EP21	290		

	Italiano	Deutsch	Nederlands	Français
Forma Filetto		Gewindeform	Draadsoort	Forme de filet
Normativa		Standard	Norm	Standard
Tolleranza		Toleranz	Tolerantie	Tolérance
Tipo di foro		Bohrungstyp	Type gat	Type de trou
Profondità		Tiefe	Diepte	Profondeur
Materiale		Material	Materiaal	Matière
Lunghezza Imbocco		Anschnitt	Aansnijding	Chanfrein
Geometria		Geometrie	Geometrie	Géométrie
Senso di rotazione		Schneidrichtung	Snijrichting	Direction
Trattamento superficiale		Oberfläche	Oppervlaktebehandeling	Revêtement
Lubrificazione		Kühlung	Koeling	Lubrification
■ Raccomandato		Sehr gut für die Anwendung	Uitstekend voor deze toepassing	Excellent pour les applications
● Accettabile		Gut für die Anwendung	Acceptabel voor deze toepassing	Acceptable pour les applications
Esempio 10 = Velocità periferica in m/min +/- 10%		Beispiel 10 = Schnittgeschwindigkeit (m/min) +/- 10%	Voorbeeld 10 = slijnsnelheid in m/min +/- 10%	Exemple 10 = Vitesse périphérique en mètres/ minute +/- 10%
Codice prodotto		Produktbezeichnung	Productcode	Codes
Gamma diametri		Durchmesserbereich	Diameterreeks	Gamme
AMG				
1.1	Acciaio dolce magnetico	Magnetweicheisen	Automatenstaal, zachtstaal	Acier doux magnétique
1.2	Acciaio da costruzione e da cementazione	Baustahl, Einsatzstahl	Constructiestaal, inzetstaal	Acier de construction, Acier de cémentation
1.3	Acciaio al carbonio	Kohlenstoffstahl	Koolstofstaal	Acier au carbone ordinaire
1.4	Acciaio legato	Legierter Stahl	Gelegeerd staal	Acier allié
1.5	Acciaio legato / Acciaio bonificato e temprato	Legierter und vergüteter Stahl	Gelegeerd en veredeld staal	Acier allié/ Acier trempé et revenu
1.6	Acciaio legato / Acciaio bonificato e temprato	Legierter und vergüteter Stahl	Hooggelegeerd veredeld staal	Acier allié/ Acier trempé et revenu
1.7	Acciaio legato/temprato	Legierter gehärteter Stahl	Gelegeerd en gehard staal	Acier allié trempé
1.8	Acciaio legato/temprato	Legierter gehärteter Stahl	Gelegeerd en gehard staal	Acier allié trempé
2.1	Acciaio inossidabile/automatico	Rostfreier Stahl, geschwefelt	Roestvast automatenstaal	Acier inoxydable de décolletage
2.2	Austenitico	Austenitisch	Austenitisch	Austénitique
2.3	Ferritico+Austenitico, Martensitico	Ferritisch+Austenitisch, Martensitisch	Ferritisch+Austenitisch, Martensitisch	Ferritique + Austénitique, Martensitique
2.4	Acciai inossidabili con indurimento da precipitazione	Vergüteter rostfreier Stahl	Precipitatiehardend roestvast staal	Acier inoxydable Trempé
3.1	Ghisa con grafite lamellare	Grauguss	Gietijzer Lamellair	Graphite lamellaire
3.2	Ghisa con grafite lamellare	Vergüteter Grauguss	Gietijzer Lamellair	Graphite lamellaire
3.3	Ghisa malleabile con grafite sferoidale	Kugelgraphitguss, Temperguss	Nodulair gietijzer / Smeedbaar gietijzer	Graphite nodulaire/ Fonte malléable
3.4	Ghisa malleabile con grafite sferoidale	Kugelgraphitguss, Temperguss	Nodulair gietijzer / Smeedbaar gietijzer	Graphite nodulaire/ Fonte malléable
4.1	Titanio non legato	Reintitan	Titaan, ongelegeerd	Titane, non-allié
4.2	Leghe di titanio	Titan-Legierungen	Titaan, gelegeerd	Titane, allié
4.3	Leghe di titanio	Titan-Legierungen	Titaan, gelegeerd	Titane, allié
5.1	Nichel non legato	Reinnickel	Nikkel, ongelegeerd	Nickel, non-allié
5.2	Leghe di nichel	Nickel-Legierungen	Nikkel, gelegeerd	Nickel, allié
5.3	Leghe di nichel	Nickel-Legierungen	Nikkel, gelegeerd	Nickel, allié
6.1	6.1 Rame	Kupfer	Koper	Cuivre
6.2	β-Ottone, Bronzo	Kurzspanendes Messing, Bronze	β-Messing, brons	β-Laiton, Bronze
6.3	α-Ottone	Langspanendes Messing	α-Messing	α-Laiton
6.4	Bronzo ad alta resistenza	Cu-Al-Fe-Legierung, (Ampco)	Extra-sterk brons	Bronze, haute résistance
7.1	Al, Mg, non legato	Al, Mg, unlegiert	Al, Mg, ongelegeerd	Al, Mg, non-allié
7.2	Leghe di Al, Si < 0.5%	Al legiert, Si<0.5 %	Al gelegeerd, Si < 0.5%	Al allié, Si < 0.5%
7.3	Leghe di Al, Si > 0.5% < 10%	Al legiert, Si>0.5 %<10 %	Al gelegeerd, Si > 0.5% < 10%	Al allié, Si > 0.5% < 10%
7.4	Leghe di Al, Si > 10% Rinforzate Whisker Leghe di Al, Leghe di Mg	Al legiert, Si>10 % Whisker verstärkte Al-Legierung, Mg-Legierung	Al gelegeerd, Si>10% whisker versterkt Al-legierungen, Mg-legierungen	Al allié, Si>10% Alliances d'Al ou Mg, céramique renforcée
8.1	Materiali termoplastici	Thermoplaste	Thermoplasten	Thermoplastiques
8.2	Materiali plastici termoidurenti	Duroplaste	Duraplasten	Plastiques thermodurcissables
8.3	Materiali plastici rinforzati	Faserverstärkte Kunststoffe	Versterkte kunststofmaterialen	Plastiques renforcés
9.1	Cermets (materiali metallo-ceramici)	Cermets (Metallkeramik)	Cermets (metal-ceramics)	Cermets (céramiques métalliques)
10.1	Grafite standard	Graphit	Standaard Grafiet	Graphite standard

	M	M	M	M	M	M	M	M	M	M	M	M	M	M	M	M	
	DIN 371	DIN 371 \leq 10 376 \geq 12	DIN 371	DIN 371 \leq 10 376 \geq 12	DIN 371 \leq 10 376 \geq 12	DIN 2174	DIN 352	DIN 352	DIN 352	DIN 371	DIN 376	DIN 371	DIN 376	DIN 371	DIN 376	DIN 371 \leq 10 376 \geq 12	
	6H	6HX	6HX	6H	6H	6HX	6H	6HX	6H	6H	6H	6H	6H	6HX	6HX	6HX	
	2XD	2.5XD	2XD	2XD	2.5XD	3XD	1.5XD	1.5XD	1.5XD	1.5XD	1.5XD	1.5XD	1.5XD	2XD	2XD	2XD	
	HM	HM	HM	HM	HM	HM	HSS	HSS-E	HSS	HSS-E PM	HSS-E PM	HSS-E PM	HSS-E PM	HSS-E PM	HSS-E PM	HSS-E PM	
	C 2-3	C 2-3	C 2-3	C 2-3	C 2-3	C 2-3.5	C 2-3	C 2-3	C 2-3	A 6-8 C 2-3	A 6-8 C 2-3	C 2-3	C 2-3	C 2-3	C 2-3	C 2-3	
				$\lambda 15^\circ$ 	$\lambda 15^\circ$ 												
	TICN	Super B	TICN			TICN		ST						ST	ST	TAIN	
	T200	T201	T210	T205	T206	T215	E100	E102	E101	E200	E250	E237	E251	E201	E252	E390	
	M3 - M12	M5 - M16	M3 - M12	M3 - M12	M5 - M12	M3 - M10	M1.6 - M52	M3 - M30	M4 - M16	M2 - M10	M3 - M52	M3 - M10	M12 - M24	M3 - M10	M8 - M24	M3 - M20	
AMG	226	226	226	228	228	229	230	230	230	232	232	232	232	234	234	234	ISO
1.1						■60	●1	●1	●1	●12	●12	●12	●12				P 1
1.2						■60	●1	●1	●1	●10	●10	●10	●10				P 1
1.3						■60	●1	●1	●1	●8	●8	●8	●8				P 2
1.4						■40	●1	●1	●1	●6	●6	●6	●6				P 3
1.5						■30	●1	●1	●1	●5	●5	●5	●5				P 4
1.6																	H 1
1.7	■6		●6														H 3
1.8	●4		■4														H 4
2.1						■25		●1									M 1
2.2						■25		●1									M 3
2.3						■25		●1									M 2
2.4						●25											S 2
3.1	●60	■60		●40	●40		●1	●1	●1	●14	●14	●14	●14	■15	■15	■30	K 1
3.2	●30	■25		●15	●15		●1	●1	●1	●8	●8	●8	●8	■8	■8	■25	K 2
3.3		●38		■25	■25		●1	●1	●1	●12	●12	●12	●12	■15	■15	■35	K 3
3.4		●33		■15	■15		●1	●1	●1					●8	●8	●25	K 4
4.1								●1									S 1
4.2								●1									S 2
4.3								●1									S 3
5.1						■35		●1									S 1
5.2						●15		●1									S 2
5.3								●1									S 3
6.1						●40	●1	●1	●1								N 3
6.2							●1	●1	●1	●16	●16	●16	●16	●20	●20	●30	N 4
6.3						●80	●1	●1	●1	●12	●12	●12	●12				N 3
6.4	●7	●10					●1	●1	●1					●5	●5	●5	N 4
7.1						■70											N 1
7.2						■80	●1	●1	●1	●20	●20	●20	●20				N 1
7.3		●50		■35	■35	■80	●1	●1	●1	●12	●12	●12	●12				N 1
7.4	●60	■40		■30	■30		●1	●1	●1					●15	●15	●20	N 2
8.1																	O
8.2	●50	●25		●25	●25		●1	●1	●1	●8	●8	●8	●8	■10	■10	■15	O
8.3	●30	●15		●15	●15		●1	●1	●1								O
9.1																	H
10.1	●25	■25															O

	M	M	M	M	M	M	M	M	M	M	M	M	M	M	M	M	
	ISO 529	ISO 529	ISO 529	DIN 357	ISO 2283	ISO 2283	DIN 3714<10 376>12	DIN 3714<10 376>12	DIN 3714<10 376>12	DIN 3714<10 376>12	DIN 3714<10 376>12	DIN 3714<10 376>12	DIN 3714<10 376>12	DIN 3714<10 376>12	DIN 3714<10 376>12	DIN 3714<10 376>12	
	6H	6H	6H	6H	6H	6H	6H	6G	6H	6H	6H	6H	6H	6H	6H	6H	
	1.5XD	1.5XD	1.5XD	2XD	1.5XD	1.5XD	2.5XD	2.5XD	2.5XD	2.5XD	2.5XD	2.5XD	2.5XD	2.5XD	2.5XD	2.5XD	
	HSS	HSS	HSS	HSS-E	HSS-E PM	HSS-E PM	HSS-E PM	HSS-E PM	HSS-E PM	HSS-E PM	HSS-E PM	HSS-E PM	HSS-E PM	HSS-E PM	HSS-E PM	HSS-E PM	
				D18-20 C 2-3	C 2-3	C 2-3	B 3.5-5	B 3.5-5	B 3.5-5	B 3.5-5	B 3.5-5	B 3.5-5	B 3.5-5	B 3.5-5	B 3.5-5	B 3.5-5	
			TiN			TiN			TiN	ST	Cr		TiAIN Top	ST	Super B		
	E500	E501	E504	E303	E600	E610	EP006H	EP006G	EP00TIN	EP016H	E297	E255	E256	E240	E241	E471	
	M1 - M56	M3 - M24	M3 - M24	M3 - M20	M3 - M30	M3 - M16	M2 - M30	M3 - M20	M3 - M30	M2 - M30	M3 - M30	M3 - M20	M3 - M20	M3 - M30	M3 - M20	M3 - M20	
											SHARK LINE	SHARK LINE	SHARK LINE	SHARK LINE	SHARK LINE	SHARK LINE	
AMG	235	235	235	239	240	240	241	241	241	241	243	244	244	245	245	246	ISO
1.1	●7	●7	●14	●12	●7	●14	■25	■25	■40	■25	■25					●25	P 1
1.2	●6	●6	●12	●10	●6	●12	■22	■22	■40	■22	■22					●22	P 1
1.3	●5	●5	●10	●8	●5	●10	■18	■18	■32	■18	■18					●18	P 2
1.4	●4	●4	●8	●6	●4	●8	■16	■16	■27	■16	●16	■16	■30			●16	P 3
1.5	●3	●3	●6	●5	●3	●6	■10	■10	■13	■10	●10	●7	■17	●7	●10		P 4
1.6							●5	●5	●11	●5		●4	●11				H 1
1.7																	H 3
1.8																	H 4
2.1									■8	●7				■8	■14		M 1
2.2									■7	●6			■7	■10			M 3
2.3									●5	●4			■5	■6			M 2
2.4																	S 2
3.1	●12	●12	■18	●14	●12	■18	●15	●15	●22	●15							K 1
3.2	●7	●7	■12	●8	●7	■12	●8	●8	●18	●8							K 2
3.3	●10	●10	■22	●12	●10	■22	●15	●15	●25	●15							K 3
3.4	●5	●5	●12		●5	●12	●8	●8	●18	●8							K 4
4.1							●10	●10	●15								S 1
4.2							●5	●5	●7			●2	●3				S 2
4.3																	S 3
5.1							●12	●12	●18								S 1
5.2							●5	●5	●8			●2	●3				S 2
5.3																	S 3
6.1	●4	●4			●4		■12	■12	■18		■12					●12	N 3
6.2	●10	●10	●20	●16	●10	●20	●30	●30	●45		●30					■30	N 4
6.3	●7	●7	●14	●12	●7	●14	■20	■20	■35		■20					■20	N 3
6.4	●2	●2	●4		●2	●4											N 4
7.1							■16	■16								■16	N 1
7.2	●12	●12	●24	●20	●12	●24	■35	■35								■35	N 1
7.3	●7	●7	●14	●12	●7	●14	■20	■20	■30							■20	N 1
7.4	●5	●5	●10		●5	●10	■15	■15	■22							●15	N 2
8.1							●30	●30								■25	O
8.2	●5	●5	●10	●8	●5	●10			●45								O
8.3	●3	●3	●6		●3	●6											O
9.1																	H
10.1																	O

	M	M	M	M	M	M	M	M	M	M	M	M	M	M	M	M	
	DIN 371<10 376>12	ISO 529	ISO 529	ISO 529	ISO 2283	DIN 371	DIN 376	DIN 371	DIN 376	DIN 371	DIN 376	DIN 371	DIN 376	DIN 371<10 376>12	DIN 371<10 376>12	DIN 371<10 376>12	
	6H	6H	6H	6H	6H	6H	6H	6H	6H	6H	6H	6H	6H	6H	6G	6H	
	2.5XD	2.5XD	2.5XD	2.5XD	2.5XD	3XD	3XD	3XD	3XD	1.5XD	1.5XD	1.5XD	1.5XD	2.5XD	2.5XD	2.5XD	
	HSS-E PM	HSS-E PM	HSS-E PM	HSS-E PM	HSS-E PM	HSS-E PM	HSS-E PM	HSS-E PM	HSS-E PM	HSS-E PM	HSS-E PM	HSS-E PM	HSS-E PM	HSS-E PM	HSS-E PM	HSS-E PM	
	B 3.5-5	B 3.5-5	B 3.5-5	B 3.5-5	B 3.5-5	B 3.5-5	B 3.5-5	B 3.5-5	B 3.5-5	C 2-3	C 2-3	C 2-3	C 2-3	C 2-3	C 2-3	C 2-3	
	Super B	TiN	TiN	ST	TiN	TiN	TiN	TiN	TiN	λ15°	λ15°	λ15°	λ15°	λ45°	λ45°	λ45°	
	E472	E000	E000TIN	E001	E606	E216	E266	E422	E423	E207	E258	E212	E263	EX006H	EX006G	EX00TIN	
	M3 - M20	M1.6 - M24	M3 - M20	M1.6 - M24	M3 - M24	M3 - M10	M12 - M24	M3 - M10	M12 - M24	M2 - M10	M4 - M36	M3 - M10	M12 - M36	M2 - M64	M3 - M20	M3 - M30	
AMG	246	247	247	247	248	249	249	249	249	250	250	250	250	252	252	252	ISO
1.1		■25	■40	■25	●20	●22	●22	●35	●35			●35	●35	■25	■25	■40	P 1
1.2	●40	■22	■40	■22	●18	■20	■20	■35	■35	●20	●20	●35	●35	■22	■22	■40	P 1
1.3	●32	■18	■32	■18	●14	■16	■16	■28	■28	■16	■16	■28	■28	■18	■18	■32	P 2
1.4		■16	■27	■16	●10	■12	■12	■24	■24	■12	■12	■24	■24	■16	■16	■27	P 3
1.5		■10	■13	■10	●5	●7	●7	●10	●10	●7	●7	●10	●10	■10	■10	■13	P 4
1.6		●5	●11	●5	●3												H 1
1.7																	H 3
1.8																	H 4
2.1			■8	●7	●6											■8	M 1
2.2			■7	●6	●4											■7	M 3
2.3			●5	●4	●3											●5	M 2
2.4																	S 2
3.1		●15	●22	●15		●12	●12	●18	●18							●22	K 1
3.2		●8	●18	●8		●7	●7	●15	●15							●18	K 2
3.3		●15	●25	●15		●10	●10	●20	●20							●25	K 3
3.4		●8	●18	●8		●5	●5	●15	●15							●18	K 4
4.1		●10	●15			●15	●15	●27	●27					●10	●10	●15	S 1
4.2		●5	●7									●10	●10	●5	●5	●7	S 2
4.3					●3	●4	●4	●5	●5			●7	●7				S 3
5.1		●12	●18		●10	●12	●12	●20	●20					●12	●12	●18	S 1
5.2		●5	●8		●4	●5	●5	●8	●8					●5	●5	●8	S 2
5.3																	S 3
6.1		■12	■18		●10	●12	●12	●18	●18								N 3
6.2	■45	■30	■45			●30	●30	●45	●45								N 4
6.3	■35	■20	■35		●15	●20	●20	●35	●35								N 3
6.4																	N 4
7.1	●35	■16			●10	●16	●16	●25	●25					■16	■16		N 1
7.2	■45	■35			●25	●35	●35	●45	●45	●30	●30	●35	●35	■35	■35		N 1
7.3	■30	■20	■30		●13	●20	●20	●30	●30	●15	●15	●20	●20	■20	■20	■30	N 1
7.4	■20	■15	■22		●10	●15	●15	●20	●20					■15	■15	■22	N 2
8.1	●30	●30			●20	●25	●25	●30	●30								O
8.2			●45														O
8.3																	O
9.1																	H
10.1																	O

	M	M	M	M	M	M	M	M	M	M	M	M	M	M	M	M		
	DIN 371 \leq 10 376 \geq 12	DIN 371 \leq 10 376 \geq 12	DIN 371 \leq 10 376 \geq 12	DIN 371 \leq 10 376 \geq 12	DIN 371 \leq 10 376 \geq 12	DIN 371 \leq 10 376 \geq 12	DIN 371 \leq 10 376 \geq 12	DIN 371 \leq 10 376 \geq 12	DIN 371 \leq 10 376 \geq 12	DIN 371 \leq 10 376 \geq 12	ISO 529	ISO 529	ISO 529	DORMER ISO 2283	ISO 2283	DIN 2174		
	6H	6H	6H	6H	6H	6H	6H	6H	6H	6H	6H	6H	6H	6H	6H	6HX		
	HSS-E PM	HSS-E PM	HSS-E PM	HSS-E PM	HSS-E PM	HSS-E PM	HSS-E PM	HSS-E PM	HSS-E PM	HSS-E PM	HSS-E PM	HSS-E PM	HSS-E PM	HSS	HSS-E PM	HSS-E		
	C 2-3	C 2-3	C 2-3	C 2-3	C 2-3	C 2-3	C 2-3	C 2-3	C 2-3	C 2-3	C 2-3	C 2-3	C 2-3	C 2-3	C 2-3	C 2-3.5		
	SHARK LINE	SHARK LINE	SHARK LINE	SHARK LINE	SHARK LINE	SHARK LINE	SHARK LINE	SHARK LINE	SHARK LINE	SHARK LINE								
	EX016H	E298	E412	E260	E261	E238	E239	E414	E473	E474	E002	E002TIN	E003	E650	E605	E291		
	M2 - M64	M3 - M30	M3 - M30	M3 - M20	M3 - M20	M3 - M30	M3 - M20	M3 - M20	M3 - M20	M3 - M20	M2 - M24	M3 - M20	M2 - M24	M3 - M16	M3 - M20	M1.6 - M16		
AMG	252	254	255	256	256	257	257	258	259	259	260	260	260	261	262	263	ISO	
1.1	■25	■25	■50						●25		■25	■40	■25	●25		■30	P 1	
1.2	■22	■22	■50						●22	●40	■22	■40	■22	●22	●18	■27	P 1	
1.3	■18	■18	■35						●18	●32	●18	■32	■18	●18	●14	■23	P 2	
1.4	■16	●16	■30	■16	■35				●16	●27		■16	■27	■16	●15	●10	■20	P 3
1.5	■10	●10	■16	●7	■20	●7			●10	●13		■10	■13	■10		●5		P 4
1.6				●4	●11													H 1
1.7																		H 3
1.8																		H 4
2.1	■7		●14			■8	■14	■16				■8	●7		●6			M 1
2.2	■6		●10			■7	■10	■12				■7	●6		●4			M 3
2.3	●4		●6			■5	■6	■8				●5	●4		●3			M 2
2.4								■6										S 2
3.1												●22						K 1
3.2												●18		●8				K 2
3.3												●25						K 3
3.4												●18						K 4
4.1												●10		●15				S 1
4.2				●2	●3							●5	●7					S 2
4.3																		S 3
5.1												●12	●18					S 1
5.2				●2	●3							●5	●8		●4			S 2
5.3																		S 3
6.1		■12							●12									N 3
6.2		●30							■30	■45				●30				N 4
6.3		■20							■20	●35				●20				N 3
6.4																		N 4
7.1			●16						■16	●35	■16			●18	●10	■26		N 1
7.2			●16						■35	■45	■35			●35	●25	■38		N 1
7.3			●35						■20	■30	■20	■30			●13	●22		N 1
7.4			●35						●15	■20	■15	■22			●10			N 2
8.1									■25	●30				●30				O
8.2																		O
8.3																		O
9.1																		H
10.1																		O











	M	M	M	M	M	M	MF	MF	MF	MF	MF	MF	MF	MF	MF	
	DIN 2174	DIN 2174	DIN 2174	DIN 2174	DIN 2174	DIN 2174	DIN 2181	DIN 374	DIN 371	DIN 374	ISO 529	DIN 374	DIN 374	DIN 374	DIN 374	
	6HX	6HX	6HX	6HX	6GX	6GX	6H	6H	6H	6H	6H	6H	6H	6H	6H	
	HSS-E	HSS-E	HSS-E	HSS-E	HSS-E	HSS-E	HSS	HSS-E PM	HSS-E PM	HSS-E PM	HSS	HSS-E PM	HSS-E PM	HSS-E PM	HSS-E PM	
	C 2-3.5	C 2-3.5	C 2-3.5	E 1.5-2	C 2-3.5	E 1.5-2	C 2-3	C 2-3	C 2-3	C 2-3		B 3.5-5	B 3.5-5	B 3.5-5	B 3.5-5	
	E292	E294	E289	E293	E295	E296	E105	E268	E242	E290	E513	EP10	EP10TIN	EP11	E299	
	M1.6 - M16	M3 - M16	M5 - M12	M3 - M16	M3 - M12	M3 - M10	M2.5 - M50	M4 - M50	M8 - M10	M12 - M24	M3 - M50	M4 - M30	M8 - M20	M4 - M30	M4 - M30	
AMG	263	263	263	264	265	265	266	269	269	269	271	275	275	275	277	ISO
1.1	■55	■55	■55	■55	■55	■55	●1	●12	●12	●12	●7	■25	■40	■25	■25	P 1
1.2	■50	■50	■50	■50	■50	■50	●1	●10	●10	●10	●6	■22	■40	■22	■22	P 1
1.3	■45	■45	■45	■45	■45	■45	●1	●8	●8	●8	●5	■18	■32	■18	■18	P 2
1.4	■40	■40	■40	■40	■40	■40	●1	●6	●6	●6	●4	■16	■27	■16	●16	P 3
1.5	●20	●20	●20	●20	●20	●20	●1	●5	●5	●5	●3	■10	■13	■10	●10	P 4
1.6												●5	●11	●5		H 1
1.7																H 3
1.8																H 4
2.1	■18	■18	■18	■18	■18	■18						■8	●7			M 1
2.2	■15	■15	■15	■15	■15	■15						■7	●6			M 3
2.3	●10	●10	●10	●10	●10	●10						●5	●4			M 2
2.4																S 2
3.1							●1	●14	●14	●14	●12	●15	●22	●15		K 1
3.2							●1	●8	●8	●8	●7	●8	●18	●8		K 2
3.3							●1	●12	●12	●12	●10	●15	●25	●15		K 3
3.4							●1				●5	●8	●18	●8		K 4
4.1	■35	■35	■35	■35	■35	■35						●10	●15			S 1
4.2												●5	●7			S 2
4.3																S 3
5.1	■20	■20	■20	■20	■20	■20						●12	●18			S 1
5.2	●8	●8	●8	●8	●8	●8						●5	●8			S 2
5.3																S 3
6.1	●25	●25	●25	●25	●25	●25	●1				●4	■12	■18		■12	N 3
6.2							●1	●16	●16	●16	●10	■30	■45		●30	N 4
6.3	●40	●40	●40	●40	●40	●40	●1	●12	●12	●12	●7	■20	■35		■20	N 3
6.4							●1				●2					N 4
7.1	■55	■55	■55	■55	■55	■55						■16				N 1
7.2	■55	■55	■55	■55	■55	■55	●1	●20	●20	●20	●12	■35				N 1
7.3	■40	■40	■40	■40	■40	■40	●1	●12	●12	●12	●7	■20	■30			N 1
7.4	●25	●25	●25	●25	●25	●25	●1				●5	■15	■22			N 2
8.1												●30				O
8.2							●1	●8	●8	●8	●5		●45			O
8.3							●1				●3					O
9.1																H
10.1																O

	MF	MF	MF	MF	MF	MF	MF	MF	MF	UNC	UNC	UNC	UNC	UNC	UNC	UNC	UNC	
	DIN 374	ISO 529	DIN 374	DIN 374	DIN 374	DIN 374	DIN 374	ISO 529	DIN 2174	DIN 352	DIN 371	DIN 376	ISO 529	DIN 2184-1	DIN 2184-1	ISO 529	DIN 2184-1	
	6H	6H	6H	6H	6H	6H	6H	6H	6HX	2B	2B	2B	2B	2B	2B	2B	2B	
	2.5XD	2.5XD	2.5XD	2.5XD	2.5XD	2XD	2XD	2.5XD	3XD	1.5XD	1.5XD	1.5XD	1.5XD	2.5XD	2.5XD	2.5XD	2.5XD	
	HSS-E PM	HSS-E PM	HSS-E PM	HSS-E PM	HSS-E PM	HSS-E PM	HSS-E PM	HSS-E PM	HSS-E	HSS	HSS-E PM	HSS-E PM	HSS	HSS-E PM	HSS-E PM	HSS-E PM	HSS-E PM	
	B 3.5-5	B 3.5-5	C 2-3	C 2-3	C 2-3	C 2-3	C 2-3	C 2-3	C 2-3.5	C 2-3	C 2-3	C 2-3		B 3.5-5	B 3.5-5	B 3.5-5	C 2-3	
			λ45°	λ45°	λ45°	λ40°	λ40°	λ45°									λ45°	
	ST	ST		TiN	ST	Cr	ST	ST	TiN							ST	ST	
	E384	E011	EX10	EX10TiN	EX11	E300	E383	E013	E288	E108	E225	E275	E515	EP20	EP21	E021	EX20	
	M6 - M20	M4 - M24	M4 - M30	M8 - M20	M4 - M30	M4 - M30	M6 - M20	M4 - M22	M5 - M12	No.5 - 1"	No.2 - 1/4	5/16 - 1.1/2	No.1 - 2"	No.4 - 1"	No.4 - 1"	No.2 - 1"	No.4 - 1"	
AMG	278	279	280	280	280	282	283	284	285	286	287	287	288	290	290	291	292	ISO
1.1		■25	■25	■40	■25	■25		■25	■55	●1	●12	●12	●7	■25	■25	■25	■25	P 1
1.2		■22	■22	■40	■22	■22		■22	■50	●1	●10	●10	●6	■22	■22	■22	■22	P 1
1.3		■18	■18	■32	■18	■18		■18	■45	●1	●8	●8	●5	■18	■18	■18	■18	P 2
1.4		■16	■16	■27	■16	●16		■16	■40	●1	●6	●6	●4	■16	■16	■16	■16	P 3
1.5	●7	■10	■10	■13	■10	●10	●7	■10	●20	●1	●5	●5	●3	■10	■10	■10	■10	P 4
1.6		●5												●5	●5	●5		H 1
1.7																		H 3
1.8																		H 4
2.1	■8	●7		■8	■7		■8	●7	■18						●7	●7		M 1
2.2	■7	●6		■7	■6		■7	●6	■15						●6	●6		M 3
2.3	■5	●4		●5	●4		■5	●4	●10						●4	●4		M 2
2.4																		S 2
3.1		●15		●22						●1	●14	●14	●12	●15	●15	●15		K 1
3.2		●8		●18						●1	●8	●8	●7	●8	●8	●8		K 2
3.3		●15		●25						●1	●12	●12	●10	●15	●15	●15		K 3
3.4		●8		●18						●1			●5	●8	●8	●8		K 4
4.1			●10	●15					■35					●10			●10	S 1
4.2			●5	●7										●5			●5	S 2
4.3																		S 3
5.1			●12	●18					■20					●12			●12	S 1
5.2			●5	●8					●8					●5			●5	S 2
5.3																		S 3
6.1						■12			●25	●1			●4	■12				N 3
6.2						●30				●1	●16	●16	●10	■30				N 4
6.3						■20			●40	●1	●12	●12	●7	■20				N 3
6.4										●1			●2					N 4
7.1			■16						■55					■16			■16	N 1
7.2			■35						■55	●1	●20	●20	●12	■35			■35	N 1
7.3			■20	■30					■40	●1	●12	●12	●7	■20			■20	N 1
7.4			■15	■22					●25	●1			●5	■15			■15	N 2
8.1														●30				O
8.2										●1	●8	●8	●5					O
8.3										●1			●3					O
9.1																		H
10.1																		O





	UNC	UNC	UNC	UNC	UNF	UNF	UNF	UNF	UNF	UNF	UNF	UNF	UNF	UNF	UNF	UN	BSW		
	DIN 2184-1	ISO 529	DORMER DIN	DIN 2184-1	DIN 2181	DIN 371	DIN 374	ISO 529	DIN 2184-1	DIN 2184-1	ISO 529	DIN 2184-1	DIN 2184-1	ISO 529	DORMER DIN	DIN 2184-1	ISO 529	DIN 351	
	2B	2B	2B	2BX	2B	2B	2B	2B	2B	2B	2B	2B	2B	2B	Medium	2BX	2B	Medium	
	HSS-E PM	HSS-E PM	HSS	HSS-E	HSS	HSS-E PM	HSS-E PM	HSS	HSS-E PM	HSS-E PM	HSS-E PM	HSS-E PM	HSS-E PM	HSS-E PM	HSS	HSS-E	HSS	HSS	
	C 2-3	C 2-3	C 2-3	C 2-3.5	C 2-3	C 2-3	C 2-3		C 2-3	C 2-3	B 3.5-5	C 2-3	C 2-3	C 2-3	C 2-3	C 2-3.5	C 2-3	C 2-3	
	EX21	E023	E651	E287	E111	E229	E278	E524	EP30	EP31	E031	EX30	EX31	E033	E654	E286	E570	E115	
	No.4 - 1"	No.2 - 1"	No.6 - 5/8"	No.4 - 1/2"	No.5 - 1"	No.2 - 1/4"	5/16 - 1.1/2"	No.0 - 1.1/2"	No.8 - 1"	No.8 - 1"	No.8 - 1"	No.8 - 1"	No.8 - 1"	No.8 - 1"	No.8 - 5/8"	No.4 - 1/2"	1/4 - 1.5/16"	1/8 - 1"	
AMG	292	293	294	295	296	297	297	298	300	300	301	302	302	303	304	305	306	307	ISO
1.1	■25	■25	●25	■55	●1	●12	●12	●7	■25	■25	■25	■25	■25	■25	●25	■55	●7	●1	P 1
1.2	■22	■22	●22	■50	●1	●10	●10	●6	■22	■22	■22	■22	■22	■22	●22	■50	●6	●1	P 1
1.3	■18	■18	●18	■45	●1	●8	●8	●5	■18	■18	■18	■18	■18	■18	●18	■45	●5	●1	P 2
1.4	■16	■16	●15	■40	●1	●6	●6	●4	■16	■16	■16	■16	■16	■16	●15	■40	●4	●1	P 3
1.5	■10	■10		●20	●1	●5	●5	●3	■10	■10	■10	■10	■10	■10		●20	●3	●1	P 4
1.6									●5	●5	●5				●5				H 1
1.7																			H 3
1.8																			H 4
2.1	■7	●7		■18					●7	●7			■7	●7		■18			M 1
2.2	■6	●6		■15					●6	●6			■6	●6		■15			M 3
2.3	●4	●4		●10					●4	●4			●4	●4		●10			M 2
2.4																			S 2
3.1					●1	●14	●14	●12	●15	●15	●15						●12	●1	K 1
3.2			●8		●1	●8	●8	●7	●8	●8	●8				●8		●7	●1	K 2
3.3					●1	●12	●12	●10	●15	●15	●15						●10	●1	K 3
3.4					●1			●5	●8	●8	●8						●5	●1	K 4
4.1				■35					●10			●10				■35			S 1
4.2								●5				●5							S 2
4.3																			S 3
5.1				■20				●12				●12				■20			S 1
5.2				●8				●5				●5				●8			S 2
5.3																			S 3
6.1				●25	●1			●4	■12							●25	●4	●1	N 3
6.2			●30		●1	●16	●16	●10	●30						●30		●10	●1	N 4
6.3			●20	●40	●1	●12	●12	●7	■20					●20	●40	●7	●1	●1	N 3
6.4					●1			●2									●2	●1	N 4
7.1			●18	■55					■16			■16			●18	■55			N 1
7.2			●35	■55	●1	●20	●20	●12	■35			■35			●35	■55	●12	●1	N 1
7.3				■40	●1	●12	●12	●7	■20			■20				■40	●7	●1	N 1
7.4				●25	●1			●5	■15			■15				●25	●5	●1	N 2
8.1			●30						●30										O
8.2					●1	●8	●8	●5									●5	●1	O
8.3					●1			●3									●3	●1	O
9.1																			H
10.1																			O

	BSW	BSW	BSW	BSF	BSF	BSF	BA	BA	BA	G	G	G	G	G	G	G	
	ISO 529	ISO 529	ISO 529	ISO 529	ISO 529	ISO 529	ISO 529	ISO 529	ISO 529	DIN 5157	DIN 5156	ISO 2284	DIN 5156	DIN 5156	DORMER ISO	DIN 5156	
	Medium	Medium	Medium	Medium	Medium	Medium	Normal	Normal	Normal	Normal	Normal	Normal	Normal	Normal	Normal	Normal	
	1.5XD	2.5XD	2XD	1.5XD	2.5XD	2XD	1.5XD	2.5XD	2XD	1.5XD	1.5XD	1.5XD	2.5XD	2.5XD	2.5XD	2.5XD	
	HSS	HSS	HSS	HSS	HSS	HSS	HSS	HSS	HSS	HSS	HSS-E PM	HSS	HSS-E PM	HSS-E PM	HSS-E PM	HSS-E PM	
		B 3.5-5	C 2-3		B 3.5-5	C 2-3		B 3.5-5	C 2-3	C 2-3	C 2-3		B 3.5-5	B 3.5-5	B 3.5-5	C 2-3	
		ST	ST		ST	ST		ST	ST				ST	ST	ST		
	E531	E534	E533	E536	E539	E538	E542	E545	E544	E119	E282	E547	EP40	EP41	E041	EX40	
	1/8 - 1"	1/8 - 3/4	1/8 - 3/4	3/16 - 1"	1/4 - 1/2	1/4 - 1/2	No.10 - No.0	No.10 - No.2	No.8 - No.2	1/8 - 3"	1/8 - 1.1/2	1/8 - 2"	1/8 - 1"	1/8 - 1"	1/8 - 3/4	1/8 - 1.1/2	
AMG	308	310	311	312	313	314	315	316	317	318	319	320	321	321	322	323	ISO
1.1	●7	■20		●22	■20		●7	■20		●1	●12	●7	■25	■25	■25	■25	P 1
1.2	●6	■18	■18	●20	■18	■18	●6	■18	■18	●1	●10	●6	■22	■22	■22	■22	P 1
1.3	●5	■14	■14	●16	■14	■14	●5	■14	■14	●1	●8	●5	■18	■18	■18	■18	P 2
1.4	●4	■10	■10	●12	■10	■10	●4	■10	■10	●1	●6	●4	■16	■16	■16	■16	P 3
1.5	●3	●5	●5	●7	●5	●5	●3	●5	●5	●1	●5	●3	■10	■10	■10	■10	P 4
1.6		●3		●4	●3			●3					●5	●5	●5		H 1
1.7																	H 3
1.8																	H 4
2.1		■6	■6	●7	■6	■6		●6	■6						●7	●7	M 1
2.2		■4	■4	●5	■4	■4		●4	■4						●6	●6	M 3
2.3		■3	■3	●7	■3	■3		●3	■3						●4	●4	M 2
2.4																	S 2
3.1	●12			●12			●12			●1	●14	●12	●15	●15	●15		K 1
3.2	●7			●7			●7			●1	●8	●7	●8	●8	●8		K 2
3.3	●10			●10			●10			●1	●12	●10	●15	●15	●15		K 3
3.4	●5			●5			●5			●1		●5	●8	●8	●8		K 4
4.1													●10			●10	S 1
4.2													●5			●5	S 2
4.3		●3			●3			●3									S 3
5.1		●10			●10			●10					●12			●12	S 1
5.2		●4	●4		●4	●4		●4	●4				●5			●5	S 2
5.3																	S 3
6.1	●4	●10		■12	●10		●4	●10		●1		●4	■12				N 3
6.2	●10			●30			●10	●10		●1	●16	●10	●30				N 4
6.3	●7	●15		●20	●15		●7	●15		●1	●12	●7	■20				N 3
6.4	●2			●4			●2			●1		●2					N 4
7.1		●10	●10		●10	●10		●10	●10				■16			■16	N 1
7.2	●12	●25	●25	●35	●25	●25	●12	●25	●25	●1	●20	●12	■35			■35	N 1
7.3	●7	●13	●13	●20	●13	●13	●7	●13	●13	●1	●12	●7	■20			■20	N 1
7.4	●5	●10	●10	●15	●10	●10	●5	●10	●10	●1		●5	■15			■15	N 2
8.1		●20			●20			●20					●30				O
8.2	●5			●12			●5			●1	●8	●5					O
8.3	●3			●7			●3			●1		●3					O
9.1																	H
10.1																	O

	G	G	G	EGM	EGM	Rc	NPT	NPT	NPT	NPT	NPT	NPTF	NPSF	NPSF	NPSM	PG	
	DIN 5156	DIN 5156	DORMER ISO	DORMER ISO	DORMER ISO	ISO 2284	DORMER ANSI	ANSI B94.9	ANSI B94.9	ANSI B94.9	ANSI	ANSI B94.9	ANSI B94.9	ANSI B94.9	ANSI B94.9	DIN 40432	
	Normal	Normal	Normal	6H	6H	Normal	Normal	Normal	Normal	Normal	Normal	Normal	Normal	Normal	Normal	Normal	
	2.5XD	2XD	2.5XD	1.5XD	2XD	1.5XD	1.5XD	1.5XD	1.5XD	1.5XD	1.5XD	1.5XD	1.5XD	1.5XD	1.5XD	1.5XD	
	HSS-E PM	HSS-E PM	HSS-E PM	HSS	HSS	HSS	HSS-E PM	HSS	HSS	HSS	HSS	HSS	HSS	HSS	HSS	HSS	
	C 2-3	C 2-3	C 2-3	C 2-3	C 2-3	C 2-3	C 2-3	C 2-3	C 2-3	C 2-3		C 2-3	C 2-3	C 2-3	C 2-3		
	$\lambda 45^\circ$	$\lambda 40^\circ$	$\lambda 45^\circ$		$\lambda 40^\circ$							$\lambda 27^\circ$					
		SHARK LINE															
	EX41	E382	E043	E620	E621	E550	E714	E710	E721	E711	E653	E712	E709	E720	E708	E243	
	1/8 - 1.1/2	1/8 - 1"	1/8 - 3/4	M3 - M16	M3 - M16	1/8 - 2"	1/8 - 1"	1/16 - 2"	1/8 - 1"	1/8 - 1.1/2	1/8 - 1"	1/16 - 1.1/4	1/8 - 3/4	1/8 - 3/4	1/8 - 1"	No.7 - No.36	
AMG	323	324	325	326	327	328	329	330	330	331	332	333	334	334	335	336	ISO
1.1	■25		■25	●7		●22	●4	●4	●4	●4	●25	●4	●4	●4	●4	●12	P 1
1.2	■22		■22	●6	●18	●20	●4	●4	●4	●4	●22	●4	●4	●4	●4	●10	P 1
1.3	■18		■18	●5	●14	●16	●6	●6	●6	●6	●18	●6	●6	●6	●6	●8	P 2
1.4	■16		■16	●4	●10	●12	■5	●5	■5	■5	●15	■5	■5	■5	■5	●6	P 3
1.5	■10	●7	■10	●3	●5	●7	●3	●3	●3	●3		●3	●3	●3	●3	●5	P 4
1.6			●5			●4											H 1
1.7																	H 3
1.8																	H 4
2.1	■7	■8	●7		●6	●7											M 1
2.2	■6	■7	●6		●4	●5											M 3
2.3	●4	■5	●4		●3	●7											M 2
2.4																	S 2
3.1				●12		■12	●6	●6	■6	●6		●6	●6	■6	●6	●14	K 1
3.2				●7		■7	●4	●4	■4	●4	●8	●4	●4	■4	●4	●8	K 2
3.3				●10		■10	●6	●6	■6	●6		●6	●6	■6	●6	●12	K 3
3.4				●5		■5	●4	●4	■4	●4		●4	●4	■4	●4		K 4
4.1																	S 1
4.2																	S 2
4.3																	S 3
5.1																	S 1
5.2					●4												S 2
5.3																	S 3
6.1			●4			■12											N 3
6.2			●10			●30	●11	●11	●11	●11	●30	●11	●11	●11	●11	●16	N 4
6.3			●7			●20					●20					●12	N 3
6.4			●2			●4											N 4
7.1				●10							●18						N 1
7.2				●12	●25	●35					●35					●20	N 1
7.3				●7	●13	●20	●11	●11	●11	●11		●11	●11	●11	●11	●12	N 1
7.4				●5	●10	●15	●7	●7	●7	●7		●7	●7	●7	●7		N 2
8.1							●4	●4	●4	●4	●30	●4	●4	●4	●4		O
8.2				●5		●12										●8	O
8.3				●3		●7											O
9.1																	H
10.1																	O

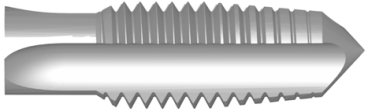

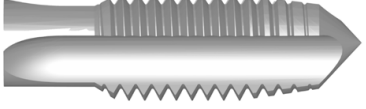
												
	L119	L126	L113	L114	L115	L000	L001	L002	L120	L110	L112	
	Set	Set	Set	Set	Set	Set	Set	Set	Set	16.00 - 4"	BT1 - No.7	
AMG	337	338	339	340	341	342	343	344	345	348	349	ISO
1.1												P 1
1.2												P 1
1.3												P 2
1.4												P 3
1.5												P 4
1.6												H 1
1.7												H 3
1.8												H 4
2.1												M 1
2.2												M 3
2.3												M 2
2.4												S 2
3.1												K 1
3.2												K 2
3.3												K 3
3.4												K 4
4.1												S 1
4.2												S 2
4.3												S 3
5.1												S 1
5.2												S 2
5.3												S 3
6.1												N 3
6.2												N 4
6.3												N 3
6.4												N 4
7.1												N 1
7.2												N 1
7.3												N 1
7.4												N 2
8.1												O
8.2												O
8.3												O
9.1												H
10.1												O

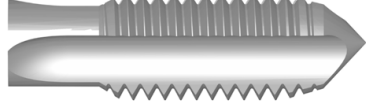
NO1 - NO9

NO1 =		A 6-8	
NO2 =		B 4-6	
NO3 =		C 2-3	

ISO
 NO6 = NO1 + NO2 + NO3
 NO7 = NO2 + NO3 *

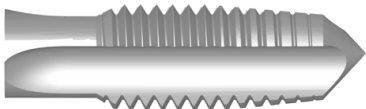
ANSI NO6 = NO1 (taper) + NO2 (plug) + NO3 (bottoming)

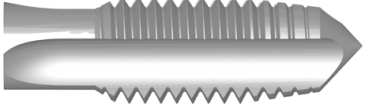
NO4 =		A 6-8	
NO5 =		B 3.5-5	

DIN
 ISO
 NO8 = NO3 + NO4 + NO5
 NO9 = NO3 + NO4

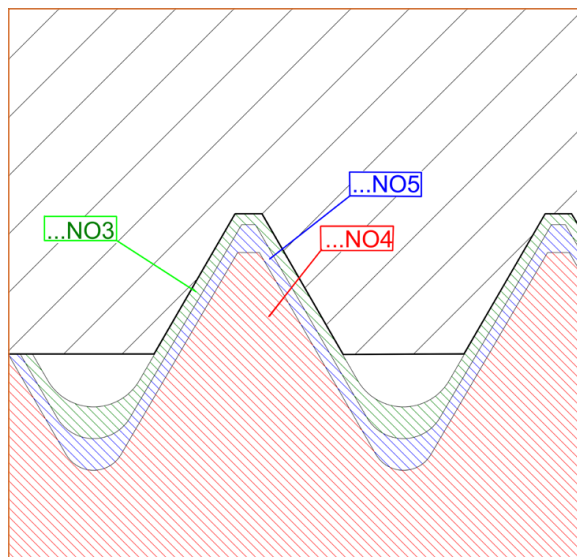

* E550
 E710 NO7 = NO3 (truncated) + NO3

- ## T200
- M Maschi a macchina Scanalature diritte
 - M Maschinen-Gewindebohrer, geradegenutet
 - M Machinetap met rechte spaangroeven
 - M Tarauds machine Goujures droites

- ## T201
- M Maschio a elica diritta, passaggio interno refrigerante
 - M Maschinen-Gewindebohrer, geradegenutet, Innenkühlung
 - M Machinetap met rechte spaangroeven, interne koeling
 - M Tarauds machine goujures droites, arrosage interne

- ## T210
- M Maschi a macchina Scanalature diritte
 - M Maschinen-Gewindebohrer, geradegenutet
 - M Machinetap met rechte spaangroeven
 - M Tarauds machine Goujures droites

T200	▪	1.7								
	•	1.8	3.1	3.2	6.4	7.4	8.2	8.3	10.1	
T201	▪	3.1	3.2	7.4	10.1					
	•	3.3	3.4	6.4	7.3	8.2	8.3			
T210	▪	1.8								
	•	1.7								

T200	M	DIN 371	6H		2XD	HM	C 2-3			TiCN	
T201	M	DIN 371 ≤ 10 376 ≥ 12	6HX		2.5XD	HM	C 2-3			Super B	
T210	M	DIN 371	6HX		2XD	HM	C 2-3			TiCN	

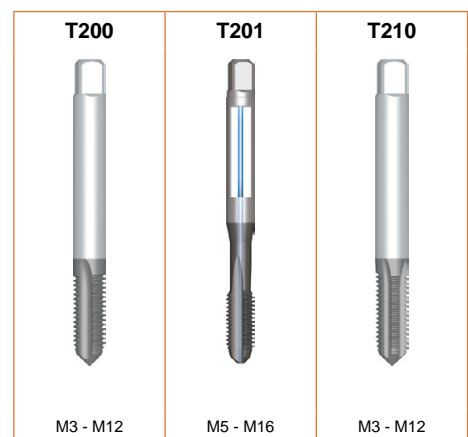
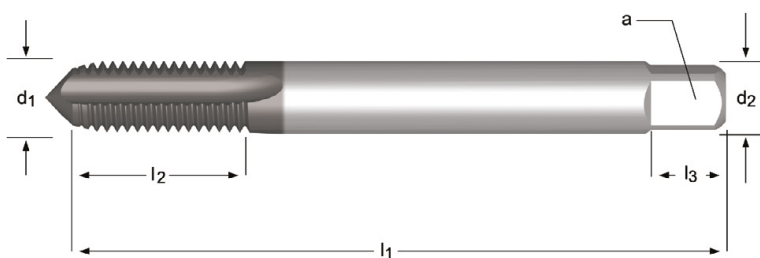

M	P mm	l ₁ mm	l ₂ mm	d ₂ Ø mm	□ a mm	l ₃ mm	z		l ₄ mm	T200	T201	T210
3	0.50	56	10	3.5	2.7	6	3	2.6	-	T200M3		
3	0.50	56	8	3.5	2.7	6	4	2.6	-			T210M3
4	0.70	63	11	4.5	3.4	6	5	3.4	-			T210M4
4	0.70	63	13	4.5	3.4	6	3	3.4	-	T200M4		
5	0.80	70	13.5	6.0	4.9	8	5	4.3	-			T210M5
5	0.80	70	16	6.0	4.9	8	3	4.3	-	T200M5		
5	0.80	70	16	6.0	4.9	8	4	4.3	-		T201M5	
6	1.00	80	16.5	6.0	4.9	8	5	5.1	-			T210M6
6	1.00	80	19	6.0	4.9	8	3	5.1	30	T200M6		
6	1.00	80	19	6.0	4.9	8	4	5.1	30		T201M6	
8	1.25	90	21.5	8.0	6.2	9	5	6.9	-			T210M8
8	1.25	90	22	8.0	6.2	9	3	6.9	35	T200M8		

M	P mm	l ₁ mm	l ₂ mm	d ₂ ∅ mm	□ a mm	l ₃ mm	z		l ₄ mm	T200	T201	T210
8	1.25	90	22	8.0	6.2	9	4	6.9	35		T201M8	
10	1.50	100	24	10.0	8.0	11	3	8.7	39	T200M10		
10	1.50	100	24	10.0	8.0	11	4	8.7	39		T201M10	
10	1.50	100	27	10.0	8.0	11	5	8.7				T210M10
12	1.75	110	23	9.0	7.0	10	3	10.4	-	T200M12		
12	1.75	110	23	9.0	7.0	10	4	10.4	-		T201M12	
12	1.75	110	32	12.0	9.0	12	6	10.4				T210M12
16	2.00	110	25	12.0	9.0	12	4	14.25	-		T201M16	

- ## T205
- M Maschi a macchina Scanalature elicoidali 15°
 - M Maschinen-Gewindebohrer, rechtsgedrahte Nuten 15°
 - M Machinetap met gespiraliseerde spaangroeven 15°
 - M Tarauds machine goujures hélicoïdales 15°

- ## T206
- M Maschi a macchina Scanalature elicoidali 15°, passaggio interno refrigerante
 - M Maschinen-Gewindebohrer, rechtsgedrahte Nuten 15°, Innenkühlung
 - M Machinetap met gespiraliseerde spaangroeven 15°, interne koeling
 - M Tarauds machine goujures hélicoïdales 15°, arrosage interne

T205; T206	▪	3.3	3.4	7.3	7.4
	•	3.1	3.2	8.2	8.3

T205	M	DIN 371 ≤ 10 376 ≥ 12	6H		2XD	HM	C 2-3				
T206	M	DIN 371 ≤ 10 376 ≥ 12	6H		2.5XD	HM	C 2-3				

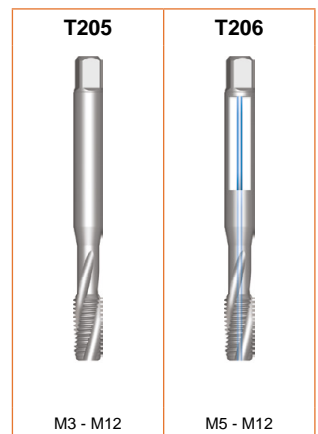
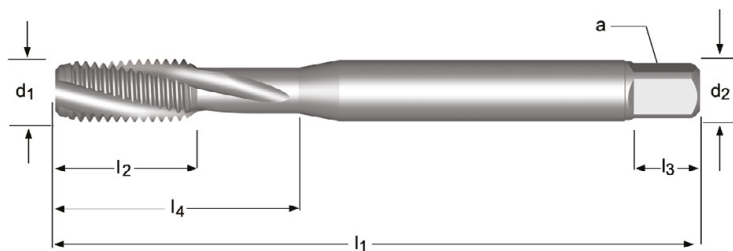

M	P mm	l ₁ mm	l ₂ mm	d ₂ ∅ mm	a mm	l ₃ mm	z		l ₄ mm	T205	T206
3	0.50	56	10	3.5	2.7	6	3	2.6	-	T205M3	
4	0.70	63	13	4.5	3.4	6	3	3.4	-	T205M4	
5	0.80	70	16	6.0	4.9	8	3	4.3	-	T205M5	T206M5
6	1.00	80	19	6.0	4.9	8	3	5.1	30	T205M6	T206M6
8	1.25	90	22	8.0	6.2	9	3	6.9	35	T205M8	T206M8
10	1.50	100	24	10.0	8.0	11	3	8.7	39	T205M10	T206M10
12	1.75	110	23	9.0	7.0	10	3	10.4	-	T205M12	T206M12

T215

- M Maschi a rullare
- M Maschinen-Gewindeformer
- M Machineroltap
- M Taraulds machine à refouler

T215 ■ 1.1 1.2 1.3 1.4 1.5 2.1 2.2 2.3 5.1 7.1 7.2 7.3
 • 2.4 5.2 6.1 6.3

T215 M DIN 2174 6HX 3XD HM C 2-3.5 TICN

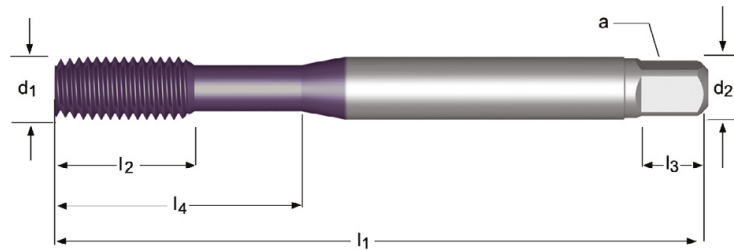

M	P mm	l ₁ mm	l ₂ mm	d ₂ ∅ mm	□ a mm	l ₃ mm	z		l ₄ mm	T215
3	0.50	56	10	3.5	2.7	6	4	2.8	-	T215M3
4	0.70	63	13	4.5	3.4	6	5	3.7	-	T215M4
5	0.80	70	16	6.0	4.9	8	5	4.6	-	T215M5
6	1.00	80	19	6.0	4.9	8	5	5.5	30	T215M6
8	1.25	90	22	8.0	6.2	9	5	7.4	35	T215M8
10	1.50	100	24	10.0	8.0	11	5	9.3	39	T215M10

- E100** • M Maschi a mano Scanalature diritte
E102 • M Handgewindebohrer, geradegenutet
E101 • M Handtap met rechte spaangroeven
 • M Tarauds à main Goujures droites

E100	•	1.1	1.2	1.3	1.4	1.5	3.1	3.2	3.3	3.4	6.1	6.2	6.3	6.4	7.2	7.3	7.4	8.2	8.3		
E102	•	1.1	1.2	1.3	1.4	1.5	2.1	2.2	2.3	3.1	3.2	3.3	3.4	4.1	4.2	4.3	5.1	5.2	5.3	6.1	6.2
		6.3	6.4	7.2	7.3	7.4	8.2	8.3													
E101	•	1.1	1.2	1.3	1.4	1.5	3.1	3.2	3.3	3.4	6.1	6.2	6.3	6.4	7.2	7.3	7.4	8.2	8.3		

E100	M	DIN 352	6H		1.5XD	HSS	C 2-3					
E102	M	DIN 352	6HX		1.5XD	HSS-E	C 2-3				ST	
E101	M	DIN 352	6H		1.5XD	HSS	C 2-3					

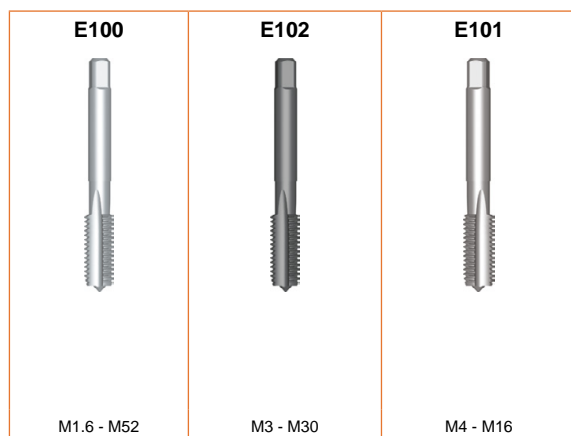
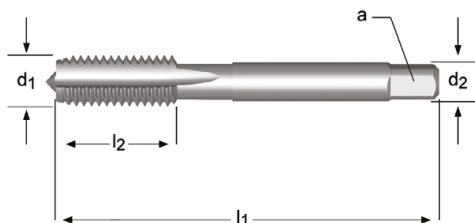

M	P mm	l ₁ mm	l ₂ mm	d ₂ Ø mm	□ a mm	z		E100	E102	E101
1.6	0.35	32	7	2.5	2.1	3	1.25	E100M1.6NO3		
1.6	0.35	32	7	2.5	2.1	3	1.25	E100M1.6NO8		
2	0.40	36	8	2.8	2.1	3	1.6	E100M2NO3	NO1 - NO9 	
2	0.40	36	8	2.8	2.1	3	1.6	E100M2NO8		
2.5	0.45	40	9	2.8	2.1	3	2.05	E100M2.5NO3		
2.5	0.45	40	9	2.8	2.1	3	2.05	E100M2.5NO8		
3	0.50	40	10	3.5	2.7	3	2.5	E100M3NO3		
3	0.50	40	10	3.5	2.7	3	2.5	E100M3NO8	E102M3NO8	¹⁾
3.5	0.60	45	10	4.0	3.0	3	2.9	E100M3.5NO3		
3.5	0.60	45	10	4.0	3.0	3	2.9	E100M3.5NO8		
4	0.70	45	12	4.5	3.4	3	3.3	E100M4NO3		E101M4NO3
4	0.70	45	12	4.5	3.4	3	3.3	E100M4NO8	E102M4NO8	¹⁾ E101M4NO8
5	0.80	50	14	6.0	4.9	3	4.2	E100M5NO3		E101M5NO3
5	0.80	50	14	6.0	4.9	3	4.2	E100M5NO8	E102M5NO8	¹⁾ E101M5NO8
6	1.00	56	16	6.0	4.9	3	5	E100M6NO3		E101M6NO3
6	1.00	56	16	6.0	4.9	3	5	E100M6NO8	E102M6NO8	¹⁾ E101M6NO8
7	1.00	56	16	6.0	4.9	3	6	E100M7NO3		
7	1.00	56	16	6.0	4.9	3	6	E100M7NO8		
8	1.25	63	19	6.0	4.9	3	6.8	E100M8NO3		E101M8NO3
8	1.25	63	19	6.0	4.9	3	6.8	E100M8NO8	E102M8NO8	¹⁾ E101M8NO8
9	1.25	63	20	7.0	5.5	3	7.8	E100M9NO3		
9	1.25	63	20	7.0	5.5	3	7.8	E100M9NO8		
10	1.50	70	22	7.0	5.5	3	8.5	E100M10NO3		E101M10NO3
10	1.50	70	22	7.0	5.5	3	8.5	E100M10NO8	E102M10NO8	¹⁾ E101M10NO8

¹⁾ NO4 con tratto cilindrico di centraggio / NO4 mit Führungsteil / NO4 met geleiding / NO4 avec un pilote de guidage

M	P mm	l ₁ mm	l ₂ mm	d ₂ Ø mm	□ a mm	z		E100	E102	E101
12	1.75	75	25	9.0	7.0	4	10.3	E100M12NO3		E101M12NO3
12	1.75	75	25	9.0	7.0	4	10.3	E100M12NO8	E102M12NO8 ¹⁾	E101M12NO8
14	2.00	80	25	11.0	9.0	4	12	E100M14NO3		E101M14NO3
14	2.00	80	25	11.0	9.0	4	12	E100M14NO8	E102M14NO8 ¹⁾	E101M14NO8
16	2.00	80	25	12.0	9.0	4	14	E100M16NO3		E101M16NO3
16	2.00	80	25	12.0	9.0	4	14	E100M16NO8	E102M16NO8 ¹⁾	E101M16NO8
18	2.50	95	32	14.0	11.0	4	15.5	E100M18NO3		
18	2.50	95	32	14.0	11.0	4	15.5	E100M18NO8	E102M18NO8 ¹⁾	
20	2.50	95	32	16.0	12.0	4	17.5	E100M20NO3		
20	2.50	95	32	16.0	12.0	4	17.5	E100M20NO8	E102M20NO8 ¹⁾	
22	2.50	100	34	18.0	14.5	4	19.5	E100M22NO3		
22	2.50	100	34	18.0	14.5	4	19.5	E100M22NO8		
24	3.00	110	38	18.0	14.5	4	21	E100M24NO3		
24	3.00	110	38	18.0	14.5	4	21	E100M24NO8	E102M24NO8 ¹⁾	
27	3.00	110	38	20.0	16.0	4	24	E100M27NO3		
27	3.00	110	38	20.0	16.0	4	24	E100M27NO8	E102M27NO8 ¹⁾	
30	3.50	125	45	22.0	18.0	4	26.5	E100M30NO3		
30	3.50	125	45	22.0	18.0	4	26.5	E100M30NO8	E102M30NO8 ¹⁾	
33	3.50	125	50	25.0	20.0	4	29.5	E100M33NO3		
33	3.50	125	50	25.0	20.0	4	29.5	E100M33NO8		
36	4.00	150	56	28.0	22.0	4	32	E100M36NO3		
36	4.00	150	56	28.0	22.0	4	32	E100M36NO8		
39	4.00	150	60	32.0	24.0	4	35	E100M39NO3		
39	4.00	150	60	32.0	24.0	4	35	E100M39NO8		
42	4.50	150	60	32.0	24.0	4	37.5	E100M42NO3		
42	4.50	150	60	32.0	24.0	4	37.5	E100M42NO8		
45	4.50	160	65	36.0	29.0	6	40.5	E100M45NO3		
45	4.50	160	65	36.0	29.0	6	40.5	E100M45NO8		
48	5.00	180	70	36.0	29.0	6	43	E100M48NO3		
48	5.00	180	70	36.0	29.0	6	43	E100M48NO8		
52	5.00	180	70	40.0	32.0	6	47	E100M52NO3		
52	5.00	180	70	40.0	32.0	6	47	E100M52NO8		

NO1 - NO9



219

¹⁾ NO4 con tratto cilindrico di centraggio / NO4 mit Führungsteil / NO4 met geleiding / NO4 avec un pilote de guidage



- E200** • M Maschi a macchina Scanalature diritte Fornito in HSS-E fino a nuovo stock
- E250** • M Maschinen-Gewindebohrer, geradegenutet Lieferung in HSS-E bis neuer Lagerbestand verfügbar ist
- E237** • M Hand-/machinetap met rechte spaangroeven Geleverd in HSS-E tot de nieuwe voorraad beschikbaar is
- E251** • M Tarauds machine Goujures droites Fourni en HSS-E jusqu'à ce que le nouveau stock soit disponible

E200; E250; E237; E251 • 1.1 1.2 1.3 1.4 1.5 3.1 3.2 3.3 6.2 6.3 7.2 7.3 8.2

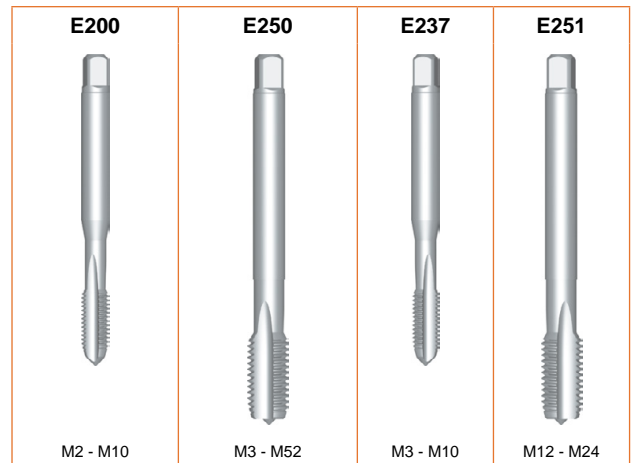
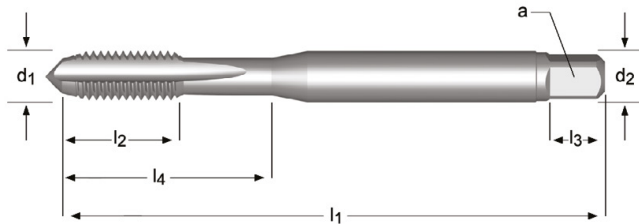
E200	M	DIN 371	6H		1.5XD	HSS-E PM	A 6-8 C 2-3				
E250	M	DIN 376	6H		1.5XD	HSS-E PM	A 6-8 C 2-3				
E237	M	DIN 371	6H		1.5XD	HSS-E PM	C 2-3				
E251	M	DIN 376	6H		1.5XD	HSS-E PM	C 2-3				



M	P mm	l ₁ mm	l ₂ mm	d ₂ ∅ mm	a mm	l ₃ mm	z		l ₄ mm	E200	E250	E237	E251
2	0.40	45	6	2.8	2.1	5	3	1.6	9	E200M2			
2.5	0.45	50	8	2.8	2.1	5	3	2.05	12.5	E200M2.5			
3	0.50	56	10	2.2	2.1	5	3	2.5			E250M3		
3	0.50	56	9	3.5	2.7	6	3	2.5	18	E200M3		E237M3	
3	0.50	56	9	3.5	2.7	6	3	2.5	18	E200M3NO1			
4	0.70	63	12	2.8	2.1	5	3	3.3			E250M4		
4	0.70	63	12	4.5	3.4	6	3	3.3	21	E200M4		E237M4	
4	0.70	63	12	4.5	3.4	6	3	3.3	21	E200M4NO1			
5	0.80	70	13	3.5	2.7	6	3	4.2			E250M5		
5	0.80	70	13	6.0	4.9	8	3	4.2	25	E200M5		E237M5	
5	0.80	70	13	6.0	4.9	8	3	4.2	25	E200M5NO1			
6	1.00	80	15	4.5	3.4	6	3	5.0			E250M6		
6	1.00	80	15	6.0	4.9	8	3	5	30	E200M6		E237M6	
6	1.00	80	15	4.5	3.4	6	3	5.0			E250M6NO1		
6	1.00	80	15	6.0	4.9	8	3	5	30	E200M6NO1			
8	1.25	90	18	6.0	4.9	8	3	6.8			E250M8		
8	1.25	90	18	8.0	6.2	9	3	6.8	35	E200M8		E237M8	
8	1.25	90	18	6.0	4.9	8	3	6.8			E250M8NO1		
8	1.25	90	18	8.0	6.2	9	3	6.8	35	E200M8NO1			
10	1.50	100	20	10.0	8.0	11	3	8.5	39	E200M10		E237M10	
10	1.50	100	20	7.0	5.5	8	3	8.5			E250M10		
10	1.50	100	20	10.0	8.0	11	3	8.5	39	E200M10NO1			
12	1.75	110	23	9.0	7.0	10	3	10.3			E250M12		
12	1.75	110	23	9.0	7.0	10	4	10.3					E251M12

M	P mm	l ₁ mm	l ₂ mm	d ₂ ∅ mm	□ a mm	l ₃ mm	z		l ₄ mm	E200	E250	E237	E251
12	1.75	110	23	9.0	7.0	10	3	10.3			E250M12NO1		
14	2.00	110	25	11.0	9.0	12	3	12.0			E250M14		
14	2.00	110	25	11.0	9.0	12	4	12.0					E251M14
14	2.00	110	25	11.0	9.0	12	3	12.0			E250M14NO1		
16	2.00	110	25	12.0	9.0	12	3	14.0			E250M16		
16	2.00	110	25	12.0	9.0	12	4	14.0					E251M16
16	2.00	110	25	12.0	9.0	12	3	14.0			E250M16NO1		
18	2.50	125	30	14.0	11.0	14	3	15.5			E250M18	 NO1 - NO9 219	
18	2.50	125	30	14.0	11.0	14	4	15.5					E251M18
18	2.50	125	30	14.0	11.0	14	3	15.5			E250M18NO1		
20	2.50	140	30	16.0	12.0	15	3	17.5			E250M20		
20	2.50	140	30	16.0	12.0	15	4	17.5					E251M20
20	2.50	140	30	16.0	12.0	15	3	17.5			E250M20NO1		
22	2.50	140	34	18.0	14.5	17	4	19.5			E250M22		E251M22
22	2.50	140	34	18.0	14.5	17	4	19.5			E250M22NO1		
24	3.00	160	38	18.0	14.5	17	4	21.0			E250M24		E251M24
27	3.00	160	38	20.0	16.0	19	4	24.0			E250M27		
30	3.50	180	45	22.0	18.0	21	4	26.5			E250M30		
33	3.50	180	50	25.0	20.0	23	4	29.5			E250M33		
36	4.00	200	55	28.0	22.0	25	4	32.0			E250M36		
39	4.00	200	60	32.0	24.0	27	4	35.0			E250M39		
42	4.50	200	60	32.0	24.0	27	4	37.5			E250M42	¹⁾	
45	4.50	220	65	36.0	29.0	32	6	40.5			E250M45	¹⁾	
48	5.00	250	70	36.0	29.0	32	6	43.0			E250M48	¹⁾	
52	5.00	250	70	40.0	32.0	35	6	47.0			E250M52	¹⁾	

- E201** • M Maschi a macchina Scanalature diritte , White Shark
- E252** • M Maschinen-Gewindebohrer, geradegenutet, Weissring Shark
- E390** • M Tarauds machine Goujures droites , Shark bague blanche

Fornito in HSS-E fino a nuovo stock

Lieferung in HSS-E bis neuer Lagerbestand verfügbar ist

Geleverd in HSS-E tot de nieuwe voorraad beschikbaar is

Fourni en HSS-E jusqu'à ce que le nouveau stock soit disponible

E201; E252; E390	▪	3.1	3.2	3.3	8.2
	•	3.4	6.2	6.4	7.4

E201	M	DIN 371	6HX		2XD	HSS-E PM	C 2-3			ST
E252	M	DIN 376	6HX		2XD	HSS-E PM	C 2-3			ST
E390	M	DIN 371 ≤ 10 376 >math>\geq 12</math>	6HX		2XD	HSS-E PM	C 2-3			TiAIN

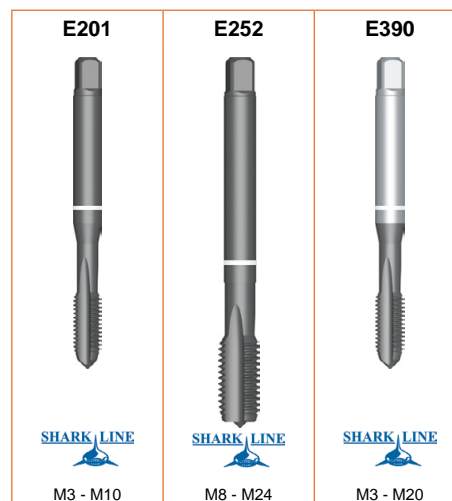
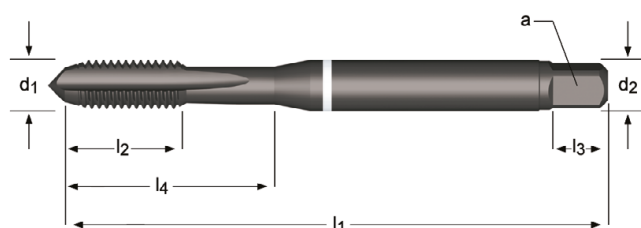

M	P mm	l ₁ mm	l ₂ mm	d ₂ ∅ mm	a mm	l ₃ mm	z		l ₄ mm	E201	E252	E390
3	0.50	56	9	3.5	2.7	6	3	2.5	18	E201M3		E390M3
4	0.70	63	12	4.5	3.4	6	4	3.3	21	E201M4		E390M4
5	0.80	70	13	6.0	4.9	8	4	4.2	25	E201M5		E390M5
6	1.00	80	15	6.0	4.9	8	4	5.0	30	E201M6		E390M6
8	1.25	90	18	6.0	4.9	8	4	6.8			E252M8	
8	1.25	90	18	8.0	6.2	9	4	6.8	35	E201M8		E390M8
10	1.50	100	20	10.0	8.0	11	4	8.5	39	E201M10		E390M10
10	1.50	100	20	7.0	5.5	8	4	8.5			E252M10	
12	1.75	110	23	9.0	7.0	10	4	10.3			E252M12	E390M12
14	2.00	110	25	11.0	9.0	12	4	12.0			E252M14	
16	2.00	110	25	12.0	9.0	12	4	14.0			E252M16	E390M16
18	2.50	125	30	14.0	11.0	14	4	15.5			E252M18	
20	2.50	140	30	16.0	12.0	15	4	17.5			E252M20	E390M20
22	2.50	140	34	18.0	14.5	17	4	19.5			E252M22	
24	3.00	160	38	18.0	14.5	17	4	21.0			E252M24	

- E500** • M Maschi a macchina Scanalature diritte
E501 • M Maschinen-Gewindebohrer, geradegenutet
E504 • M Hand-/machinetap met rechte spaangroeven
 • M Tarauds machine Goujures droites

E500; E501	•	1.1	1.2	1.3	1.4	1.5	3.1	3.2	3.3	3.4	6.1	6.2	6.3	6.4	7.2	7.3	7.4	8.2	8.3	
E504	▪	3.1	3.2	3.3																
	•	1.1	1.2	1.3	1.4	1.5	3.4	6.2	6.3	6.4	7.2	7.3	7.4	8.2	8.3					

E500	M	ISO 529	6H		1.5XD	HSS							
E501	M	ISO 529	6H		1.5XD	HSS							
E504	M	ISO 529	6H		1.5XD	HSS							

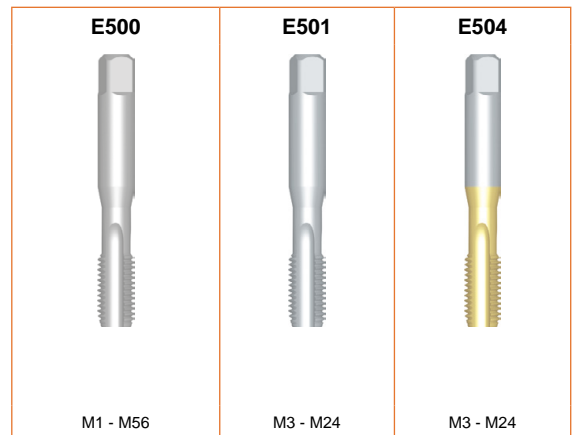
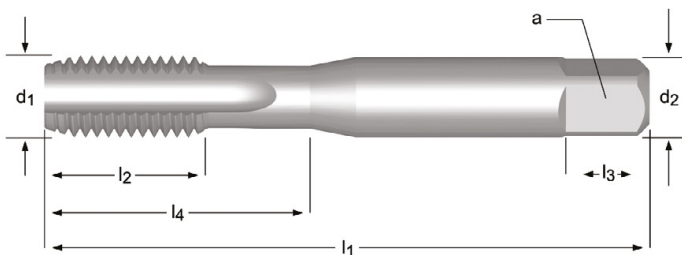



M	P mm	l ₁ mm	l ₂ mm	d ₂ Ø mm	∅ a mm	l ₃ mm	z		l ₄ mm	E500	E501	E504
1	0.25	38	4.5	2.50	2.00	4	2	0.75	4.5	E500M1NO1	¹⁾	
1	0.25	38	4.5	2.50	2.00	4	2	0.75	4.5	E500M1NO2	¹⁾	
1	0.25	38	4.5	2.50	2.00	4	2	0.75	4.5	E500M1NO3	¹⁾	
1.2	0.25	38	4.5	2.50	2.00	4	2	0.95	4.5	E500M1.2NO1	¹⁾	
1.2	0.25	38	4.5	2.50	2.00	4	2	0.95	4.5	E500M1.2NO2	¹⁾	
1.2	0.25	38	4.5	2.50	2.00	4	2	0.95	4.5	E500M1.2NO3	¹⁾	
1.4	0.30	40	6	2.50	2.00	4	2	1.1	6	E500M1.4NO1	¹⁾	
1.4	0.30	40	6	2.50	2.00	4	2	1.1	6	E500M1.4NO2	¹⁾	
1.4	0.30	40	6	2.50	2.00	4	2	1.1	6	E500M1.4NO3	¹⁾	
1.6	0.35	41	8	2.50	2.00	4	2	1.25	8	E500M1.6NO1		
1.6	0.35	41	8	2.50	2.00	4	2	1.25	8	E500M1.6NO2		
1.6	0.35	41	8	2.50	2.00	4	2	1.25	8	E500M1.6NO3	NO1 - NO9	
1.6	0.35	41	8	2.50	2.00	4	2	1.25	8	E500M1.6NO6		
1.7	0.35	41	8	2.50	2.00	4	2	1.35	8	E500M1.7NO1		
1.7	0.35	41	8	2.50	2.00	4	2	1.35	8	E500M1.7NO2		
1.7	0.35	41	8	2.50	2.00	4	2	1.35	8	E500M1.7NO3		
1.7	0.35	41	8	2.50	2.00	4	2	1.35	8	E500M1.7NO6		
1.7	0.35	41	8	2.50	2.00	4	2	1.35	8	E500M1.7NO8		

¹⁾ 5H

M	P mm	l ₁ mm	l ₂ mm	d ₂ ∅ mm	∠ a mm	l ₃ mm	z		l ₄ mm	E500	E501	E504
1.8	0.35	41	8	2.50	2.00	4	2	1.45	8	E500M1.8NO1		
1.8	0.35	41	8	2.50	2.00	4	2	1.45	8	E500M1.8NO2		
1.8	0.35	41	8	2.50	2.00	4	2	1.45	8	E500M1.8NO3		
2	0.40	41	8	2.50	2.00	4	3	1.6	8	E500M2NO1		
2	0.45	41	8	2.50	2.00	4	3	1.55	8	E500M2X.45NO1		
2	0.40	41	8	2.50	2.00	4	3	1.6	8	E500M2NO2		
2	0.45	41	8	2.50	2.00	4	3	1.55	8	E500M2X.45NO2		
2	0.40	41	8	2.50	2.00	4	3	1.6	8	E500M2NO3		
2	0.45	41	8	2.50	2.00	4	3	1.55	8	E500M2X.45NO3		
2	0.40	41	8	2.50	2.00	4	3	1.6	8	E500M2NO6		
2	0.40	41	8	2.50	2.00	4	3	1.6	8	E500M2NO8		
2.2	0.45	44.5	9.5	2.80	2.24	5	3	1.75	9.5	E500M2.2NO1		
2.2	0.45	44.5	9.5	2.80	2.24	5	3	1.75	9.5	E500M2.2NO2		
2.2	0.45	44.5	9.5	2.80	2.24	5	3	1.75	9.5	E500M2.2NO3		
2.3	0.45	44.5	9.5	2.80	2.24	5	3	1.85	9.5	E500M2.3NO1		
2.3	0.45	44.5	9.5	2.80	2.24	5	3	1.85	9.5	E500M2.3NO2		
2.3	0.45	44.5	9.5	2.80	2.24	5	3	1.85	9.5	E500M2.3NO3		
2.5	0.45	44.5	9.5	2.80	2.24	5	3	2.05	9.5	E500M2.5NO1		
2.5	0.45	44.5	9.5	2.80	2.24	5	3	2.05	9.5	E500M2.5NO2		
2.5	0.45	44.5	9.5	2.80	2.24	5	3	2.05	9.5	E500M2.5NO3		
2.5	0.45	44.5	9.5	2.80	2.24	5	3	2.05	9.5	E500M2.5NO6		
2.5	0.45	44.5	9.5	2.80	2.24	5	3	2.05	9.5	E500M2.5NO8		
2.6	0.45	44.5	9.5	2.80	2.24	5	3	2.15	9.5	E500M2.6NO1		
2.6	0.45	44.5	9.5	2.80	2.24	5	3	2.15	9.5	E500M2.6NO2		
2.6	0.45	44.5	9.5	2.80	2.24	5	3	2.15	9.5	E500M2.6NO3		
3	0.50	48	12.5	3.15	2.50	5	3	2.5	12.5	E500M3NO1	E501M3NO1	
3	0.60	48	12.5	3.15	2.50	5	3	2.4	12.5	E500M3X.6NO1		
3	0.50	48	12.5	3.15	2.50	5	3	2.5	12.5	E500M3NO2	E501M3NO2	
3	0.60	48	12.5	3.15	2.50	5	3	2.4	12.5	E500M3X.6NO2		
3	0.50	48	12.5	3.15	2.50	5	3	2.5	12.5	E500M3NO3	E501M3NO3	E504M3NO3
3	0.60	48	12.5	3.15	2.50	5	3	2.4	12.5	E500M3X.6NO3		
3	0.50	48	12.5	3.15	2.50	5	3	2.5	12.5	E500M3NO6		
3	0.50	48	12.5	3.15	2.50	5	3	2.5	12.5	E500M3NO7		
3	0.50	48	12.5	3.15	2.50	5	3	2.5	12.5	E500M3NO8		
3.5	0.60	50	14	3.55	2.80	5	3	2.9	14	E500M3.5NO1		
3.5	0.60	50	14	3.55	2.80	5	3	2.9	14	E500M3.5NO2		
3.5	0.60	50	14	3.55	2.80	5	3	2.9	14	E500M3.5NO3		
3.5	0.60	50	14	3.55	2.80	5	3	2.9	14	E500M3.5NO6		
4	0.70	53	14	4.00	3.15	6	3	3.3	14	E500M4NO1	E501M4NO1	
4	0.75	53	14	4.00	3.15	6	3	3.25	14	E500M4X.75NO1		
4	0.70	53	14	4.00	3.15	6	3	3.3	14	E500M4NO2	E501M4NO2	
4	0.75	53	14	4.00	3.15	6	3	3.25	14	E500M4X.75NO2		
4	0.70	53	14	4.00	3.15	6	3	3.3	14	E500M4NO3	E501M4NO3	E504M4NO3
4	0.75	53	14	4.00	3.15	6	3	3.25	14	E500M4X.75NO3		
4	0.70	53	14	4.00	3.15	6	3	3.3	14	E500M4NO6		
4	0.70	53	14	4.00	3.15	6	3	3.3	14	E500M4NO7		
4	0.70	53	14	4.00	3.15	6	3	3.3	14	E500M4NO8		
4.5	0.75	53	9.5	4.50	3.55	6	3	3.8	18	E500M4.5NO1		
4.5	0.75	53	9.5	4.50	3.55	6	3	3.8	18	E500M4.5NO2		
4.5	0.75	53	9.5	4.50	3.55	6	3	3.8	18	E500M4.5NO3		
4.5	0.75	53	9.5	4.50	3.55	6	3	3.8	18	E500M4.5NO6		
5	0.80	58	11	5.00	4.00	7	3	4.2	22	E500M5NO1		
5	0.90	58	11	5.00	4.00	7	3	4.1	22	E500M5X.9NO1		
5	0.80	58	11	5.00	4.00	7	3	4.2	22	E500M5NO2	E501M5NO2	
5	0.90	58	11	5.00	4.00	7	3	4.1	22	E500M5X.9NO2		
5	0.80	58	11	5.00	4.00	7	3	4.2	22	E500M5NO3	E501M5NO3	E504M5NO3
5	0.90	58	11	5.00	4.00	7	3	4.1	22	E500M5X.9NO3		
5	0.80	58	11	5.00	4.00	7	3	4.2	22	E500M5NO6		
5	0.80	58	11	5.00	4.00	7	3	4.2	22	E500M5NO7		
5	0.80	58	11	5.00	4.00	7	3	4.2	22	E500M5NO8		
5.5	0.90	62	12	5.60	4.50	7	3	4.6	21	E500M5.5X.9NO1		
5.5	0.90	62	12	5.60	4.50	7	3	4.6	21	E500M5.5X.9NO2		
5.5	0.90	62	12	5.60	4.50	7	3	4.6	21	E500M5.5X.9NO3		
6	1.00	66	13	6.30	5.00	8	3	5	26	E500M6NO1	E501M6NO1	
6	1.00	66	13	6.30	5.00	8	3	5	26	E500M6NO2	E501M6NO2	
6	1.00	66	13	6.30	5.00	8	3	5	26	E500M6NO3	E501M6NO3	E504M6NO3
6	1.00	66	13	6.30	5.00	8	3	5	26	E500M6NO6		
6	1.00	66	13	6.30	5.00	8	3	5	26	E500M6NO7		
6	1.00	66	13	6.30	5.00	8	3	5	26	E500M6NO8		
7	1.00	66	13	7.10	5.60	8	3	6	26	E500M7NO1		



M	P mm	l ₁ mm	l ₂ mm	d ₂ ∅ mm	∅ a mm	l ₃ mm	z		l ₄ mm	E500	E501	E504
7	1.00	66	13	7.10	5.60	8	3	6	26	E500M7NO2		
7	1.00	66	13	7.10	5.60	8	3	6	26	E500M7NO3		
7	1.00	66	13	7.10	5.60	8	3	6	26	E500M7NO6		
8	1.25	72	16	8.00	6.30	9	3	6.8	29	E500M8NO1	E501M8NO1	
8	1.25	72	16	8.00	6.30	9	3	6.8	29	E500M8NO2	E501M8NO2	
8	1.25	72	16	8.00	6.30	9	3	6.8	29	E500M8NO3	E501M8NO3	E504M8NO3
8	1.25	72	16	8.00	6.30	9	3	6.8	29	E500M8NO6		
8	1.25	72	16	8.00	6.30	9	3	6.8	29	E500M8NO7		
8	1.25	72	16	8.00	6.30	9	3	6.8	29	E500M8NO8		
9	1.25	72	16	9.00	7.10	10	3	7.8	29	E500M9NO1		
9	1.25	72	16	9.00	7.10	10	3	7.8	29	E500M9NO2		
9	1.25	72	16	9.00	7.10	10	3	7.8	29	E500M9NO3		
9	1.25	72	16	9.00	7.10	10	3	7.8	29	E500M9NO6		
10	1.50	80	18	10.00	8.00	11	3	8.5	34	E500M10NO1	E501M10NO1	
10	1.50	80	18	10.00	8.00	11	3	8.5	34	E500M10NO2	E501M10NO2	
10	1.50	80	18	10.00	8.00	11	3	8.5	34	E500M10NO3	E501M10NO3	E504M10NO3
10	1.50	80	18	10.00	8.00	11	3	8.5	34	E500M10NO6		
10	1.50	80	18	10.00	8.00	11	3	8.5	34	E500M10NO7		
10	1.50	80	18	10.00	8.00	11	3	8.5	34	E500M10NO8		
11	1.50	85	19	8.00	6.30	9	3	9.5	-	E500M11NO1	 219	
11	1.50	85	19	8.00	6.30	9	3	9.5	-	E500M11NO2		
11	1.50	85	19	8.00	6.30	9	3	9.5	-	E500M11NO3		
11	1.50	85	19	8.00	6.30	9	3	9.5	-	E500M11NO6		
12	1.75	89	22	9.00	7.10	10	3	10.3	-	E500M12NO1	E501M12NO1	
12	1.75	89	22	9.00	7.10	10	3	10.3	-	E500M12NO2	E501M12NO2	
12	1.75	89	22	9.00	7.10	10	3	10.3	-	E500M12NO3	E501M12NO3	
12	1.75	89	22	9.00	7.10	10	3	10.3	-	E500M12NO6		
12	1.75	89	22	9.00	7.10	10	3	10.3	-	E500M12NO7		
12	1.75	89	22	9.00	7.10	10	3	10.3	-	E500M12NO8		
14	2.00	95	24	11.20	9.00	12	4	12	-	E500M14NO1	E501M14NO1	
14	2.00	95	24	11.20	9.00	12	4	12	-	E500M14NO2	E501M14NO2	
14	2.00	95	24	11.20	9.00	12	4	12	-	E500M14NO3	E501M14NO3	
14	2.00	95	24	11.20	9.00	12	4	12	-	E500M14NO6		
14	2.00	95	24	11.20	9.00	12	4	12	-	E500M14NO7		
14	2.00	95	24	11.20	9.00	12	4	12	-	E500M14NO8		
16	2.00	102	24	12.50	10.00	13	4	14	-	E500M16NO1	E501M16NO1	
16	2.00	102	24	12.50	10.00	13	4	14	-	E500M16NO2	E501M16NO2	
16	2.00	102	24	12.50	10.00	13	4	14	-	E500M16NO3	E501M16NO3	
16	2.00	102	24	12.50	10.00	13	4	14	-	E500M16NO6		
16	2.00	102	24	12.50	10.00	13	4	14	-	E500M16NO7		
16	2.00	102	24	12.50	10.00	13	4	14	-	E500M16NO8		
18	2.50	112	29	14.00	11.20	14	4	15.5	-	E500M18NO1		
18	2.50	112	29	14.00	11.20	14	4	15.5	-	E500M18NO2		
18	2.50	112	29	14.00	11.20	14	4	15.5	-	E500M18NO3	E501M18NO3	
18	2.50	112	29	14.00	11.20	14	4	15.5	-	E500M18NO6		
20	2.50	112	29	14.00	11.20	14	4	17.5	-	E500M20NO1	E501M20NO1	
20	2.50	112	29	14.00	11.20	14	4	17.5	-	E500M20NO2	E501M20NO2	
20	2.50	112	29	14.00	11.20	14	4	17.5	-	E500M20NO3	E501M20NO3	
20	2.50	112	29	14.00	11.20	14	4	17.5	-	E500M20NO6		
20	2.50	112	29	14.00	11.20	14	4	17.5	-	E500M20NO7		
20	2.50	112	29	14.00	11.20	14	4	17.5	-	E500M20NO8		
22	2.50	118	29	16.00	12.50	16	4	19.5	-	E500M22NO1		
22	2.50	118	29	16.00	12.50	16	4	19.5	-	E500M22NO2		
22	2.50	118	29	16.00	12.50	16	4	19.5	-	E500M22NO3	E501M22NO3	
22	2.50	118	29	16.00	12.50	16	4	19.5	-	E500M22NO6		
24	3.00	130	35	18.00	14.00	18	4	21	-	E500M24NO1		
24	3.00	130	35	18.00	14.00	18	4	21	-	E500M24NO2	E501M24NO2	
24	3.00	130	35	18.00	14.00	18	4	21	-	E500M24NO3	E501M24NO3	
24	3.00	130	35	18.00	14.00	18	4	21	-	E500M24NO6		
24	3.00	130	35	18.00	14.00	18	4	21	-	E500M24NO7		
27	3.00	135	35	20.00	16.00	20	4	24	-	E500M27NO1		
27	3.00	135	35	20.00	16.00	20	4	24	-	E500M27NO2		
27	3.00	135	35	20.00	16.00	20	4	24	-	E500M27NO3		
30	3.50	138	41	20.00	16.00	20	4	26.5	-	E500M30NO1		
30	3.50	138	41	20.00	16.00	20	4	26.5	-	E500M30NO2		
30	3.50	138	41	20.00	16.00	20	4	26.5	-	E500M30NO3		
33	3.50	151	41	22.40	18.00	22	4	29.5	-	E500M33NO1		
33	3.50	151	41	22.40	18.00	22	4	29.5	-	E500M33NO2		
33	3.50	151	41	22.40	18.00	22	4	29.5	-	E500M33NO3		
36	4.00	162	47	25.00	20.00	24	4	32	-	E500M36NO1		

M	P mm	l ₁ mm	l ₂ mm	d ₂ ∅ mm	∠ a mm	l ₃ mm	z		l ₄ mm	E500	E501	E504
36	4.00	162	47	25.00	20.00	24	4	32	-	E500M36NO2		
36	4.00	162	47	25.00	20.00	24	4	32	-	E500M36NO3		
39	4.00	170	47	28.00	22.40	26	4	35	-	E500M39NO1		
39	4.00	170	47	28.00	22.40	26	4	35	-	E500M39NO2		
39	4.00	170	47	28.00	22.40	26	4	35	-	E500M39NO3		
42	4.50	170	53	28.00	22.40	26	6	37.5	-	E500M42NO1		
42	4.50	170	53	28.00	22.40	26	6	37.5	-	E500M42NO2		
42	4.50	170	53	28.00	22.40	26	6	37.5	-	E500M42NO3		
45	4.50	187	54	31.50	25.00	28	6	40.5	-	E500M45NO1		
45	4.50	187	54	31.50	25.00	28	6	40.5	-	E500M45NO2		
45	4.50	187	54	31.50	25.00	28	6	40.5	-	E500M45NO3		
48	5.00	187	60	31.50	25.00	28	6	43	-	E500M48NO1		
48	5.00	187	60	31.50	25.00	28	6	43	-	E500M48NO2		
48	5.00	187	60	31.50	25.00	28	6	43	-	E500M48NO3		
52	5.00	200	60	35.50	28.00	31	6	47	-	E500M52NO3		
56	5.50	200	60	35.50	28.00	31	6	50.5	-	E500M56NO3		

N01 - N09



219

E303

- M Maschi a macchina Scanalature diritte
- M Maschinen-Gewindebohrer, geradegenutet
- M Machinetap met rechte spaangroeven
- M Tarauds machine Goujures droites

E303 • 1.1 1.2 1.3 1.4 1.5 3.1 3.2 3.3 6.2 6.3 7.2 7.3 8.2

E303 M DIN 357 6H 2XD HSS-E D18-20 C 2-3

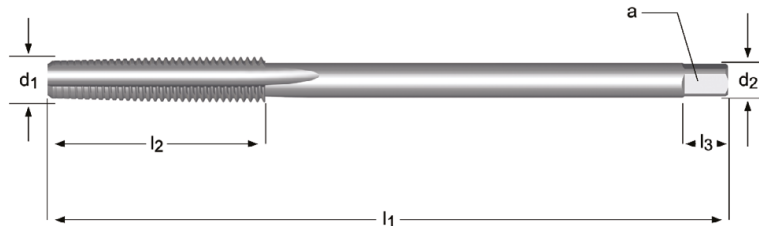

M	P mm	l ₁ mm	l ₂ mm	d ₂ Ø mm	∠ a mm	l ₃ mm	z	↔	E303
3	0.50	70	22	2.2	2.1	5	3	2.5	E303M3NO1
3	0.50	70	22	2.2	2.1	5	3	2.5	E303M3NO3
4	0.70	90	25	2.8	2.1	5	3	3.3	E303M4NO1
4	0.70	90	25	2.8	2.1	5	3	3.3	E303M4NO3
5	0.80	100	28	3.5	2.7	6	3	4.2	E303M5NO1
5	0.80	100	28	3.5	2.7	6	3	4.2	E303M5NO3
6	1.00	110	32	4.5	3.4	6	3	5.0	E303M6NO1
6	1.00	110	32	4.5	3.4	6	3	5.0	E303M6NO3
8	1.25	125	40	6.0	4.9	8	3	6.8	E303M8NO1
8	1.25	125	40	6.0	4.9	8	3	6.8	E303M8NO3
10	1.50	140	45	7.0	5.5	8	3	8.5	E303M10NO1
10	1.50	140	45	7.0	5.5	8	3	8.5	E303M10NO3
12	1.75	180	50	9.0	7.0	10	3	10.3	E303M12NO1
12	1.75	180	50	9.0	7.0	10	3	10.3	E303M12NO3
14	2.00	200	56	11.0	9.0	12	3	12.0	E303M14NO1
14	2.00	200	56	11.0	9.0	12	3	12.0	E303M14NO3
16	2.00	200	63	12.0	9.0	12	3	14.0	E303M16NO1
16	2.00	200	63	12.0	9.0	12	3	14.0	E303M16NO3
20	2.50	250	70	16.0	12.0	15	3	17.5	E303M20NO1
20	2.50	250	70	16.0	12.0	15	3	17.5	E303M20NO3

NO1 - NO9
219

E600

- M Maschi a macchina, extra lungo Scanalature diritte
- M Maschinen-Gewindebohrer, extra lang, geradegenutet

E610

- M Machinetap, extra lang met rechte spaangroeven
- M Tarauds machine, Extra Long Goujures droites

Fornito in HSS-E fino a nuovo stock

Lieferung in HSS-E bis neuer Lagerbestand verfügbar ist

Geleverd in HSS-E tot de nieuwe voorraad beschikbaar is

Fourni en HSS-E jusqu'à ce que le nouveau stock soit disponible

E600	•	1.1	1.2	1.3	1.4	1.5	3.1	3.2	3.3	3.4	6.1	6.2	6.3	6.4	7.2	7.3	7.4	8.2	8.3
E610	▪	3.1	3.2	3.3															
	•	1.1	1.2	1.3	1.4	1.5	3.4	6.2	6.3	6.4	7.2	7.3	7.4	8.2	8.3				

E600	M	ISO 2283	6H		1.5XD	HSS-E PM	C 2-3				
E610	M	ISO 2283	6H		1.5XD	HSS-E PM	C 2-3			TIN	

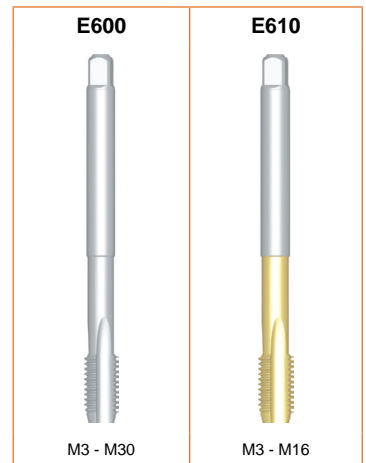
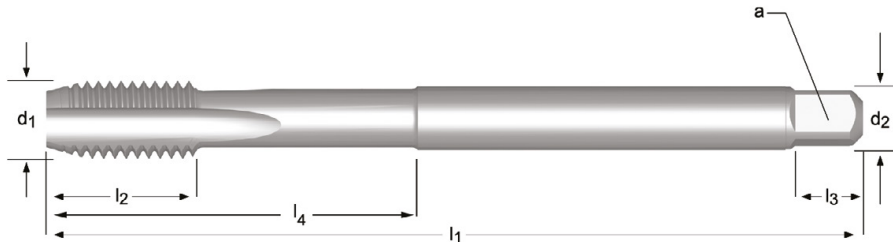

M	P mm	l ₁ mm	l ₂ mm	d ₂ Ø mm	∠ a mm	l ₃ mm	z		l ₄ mm	E600	E610
3	0.50	66	9	3.15	2.50	5	3	2.5	18	E600M3NO3	E610M3NO3
4	0.70	73	12	3.15	2.50	5	3	3.3	-	E600M4NO1	
4	0.70	73	12	3.15	2.50	5	3	3.3	-	E600M4NO2	
4	0.70	73	12	3.15	2.50	5	3	3.3	-	E600M4NO3	E610M4NO3
5	0.80	79	12	4.00	3.15	6	3	4.2	-	E600M5NO1	
5	0.80	79	12	4.00	3.15	6	3	4.2	-	E600M5NO2	
5	0.80	79	12	4.00	3.15	6	3	4.2	-	E600M5NO3	E610M5NO3
6	1.00	89	14	4.50	3.55	6	3	5	-	E600M6NO1	
6	1.00	89	14	4.50	3.55	6	3	5	-	E600M6NO2	
6	1.00	89	14	4.50	3.55	6	3	5	-	E600M6NO3	E610M6NO3
8	1.25	97	17	6.30	5.00	8	3	6.8	-	E600M8NO1	
8	1.25	97	17	6.30	5.00	8	3	6.8	-	E600M8NO2	
8	1.25	97	17	6.30	5.00	8	3	6.8	-	E600M8NO3	E610M8NO3
10	1.50	108	19	8.00	6.30	9	3	8.5	-	E600M10NO1	
10	1.50	108	19	8.00	6.30	9	3	8.5	-	E600M10NO2	
10	1.50	108	19	8.00	6.30	9	3	8.5	-	E600M10NO3	E610M10NO3
12	1.75	119	23	9.00	7.10	10	3	10.3	-	E600M12NO1	
12	1.75	119	23	9.00	7.10	10	3	10.3	-	E600M12NO2	
12	1.75	119	23	9.00	7.10	10	3	10.3	-	E600M12NO3	E610M12NO3
16	2.00	137	25	12.50	10.0	13	4	14	-	E600M16NO3	E610M16NO3
20	2.50	149	30	14.00	11.2	14	4	17.5	-	E600M20NO3	

N01 - N09



EP006H
EP006G
EP00TiN
EP016H

- M Maschi a macchina imbocco corretto Fornito in HSS-E fino a nuovo stock
- M Maschinen-Gewindebohrer, geradegenutet mit Schälanschnitt Lieferung in HSS-E bis neuer Lagerbestand verfügbar ist
- M Machinetap met schilaansnijding Geleverd in HSS-E tot de nieuwe voorraad beschikbaar is
- M Tarauds machine Coupe gun Fourni en HSS-E jusqu'à ce que le nouveau stock soit disponible

EP006H; EP006G	▪	1.1	1.2	1.3	1.4	1.5	6.1	6.3	7.1	7.2	7.3	7.4
	•	1.6	3.1	3.2	3.3	3.4	4.1	4.2	5.1	5.2	6.2	8.1
EP00TiN	▪	1.1	1.2	1.3	1.4	1.5	2.1	2.2	6.1	6.3	7.3	7.4
	•	1.6	2.3	3.1	3.2	3.3	3.4	4.1	4.2	5.1	5.2	6.2
EP016H	▪	1.1	1.2	1.3	1.4	1.5						
	•	1.6	2.1	2.2	2.3	3.1	3.2	3.3	3.4			

EP006H	M	DIN 371≤10 376≥12	6H		2.5XD	HSS-E PM	B 3.5-5				L001 337	L114 334
EP006G	M	DIN 371≤10 376≥12	6G		2.5XD	HSS-E PM	B 3.5-5					
EP00TiN	M	DIN 371≤10 376≥12	6H		2.5XD	HSS-E PM	B 3.5-5			TiN		
EP016H	M	DIN 371≤10 376≥12	6H		2.5XD	HSS-E PM	B 3.5-5			ST		

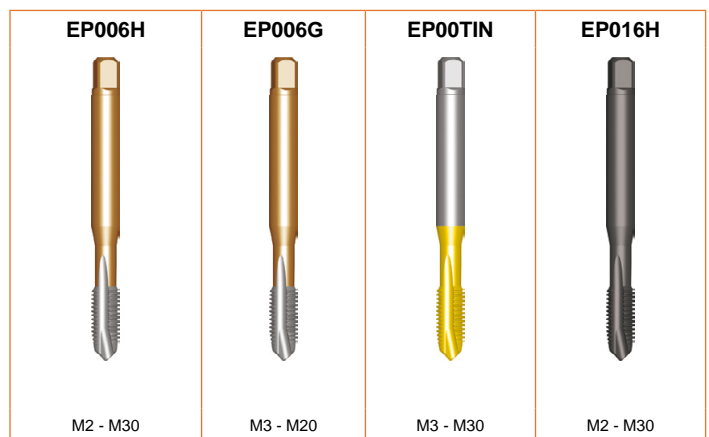
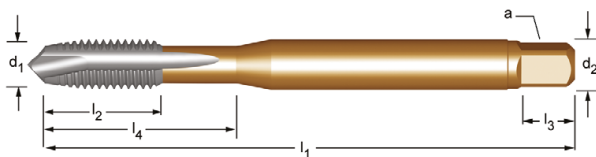

M	P mm	l ₁ mm	l ₂ mm	d ₂ ∅ mm	∠ a mm	l ₃ mm	z		l ₄ mm	EP006H	EP006G	EP00TiN	EP016H
2	0.40	50	6	2.8	2.1	5	2	1.6	9	EP00M2			EP01M2
2.5	0.45	50	8	2.8	2.1	5	2	2.1	12.5	EP00M2.5			EP01M2.5
3	0.50	56	10	2.2	1.8	4	3	2.5	18	EP00M3DIN376			EP01M3DIN376
3	0.50	56	9	3.5	2.7	6	3	2.5	18	EP00M3	EP006GM3	EP00TiNM3	EP01M3
3.5	0.60	56	11	4.0	3.0	6	3	2.9	20	EP00M3.5			EP01M3.5
4	0.70	63	12	2.8	2.1	5	3	3.3	21	EP00M4DIN376			EP01M4DIN376
4	0.70	63	12	4.5	3.4	6	3	3.3	21	EP00M4	EP006GM4	EP00TiNM4	EP01M4
4.5	0.75	70	13	6.0	4.9	8	3	3.8	25	EP00M4.5			EP01M4.5
5	0.80	70	13	3.5	2.7	6	3	4.2	25	EP00M5DIN376			EP01M5DIN376
5	0.80	70	13	6.0	4.9	8	3	4.2	25	EP00M5	EP006GM5	EP00TiNM5	EP01M5
6	1.00	80	15	4.5	3.4	6	3	5	30	EP00M6DIN376			EP01M6DIN376
6	1.00	80	15	6.0	4.9	8	3	5	30	EP00M6	EP006GM6	EP00TiNM6	EP01M6
7	1.00	80	15	7.0	5.5	8	3	6	30	EP00M7			EP01M7
8	1.25	90	18	6.0	4.9	8	3	6.8	35	EP00M8DIN376			EP01M8DIN376
8	1.25	90	18	8.0	6.2	9	3	6.8	35	EP00M8	EP006GM8	EP00TiNM8	EP01M8
10	1.50	100	20	10.0	8.0	11	3	8.5	39	EP00M10	EP006GM10	EP00TiNM10	EP01M10

M	P mm	l ₁ mm	l ₂ mm	d ₂ ∅ mm	□ a mm	l ₃ mm	z	 mm	l ₄ mm	EP006H	EP006G	EP00TIN	EP016H
10	1.50	100	20	7.0	5.5	8	3	8.5	-	EP00M10DIN376			EP01M10DIN376
12	1.75	110	23	9.0	7.0	10	3	10.3	-	EP00M12	EP006GM12	EP00TINM12	EP01M12
14	2.00	110	25	11.0	9.0	12	3	12	-	EP00M14		EP00TINM14	EP01M14
16	2.00	110	25	12.0	9.0	12	3	14	-	EP00M16	EP006GM16	EP00TINM16	EP01M16
18	2.50	125	30	14.0	11.0	14	4	15.5	-	EP00M18		EP00TINM18	EP01M18
20	2.50	140	30	16.0	12.0	15	4	17.5	-	EP00M20	EP006GM20	EP00TINM20	EP01M20
22	2.50	140	34	18.0	14.5	17	4	19.5	-	EP00M22		EP00TINM22	EP01M22
24	3.00	160	38	18.0	14.5	17	4	21	-	EP00M24		EP00TINM24	EP01M24
27	3.00	160	38	20.0	16.0	19	4	24	-	EP00M27		EP00TINM27	EP01M27
30	3.50	180	45	22.0	18.0	21	4	26.5	-	EP00M30		EP00TINM30	EP01M30

- E297**
- M Maschio a macchina imbocco corretto, Yellow Shark
 - M Maschinen-Gewindebohrer, geradegenutet mit Schälanschnitt, Gelbring Shark
 - M Machinetap, rechte spaangroef, Geelring Shark
 - M Tarauts machine Coupe gun, Shark bague jaune

E297 ■ 1.1 1.2 1.3 6.1 6.3
 • 1.4 1.5 6.2

E297 M 6H HSS-E PM

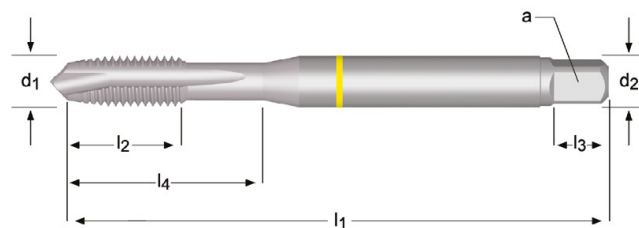

M	P mm	l ₁ mm	l ₂ mm	d ₂ ∅ mm	∠ a mm	l ₃ mm	z		l ₄ mm	E297
3	0.50	56	9	3.5	2.7	6	3	2.5	18	E297M3
4	0.70	63	12	4.5	3.4	6	3	3.3	21	E297M4
5	0.80	70	13	6.0	4.9	8	3	4.2	25	E297M5
6	1.00	80	15	6.0	4.9	8	3	5.0	30	E297M6
8	1.25	90	18	8.0	6.2	9	3	6.8	35	E297M8
10	1.50	100	20	10.0	8.0	11	3	8.5	39	E297M10
12	1.75	110	23	9.0	7.0	10	3	10.3	-	E297M12
14	2.00	110	25	11.0	9.0	12	3	12.0	-	E297M14
16	2.00	110	25	12.0	9.0	12	3	14.0	-	E297M16
18	2.50	125	30	14.0	11.0	14	3	15.5	-	E297M18
20	2.50	140	30	16.0	12.0	15	3	17.5	-	E297M20
22	2.50	140	34	18.0	14.5	17	4	19.5	-	E297M22
24	3.00	160	38	18.0	14.5	17	4	21.0	-	E297M24
27	3.00	160	38	20.0	16.0	19	4	24.0	-	E297M27
30	3.50	180	45	22.0	18.0	21	4	26.5	-	E297M30

E255

- M Maschi a macchina imbocco corretto , Red Shark
- M Maschinen-Gewindebohrer, geradegenutet mit Schälanschnitt, Rotring Shark

Fornito in HSS-E fino a nuovo stock

Lieferung in HSS-E bis neuer Lagerbestand verfügbar ist

E256

- M Machinetap, rechte spaangroef, Roodring Shark
- M Tarauds machine Coupe gun , Shark bague rouge

Geleverd in HSS-E tot de nieuwe voorraad beschikbaar is

Fourni en HSS-E jusqu'à ce que le nouveau stock soit disponible

E255	▪	1.4			
	•	1.5	1.6	4.2	5.2
E256	▪	1.4	1.5		
	•	1.6	4.2	5.2	

E255	M	DIN 371≤10 376≥12	6H		2.5XD	HSS-E PM	B 3.5-5				
E256	M	DIN 371≤10 376≥12	6H		2.5XD	HSS-E PM	B 3.5-5			TiAIN Top	

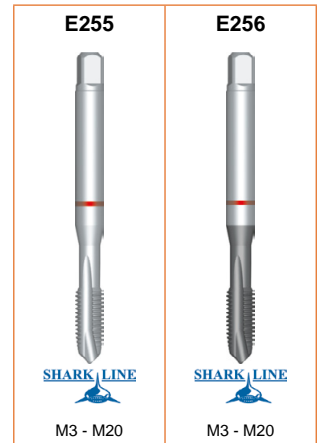
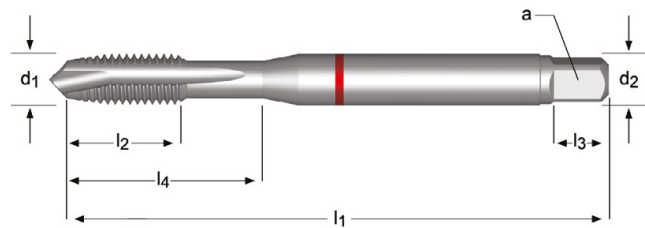

M	P mm	l ₁ mm	l ₂ mm	d ₂ ∅ mm	a mm	l ₃ mm	z		l ₄ mm	E255	E256
3	0.50	56	9	3.5	2.7	6	3	2.5	18	E255M3	E256M3
4	0.70	63	12	4.5	3.4	6	3	3.3	21	E255M4	E256M4
5	0.80	70	13	6.0	4.9	8	3	4.2	25	E255M5	E256M5
6	1.00	80	15	6.0	4.9	8	3	5.0	30	E255M6	E256M6
8	1.25	90	18	8.0	6.2	9	3	6.8	35	E255M8	E256M8
10	1.50	100	20	10.0	8.0	11	3	8.5	39	E255M10	E256M10
12	1.75	110	23	9.0	7.0	10	3	10.3	-	E255M12	E256M12
14	2.00	110	25	11.0	9.0	12	3	12.0	-	E255M14	-
16	2.00	110	25	12.0	9.0	12	3	14.0	-	E255M16	E256M16
20	2.50	140	30	16.0	12.0	15	4	17.5	-	E255M20	E256M20

- E240** • M Maschi a macchina imbocco corretto, Blue Shark
 • M Maschinen-Gewindebohrer, geradegenutet mit Schälanschnitt, Blauring Shark
- E241** • M Machinetap, rechte spaangroeven, Blauwring Shark
 • M Tarauds machine Coupe gun, Shark bague bleue

E240 ■ 2.1 2.2 2.3
 • 1.5

E241 ■ 2.1 2.2 2.3
 • 1.2 1.3 1.4 1.5

E240	M	DIN 371 ≤ 10 376 ≥ 12	6H		2.5XD	HSS-E PM	B 3.5-5			ST	
E241	M	DIN 371 ≤ 10 376 ≥ 12	6H		2.5XD	HSS-E PM	B 3.5-5			Super B	

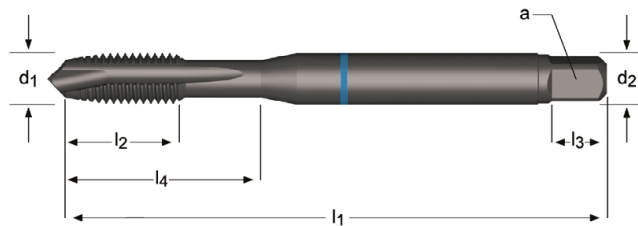

M	P mm	l ₁ mm	l ₂ mm	d ₂ ∅ mm	a mm	l ₃ mm	z		l ₄ mm	E240	E241
3	0.50	56	9	3.5	2.7	6	3	2.5	18	E240M3	E241M3
4	0.70	63	12	4.5	3.4	6	3	3.3	21	E240M4	E241M4
5	0.80	70	13	6.0	4.9	8	3	4.2	25	E240M5	E241M5
6	1.00	80	15	6.0	4.9	8	3	5.0	30	E240M6	E241M6
8	1.25	90	18	8.0	6.2	9	3	6.8	35	E240M8	E241M8
10	1.50	100	20	10.0	8.0	11	3	8.5	39	E240M10	E241M10
12	1.75	110	23	9.0	7.0	10	4	10.3	-	E240M12	E241M12
14	2.00	110	25	11.0	9.0	12	4	12.0	-	E240M14	E241M14
16	2.00	110	25	12.0	9.0	12	4	14.0	-	E240M16	E241M16
18	2.50	125	30	14.0	11.0	14	4	15.5	-	E240M18	E241M18
20	2.50	140	30	16.0	12.0	15	4	17.5	-	E240M20	E241M20
22	2.50	140	34	18.0	14.5	17	4	19.5	-	E240M22	
24	3.00	160	38	18.0	14.5	17	4	21.0	-	E240M24	
27	3.00	160	38	20.0	16.0	19	4	24.0	-	E240M27	
30	3.50	180	45	22.0	18.0	21	4	26.5	-	E240M30	

- E471**
- M Maschi a macchina imbocco corretto , Green Shark
 - M Maschinen-Gewindebohrer, geradegenutet mit Schälanschnitt, Grünring Shark
- E472**
- M Machinetap, rechte spaangroeven, Groenring Shark
 - M Tarauds machine Coupe gun , Shark bague verte

Fornito in HSS-E fino a nuovo stock

Lieferung in HSS-E bis neuer Lagerbestand verfügbar ist

Geleverd in HSS-E tot de nieuwe voorraad beschikbaar is

Fourni en HSS-E jusqu'à ce que le nouveau stock soit disponible

E471	▪	6.2	6.3	7.1	7.2	7.3	8.1
	•	1.1	1.2	1.3	6.1	7.4	
E472	▪	6.2	7.2	7.3	7.4		
	•	1.2	1.3	6.3	7.1	8.1	

E471	M	DIN 371≤10 376≥12	6H		2.5XD	HSS-E PM	B 3.5-5				
E472	M	DIN 371≤10 376≥12	6H		2.5XD	HSS-E PM	B 3.5-5			Super B	

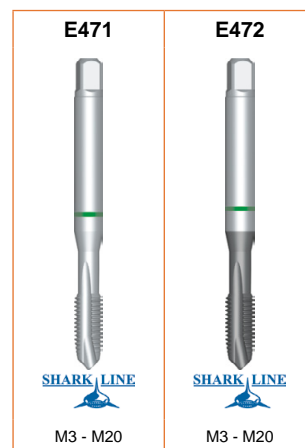
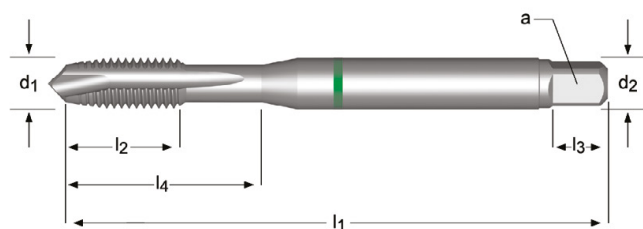

M	P mm	l ₁ mm	l ₂ mm	d ₂ ∅ mm	a mm	l ₃ mm	z		l ₄ mm	E471	E472
3	0.50	56	9	3.5	2.7	6	2	2.5	18	E471M3	E472M3
4	0.70	63	12	4.5	3.4	6	2	3.3	21	E471M4	E472M4
5	0.80	70	13	6.0	4.9	8	2	4.2	25	E471M5	E472M5
6	1.00	80	15	6.0	4.9	8	3	5.0	30	E471M6	E472M6
8	1.25	90	18	8.0	6.2	9	3	6.8	35	E471M8	E472M8
10	1.50	100	20	10.0	8.0	11	3	8.5	39	E471M10	E472M10
12	1.75	110	23	9.0	7.0	10	3	10.3	-	E471M12	E472M12
16	2.00	110	25	12.0	9.0	12	4	14.0	-	E471M16	E472M16
20	2.50	140	30	16.0	12.0	15	4	17.5	-	E471M20	E472M20

E000 E000TIN E001

- M Maschi a macchina imbocco corretto
- M Maschinen-Gewindebohrer, geradegenutet mit Schälanschnitt
- M Machinetap met schilaansnijding
- M Tarauds machine Coupe gun

Fornito in HSS-E fino a nuovo stock

Lieferung in HSS-E bis neuer Lagerbestand verfügbar ist

Geleverd in HSS-E tot de nieuwe voorraad beschikbaar is

Fourni en HSS-E jusqu'à ce que le nouveau stock soit disponible

E000	▪	1.1	1.2	1.3	1.4	1.5	6.1	6.3	7.1	7.2	7.3	7.4
	•	1.6	3.1	3.2	3.3	3.4	4.1	4.2	5.1	5.2	6.2	8.1
E000TIN	▪	1.1	1.2	1.3	1.4	1.5	2.1	2.2	6.1	6.3	7.3	7.4
	•	1.6	2.3	3.1	3.2	3.3	3.4	4.1	4.2	5.1	5.2	6.2
E001	▪	1.1	1.2	1.3	1.4	1.5						
	•	1.6	2.1	2.2	2.3	3.1	3.2	3.3	3.4			

E000	M	ISO 529	6H		2.5XD	HSS-E PM	B 3.5-5				L002 338	L113 333
E000TIN	M	ISO 529	6H		2.5XD	HSS-E PM	B 3.5-5			TIN		
E001	M	ISO 529	6H		2.5XD	HSS-E PM	B 3.5-5			ST	L113 333	

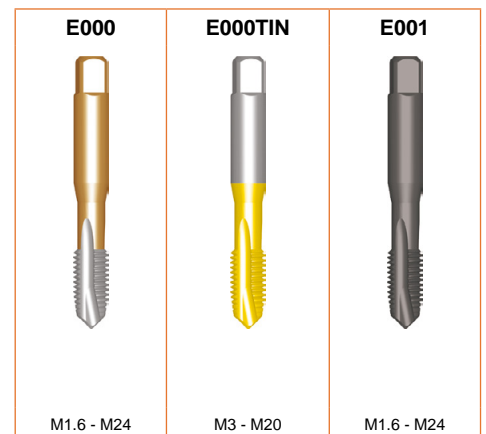
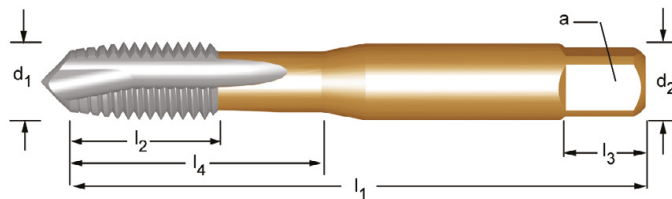

M	P mm	l ₁ mm	l ₂ mm	d ₂ Ø mm	□ a mm	l ₃ mm	z		l ₄ mm	E000	E000TIN	E001
1.6	0.35	41	7	2.50	2.00	4	2	1.25	7	E000M1.6		E001M1.6
2	0.40	41	8	2.50	2.00	4	2	1.6	8	E000M2		E001M2
2.5	0.45	44.5	9.5	2.80	2.24	5	2	2.05	9.5	E000M2.5		E001M2.5
3	0.50	48	15	3.15	2.50	5	3	2.5	15	E000M3	E000TINM3	E001M3
3.5	0.60	50	16	3.55	2.80	5	3	2.9	16	E000M3.5		E001M3.5
4	0.70	53	17	4.00	3.15	6	3	3.3	17	E000M4	E000TINM4	E001M4
5	0.80	58	11	5.00	4.00	7	3	4.2	22	E000M5	E000TINM5	E001M5
6	1.00	66	13	6.30	5.00	8	3	5.0	26	E000M6	E000TINM6	E001M6
8	1.25	72	16	8.00	6.30	9	3	6.8	29	E000M8	E000TINM8	E001M8
10	1.50	80	18	10.00	8.00	11	3	8.5	34	E000M10	E000TINM10	E001M10
12	1.75	89	22	9.00	7.10	10	3	10.3	-	E000M12	E000TINM12	E001M12
14	2.00	95	24	11.20	9.00	12	3	12.0	-	E000M14		E001M14
16	2.00	102	24	12.50	10.00	13	3	14.0	-	E000M16	E000TINM16	E001M16
18	2.50	112	29	14.00	11.20	14	4	15.5	-	E000M18		E001M18
20	2.50	112	29	14.00	11.20	14	4	17.5	-	E000M20	E000TINM20	E001M20
22	2.50	118	29	16.00	12.50	16	4	19.5	-	E000M22		E001M22
24	3.00	130	35	18.00	14.00	18	4	21.0	-	E000M24		E001M24

E606

- M Maschi a macchina, extra lungo imbocco corretto
- M Maschinen-Gewindebohrer, extra lang, geradegenutet mit Schälanschnitt
- M Machinetap, extra lang met schilaansnijding
- M Tarauds machine, Extra Long, Coupe gun

Fornito in HSS-E fino a nuovo stock

Lieferung in HSS-E bis neuer Lagerbestand verfügbar ist

Geleverd in HSS-E tot de nieuwe voorraad beschikbaar is

Fourni en HSS-E jusqu'à ce que le nouveau stock soit disponible

E606 • 1.1 1.2 1.3 1.4 1.5 1.6 2.1 2.2 2.3 4.3 5.1 5.2 6.1 6.3 7.1 7.2 7.3 7.4 8.1

E606

M

ISO
2283

6H



2.5XD

HSS-E
PM

B
3.5-5

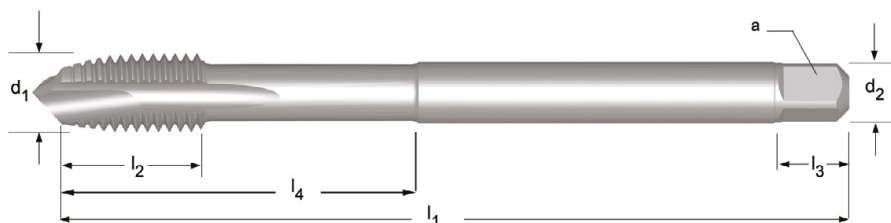

E606



M3 - M24

M	P mm	l ₁ mm	l ₂ mm	d ₂ ∅ mm	∠ a mm	l ₃ mm	z		l ₄ mm	E606
3	0.50	66	9	3.15	2.50	5	3	2.5	18	E606M3
4	0.70	73	12	3.15	2.50	5	3	3.3	-	E606M4
5	0.80	79	12	4.00	3.15	6	3	4.2	-	E606M5
6	1.00	89	14	4.50	3.55	6	3	5	-	E606M6
8	1.25	97	17	6.30	5.00	8	3	6.8	-	E606M8
10	1.50	108	19	8.00	6.30	9	3	8.5	-	E606M10
12	1.75	119	23	9.00	7.10	10	3	10.3	-	E606M12
14	2.00	127	25	11.20	9.00	12	3	12	-	E606M14
16	2.00	137	25	12.50	10.00	13	3	14	-	E606M16
20	2.50	149	30	14.00	11.20	14	4	17.5	-	E606M20
24	3.00	172	36	18.00	14.00	18	4	21	-	E606M24

- E216** • M Maschi a macchina, filettatura alternata imbocco corretto
- E266** • M Maschinen-Gewindebohrer, ausgesetzte Zähne, geradegenutet mit Schälanschnitt
- E422** • M Machinetap met schilaansnijding en onderbroken vertanding
- E423** • M Tarauds machine Coupe gun

Fornito in HSS-E fino a nuovo stock

Lieferung in HSS-E bis neuer Lagerbestand verfügbar ist

Geleverd in HSS-E tot de nieuwe voorraad beschikbaar is

Fourni en HSS-E jusqu'à ce que le nouveau stock soit disponible

E216; E266; E422; E423	▪	1.2	1.3	1.4															
	•	1.1	1.5	3.1	3.2	3.3	3.4	4.1	4.3	5.1	5.2	6.1	6.2	6.3	7.1	7.2			
		7.3	7.4	8.1															

E216	M	DIN 371	6H		3XD	HSS-E PM	B 3.5-5				
E266	M	DIN 376	6H		3XD	HSS-E PM	B 3.5-5				
E422	M	DIN 371	6H		3XD	HSS-E PM	B 3.5-5				
E423	M	DIN 376	6H		3XD	HSS-E PM	B 3.5-5				

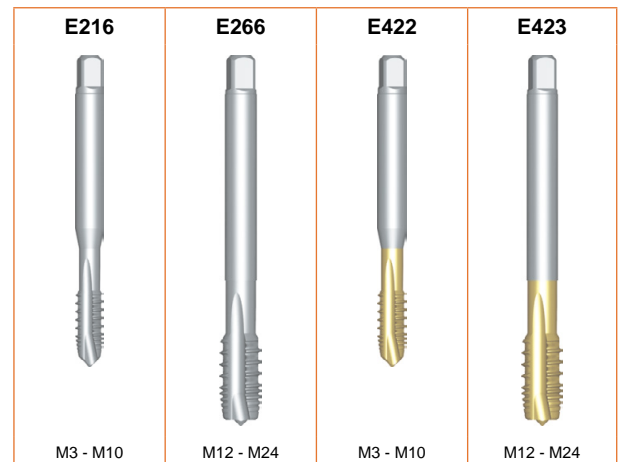
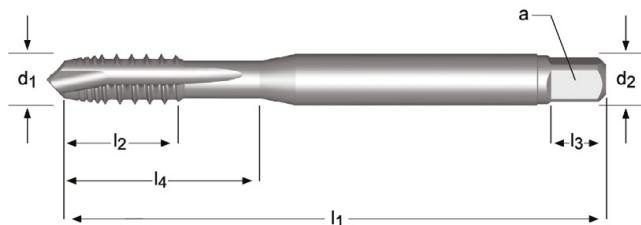

M	P mm	l ₁ mm	l ₂ mm	d ₂ Ø mm	∠ a mm	l ₃ mm	z		l ₄ mm	E216	E266	E422	E423
3	0.50	56	9	3.5	2.7	6	3	2.5	18	E216M3		E422M3	
4	0.70	63	12	4.5	3.4	6	3	3.3	21	E216M4		E422M4	
5	0.80	70	13	6.0	4.9	8	3	4.2	25	E216M5		E422M5	
6	1.00	80	15	6.0	4.9	8	3	5.0	30	E216M6		E422M6	
8	1.25	90	18	8.0	6.2	9	3	6.8	35	E216M8		E422M8	
10	1.50	100	20	10.0	8.0	11	3	8.5	39	E216M10		E422M10	
12	1.75	110	23	9.0	7.0	10	3	10.3			E266M12		E423M12
14	2.00	110	25	11.0	9.0	12	3	12.0			E266M14		E423M14
16	2.00	110	25	12.0	9.0	12	3	14.0			E266M16		E423M16
20	2.50	140	30	16.0	12.0	15	3	17.5			E266M20		E423M20
24	3.00	160	38	18.0	14.5	17	4	21.0			E266M24		E423M24

E207 • M Maschi a macchina Scanalature elicoidali 15°

Fornito in HSS-E fino a nuovo stock

E258 • M Maschinen-Gewindebohrer, rechtsgedrallte Nuten 15°

Lieferung in HSS-E bis neuer Lagerbestand verfügbar ist

E212 • M Machinetap met gespiraliseerde spaangroeven 15°

Geleverd in HSS-E tot de nieuwe voorraad beschikbaar is

E263 • M Tarauds machine goujures hélicoïdales 15°

Fourni en HSS-E jusqu'à ce que le nouveau stock soit disponible

E207; E258

- 1.3 1.4
- 1.2 1.5 7.2 7.3

E212; E263

- 1.3 1.4
- 1.1 1.2 1.5 4.2 4.3 7.2 7.3

E207	M	DIN 371	6H		1.5XD	HSS-E PM	C 2-3		$\lambda 15^\circ$			
E258	M	DIN 376	6H		1.5XD	HSS-E PM	C 2-3		$\lambda 15^\circ$			
E212	M	DIN 371	6H		1.5XD	HSS-E PM	C 2-3		$\lambda 15^\circ$			
E263	M	DIN 376	6H		1.5XD	HSS-E PM	C 2-3		$\lambda 15^\circ$			

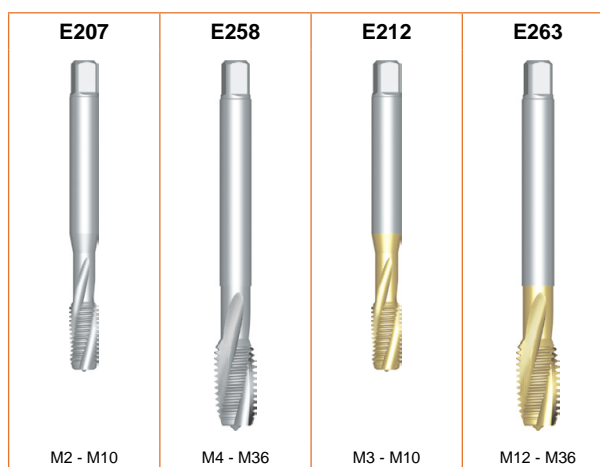
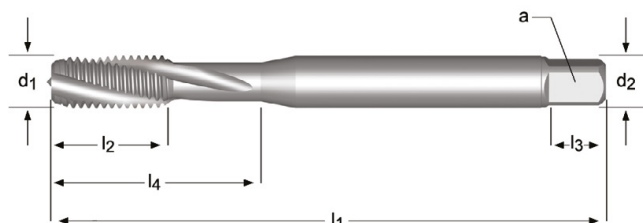

M	P mm	l ₁ mm	l ₂ mm	d ₂ Ø mm	∇ a mm	l ₃ mm	z		l ₄ mm	E207	E258	E212	E263
2	0.40	45	4	2.8	2.1	5	3	1.6	9	E207M2			
2.5	0.45	50	4	2.8	2.1	5	3	2.05	12.5	E207M2.5			
3	0.50	56	9	3.5	2.7	6	3	2.5	18	E207M3		E212M3	
4	0.70	63	12	2.8	2.1	5	3	3.3			E258M4	E212M4	
4	0.70	63	12	4.5	3.4	6	3	3.3	21	E207M4	E258M5		
5	0.80	70	13	3.5	2.7	6	3	4.2			E258M6		
5	0.80	70	13	6.0	4.9	8	3	4.2	25	E207M5		E212M5	
6	1.00	80	15	4.5	3.4	6	3	5.0			E258M8		
6	1.00	80	15	6.0	4.9	8	3	5	30	E207M6		E212M6	
8	1.25	90	18	6.0	4.9	8	3	6.8			E258M10		
8	1.25	90	18	8.0	6.2	9	3	6.8	35	E207M8		E212M8	
10	1.50	100	20	10.0	8.0	11	3	8.5	39	E207M10		E212M10	
10	1.50	100	20	7.0	5.5	8	3	8.5			E258M12		
12	1.75	110	23	9.0	7.0	10	3	10.3			E258M14		E263M12
14	2.00	110	25	11.0	9.0	12	3	12.0			E258M16		E263M14
16	2.00	110	25	12.0	9.0	12	3	14.0			E258M18		E263M16
18	2.50	125	30	14.0	11.0	14	3	15.5			E258M20		E263M18
20	2.50	140	30	16.0	12.0	15	3	17.5					E263M20

M	P mm	l ₁ mm	l ₂ mm	d ₂ ∅ mm	∇ a mm	l ₃ mm	z	 mm	l ₄ mm	E207	E258	E212	E263
22	2.50	140	34	18.0	14.5	17	4	19.5			E258M22		E263M22
24	3.00	160	38	18.0	14.5	17	4	21.0			E258M24		E263M24
27	3.00	160	38	20.0	16.0	19	4	24.0			E258M27		E263M27
30	3.50	180	45	22.0	18.0	21	4	26.5			E258M30		E263M30
36	4.00	200	55	28.0	22.0	25	4	32.0			E258M36		E263M36

EX006H EX006G EX00TIN EX016H

- M Maschi a macchina Scanalature elicoidali 45°
- M Maschinen-Gewindebohrer, rechtsgedrahte Nuten 45°
- M Machinetap met gespiraliseerde spaangroeven 45°
- M Tarauds machine goujures hélicoidales 45°

Fornito in HSS-E fino a nuovo stock

Lieferung in HSS-E bis neuer Lagerbestand verfügbar ist

Geleverd in HSS-E tot de nieuwe voorraad beschikbaar is

Fourni en HSS-E jusqu'à ce que le nouveau stock soit disponible

EX006H; EX006G	▪	1.1	1.2	1.3	1.4	1.5	7.1	7.2	7.3	7.4
	•	4.1	4.2	5.1	5.2					
EX00TIN	▪	1.1	1.2	1.3	1.4	1.5	2.1	2.2	7.3	7.4
	•	2.3	3.1	3.2	3.3	3.4	4.1	4.2	5.1	5.2
EX016H	▪	1.1	1.2	1.3	1.4	1.5	2.1	2.2		
	•	2.3								

EX006H	M	DIN 371≤10 376>12	6H		2.5XD	HSS-E PM	C 2-3				
EX006G	M	DIN 371≤10 376>12	6G		2.5XD	HSS-E PM	C 2-3				
EX00TIN	M	DIN 371≤10 376>12	6H		2.5XD	HSS-E PM	C 2-3			TIN	
EX016H	M	DIN 371≤10 376>12	6H		2.5XD	HSS-E PM	C 2-3			ST	

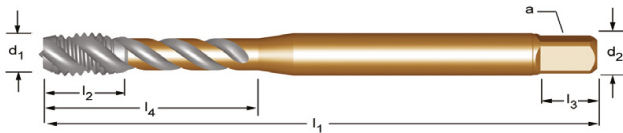

M	P mm	l ₁ mm	l ₂ mm	d ₂ ∅ mm	∠ a mm	l ₃ mm	z		l ₄ mm	EX006H	EX006G	EX00TIN	EX016H
2	0.40	45	4	2.8	2.1	5	3	1.6	9	EX00M2			EX01M2
2.5	0.45	50	4	2.8	2.1	5	3	2.05	12.5	EX00M2.5			EX01M2.5
3	0.50	56	6	3.5	2.7	6	3	2.5	18	EX00M3	EX00M36G	EX00TINM3	EX01M3
3.5	0.60	56	7	4.0	3.0	6	3	2.9	20	EX00M3.5			EX01M3.5
4	0.70	63	7	4.5	3.4	6	3	3.3	21	EX00M4	EX00M46G	EX00TINM4	EX01M4
5	0.80	70	8	6.0	4.9	8	3	4.2	25	EX00M5	EX00M56G	EX00TINM5	EX01M5
6	1.00	80	10	4.5	3.4	6	3	5	31	EX00M6DIN376			EX01M6DIN376
6	1.00	80	10	6.0	4.9	8	3	5	31	EX00M6	EX00M66G	EX00TINM6	EX01M6
7	1.00	80	10	7.0	5.5	8	3	6	31	EX00M7			EX01M7
8	1.25	90	12	8.0	6.2	9	3	6.8	35	EX00M8	EX00M86G	EX00TINM8	EX01M8
8	1.25	90	13	6.0	4.9	8	3	6.8	35	EX00M8DIN376			EX01M8DIN376
10	1.50	100	15	10.0	8.0	11	3	8.5	39	EX00M10	EX00M106G	EX00TINM10	EX01M10
10	1.50	100	15	7.0	5.5	8	3	8.5	39	EX00M10DIN376			EX01M10DIN376
12	1.75	110	16	9.0	7.0	10	3	10.3	-	EX00M12	EX00M126G	EX00TINM12	EX01M12
14	2.00	110	20	11.0	9.0	12	3	12	-	EX00M14	EX00M146G	EX00TINM14	EX01M14
16	2.00	110	20	12.0	9.0	12	4	14	-	EX00M16	EX00M166G	EX00TINM16	EX01M16
18	2.50	125	25	14.0	11.0	14	4	15.5	-	EX00M18		EX00TINM18	EX01M18
20	2.50	140	25	16.0	12.0	15	4	17.5	-	EX00M20	EX00M206G	EX00TINM20	EX01M20

M	P mm	l ₁ mm	l ₂ mm	d ₂ ∅ mm	□ a mm	l ₃ mm	z		l ₄ mm	EX006H	EX006G	EX00TIN	EX016H
22	2.50	140	25	18.0	14.5	17	4	19.5	-	EX00M22		EX00TINM22	EX01M22
24	3.00	160	30	18.0	14.5	17	4	21	-	EX00M24		EX00TINM24	EX01M24
27	3.00	160	30	20.0	16.0	19	4	24	-	EX00M27		EX00TINM27	EX01M27
30	3.50	180	36	22.0	18.0	21	4	26.5	-	EX00M30		EX00TINM30	EX01M30
33	3.50	180	36	25.0	20.0	23	4	29.5	-	EX00M33			EX01M33
36	4.00	200	40	28.0	22.0	25	4	32	-	EX00M36			EX01M36
39	4.00	200	40	32.0	24.0	27	4	35	-	EX00M39			EX01M39
42	4.50	200	45	32.0	24.0	27	4	37.5	-	EX00M42	¹⁾		EX01M42 ¹⁾
48	5.00	250	50	36.0	29.0	32	4	43	-	EX00M48	¹⁾		EX01M48 ¹⁾
52	5.00	250	50	40.0	32.0	35	5	47	-	EX00M52	¹⁾		EX01M52 ¹⁾
56	5.50	250	55	40.0	32.0	35	5	50.5	-	EX00M56	¹⁾		EX01M56 ¹⁾
64	6.00	315	60	50.0	39.0	42	6	58	-	EX00M64	¹⁾		EX01M64 ¹⁾

E298

- M Maschi a macchina Scanalature elicoidali 40° , Yellow Shark
- M Maschinen-Gewindebohrer, rechtsgedrallte Nuten 40° , Gelbring Shark
- M Machinetap, spiraalgroeven 40° , Geelring Shark
- M Tarauds machine goujures hélicoidales 40° , Shark bague jaune

E298 ■ 1.1 1.2 1.3 6.1 6.3
 • 1.4 1.5 6.2

E298 M DIN 371≤10 376≥12 6H 2XD HSS-E PM C 2-3 λ40° Cr L114 334

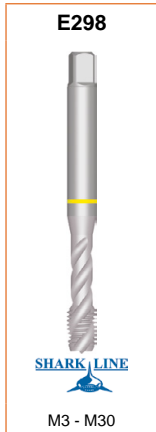
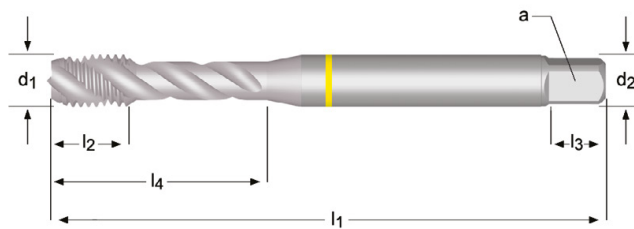

M	P mm	l ₁ mm	l ₂ mm	d ₂ Ø mm	□ a mm	l ₃ mm	z	↔	l ₄ mm	E298
3	0.50	56	6	3.5	2.7	6	3	2.5	18	E298M3
4	0.70	63	7	4.5	3.4	6	3	3.3	21	E298M4
5	0.80	70	8	6.0	4.9	8	3	4.2	25	E298M5
6	1.00	80	10	6.0	4.9	8	3	5.0	30	E298M6
8	1.25	90	13	8.0	6.2	9	3	6.8	35	E298M8
10	1.50	100	15	10.0	8.0	11	3	8.5	39	E298M10
12	1.75	110	18	9.0	7.0	10	3	10.3	-	E298M12
14	2.00	110	20	11.0	9.0	12	3	12.0	-	E298M14
16	2.00	110	20	12.0	9.0	12	4	14.0	-	E298M16
18	2.50	125	25	14.0	11.0	14	4	15.5	-	E298M18
20	2.50	140	25	16.0	12.0	15	4	17.5	-	E298M20
22	2.50	140	25	18.0	14.5	17	4	19.5	-	E298M22
24	3.00	160	30	18.0	14.5	17	4	21.0	-	E298M24
27	3.00	160	30	20.0	16.0	19	4	24.0	-	E298M27
30	3.50	160	36	22.0	18.0	21	4	26.5	-	E298M30

- E412**
- M Maschi a macchina Scanalature elicoidali 48°, Yellow Shark, rastremazione posteriore del filetto
 - M Maschinen-Gewindebohrer, rechtsgedrallte Nuten 48°, Gelbring Shark, verjüngt
 - M Machinetap, spiraalgroeven 48°, Geelring Shark, achter geslepen
 - M Tarauds machine goujures hélicoïdales 48°, Shark bague jaune, conicité arrière

E412	▪	1.1	1.2	1.3	1.4	1.5		
	•	2.1	2.2	2.3	7.1	7.2	7.3	7.4

E412

M

DIN
371≤10
376≥12

6H



3XD

HSS-E
PM

C
2-3



TAIN Top

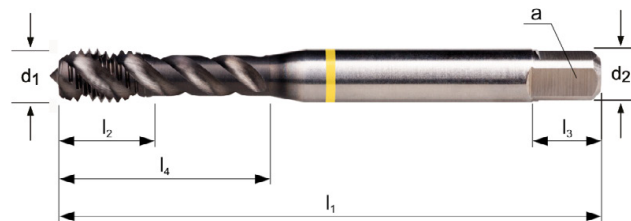

E412



SHARK LINE

M3 - M30

M	P mm	l ₁ mm	l ₂ mm	d ₂ ∅ mm	∟ a mm	l ₃ mm	z		l ₄ mm	E412
3	0.50	56	6	3.5	2.7	6	3	2.5	18	E412M3
4	0.70	63	7	4.5	3.4	6	3	3.3	21	E412M4
5	0.80	70	8	6.0	4.9	8	3	4.2	25	E412M5
6	1.00	80	10	6.0	4.9	8	3	5.0	30	E412M6
8	1.25	90	13	8.0	6.2	9	3	6.8	35	E412M8
10	1.50	100	15	10.0	8.0	11	3	8.5	39	E412M10
12	1.75	110	18	9.0	7.0	10	3	10.3	-	E412M12
14	2.00	110	20	11.0	9.0	12	3	12.0	-	E412M14
16	2.00	110	20	12.0	9.0	12	4	14.0	-	E412M16
20	2.50	140	25	16.0	12.0	15	4	17.5	-	E412M20
22	2.50	140	25	18.0	14.5	17	4	19.5	-	E412M22
24	3.00	160	30	18.0	14.5	17	4	21.0	-	E412M24
27	3.00	160	30	20.0	16.0	19	4	24.0	-	E412M27
30	3.50	180	36	22.0	18.0	21	4	26.5	-	E412M30

E260

E261

- M Maschi a macchina Scanalature elicoidali 45°, Red Shark, rastremazione posteriore del filetto
- M Maschinen-Gewindebohrer, rechtsgedrallte Nuten 45°, Rotring Shark, abgeflacht
- M Machinetap, spiraalgroeven 45°, Roodring Shark, achter geslepen
- M Tarauds machine goujures hélicoidales 45°, Shark bague rouge, conicité arrière

Fornito in HSS-E fino a nuovo stock

Lieferung in HSS-E bis neuer Lagerbestand verfügbar ist

Geleverd in HSS-E tot de nieuwe voorraad beschikbaar is

Fourni en HSS-E jusqu'à ce que le nouveau stock soit disponible

E260	▪	1.4			
	•	1.5	1.6	4.2	5.2
E261	▪	1.4	1.5		
	•	1.6	4.2	5.2	

E260	M	DIN 371≤10 376≥12	6H		2.5XD	HSS-E PM	C 2-3				
E261	M	DIN 371≤10 376≥12	6H		2.5XD	HSS-E PM	C 2-3			TAIN Top	

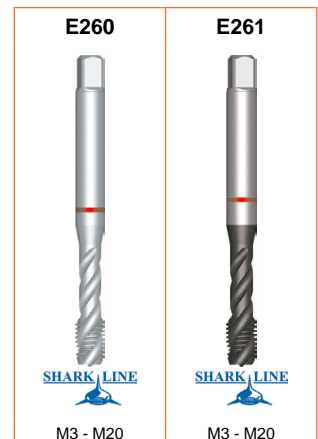
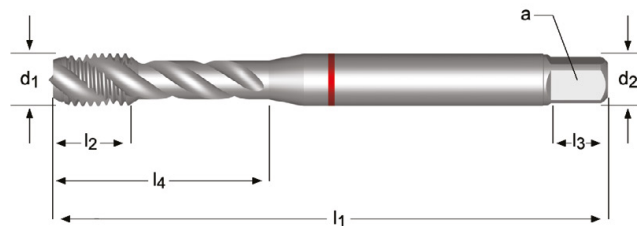

M	P mm	l ₁ mm	l ₂ mm	d ₂ ∅ mm	a mm	l ₃ mm	z		l ₄ mm	E260	E261
3	0.50	56	6	3.5	2.7	6	3	2.5	18	E260M3	E261M3
4	0.70	63	7	4.5	3.4	6	3	3.3	21	E260M4	E261M4
5	0.80	70	8	6.0	4.9	8	3	4.2	25	E260M5	E261M5
6	1.00	80	10	6.0	4.9	8	3	5.0	30	E260M6	E261M6
8	1.25	90	12	8.0	6.2	9	3	6.8	35	E260M8	E261M8
10	1.50	100	15	10.0	8.0	11	3	8.5	39	E260M10	E261M10
12	1.75	110	16	9.0	7.0	10	3	10.3	-	E260M12	E261M12
14	2.00	110	20	11.0	9.0	12	3	12.0	-	E260M14	-
16	2.00	110	20	12.0	9.0	12	4	14.0	-	E260M16	E261M16
20	2.50	140	25	16.0	12.0	15	4	17.5	-	E260M20	E261M20

E238

E239

- M Maschi a macchina Scanalature elicoidali 40°, Blue Shark, rastremazione posteriore del filetto
- M Maschinen-Gewindebohrer, rechtsgedrallte Nuten 40°, Blauring Shark, abgeflacht
- M Machinetap, spiraalgroeven 40°, Blauwring Shark, achter geslepen
- M Tarauds machine goujures hélicoidales 40°, Shark bague bleue, conicité arrière

Fornito in HSS-E fino a nuovo stock

Lieferung in HSS-E bis neuer Lagerbestand verfügbar ist

Geleverd in HSS-E tot de nieuwe voorraad beschikbaar is

Fourni en HSS-E jusqu'à ce que le nouveau stock soit disponible

E238	▪	2.1	2.2	2.3	
	•	1.5			
E239	▪	2.1	2.2	2.3	
	•	1.2	1.3	1.4	1.5

E238	M	DIN 371 ≤ 10 376 ≥ 12	6H		2.5XD	HSS-E PM	C 2-3		λ 40°		ST	
E239	M	DIN 371 ≤ 10 376 ≥ 12	6H		2.5XD	HSS-E PM	C 2-3		λ 40°		Super B	

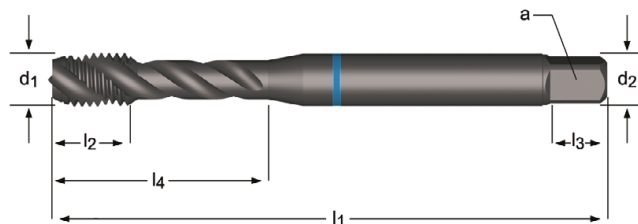

M	P mm	l ₁ mm	l ₂ mm	d ₂ Ø mm	□ a mm	l ₃ mm	z		l ₄ mm	E238	E239
3	0.50	56	6	3.5	2.7	6	3	2.5	18	E238M3	E239M3
4	0.70	63	7	4.5	3.4	6	3	3.3	21	E238M4	E239M4
5	0.80	70	8	6.0	4.9	8	3	4.2	25	E238M5	E239M5
6	1.00	80	10	6.0	4.9	8	3	5.0	30	E238M6	E239M6
8	1.25	90	13	8.0	6.2	9	3	6.8	33	E238M8	E239M8
10	1.50	100	15	10.0	8.0	11	3	8.5	39	E238M10	E239M10
12	1.75	110	18	9.0	7.0	10	4	10.3	-	E238M12	E239M12
14	2.00	110	20	11.0	9.0	12	4	12.0	-	E238M14	E239M14
16	2.00	110	20	12.0	9.0	12	4	14.0	-	E238M16	E239M16
18	2.50	125	25	14.0	11.0	14	4	15.5	-	E238M18	
20	2.50	140	25	16.0	12.0	15	4	17.5	-	E238M20	E239M20
22	2.50	140	25	18.0	14.5	17	4	19.8	-	E238M22	
24	3.00	160	30	18.0	14.5	17	4	21.0	-	E238M24	
27	3.00	160	30	20.0	16.0	19	4	24.0	-	E238M27	
30	3.50	180	36	22.0	18.0	21	4	26.5	-	E238M30	

E414

- M Maschi a macchina Scanalature elicoidali 48°, Blue Shark, rastremazione posteriore del filetto
- M Maschinen-Gewindebohrer, rechtsgedrallte Nuten 48°, Blauring Shark, verjüngt
- M Machinetap, spiraalgroeven 48°, Blauring Shark, achter geslepen
- M Tarauds machine goujures hélicoidales 48°, Shark bague bleue, conicité arrière

E414 ■ 2.1 2.2 2.3 2.4
 • 1.3 1.4 1.5

E414 M DIN 371≤10 376≥12 6H 3XD HSS-E PM C 2-3 λ48° Super B

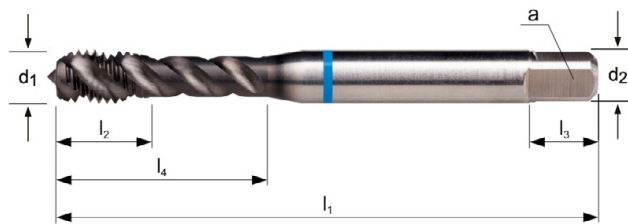

M	P mm	l ₁ mm	l ₂ mm	d ₂ ∅ mm	a mm	l ₃ mm	z	↔	l ₄ mm	E414
3	0.50	56	6	3.5	2.7	6	3	2.5	18	E414M3
4	0.70	63	7	4.5	3.4	6	3	3.3	21	E414M4
5	0.80	70	8	6.0	4.9	8	3	4.2	25	E414M5
6	1.00	80	10	6.0	4.9	8	3	5.0	30	E414M6
8	1.25	90	13	8.0	6.2	9	3	6.8	35	E414M8
10	1.50	100	15	10.0	8.0	11	3	8.5	39	E414M10
12	1.75	110	18	9.0	7.0	10	3	10.3	-	E414M12
14	2.00	110	20	11.0	9.0	12	3	12.0	-	E414M14
16	2.00	110	20	12.0	9.0	12	4	14.0	-	E414M16
20	2.50	140	25	16.0	12.0	15	4	17.5	-	E414M20

E473

- M Maschi a macchina Scanalature elicoidali 35°, Green Shark
- M Maschinen-Gewindebohrer, rechtsgedrallte Nuten 35°, Grünring Shark

Fornito in HSS-E fino a nuovo stock

E474

- M Machinetap, spiraalgroeven 35°, Groenring Shark
- M Tarauds machine goujures hélicoïdales 35°, Shark bague verte

Lieferung in HSS-E bis neuer Lagerbestand verfügbar ist

Geleverd in HSS-E tot de nieuwe voorraad beschikbaar is

Fourni en HSS-E jusqu'à ce que le nouveau stock soit disponible

E473	▪	6.2	6.3	7.1	7.2	7.3	8.1
	•	1.1	1.2	1.3	6.1	7.4	
E474	▪	6.2	7.2	7.3	7.4		
	•	1.2	1.3	6.3	7.1	8.1	

E473	M	DIN 371≤10 376≥12	6H		2.5XD	HSS-E PM	C 2-3	 λ 35°		
E474	M	DIN 371≤10 376≥12	6H		2.5XD	HSS-E PM	C 2-3	 λ 35°		Super B

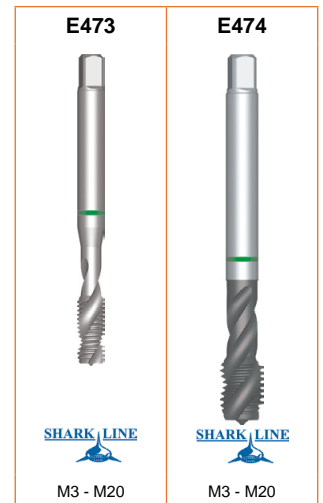
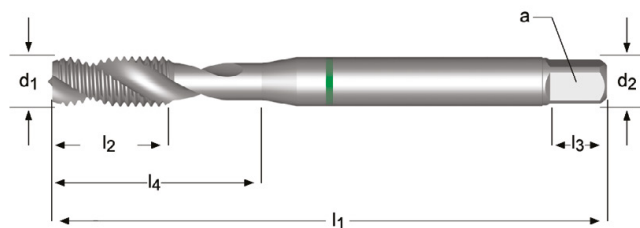

M	P mm	l ₁ mm	l ₂ mm	d ₂ ∅ mm	a mm	l ₃ mm	z		l ₄ mm	E473	E474
3	0.50	56	9	3.5	2.7	6	2	2.5	18	E473M3	E474M3
4	0.70	63	12	4.5	3.4	6	2	3.3	21	E473M4	E474M4
5	0.80	70	13	6.0	4.9	8	2	4.2	25	E473M5	E474M5
6	1.00	80	15	6.0	4.9	8	2	5.0	30	E473M6	E474M6
8	1.25	90	18	8.0	6.2	9	2	6.8	35	E473M8	E474M8
10	1.50	100	20	10.0	8.0	11	2	8.5	39	E473M10	E474M10
12	1.75	110	23	9.0	7.0	10	3	10.3	-	E473M12	E474M12
16	2.00	110	25	12.0	9.0	12	3	14.0	-	E473M16	E474M16
20	2.50	140	30	16.0	12.0	15	3	17.5	-	E473M20	E474M20

E002 E002TIN E003

- M Maschi a macchina Scanalature elicoidali 45°
- M Maschinen-Gewindebohrer, rechtsgedrallte Nuten 45°
- M Machinetap met gespiraliseerde spaangroeven 45°
- M Tarauds machine goujures hélicoidales 45°

Fornito in HSS-E fino a nuovo stock

Lieferung in HSS-E bis neuer Lagerbestand verfügbar ist

Geleverd in HSS-E tot de nieuwe voorraad beschikbaar is

Fourni en HSS-E jusqu'à ce que le nouveau stock soit disponible

E002	▪	1.1	1.2	1.3	1.4	1.5	7.1	7.2	7.3	7.4
	•	4.1	4.2	5.1	5.2					
E002TIN	▪	1.1	1.2	1.3	1.4	1.5	2.1	2.2	7.3	7.4
	•	2.3	3.1	3.2	3.3	3.4	4.1	4.2	5.1	5.2
E003	▪	1.1	1.2	1.3	1.4	1.5				
	•	2.1	2.2	2.3						

E002	M	ISO 529	6H		2.5XD	HSS-E PM	C 2-3	$\lambda 45^\circ$			L002 338	L113 333
E002TIN	M	ISO 529	6H		2.5XD	HSS-E PM	C 2-3	$\lambda 45^\circ$		TIN		
E003	M	ISO 529	6H		2.5XD	HSS-E PM	C 2-3	$\lambda 45^\circ$		ST	L113 333	

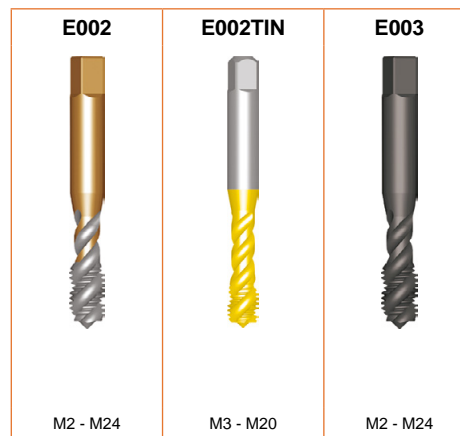
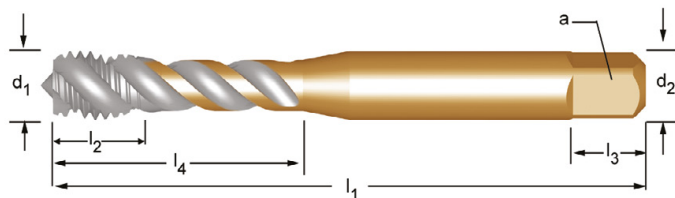

M	P mm	l ₁ mm	l ₂ mm	d ₂ ∅ mm	a mm	l ₃ mm	z		l ₄ mm	E002	E002TIN	E003
2	0.40	41	8	2.50	2.00	4	2	1.6	8	E002M2		E003M2
2.5	0.45	44.5	9.5	2.80	2.24	5	2	2.05	9.5	E002M2.5		E003M2.5
3	0.50	48	6	3.15	2.50	5	3	2.5	12.5	E002M3	E002TINM3	E003M3
4	0.70	53	7	4.00	3.15	6	3	3.3	19	E002M4	E002TINM4	E003M4
5	0.80	58	8	5.00	4.00	7	3	4.2	22	E002M5	E002TINM5	E003M5
6	1.00	66	10	6.30	5.00	8	3	5.0	27	E002M6	E002TINM6	E003M6
8	1.25	72	12	8.00	6.30	9	3	6.8	31	E002M8	E002TINM8	E003M8
10	1.50	80	15	10.00	8.00	11	3	8.5	35	E002M10	E002TINM10	E003M10
12	1.75	89	16	9.00	7.10	10	3	10.3	-	E002M12	E002TINM12	E003M12
14	2.00	95	18	11.20	9.00	12	3	12.0	-	E002M14		E003M14
16	2.00	102	18	12.50	10.00	13	4	14.0	-	E002M16	E002TINM16	E003M16
18	2.50	112	29	14.00	11.20	14	4	15.5	-	E002M18		E003M18
20	2.50	112	29	14.00	11.20	14	4	17.5	-	E002M20	E002TINM20	E003M20
22	2.50	118	29	16.00	12.50	16	4	19.5	-	E002M22		E003M22
24	3.00	130	35	18.00	14.00	18	4	21.0	-	E002M24		E003M24

- E650**
- M Punta a maschiare Scanalature elicoidali 30°
 - M Kombi-Gewindebohrer, rechtsgedrallte Nuten 30°
 - M Combi boortap met gespiraliseerde spaangroeven 30°
 - M Foret taraudeur goujures hélicoidales 30°

E650 • 1.1 1.2 1.3 1.4 3.2 6.2 6.3 7.1 7.2 8.1

E650 M DORMER ISO 6H 1.5XD HSS C 2-3 λ 30° ST L126 332

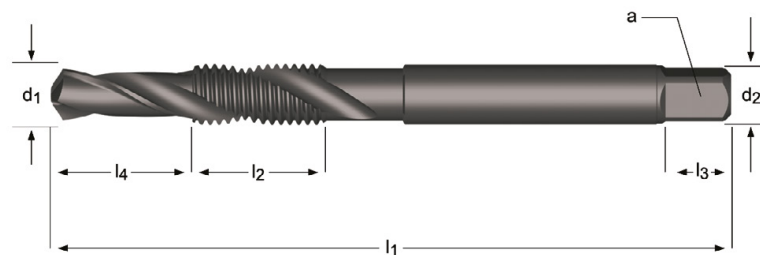

M	P mm	d ₁ nom mm	l ₁ mm	l ₂ mm	l ₄ mm	d ₂ Ø mm	∠ a mm	l ₃ mm	z	E650
3	0.50	2.5	56	10	6	3.15	2.5	5.0	2	E650M3
4	0.70	3.3	65	12	8	4.0	3.15	6.0	2	E650M4
5	0.80	4.2	69	15	10	5.0	4.00	7.0	2	E650M5
6	1.00	5.0	84	18	12	6.3	5.00	8.0	2	E650M6
8	1.25	6.8	96	21	16	8.0	6.30	9.0	2	E650M8
10	1.50	8.5	108	22	20	10.0	8.00	11.0	2	E650M10
12	1.75	10.2	113	29	24	9.0	7.10	10.0	2	E650M12
14	2.00	12.0	123	30	28	11.2	9.00	12.0	2	E650M14
16	2.00	14.0	134	32	32	12.5	10.00	13.0	2	E650M16

E605

- M Maschi a macchina, extra lungo Scanalature elicoidali 40°
- M Maschinen-Gewindebohrer, extra lang, rechtsgedrallte Nuten 40°
- M Machinetap, extra lang met gesignaliseerde spaangroeven 40°
- M Tarauds machine, Extra Long goujures hélicoidales 40°

Fornito in HSS-E fino a nuovo stock

Lieferung in HSS-E bis neuer Lagerbestand verfügbar ist

Geleverd in HSS-E tot de nieuwe voorraad beschikbaar is

Fourni en HSS-E jusqu'à ce que le nouveau stock soit disponible

E605 • 1.2 1.3 1.4 1.5 2.1 2.2 2.3 5.2 7.1 7.2 7.3 7.4

E605

M

ISO
2283

6H



2XD

HSS-E
PM

C
2-3

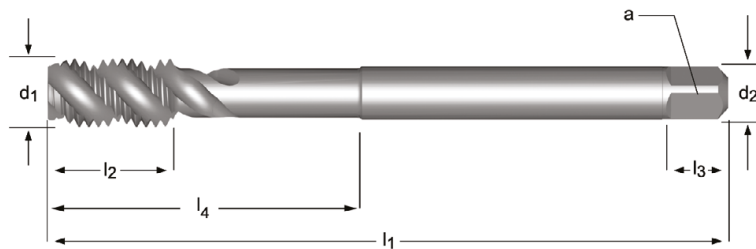

E605



M3 - M20

M	P mm	l ₁ mm	l ₂ mm	d ₂ ∅ mm	∇ a mm	l ₃ mm	z		l ₄ mm	E605
3	0.50	66	9	3.15	2.50	5	2	2.5	21	E605M3
4	0.70	73	9	4.00	3.15	6	2	3.3	22	E605M4
5	0.80	79	12	5.00	4.00	7	3	4.2	26	E605M5
6	1.00	89	12	6.30	5.00	8	3	5	29	E605M6
8	1.25	97	12	6.30	5.00	8	3	6.8	-	E605M8
10	1.50	108	14	8.00	6.30	9	3	8.5	-	E605M10
12	1.75	119	23	9.00	7.10	10	3	10.3	-	E605M12
14	2.00	127	25	11.20	9.00	12	3	12	-	E605M14
16	2.00	137	25	12.50	10.00	13	3	14	-	E605M16
20	2.50	149	30	14.00	11.20	14	3	17.5	-	E605M20

- E291** • M Maschi a rullare
• M Maschinen-Gewindeformer
- E292** • M Machineroltap
• M Tarauds machine à refouler

- E294** • M Maschi a rullare, Canalini di lubrificazione
• M Maschinen-Gewindeformer, Ölnuten / Schmiernuten
• M Machineroltap met smeergroeven
• M Tarauds machine à refouler, rainures de lubrification

- E289** • M Maschi a rullare, Canalini di lubrificazione e passaggio interno refrigerante
• M Maschinen-Gewindeformer, Ölnuten / Schmiernuten und Innenkühlung
• M Machineroltap met smeergroeven, interne koeling
• M Tarauds machine à refouler, rainures de lubrification et arrosage interne

E291	▪	1.1	1.2	1.3	1.4	7.1	7.2						
	•	7.3											
E292; E294; E289	▪	1.1	1.2	1.3	1.4	2.1	2.2	4.1	5.1	7.1	7.2	7.3	
	•	1.5	2.3	5.2	6.1	6.3	7.4						

E291	M	DIN 2174	6HX		3XD	HSS-E	C 2-3.5				
E292	M	DIN 2174	6HX		3XD	HSS-E	C 2-3.5				
E294	M	DIN 2174	6HX		3.5XD	HSS-E	C 2-3.5				
E289	M	DIN 2174	6HX		3.5XD	HSS-E	C 2-3.5				

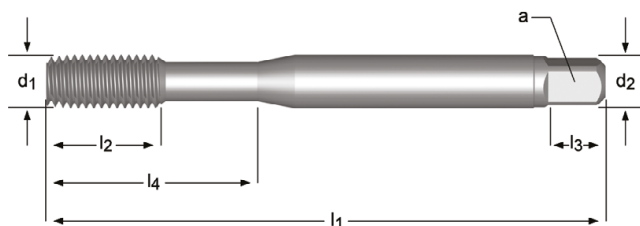

M	P mm	l ₁ mm	l ₂ mm	d ₂ Ø mm	□ a mm	l ₃ mm	z		l ₄ mm	E291	E292	E294	E289
1.6	0.35	40	8	2.5	2.1	5	3	1.4	-	E291M1.6	E292M1.6		
2	0.40	45	6	2.8	2.1	5	3	1.8	11	E291M2	E292M2		
2.5	0.45	50	8	2.8	2.1	5	3	2.3	12.5	E291M2.5	E292M2.5		
3	0.50	56	9	3.5	2.7	6	4	2.8	18	E291M3	E292M3	E294M3	
3.5	0.60	56	11	4.0	3.0	6	4	3.2	20	E291M3.5	E292M3.5		
4	0.70	63	12	4.5	3.4	6	5	3.7	21	E291M4	E292M4	E294M4	
5	0.80	70	13	6.0	4.9	8	5	4.6	25	E291M5	E292M5	E294M5	E289M5
6	1.00	80	15	6.0	4.9	8	5	5.5	30	E291M6	E292M6	E294M6	E289M6
8	1.25	90	18	8.0	6.2	9	5	7.4	35	E291M8	E292M8	E294M8	E289M8
10	1.50	100	20	10.0	8.0	11	5	9.3	39	E291M10	E292M10	E294M10	E289M10
12	1.75	110	23	9.0	7.0	10	5	11.2	-	E291M12	E292M12	E294M12	E289M12
14	2.00	110	25	11.0	9.0	12	6	13.0	-			E294M14	
16	2.00	110	25	12.0	9.0	12	6	15.0	-	E291M16	E292M16	E294M16	

E293

- M Maschi a rullare
- M Maschinen-Gewindeformer
- M Machineroltap
- M Tarauds machine à refouler

E293	▪	1.1	1.2	1.3	1.4	2.1	2.2	4.1	5.1	7.1	7.2	7.3
	•	1.5	2.3	5.2	6.1	6.3	7.4					

E293 **M** **DIN 2174** **6HX** **3XD** **HSS-E** **E 1.5-2**    

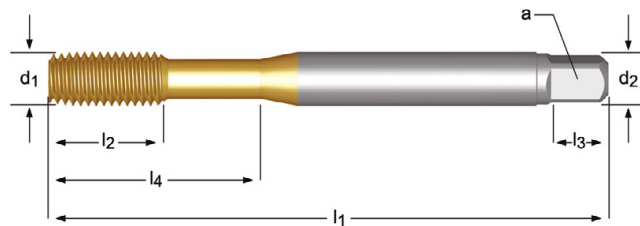

E293



M3 - M16

M	P mm	l ₁ mm	l ₂ mm	d ₂ Ø mm	□ a mm	l ₃ mm	z		l ₄ mm	E293
3	0.50	56	9	3.5	2.7	6	4	2.8	18	E293M3
4	0.70	63	12	4.5	3.4	6	5	3.7	21	E293M4
5	0.80	70	13	6.0	4.9	8	5	4.6	25	E293M5
6	1.00	80	15	6.0	4.9	8	5	5.5	30	E293M6
8	1.25	90	18	8.0	6.2	9	5	7.4	35	E293M8
10	1.50	100	20	10.0	8.0	11	5	9.3	39	E293M10
12	1.75	110	23	9.0	7.0	10	5	11.2	-	E293M12
16	2.00	110	25	12.0	9.0	12	6	15.0	-	E293M16

- E295** • M Maschi a rullare
 • M Maschinen-Gewindeformer
- E296** • M Machineroltap
 • M Tarauds machine à refouler

E295; E296 ■ 1.1 1.2 1.3 1.4 2.1 2.2 4.1 5.1 7.1 7.2 7.3
 • 1.5 2.3 5.2 6.1 6.3 7.4

E295	M	DIN 2174	6GX		3XD	HSS-E	C 2-3.5			TIN	
E296	M	DIN 2174	6GX		3XD	HSS-E	E 1.5-2			TIN	

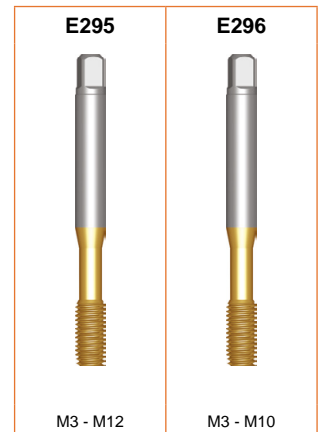
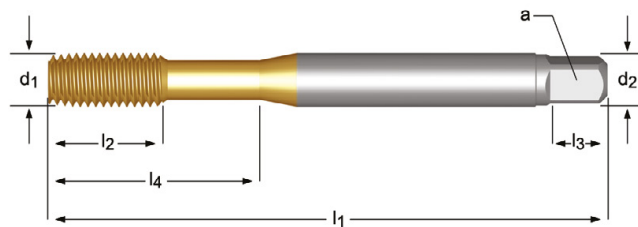

M	P mm	l ₁ mm	l ₂ mm	d ₂ Ø mm	□ a mm	l ₃ mm	z		l ₄ mm	E295	E296
3	0.50	56	9	3.5	2.7	6	4	2.8	18	E295M3	E296M3
3.5	0.60	56	11	4.0	3.0	6	4	3.2	20	E295M3.5	
4	0.70	63	12	4.5	3.4	6	5	3.7	21	E295M4	E296M4
5	0.80	70	13	6.0	4.9	8	5	4.6	25	E295M5	E296M5
6	1.00	80	15	6.0	4.9	8	5	5.5	30	E295M6	E296M6
8	1.25	90	18	8.0	6.2	9	5	7.4	35	E295M8	E296M8
10	1.50	100	20	10.0	8.0	11	5	9.3	39	E295M10	E296M10
12	1.75	110	23	9.0	7.0	10	5	11.2	-	E295M12	

E105

- MF Maschi a mano Scanalature diritte
- MF Handgewindebohrer, geradegenutet
- M Handtap met rechte spaangroeven
- MF Tarauts à main Goujures droites

E105 • 1.1 1.2 1.3 1.4 1.5 3.1 3.2 3.3 3.4 6.1 6.2 6.3 6.4 7.2 7.3 7.4 8.2 8.3

E105 MF DIN 2181 6H 1.5XD HSS C 2-3

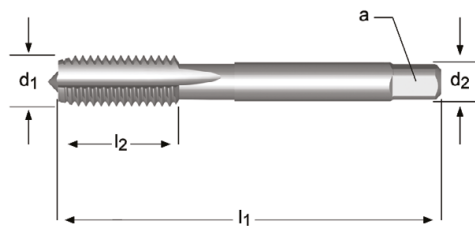

MF	P mm	l ₁ mm	l ₂ mm	d ₂ ∅ mm	a mm	z	↔	E105
2.5	0.35	40	9	2.8	2.1	3	2.15	E105M2.5X.35NO3
2.5	0.35	40	9	2.8	2.1	3	2.15	E105M2.5X.35NO9
3	0.35	40	9	3.5	2.7	3	2.65	E105M3X.35NO3
3	0.35	40	9	3.5	2.7	3	2.65	E105M3X.35NO9
3.5	0.35	45	10	4.0	3.0	3	3.2	E105M3.5X.35NO3
3.5	0.35	45	10	4.0	3.0	3	3.2	E105M3.5X.35NO9
4	0.50	45	12	4.5	3.4	3	3.5	E105M4X.5NO3
4	0.50	45	12	4.5	3.4	3	3.5	E105M4X.5NO9
5	0.50	50	14	6.0	4.9	3	4.5	E105M5X.5NO3
5	0.50	50	14	6.0	4.9	3	4.5	E105M5X.5NO9
5.5	0.50	56	16	6.0	4.9	3	5	E105M5.5X.5NO9
6	0.75	56	16	6.0	4.9	3	5.3	E105M6X.75NO3
6	0.75	56	16	6.0	4.9	3	5.3	E105M6X.75NO9
7	0.75	56	16	6.0	4.9	3	6.3	E105M7X.75NO3
7	0.75	56	16	6.0	4.9	3	6.3	E105M7X.75NO9
8	0.75	56	16	6.0	4.9	3	7.3	E105M8X.75NO3
8	0.75	56	16	6.0	4.9	3	7.3	E105M8X.75NO9
8	1.00	63	19	6.0	4.9	3	7	E105M8X1.0NO3
8	1.00	63	19	6.0	4.9	3	7	E105M8X1.0NO9
9	0.75	63	19	7.0	5.5	3	8.3	E105M9X.75NO3
9	0.75	63	19	7.0	5.5	3	8.3	E105M9X.75NO9
9	1.00	63	19	7.0	5.5	3	8	E105M9X1.0NO3
9	1.00	63	19	7.0	5.5	3	8	E105M9X1.0NO9
10	0.75	63	16	7.0	5.5	3	9.3	E105M10X.75NO3
10	0.75	63	16	7.0	5.5	3	9.3	E105M10X.75NO9
10	1.00	63	16	7.0	5.5	3	9	E105M10X1.0NO3
10	1.00	63	16	7.0	5.5	3	9	E105M10X1.0NO9
10	1.25	70	22	7.0	5.5	3	8.8	E105M10X1.25NO3
10	1.25	70	22	7.0	5.5	3	8.8	E105M10X1.25NO9
11	0.75	63	15	8.0	6.2	3	10.3	E105M11X.75NO3
11	0.75	63	15	8.0	6.2	3	10.3	E105M11X.75NO9
11	1.00	63	15	8.0	6.2	3	10	E105M11X1.0NO3
11	1.00	63	15	8.0	6.2	3	10	E105M11X1.0NO9
12	1.00	70	16	9.0	7.0	3	11	E105M12X1.0NO3
12	1.00	70	16	9.0	7.0	3	11	E105M12X1.0NO9
12	1.25	70	16	9.0	7.0	3	10.8	E105M12X1.25NO3
12	1.25	70	16	9.0	7.0	3	10.8	E105M12X1.25NO9
12	1.50	70	16	9.0	7.0	3	10.5	E105M12X1.5NO3
12	1.50	70	16	9.0	7.0	3	10.5	E105M12X1.5NO9
14	1.00	70	16	11.0	9.0	4	13	E105M14X1.0NO3

N01 - N09
219

MF	P mm	l ₁ mm	l ₂ mm	d ₂ ∅ mm	□ a mm	z		E105
14	1.00	70	16	11.0	9.0	4	13	E105M14X1.0NO9
14	1.25	70	16	11.0	9.0	4	12.8	E105M14X1.25NO3
14	1.25	70	16	11.0	9.0	4	12.8	E105M14X1.25NO9
14	1.50	70	16	11.0	9.0	4	12.5	E105M14X1.5NO3
14	1.50	70	16	11.0	9.0	4	12.5	E105M14X1.5NO9
15	1.00	70	16	12.0	9.0	4	14	E105M15X1.0NO3
15	1.00	70	16	12.0	9.0	4	14	E105M15X1.0NO9
15	1.50	70	16	12.0	9.0	4	13.5	E105M15X1.5NO3
15	1.50	70	16	12.0	9.0	4	13.5	E105M15X1.5NO9
16	1.00	70	16	12.0	9.0	4	15	E105M16X1.0NO3
16	1.00	70	16	12.0	9.0	4	15	E105M16X1.0NO9
16	1.50	70	16	12.0	9.0	4	14.5	E105M16X1.5NO3
16	1.50	70	16	12.0	9.0	4	14.5	E105M16X1.5NO9
18	1.00	80	18	14.0	11.0	4	17	E105M18X1.0NO3
18	1.00	80	18	14.0	11.0	4	17	E105M18X1.0NO9
18	1.50	80	18	14.0	11.0	4	16.5	E105M18X1.5NO3
18	1.50	80	18	14.0	11.0	4	16.5	E105M18X1.5NO9
20	1.00	80	18	16.0	12.0	4	19	E105M20X1.0NO3
20	1.00	80	18	16.0	12.0	4	19	E105M20X1.0NO9
20	1.50	80	18	16.0	12.0	4	18.5	E105M20X1.5NO3
20	1.50	80	18	16.0	12.0	4	18.5	E105M20X1.5NO9
22	1.00	80	22	18.0	14.5	4	21	E105M22X1.0NO3
22	1.00	80	22	18.0	14.5	4	21	E105M22X1.0NO9
22	1.50	80	22	18.0	14.5	4	20.5	E105M22X1.5NO3
22	1.50	80	22	18.0	14.5	4	20.5	E105M22X1.5NO9
24	1.00	90	22	18.0	14.5	4	23	E105M24X1.0NO3
24	1.00	90	22	18.0	14.5	4	23	E105M24X1.0NO9
24	1.50	90	22	18.0	14.5	4	22.5	E105M24X1.5NO3
24	1.50	90	22	18.0	14.5	4	22.5	E105M24X1.5NO9
24	2.00	90	22	18.0	14.5	4	22	E105M24X2.0NO3
24	2.00	90	22	18.0	14.5	4	22	E105M24X2.0NO9
25	1.50	90	22	18.0	14.5	4	23.5	E105M25X1.5NO3
25	1.50	90	22	18.0	14.5	4	23.5	E105M25X1.5NO9
25	2.00	90	22	18.0	14.5	4	23	E105M25X2.0NO3
25	2.00	90	22	18.0	14.5	4	23	E105M25X2.0NO9
27	1.50	90	22	20.0	16.0	4	25.5	E105M27X1.5NO3
27	1.50	90	22	20.0	16.0	4	25.5	E105M27X1.5NO9
27	2.00	90	22	20.0	16.0	4	25	E105M27X2.0NO3
27	2.00	90	22	20.0	16.0	4	25	E105M27X2.0NO9
28	1.50	90	22	20.0	16.0	4	26.5	E105M28X1.5NO3
28	1.50	90	22	20.0	16.0	4	26.5	E105M28X1.5NO9
28	2.00	90	22	20.0	16.0	4	26	E105M28X2.0NO3
28	2.00	90	22	20.0	16.0	4	26	E105M28X2.0NO9
30	1.50	90	22	22.0	18.0	4	28.5	E105M30X1.5NO3
30	1.50	90	22	22.0	18.0	4	28.5	E105M30X1.5NO9
30	2.00	90	22	22.0	18.0	4	28	E105M30X2.0NO3
30	2.00	90	22	22.0	18.0	4	28	E105M30X2.0NO9
32	1.50	90	22	22.0	18.0	4	30.5	E105M32X1.5NO3
32	1.50	90	22	22.0	18.0	4	30.5	E105M32X1.5NO9
32	2.00	90	22	22.0	18.0	4	30	E105M32X2.0NO3
32	2.00	90	22	22.0	18.0	4	30	E105M32X2.0NO9
36	1.50	100	25	28.0	22.0	4	34.5	E105M36X1.5NO3
36	1.50	100	25	28.0	22.0	4	34.5	E105M36X1.5NO9
36	2.00	125	40	28.0	22.0	4	34	E105M36X2.0NO3
36	2.00	125	40	28.0	22.0	4	34	E105M36X2.0NO9
36	3.00	125	40	28.0	22.0	4	33	E105M36X3.0NO3
36	3.00	125	40	28.0	22.0	4	33	E105M36X3.0NO9
40	1.50	110	25	32.0	24.0	4	38.5	E105M40X1.5NO3
40	1.50	110	25	32.0	24.0	4	38.5	E105M40X1.5NO9
40	2.00	125	40	32.0	24.0	4	38	E105M40X2.0NO3
40	2.00	125	40	32.0	24.0	4	38	E105M40X2.0NO9
40	3.00	125	40	32.0	24.0	4	37	E105M40X3.0NO3
40	3.00	125	40	32.0	24.0	4	37	E105M40X3.0NO9
42	1.50	110	25	32.0	24.0	4	40.5	E105M42X1.5NO3
42	1.50	110	25	32.0	24.0	4	40.5	E105M42X1.5NO9
42	2.00	125	40	32.0	24.0	4	40	E105M42X2.0NO3
42	2.00	125	40	32.0	24.0	4	40	E105M42X2.0NO9
42	3.00	125	40	32.0	24.0	4	39	E105M42X3.0NO3
42	3.00	125	40	32.0	24.0	4	39	E105M42X3.0NO9
45	1.50	110	25	36.0	29.0	6	43.5	E105M45X1.5NO3

NO1 - NO9
219

MF	P mm	l ₁ mm	l ₂ mm	d ₂ ∅ mm	□ a mm	z		E105
45	1.50	110	25	36.0	29.0	6	43.5	E105M45X1.5NO9
45	2.00	125	40	36.0	29.0	6	43	E105M45X2.0NO3
45	2.00	125	40	36.0	29.0	6	43	E105M45X2.0NO9
45	3.00	125	40	36.0	29.0	6	42	E105M45X3.0NO3
45	3.00	125	40	36.0	29.0	6	42	E105M45X3.0NO9
48	1.50	140	40	36.0	29.0	6	46.5	E105M48X1.5NO3
48	1.50	140	40	36.0	29.0	6	46.5	E105M48X1.5NO9
48	2.00	140	40	36.0	29.0	6	46	E105M48X2.0NO3
48	2.00	140	40	36.0	29.0	6	46	E105M48X2.0NO9
48	3.00	140	40	36.0	29.0	6	45	E105M48X3.0NO3
48	3.00	140	40	36.0	29.0	6	45	E105M48X3.0NO9
50	1.50	140	40	36.0	29.0	6	48.5	E105M50X1.5NO3
50	1.50	140	40	36.0	29.0	6	48.5	E105M50X1.5NO9
50	2.00	140	40	36.0	29.0	6	48	E105M50X2.0NO3
50	2.00	140	40	36.0	29.0	6	48	E105M50X2.0NO9
50	3.00	140	40	36.0	29.0	6	47	E105M50X3.0NO3
50	3.00	140	40	36.0	29.0	6	47	E105M50X3.0NO9

NO1 - NO9



219

E268 E242 E290

- MF Maschi a macchina Scanalature diritte Fornito in HSS-E fino a nuovo stock
- MF Maschinen-Gewindebohrer, geradegenutet Lieferung in HSS-E bis neuer Lagerbestand verfügbar ist
- MF Machinetap met rechte spaangroeven Geleverd in HSS-E tot de nieuwe voorraad beschikbaar is
- MF Tarauds machine Goujures droites Fourni en HSS-E jusqu'à ce que le nouveau stock soit disponible

E268; E242; E290 • 1.1 1.2 1.3 1.4 1.5 3.1 3.2 3.3 6.2 6.3 7.2 7.3 8.2

E268	MF	DIN 374	6H		1.5XD	HSS-E PM	C 2-3				
E242	MF	DIN 371	6H		1.5XD	HSS-E PM	C 2-3				
E290	MF	DIN 374	6H		1.5XD	HSS-E PM	C 2-3				

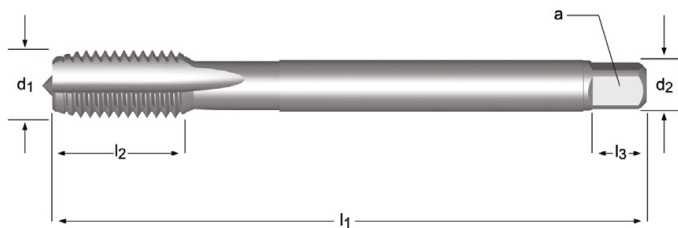

MF	P mm	l ₁ mm	l ₂ mm	d ₂ Ø mm	□ a mm	l ₃ mm	z		l ₄ mm	E268	E242	E290
4	0.50	63	10	2.8	2.1	5	3	3.5		E268M4X.5		
5	0.50	70	13	3.5	2.7	6	3	4.5		E268M5X.5		
6	0.75	80	15	4.5	3.4	6	3	5.3		E268M6X.75		
7	0.75	80	15	5.5	4.3	7	3	6.3		E268M7X.75		
8	0.75	80	15	6.0	4.9	8	3	7.3		E268M8X.75		
8	1.00	90	18	6.0	4.9	8	3	7.0		E268M8X1.0		
8	1.00	90	18	8.0	6.2	9	3	7.0	35		E242M8X1.0	
9	1.00	90	18	6.0	4.9	8	3	8.0		E268M9X1.0		
10	0.75	90	20	7.0	5.5	8	3	9.3		E268M10X.75		
10	1.00	100	20	10.0	8.0	11	3	9.0	39		E242M10X1.0	
10	1.00	90	20	7.0	5.5	8	3	9.0		E268M10X1.0		
10	1.25	100	20	7.0	5.5	8	3	8.8		E268M10X1.25		
11	1.00	90	20	8.0	6.2	9	3	10.0		E268M11X1.0		
12	1.00	100	21	9.0	7.0	10	4	11.0		E268M12X1.0		E290M12X1.0
12	1.25	100	21	9.0	7.0	10	4	10.8		E268M12X1.25		
12	1.50	100	21	9.0	7.0	10	4	10.5		E268M12X1.5		E290M12X1.5
14	1.00	100	21	11.0	9.0	12	4	13.0		E268M14X1.0		E290M14X1.0
14	1.25	100	21	11.0	9.0	12	4	12.8		E268M14X1.25		
14	1.50	100	21	11.0	9.0	12	4	12.5		E268M14X1.5		E290M14X1.5
15	1.50	100	21	12.0	9.0	12	4	13.5		E268M15X1.5		
16	1.00	100	21	12.0	9.0	12	4	15.0		E268M16X1.0		E290M16X1.0
16	1.50	100	21	12.0	9.0	12	4	14.5		E268M16X1.5		E290M16X1.5
18	1.00	110	24	14.0	11.0	14	4	17.0		E268M18X1.0		
18	1.50	110	24	14.0	11.0	14	4	16.5		E268M18X1.5		E290M18X1.5
20	1.00	125	24	16.0	12.0	15	4	19.0		E268M20X1.0		
20	1.50	125	24	16.0	12.0	15	4	18.5		E268M20X1.5		E290M20X1.5
22	1.00	125	25	18.0	14.5	17	4	21.0		E268M22X1.0		
22	1.50	125	25	18.0	14.5	17	4	20.5		E268M22X1.5		E290M22X1.5

MF	P mm	l ₁ mm	l ₂ mm	d ₂ ∅ mm	□ a mm	l ₃ mm	z		l ₄ mm	E268	E242	E290
24	1.00	140	28	18.0	14.5	17	4	23.0		E268M24X1.0		
24	1.50	140	28	18.0	14.5	17	4	22.5		E268M24X1.5		E290M24X1.5
24	2.00	140	28	18.0	14.5	17	4	22.0		E268M24X2.0		
25	1.50	140	28	18.0	14.5	17	4	23.5		E268M25X1.5		
25	2.00	140	28	18.0	14.5	17	4	23.0		E268M25X2.0		
26	1.50	140	28	18.0	14.5	17	4	24.5		E268M26X1.5		
26	2.00	140	28	18.0	14.5	17	4	24.0		E268M26X2.0		
27	1.50	140	28	20.0	16.0	19	4	25.5		E268M27X1.5		
27	2.00	140	28	20.0	16.0	19	4	25.0		E268M27X2.0		
28	1.50	140	28	20.0	16.0	19	4	26.5		E268M28X1.5		
28	2.00	140	28	20.0	16.0	19	4	26.0		E268M28X2.0		
30	1.50	150	28	22.0	18.0	21	4	28.5		E268M30X1.5		
30	2.00	150	28	22.0	18.0	21	4	28.0		E268M30X2.0		
32	1.50	150	28	22.0	18.0	21	4	30.5		E268M32X1.5		
32	2.00	150	28	22.0	18.0	21	4	30.0		E268M32X2.0		
33	1.50	160	30	25.0	20.0	23	4	31.5		E268M33X1.5		
34	1.50	170	30	28.0	22.0	25	4	32.5		E268M34X1.5		
35	1.50	170	30	28.0	22.0	25	4	33.5		E268M35X1.5		
36	1.50	170	30	28.0	22.0	25	4	34.5		E268M36X1.5		
36	2.00	170	30	28.0	22.0	25	4	34.0		E268M36X2.0		
36	3.00	200	55	28.0	22.0	25	4	33.0		E268M36X3.0		
40	1.50	170	30	32.0	24.0	27	4	38.5		E268M40X1.5		
40	2.00	170	30	32.0	24.0	27	4	38.0		E268M40X2.0		
40	3.00	200	60	32.0	24.0	27	4	37.0		E268M40X3.0		
42	1.50	170	30	32.0	24.0	27	4	40.5		E268M42X1.5	¹⁾	
42	2.00	170	30	32.0	24.0	27	4	40.0		E268M42X2.0	¹⁾	
42	3.00	200	60	32.0	24.0	27	4	39.0		E268M42X3.0	¹⁾	
45	1.50	180	32	36.0	29.0	32	6	43.5		E268M45X1.5	¹⁾	
45	2.00	180	32	36.0	29.0	32	6	43.0		E268M45X2.0	¹⁾	
45	3.00	200	42	36.0	29.0	32	6	42.0		E268M45X3.0	¹⁾	
48	1.50	190	32	36.0	29.0	32	6	46.5		E268M48X1.5	¹⁾	
48	2.00	190	32	36.0	29.0	32	6	46.0		E268M48X2.0	¹⁾	
48	3.00	225	50	36.0	29.0	32	6	45.0		E268M48X3.0	¹⁾	
50	1.50	190	32	36.0	29.0	32	6	48.5		E268M50X1.5	¹⁾	
50	2.00	190	30	36.0	29.0	32	6	48.0		E268M50X2.0	¹⁾	
50	3.00	225	50	36.0	29.0	32	6	47.0		E268M50X3.0	¹⁾	

- E513**
- MF Maschi a macchina Scanalature dritte
 - MF Maschinen-Gewindebohrer, geradegenutet
 - MF Machinetap met rechte spaangroeven
 - MF Tarauds machine Goujures droites

E513 • 1.1 1.2 1.3 1.4 1.5 3.1 3.2 3.3 3.4 6.1 6.2 6.3 6.4 7.2 7.3 7.4 8.2 8.3

E513 MF ISO 529 6H 1.5XD HSS

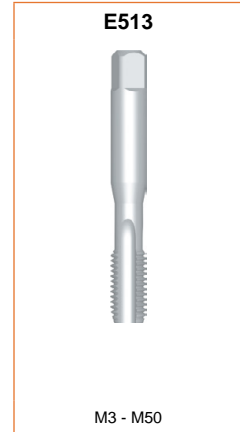
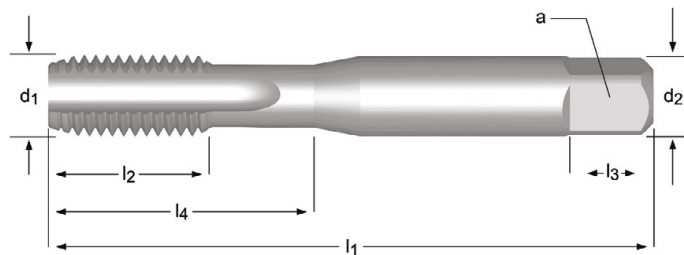

MF	P mm	l ₁ mm	l ₂ mm	d ₂ ∅ mm	a mm	l ₃ mm	z		l ₄ mm	E513
3	0.35	48	12.5	3.15	2.50	5	3	2.65	12.5	E513M3X.35NO1
3	0.35	48	12.5	3.15	2.50	5	3	2.65	12.5	E513M3X.35NO2
3	0.35	48	12.5	3.15	2.50	5	3	2.65	12.5	E513M3X.35NO3
3.5	0.35	48	12.5	3.15	2.50	5	3	3.2	12.5	E513M3.5X.35NO3
4	0.50	53	14	4.00	3.15	6	3	3.5	14	E513M4X.5NO1
4	0.50	53	14	4.00	3.15	6	3	3.5	14	E513M4X.5NO2
4	0.50	53	14	4.00	3.15	6	3	3.5	14	E513M4X.5NO3
4	0.50	53	14	4.00	3.15	6	3	3.5	14	E513M4X.5NO7
5	0.50	58	11	5.00	4.00	7	3	4.5	22	E513M5X.5NO1
5	0.50	58	11	5.00	4.00	7	3	4.5	22	E513M5X.5NO2
5	0.50	58	11	5.00	4.00	7	3	4.5	22	E513M5X.5NO3
5	0.50	58	11	5.00	4.00	7	3	4.5	22	E513M5X.5NO7
5	0.75	58	11	5.00	4.00	7	3	4.3	22	E513M5X.75NO1
5	0.75	58	11	5.00	4.00	7	3	4.3	22	E513M5X.75NO2
5	0.75	58	11	5.00	4.00	7	3	4.3	22	E513M5X.75NO3
6	0.50	66	13	6.30	5.00	8	3	5.5	26	E513M6X.5NO1
6	0.50	66	13	6.30	5.00	8	3	5.5	26	E513M6X.5NO2
6	0.50	66	13	6.30	5.00	8	3	5.5	26	E513M6X.5NO3
6	0.75	66	13	6.30	5.00	8	3	5.3	26	E513M6X.75NO1
6	0.75	66	13	6.30	5.00	8	3	5.3	26	E513M6X.75NO2
6	0.75	66	13	6.30	5.00	8	3	5.3	26	E513M6X.75NO3
6	0.75	66	13	6.30	5.00	8	3	5.3	26	E513M6X.75NO7
7	0.75	66	13	7.10	5.60	8	3	6.3	26	E513M7X.75NO1
7	0.75	66	13	7.10	5.60	8	3	6.3	26	E513M7X.75NO2
7	0.75	66	13	7.10	5.60	8	3	6.3	26	E513M7X.75NO3
8	0.50	72	16	8.00	6.30	9	3	7.5	29	E513M8X.5NO1
8	0.50	72	16	8.00	6.30	9	3	7.5	29	E513M8X.5NO2
8	0.50	72	16	8.00	6.30	9	3	7.5	29	E513M8X.5NO3
8	0.75	72	16	8.00	6.30	9	3	7.3	29	E513M8X.75NO1
8	0.75	72	16	8.00	6.30	9	3	7.3	29	E513M8X.75NO2
8	0.75	72	16	8.00	6.30	9	3	7.3	29	E513M8X.75NO3
8	0.75	72	16	8.00	6.30	9	3	7.3	29	E513M8X.75NO7
8	1.00	72	16	8.00	6.30	9	3	7	29	E513M8X1.0NO1
8	1.00	72	16	8.00	6.30	9	3	7	29	E513M8X1.0NO2
8	1.00	72	16	8.00	6.30	9	3	7	29	E513M8X1.0NO3
8	1.00	72	16	8.00	6.30	9	3	7	29	E513M8X1.0NO7
9	0.75	72	16	9.00	7.10	10	3	8.3	29	E513M9X.75NO3
9	1.00	72	16	9.00	7.10	10	3	8	29	E513M9X1.0NO1
9	1.00	72	16	9.00	7.10	10	3	8	29	E513M9X1.0NO2
9	1.00	72	16	9.00	7.10	10	3	8	29	E513M9X1.0NO3

NO1 - NO9
219

MF	P mm	l ₁ mm	l ₂ mm	d ₂ ∅ mm	□ a mm	l ₃ mm	z		l ₄ mm	E513
10	0.50	80	18	10.00	8.00	11	3	9.5	34	E513M10X.5NO3
10	0.75	80	18	10.00	8.00	11	3	9.3	34	E513M10X.75NO1
10	0.75	80	18	10.00	8.00	11	3	9.3	34	E513M10X.75NO2
10	0.75	80	18	10.00	8.00	11	3	9.3	34	E513M10X.75NO3
10	1.00	80	18	10.00	8.00	11	3	9	34	E513M10X1.0NO1
10	1.00	80	18	10.00	8.00	11	3	9	34	E513M10X1.0NO2
10	1.00	80	18	10.00	8.00	11	3	9	34	E513M10X1.0NO3
10	1.00	80	18	10.00	8.00	11	3	9	34	E513M10X1.0NO6
10	1.00	80	18	10.00	8.00	11	3	9	34	E513M10X1.0NO7
10	1.25	80	18	10.00	8.00	11	3	8.8	34	E513M10X1.25NO1
10	1.25	80	18	10.00	8.00	11	3	8.8	34	E513M10X1.25NO2
10	1.25	80	18	10.00	8.00	11	3	8.8	34	E513M10X1.25NO3
10	1.25	80	18	10.00	8.00	11	3	8.8	34	E513M10X1.25NO6
10	1.25	80	18	10.00	8.00	11	3	8.8	34	E513M10X1.25NO7
11	0.75	85	19	8.00	6.30	9	3	10.3	-	E513M11X.75NO1
11	0.75	85	19	8.00	6.30	9	3	10.3	-	E513M11X.75NO2
11	0.75	85	19	8.00	6.30	9	3	10.3	-	E513M11X.75NO3
11	1.00	85	19	8.00	6.30	9	3	10	-	E513M11X1.0NO1
11	1.00	85	19	8.00	6.30	9	3	10	-	E513M11X1.0NO2
11	1.00	85	19	8.00	6.30	9	3	10	-	E513M11X1.0NO3
11	1.25	85	19	8.00	6.30	9	3	9.8	-	E513M11X1.25NO3
12	0.75	89	22	9.00	7.10	10	3	11.3	-	E513M12X.75NO3
12	1.00	89	22	9.00	7.10	10	3	11	-	E513M12X1.0NO1
12	1.00	89	22	9.00	7.10	10	3	11	-	E513M12X1.0NO2
12	1.00	89	22	9.00	7.10	10	3	11	-	E513M12X1.0NO3
12	1.00	89	22	9.00	7.10	10	3	11	-	E513M12X1.0NO7
12	1.25	89	22	9.00	7.10	10	3	10.8	-	E513M12X1.25NO1
12	1.25	89	22	9.00	7.10	10	3	10.8	-	E513M12X1.25NO2
12	1.25	89	22	9.00	7.10	10	3	10.8	-	E513M12X1.25NO3
12	1.25	89	22	9.00	7.10	10	3	10.8	-	E513M12X1.25NO6
12	1.25	89	22	9.00	7.10	10	3	10.8	-	E513M12X1.25NO7
12	1.50	89	22	9.00	7.10	10	3	10.5	-	E513M12X1.5NO1
12	1.50	89	22	9.00	7.10	10	3	10.5	-	E513M12X1.5NO2
12	1.50	89	22	9.00	7.10	10	3	10.5	-	E513M12X1.5NO3
12	1.50	89	22	9.00	7.10	10	3	10.5	-	E513M12X1.5NO6
12	1.50	89	22	9.00	7.10	10	3	10.5	-	E513M12X1.5NO7
13	1.50	89	22	9.00	7.10	10	3	11.5	-	E513M13X1.5NO3
14	1.00	95	24	11.20	9.00	12	4	13	-	E513M14X1.0NO1
14	1.00	95	24	11.20	9.00	12	4	13	-	E513M14X1.0NO2
14	1.00	95	24	11.20	9.00	12	4	13	-	E513M14X1.0NO3
14	1.00	95	24	11.20	9.00	12	4	13	-	E513M14X1.0NO7
14	1.25	95	24	11.20	9.00	12	4	12.8	-	E513M14X1.25NO1
14	1.25	95	24	11.20	9.00	12	4	12.8	-	E513M14X1.25NO2
14	1.25	95	24	11.20	9.00	12	4	12.8	-	E513M14X1.25NO3
14	1.25	95	24	11.20	9.00	12	4	12.8	-	E513M14X1.25NO6
14	1.50	95	24	11.20	9.00	12	4	12.5	-	E513M14X1.5NO1
14	1.50	95	24	11.20	9.00	12	4	12.5	-	E513M14X1.5NO2
14	1.50	95	24	11.20	9.00	12	4	12.5	-	E513M14X1.5NO3
14	1.50	95	24	11.20	9.00	12	4	12.5	-	E513M14X1.5NO6
14	1.50	95	24	11.20	9.00	12	4	12.5	-	E513M14X1.5NO7
15	1.50	95	24	11.20	9.00	12	4	13.5	-	E513M15X1.5NO2
15	1.50	95	24	11.20	9.00	12	4	13.5	-	E513M15X1.5NO3
16	1.00	102	24	12.50	10.00	13	4	15	-	E513M16X1.0NO1
16	1.00	102	24	12.50	10.00	13	4	15	-	E513M16X1.0NO2
16	1.00	102	24	12.50	10.00	13	4	15	-	E513M16X1.0NO3
16	1.00	102	24	12.50	10.00	13	4	15	-	E513M16X1.0NO7
16	1.25	102	24	12.50	10.00	13	4	14.8	-	E513M16X1.25NO3
16	1.50	102	24	12.50	10.00	13	4	14.5	-	E513M16X1.5NO1
16	1.50	102	24	12.50	10.00	13	4	14.5	-	E513M16X1.5NO2
16	1.50	102	24	12.50	10.00	13	4	14.5	-	E513M16X1.5NO3
16	1.50	102	24	12.50	10.00	13	4	14.5	-	E513M16X1.5NO6
16	1.50	102	24	12.50	10.00	13	4	14.5	-	E513M16X1.5NO7
18	1.00	112	29	14.00	11.20	14	4	17	-	E513M18X1.0NO1
18	1.00	112	29	14.00	11.20	14	4	17	-	E513M18X1.0NO2
18	1.00	112	29	14.00	11.20	14	4	17	-	E513M18X1.0NO3
18	1.00	112	29	14.00	11.20	14	4	17	-	E513M18X1.0NO7
18	1.50	112	29	14.00	11.20	14	4	16.5	-	E513M18X1.5NO1
18	1.50	112	29	14.00	11.20	14	4	16.5	-	E513M18X1.5NO2
18	1.50	112	29	14.00	11.20	14	4	16.5	-	E513M18X1.5NO3
18	1.50	112	29	14.00	11.20	14	4	16.5	-	E513M18X1.5NO6

NO1 - NO9



219

MF	P mm	l ₁ mm	l ₂ mm	d ₂ ∅ mm	∠ a mm	l ₃ mm	z		l ₄ mm	E513
18	1.50	112	29	14.00	11.20	14	4	16.5	-	E513M18X1.5NO7
18	2.00	112	29	14.00	11.20	14	4	16	-	E513M18X2.0NO1
18	2.00	112	29	14.00	11.20	14	4	16	-	E513M18X2.0NO2
18	2.00	112	29	14.00	11.20	14	4	16	-	E513M18X2.0NO3
18	2.00	112	29	14.00	11.20	14	4	16	-	E513M18X2.0NO7
20	1.00	112	29	14.00	11.20	14	4	19	-	E513M20X1.0NO1
20	1.00	112	29	14.00	11.20	14	4	19	-	E513M20X1.0NO2
20	1.00	112	29	14.00	11.20	14	4	19	-	E513M20X1.0NO3
20	1.00	112	29	14.00	11.20	14	4	19	-	E513M20X1.0NO7
20	1.50	112	29	14.00	11.20	14	4	18.5	-	E513M20X1.5NO1
20	1.50	112	29	14.00	11.20	14	4	18.5	-	E513M20X1.5NO2
20	1.50	112	29	14.00	11.20	14	4	18.5	-	E513M20X1.5NO3
20	1.50	112	29	14.00	11.20	14	4	18.5	-	E513M20X1.5NO6
20	1.50	112	29	14.00	11.20	14	4	18.5	-	E513M20X1.5NO7
20	2.00	112	29	14.00	11.20	14	4	18	-	E513M20X2.0NO1
20	2.00	112	29	14.00	11.20	14	4	18	-	E513M20X2.0NO2
20	2.00	112	29	14.00	11.20	14	4	18	-	E513M20X2.0NO3
20	2.00	112	29	14.00	11.20	14	4	18	-	E513M20X2.0NO7
22	1.00	118	29	16.00	12.50	16	4	21	-	E513M22X1.0NO2
22	1.00	118	29	16.00	12.50	16	4	21	-	E513M22X1.0NO3
22	1.00	118	29	16.00	12.50	16	4	21	-	E513M22X1.0NO7
22	1.50	118	29	16.00	12.50	16	4	20.5	-	E513M22X1.5NO1
22	1.50	118	29	16.00	12.50	16	4	20.5	-	E513M22X1.5NO2
22	1.50	118	29	16.00	12.50	16	4	20.5	-	E513M22X1.5NO3
22	1.50	118	29	16.00	12.50	16	4	20.5	-	E513M22X1.5NO7
22	2.00	118	29	16.00	12.50	16	4	20	-	E513M22X2.0NO1
22	2.00	118	29	16.00	12.50	16	4	20	-	E513M22X2.0NO2
22	2.00	118	29	16.00	12.50	16	4	20	-	E513M22X2.0NO3
22	2.00	118	29	16.00	12.50	16	4	20	-	E513M22X2.0NO7
24	1.00	130	35	18.00	14.00	18	4	23	-	E513M24X1.0NO2
24	1.00	130	35	18.00	14.00	18	4	23	-	E513M24X1.0NO3
24	1.50	130	35	18.00	14.00	18	4	22.5	-	E513M24X1.5NO1
24	1.50	130	35	18.00	14.00	18	4	22.5	-	E513M24X1.5NO2
24	1.50	130	35	18.00	14.00	18	4	22.5	-	E513M24X1.5NO3
24	1.50	130	35	18.00	14.00	18	4	22.5	-	E513M24X1.5NO7
24	2.00	130	35	18.00	14.00	18	4	22	-	E513M24X2.0NO1
24	2.00	130	35	18.00	14.00	18	4	22	-	E513M24X2.0NO2
24	2.00	130	35	18.00	14.00	18	4	22	-	E513M24X2.0NO3
24	2.00	130	35	18.00	14.00	18	4	22	-	E513M24X2.0NO7
25	1.50	130	35	18.00	14.00	18	4	23.5	-	E513M25X1.5NO1
25	1.50	130	35	18.00	14.00	18	4	23.5	-	E513M25X1.5NO2
25	1.50	130	35	18.00	14.00	18	4	23.5	-	E513M25X1.5NO3
25	1.50	130	35	18.00	14.00	18	4	23.5	-	E513M25X1.5NO6
25	1.50	130	35	18.00	14.00	18	4	23.5	-	E513M25X1.5NO7
26	1.50	130	35	18.00	14.00	18	4	24.5	-	E513M26X1.5NO2
26	1.50	130	35	18.00	14.00	18	4	24.5	-	E513M26X1.5NO3
27	1.50	135	35	20.00	16.00	20	4	25.5	-	E513M27X1.5NO2
27	1.50	135	35	20.00	16.00	20	4	25.5	-	E513M27X1.5NO3
27	2.00	135	35	20.00	16.00	20	4	25	-	E513M27X2.0NO3
28	1.50	138	35	20.00	16.00	20	4	26.5	-	E513M28X1.5NO2
28	1.50	138	35	20.00	16.00	20	4	26.5	-	E513M28X1.5NO3
30	1.50	138	41	20.00	16.00	20	4	28.5	-	E513M30X1.5NO2
30	1.50	138	41	20.00	16.00	20	4	28.5	-	E513M30X1.5NO3
30	2.00	138	41	20.00	16.00	20	4	28	-	E513M30X2.0NO2
30	2.00	138	41	20.00	16.00	20	4	28	-	E513M30X2.0NO3
32	1.50	151	41	22.40	18.00	22	4	30.5	-	E513M32X1.5NO1
32	1.50	151	41	22.40	18.00	22	4	30.5	-	E513M32X1.5NO2
32	1.50	151	41	22.40	18.00	22	4	30.5	-	E513M32X1.5NO3
33	2.00	151	41	22.40	18.00	22	4	31	-	E513M33X2.0NO2
33	2.00	151	41	22.40	18.00	22	4	31	-	E513M33X2.0NO3
35	1.50	162	47	25.00	20.00	24	4	33.5	-	E513M35X1.5NO2
35	1.50	162	47	25.00	20.00	24	4	33.5	-	E513M35X1.5NO3
36	1.50	162	47	25.00	20.00	24	4	34.5	-	E513M36X1.5NO3
36	2.00	162	47	25.00	20.00	24	4	34	-	E513M36X2.0NO2
36	2.00	162	47	25.00	20.00	24	4	34	-	E513M36X2.0NO3
36	3.00	162	47	25.00	20.00	24	4	33	-	E513M36X3.0NO2
36	3.00	162	47	25.00	20.00	24	4	33	-	E513M36X3.0NO3
39	3.00	170	47	28.00	22.40	26	4	36	-	E513M39X3.0NO2
39	3.00	170	47	28.00	22.40	26	4	36	-	E513M39X3.0NO3
40	1.50	170	53	28.00	22.40	26	6	38.5	-	E513M40X1.5NO2

NO1 - NO9
219

MF	P mm	l ₁ mm	l ₂ mm	d ₂ ∅ mm	∇ a mm	l ₃ mm	z		l ₄ mm	E513
40	1.50	170	53	28.00	22.40	26	6	38.5	-	E513M40X1.5NO3
42	1.50	170	53	28.00	22.40	26	6	40.5	-	E513M42X1.5NO2
42	1.50	170	53	28.00	22.40	26	6	40.5	-	E513M42X1.5NO3
42	3.00	170	53	28.00	22.40	26	6	39	-	E513M42X3.0NO3
45	1.50	187	54	31.50	25.00	28	6	43.5	-	E513M45X1.5NO2
45	1.50	187	54	31.50	25.00	28	6	43.5	-	E513M45X1.5NO3
48	1.50	187	60	31.50	25.00	28	6	46.5	-	E513M48X1.5NO3
48	2.00	187	60	31.50	25.00	28	6	46	-	E513M48X2.0NO3
48	3.00	187	60	31.50	25.00	28	6	45	-	E513M48X3.0NO3
50	1.50	187	60	31.50	25.00	28	6	48.5	-	E513M50X1.5NO2
50	1.50	187	60	31.50	25.00	28	6	48.5	-	E513M50X1.5NO3

N01 - N09



219

EP10 EP10TIN EP11

- MF Maschi a macchina imbocco corretto
- MF Maschinen-Gewindebohrer, geradegenutet mit Schälanschnitt
- MF Machinetap met schilaansnijding
- MF Tarauds machine Coupe gun

Fornito in HSS-E fino a nuovo stock

Lieferung in HSS-E bis neuer Lagerbestand verfügbar ist

Geleverd in HSS-E tot de nieuwe voorraad beschikbaar is

Fourni en HSS-E jusqu'à ce que le nouveau stock soit disponible

EP10	▪	1.1	1.2	1.3	1.4	1.5	6.1	6.3	7.1	7.2	7.3	7.4
	•	1.6	3.1	3.2	3.3	3.4	4.1	4.2	5.1	5.2	6.2	8.1
EP10TIN	▪	1.1	1.2	1.3	1.4	1.5	2.1	2.2	6.1	6.3	7.3	7.4
	•	1.6	2.3	3.1	3.2	3.3	3.4	4.1	4.2	5.1	5.2	6.2
EP11	▪	1.1	1.2	1.3	1.4	1.5						
	•	1.6	2.1	2.2	2.3	3.1	3.2	3.3	3.4			

EP10	MF	DIN 374	6H		2.5XD	HSS-E PM	B 3.5-5			
EP10TIN	MF	DIN 374	6H		2.5XD	HSS-E PM	B 3.5-5			TIN
EP11	MF	DIN 374	6H		2.5XD	HSS-E PM	B 3.5-5			ST

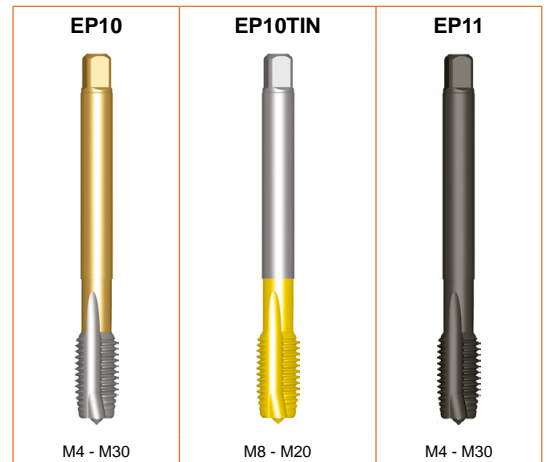
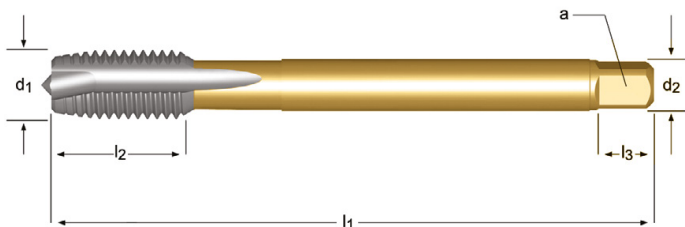

MF	P mm	l ₁ mm	l ₂ mm	d ₂ mm	∠ a mm	l ₃ mm	z		EP10	EP10TIN	EP11
4	0.50	63	12	2.8	2.1	5	3	3.5	EP10M4X.5		EP11M4X.5
5	0.50	70	13	3.5	2.7	6	3	4.5	EP10M5X.5		EP11M5X.5
6	0.75	80	15	4.5	3.4	6	3	5.3	EP10M6X.75		EP11M6X.75
8	0.75	80	15	6.0	4.9	8	3	7.3	EP10M8X.75		EP11M8X.75
8	1.00	90	18	6.0	4.9	8	3	7	EP10M8X1.0	EP10TINM8X1.0	EP11M8X1.0
10	0.75	90	18	7.0	5.5	8	3	9.3	EP10M10X.75		EP11M10X.75
10	1.00	90	18	7.0	5.5	8	3	9	EP10M10X1.0	EP10TINM10X1.0	EP11M10X1.0
10	1.25	100	20	7.0	5.5	8	3	8.8	EP10M10X1.25	EP10TINM10X1.25	EP11M10X1.25
12	1.00	100	21	9.0	7.0	10	3	11	EP10M12X1.0	EP10TINM12X1.0	EP11M12X1.0
12	1.25	100	21	9.0	7.0	10	3	10.8	EP10M12X1.25	EP10TINM12X1.25	EP11M12X1.25
12	1.50	100	21	9.0	7.0	10	3	10.5	EP10M12X1.5	EP10TINM12X1.5	EP11M12X1.5
14	1.00	100	21	11.0	9.0	12	3	13	EP10M14X1.0		EP11M14X1.0
14	1.25	100	21	11.0	9.0	12	3	13	EP10M14X1.25		EP11M14X1.25
14	1.50	100	21	11.0	9.0	12	3	12.5	EP10M14X1.5	EP10TINM14X1.5	EP11M14X1.5
16	1.00	100	21	12.0	9.0	12	3	15	EP10M16X1.0		EP11M16X1.0
16	1.50	100	21	12.0	9.0	12	3	14.5	EP10M16X1.5	EP10TINM16X1.5	EP11M16X1.5
18	1.00	110	24	14.0	11.0	14	4	17	EP10M18X1.0		EP11M18X1.0
18	1.50	110	24	14.0	11.0	14	4	16.5	EP10M18X1.5	EP10TINM18X1.5	EP11M18X1.5
20	1.00	125	24	16.0	12.0	15	4	19	EP10M20X1.0		EP11M20X1.0
20	1.50	125	24	16.0	12.0	15	4	18.5	EP10M20X1.5	EP10TINM20X1.5	EP11M20X1.5

MF	P mm	l ₁ mm	l ₂ mm	d ₂ ∅ mm	□ a mm	l ₃ mm	z		EP10	EP10TIN	EP11
22	1.50	125	25	18.0	14.5	17	4	20.5	EP10M22X1.5		EP11M22X1.5
24	1.50	140	28	18.0	14.5	17	4	22.5	EP10M24X1.5		EP11M24X1.5
24	2.00	140	28	18.0	14.5	17	4	22	EP10M24X2.0		EP11M24X2.0
25	1.50	140	28	18.0	14.5	17	4	23.5	EP10M25X1.5		EP11M25X1.5
26	1.50	140	28	18.0	14.5	17	4	24.5	EP10M26X1.5		EP11M26X1.5
27	1.50	140	28	20.0	16.0	19	4	25.5	EP10M27X1.5		EP11M27X1.5
27	2.00	140	28	20.0	16.0	19	4	25	EP10M27X2.0		EP11M27X2.0
28	1.50	140	28	20.0	16.0	19	4	26.5	EP10M28X1.5		EP11M28X1.5
30	1.50	150	28	22.0	18.0	21	4	28.5	EP10M30X1.5		EP11M30X1.5
30	2.00	150	28	22.0	18.0	21	4	28	EP10M30X2.0		EP11M30X2.0

- E299**
- MF Maschio a macchina imbocco corretto, Yellow Shark
 - MF Maschinen-Gewindebohrer, geradegenutet mit Schälanschnitt, Gelbring Shark
 - MF Machinetap, rechte spaangroef, Geelring Shark
 - MF Tarauds machine Coupe gun, Shark bague jaune

E299 ■ 1.1 1.2 1.3 6.1 6.3
 • 1.4 1.5 6.2

E299 MF DIN 374 6H 2.5XD HSS-E PM B 3.5-5 Cr

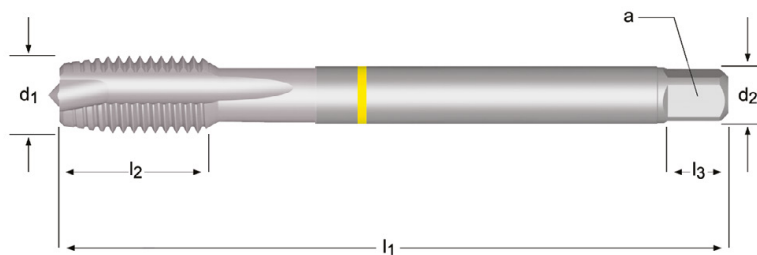

MF	P mm	l ₁ mm	l ₂ mm	d ₂ Ø mm	□ a mm	l ₃ mm	z	↔	E299
4	0.50	63	12	2.8	2.1	5	3	3.5	E299M4X.5
5	0.50	70	13	3.5	2.7	6	3	4.5	E299M5X.5
6	0.75	80	15	4.5	3.4	6	3	5.3	E299M6X.75
8	0.75	80	15	6.0	4.9	8	3	7.3	E299M8X.75
8	1.00	90	18	6.0	4.9	8	3	7.0	E299M8X1.0
10	0.75	90	20	7.0	5.5	8	3	9.3	E299M10X.75
10	1.00	90	20	7.0	5.5	8	3	9.0	E299M10X1.0
10	1.25	100	20	7.0	5.5	8	3	8.8	E299M10X1.25
12	1.00	100	21	9.0	7.0	10	4	11.0	E299M12X1.0
12	1.25	100	21	9.0	7.0	10	4	10.8	E299M12X1.25
12	1.50	110	21	9.0	7.0	10	4	10.5	E299M12X1.5
14	1.00	100	21	11.0	9.0	12	4	13.0	E299M14X1.0
14	1.25	100	21	11.0	9.0	12	4	12.8	E299M14X1.25
14	1.50	100	21	11.0	9.0	12	4	12.5	E299M14X1.5
16	1.00	100	21	12.0	9.0	12	4	15.0	E299M16X1.0
16	1.50	100	21	12.0	9.0	12	4	14.5	E299M16X1.5
18	1.00	110	24	14.0	11.0	14	4	17.0	E299M18X1.0
18	1.50	110	24	14.0	11.0	14	4	16.5	E299M18X1.5
20	1.50	125	24	16.0	12.0	15	4	18.5	E299M20X1.5
22	1.50	125	25	18.0	14.5	17	4	20.5	E299M22X1.5
24	1.50	140	28	18.0	14.5	17	4	22.5	E299M24X1.5
24	2.00	140	28	18.0	14.5	17	4	22.0	E299M24X2.0
27	2.00	140	28	20.0	16.0	19	4	25.0	E299M27X2.0
30	2.00	150	28	22.0	18.0	21	4	28.0	E299M30X2.0

E384

- MF Maschi a macchina imbocco corretto, Blue Shark
- MF Maschinen-Gewindebohrer, geradegenutet mit Schälanschnitt, Blauring Shark
- MF Machinetap, rechte spaangroef, Blauwring Shark
- MF Tarauds machine Coupe gun, Shark bague bleue

E384 ■ 2.1 2.2 2.3
 • 1.5

E384 MF DIN 374 6H 2.5XD HSS-E PM B 3.5-5    

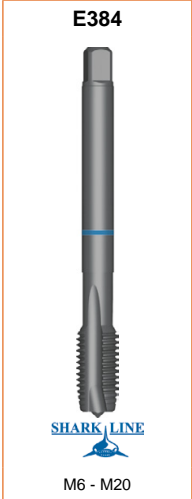
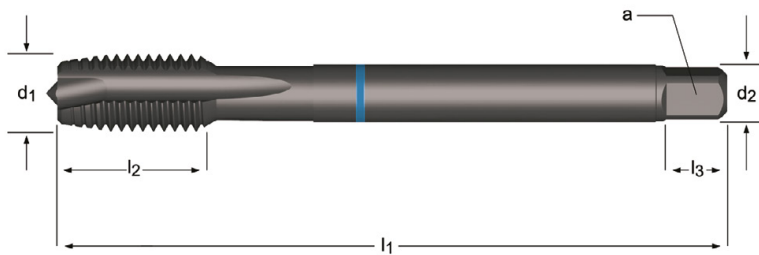

MF	P mm	l ₁ mm	l ₂ mm	d ₂ Ø mm	∠ a mm	l ₃ mm	z		E384
6	0.75	80	15	4.5	3.4	6	3	5.3	E384M6X.75
8	1.00	90	18	6.0	4.9	8	3	7.0	E384M8X1.0
10	1.00	90	20	7.0	5.5	8	3	9.0	E384M10X1.0
10	1.25	100	20	7.0	5.5	8	3	8.8	E384M10X1.25
12	1.00	100	21	9.0	7.0	10	4	11.0	E384M12X1.0
12	1.25	100	21	9.0	7.0	10	4	10.8	E384M12X1.25
12	1.50	100	21	9.0	7.0	10	4	10.5	E384M12X1.5
14	1.50	100	21	11.0	9.0	12	4	12.5	E384M14X1.5
16	1.50	100	21	12.0	9.0	12	5	14.5	E384M16X1.5
18	1.50	110	24	14.0	11.0	14	5	16.5	E384M18X1.5
20	1.50	125	24	16.0	12.0	15	5	18.5	E384M20X1.5

E011

- MF Maschi a macchina imbocco corretto
- MF Maschinen-Gewindebohrer, geradegenutet mit Schälanschnitt
- MF Machinetap met schilaansnijding
- MF Tarauds machine Coupe gun

Fornito in HSS-E fino a nuovo stock
 Lieferung in HSS-E bis neuer Lagerbestand verfügbar ist
 Geleverd in HSS-E tot de nieuwe voorraad beschikbaar is
 Fourni en HSS-E jusqu'à ce que le nouveau stock soit disponible

E011	▪	1.1	1.2	1.3	1.4	1.5				
	•	1.6	2.1	2.2	2.3	3.1	3.2	3.3	3.4	

E011 MF ISO 529 6H 2.5XD HSS-E PM B 3.5-5 ST

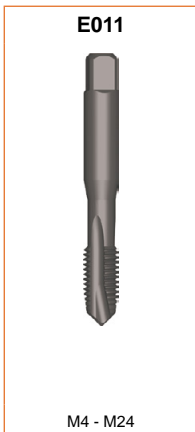
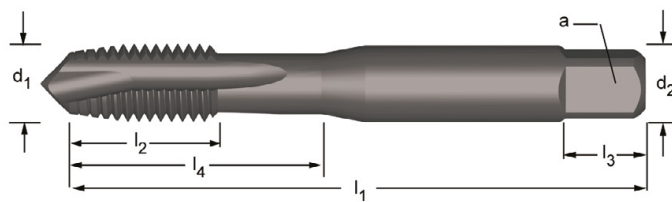

MF	P mm	l ₁ mm	l ₂ mm	d ₂ Ø mm	∠ a mm	l ₃ mm	z	↔	l ₄ mm	E011
4	0.50	53	17	4.0	3.15	6	3	3.5	17	E011M4X.5
5	0.50	58	11	5.0	4.00	7	3	4.5	22	E011M5X.5
6	0.50	66	13	6.3	5.00	8	3	5.5	26	E011M6X.5
6	0.75	66	13	6.3	5.00	8	3	5.3	26	E011M6X.75
8	0.75	72	16	8.0	6.30	9	3	7.3	29	E011M8X.75
8	1.00	72	16	8.0	6.30	9	3	7.0	29	E011M8X1.0
10	1.00	80	18	10.0	8.00	11	3	9.0	34	E011M10X1.0
10	1.25	80	18	10.0	8.00	11	3	8.8	34	E011M10X1.25
12	1.00	89	22	9.0	7.10	10	3	11.0	-	E011M12X1.0
12	1.25	89	22	9.0	7.10	10	3	10.8	-	E011M12X1.25
12	1.50	89	22	9.0	7.10	10	3	10.5	-	E011M12X1.5
14	1.00	95	24	11.2	9.00	12	3	13.0	-	E011M14X1.0
14	1.25	95	24	11.2	9.00	12	3	12.8	-	E011M14X1.25
14	1.50	95	24	11.2	9.00	12	3	12.5	-	E011M14X1.5
16	1.00	102	24	12.5	10.00	13	3	15.0	-	E011M16X1.0
16	1.50	102	24	12.5	10.00	13	3	14.5	-	E011M16X1.5
18	1.00	112	29	14.0	11.20	14	4	17.0	-	E011M18X1.0
18	1.50	112	29	14.0	11.20	14	4	16.5	-	E011M18X1.5
20	1.00	112	29	14.0	11.20	14	4	19.0	-	E011M20X1.0
20	1.50	112	29	14.0	11.20	14	4	18.5	-	E011M20X1.5
20	2.00	112	29	14.0	11.20	14	4	18.0	-	E011M20X2.0
22	1.50	118	29	16.0	12.50	16	4	20.5	-	E011M22X1.5
24	1.50	130	35	18.0	14.00	18	4	22.5	-	E011M24X1.5
24	2.00	130	35	18.0	14.00	18	4	22.0	-	E011M24X2.0

EX10 EX10TIN EX11

- MF Maschi a macchina Scanalature elicoidali 45°
- MF Maschinen-Gewindebohrer, rechtsgedrallte Nuten 45°
- MF Machinetap met gespiraliseerde spaangroeven 45°
- MF Tarauds machine goujures hélicoidales 45°

Fornito in HSS-E fino a nuovo stock

Lieferung in HSS-E bis neuer Lagerbestand verfügbar ist

Geleverd in HSS-E tot de nieuwe voorraad beschikbaar is

Fourni en HSS-E jusqu'à ce que le nouveau stock soit disponible

EX10	▪	1.1	1.2	1.3	1.4	1.5	7.1	7.2	7.3	7.4
	•	4.1	4.2	5.1	5.2					
EX10TIN	▪	1.1	1.2	1.3	1.4	1.5	2.1	2.2	7.3	7.4
	•	2.3	3.1	3.2	3.3	3.4	4.1	4.2	5.1	5.2
EX11	▪	1.1	1.2	1.3	1.4	1.5	2.1	2.2		
	•	2.3								

EX10	MF	DIN 374	6H		2.5XD	HSS-E PM	C 2-3				
EX10TIN	MF	DIN 374	6H		2.5XD	HSS-E PM	C 2-3				
EX11	MF	DIN 374	6H		2.5XD	HSS-E PM	C 2-3				

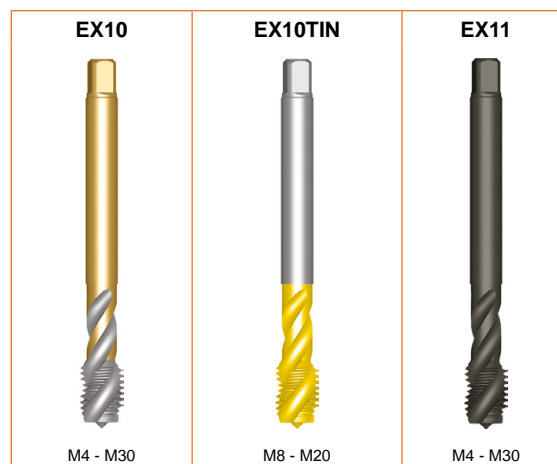
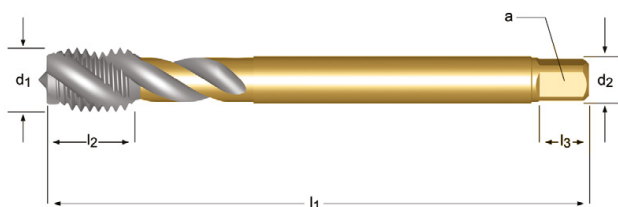

MF	P mm	l ₁ mm	l ₂ mm	d ₂ Ø mm	□ a mm	l ₃ mm	z		EX10	EX10TIN	EX11
4	0.50	63	7	2.8	2.1	5	3	3.5	EX10M4X.50		EX11M4X.50
5	0.50	70	8	3.5	2.7	6	3	4.5	EX10M5X.50		EX11M5X.50
6	0.75	80	10	4.5	3.4	6	3	5.3	EX10M6X.75		EX11M6X.75
8	0.75	80	13	6.0	4.9	8	3	7.3	EX10M8X.75		EX11M8X.75
8	1.00	90	13	6.0	4.9	8	3	7	EX10M8X1.0	EX10TINM8X1.0	EX11M8X1.0
10	0.75	90	13	7.0	5.5	8	3	9.3	EX10M10X.75		EX11M10X.75
10	1.00	90	13	7.0	5.5	8	3	9	EX10M10X1.0	EX10TINM10X1.0	EX11M10X1.0
10	1.25	100	15	7.0	5.5	8	3	8.8	EX10M10X1.25	EX10TINM10X1.25	EX11M10X1.25
12	1.00	100	15	9.0	7.0	10	3	11	EX10M12X1.0	EX10TINM12X1.0	EX11M12X1.0
12	1.25	100	15	9.0	7.0	10	3	10.8	EX10M12X1.25	EX10TINM12X1.25	EX11M12X1.25
12	1.50	100	15	9.0	7.0	10	3	10.5	EX10M12X1.5	EX10TINM12X1.5	EX11M12X1.5
14	1.00	100	15	11.0	9.0	12	3	13	EX10M14X1.0		EX11M14X1.0
14	1.25	100	15	11.0	9.0	12	3	12.8	EX10M14X1.25		EX11M14X1.25
14	1.50	100	15	11.0	9.0	12	3	12.5	EX10M14X1.5	EX10TINM14X1.5	EX11M14X1.5
16	1.00	100	15	12.0	9.0	12	4	15	EX10M16X1.0		EX11M16X1.0
16	1.50	100	15	12.0	9.0	12	4	14.5	EX10M16X1.5	EX10TINM16X1.5	EX11M16X1.5
18	1.00	110	17	14.0	11.0	14	4	17	EX10M18X1.0		EX11M18X1.0
18	1.50	110	17	14.0	11.0	14	4	16.5	EX10M18X1.5	EX10TINM18X1.5	EX11M18X1.5

MF	P mm	l ₁ mm	l ₂ mm	d ₂ ∅ mm	□ a mm	l ₃ mm	z		EX10	EX10TIN	EX11
20	1.00	125	17	16.0	12.0	15	4	19	EX10M20X1.0		EX11M20X1.0
20	1.50	125	17	16.0	12.0	15	4	18.5	EX10M20X1.5	EX10TINM20X1.5	EX11M20X1.5
22	1.50	125	17	18.0	14.5	17	4	20.5	EX10M22X1.5		EX11M22X1.5
24	1.50	140	20	18.0	14.5	17	4	22.5	EX10M24X1.5		EX11M24X1.5
24	2.00	140	20	18.0	14.5	17	4	22	EX10M24X2.0		EX11M24X2.0
25	1.50	140	20	18.0	14.5	17	4	23.5	EX10M25X1.5		EX11M25X1.5
26	1.50	140	20	18.0	14.5	17	4	24.5	EX10M26X1.5		EX11M26X1.5
27	1.50	140	20	20.0	16.0	19	4	25.5	EX10M27X1.5		EX11M27X1.5
27	2.00	140	20	20.0	16.0	19	4	25	EX10M27X2.0		EX11M27X2.0
28	1.50	140	20	20.0	16.0	19	4	26.5	EX10M28X1.5		EX11M28X1.5
30	1.50	150	20	22.0	18.0	21	4	28.5	EX10M30X1.5		EX11M30X1.5
30	2.00	150	20	22.0	18.0	21	4	28	EX10M30X2.0		EX11M30X2.0

- E300**
- MF Maschi a macchina Scanalature elicoidali 40° , Yellow Shark
 - MF Maschinen-Gewindebohrer, rechtsgedrallte Nuten 40°, Gelbring Shark
 - MF Machinetap met gespiraliseerde spaangroeven 40°, Geelring Shark
 - MF Tarauds machine goujures hélicoïdales 40° , Shark bague jaune

E300 ■ 1.1 1.2 1.3 6.1 6.3
 • 1.4 1.5 6.2

E300 MF DIN 374 6H 2XD HSS-E PM C 2-3 λ40° Cr

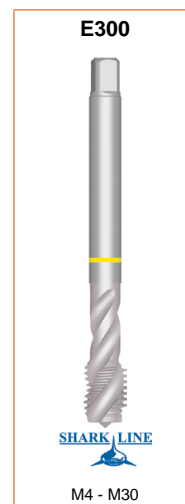
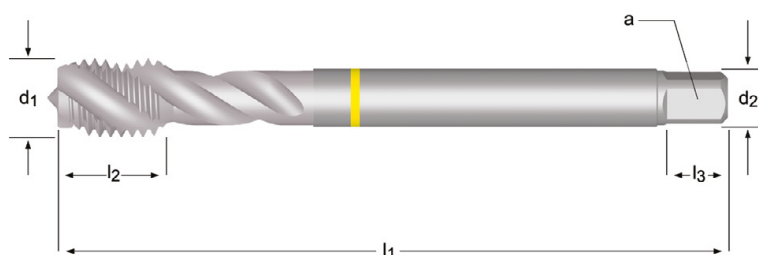

MF	P mm	l ₁ mm	l ₂ mm	d ₂ Ø mm	∠ a mm	l ₃ mm	z	↔	E300
4	0.50	63	6.5	2.8	2.1	5	3	3.5	E300M4X.5
5	0.50	70	7.5	3.5	2.7	6	3	4.5	E300M5X.5
6	0.75	80	10	4.5	3.4	6	3	5.3	E300M6X.75
8	0.75	80	13	6.0	4.9	8	3	7.3	E300M8X.75
8	1.00	90	13	6.0	4.9	8	3	7.0	E300M8X1.0
10	0.75	90	13	7.0	5.5	8	3	9.3	E300M10X.75
10	1.00	90	12	7.0	5.5	8	3	9.0	E300M10X1.0
10	1.25	100	15	7.0	5.5	8	3	8.8	E300M10X1.25
12	1.00	100	15	9.0	7.0	10	4	11.0	E300M12X1.0
12	1.25	100	13	9.0	7.0	10	4	10.8	E300M12X1.25
12	1.50	100	13	9.0	7.0	10	4	10.5	E300M12X1.5
14	1.00	100	15	11.0	9.0	12	4	13.0	E300M14X1.0
14	1.25	100	15	11.0	9.0	12	4	12.8	E300M14X1.25
14	1.50	100	15	11.0	9.0	12	4	12.5	E300M14X1.5
16	1.00	100	15	12.0	9.0	12	5	15.0	E300M16X1.0
16	1.50	100	15	12.0	9.0	12	5	14.5	E300M16X1.5
18	1.00	110	17	14.0	11.0	14	5	17.0	E300M18X1.0
18	1.50	110	17	14.0	11.0	14	5	16.5	E300M18X1.5
20	1.50	125	17	16.0	12.0	15	5	18.5	E300M20X1.5
22	1.50	125	17	18.0	14.5	17	5	20.5	E300M22X1.5
24	1.50	140	20	18.0	14.5	17	5	22.5	E300M24X1.5
24	2.00	140	20	18.0	14.5	17	5	22.0	E300M24X2.0
27	2.00	140	20	20.0	16.0	19	5	25.0	E300M27X2.0
30	2.00	150	20	22.0	18.0	21	5	28.0	E300M30X2.0

- E383**
- MF Maschi a macchina Scanalature elicoidali 40°, Blue Shark
 - MF Maschinen-Gewindebohrer, rechtsgedrahte Nuten 40°, Blauring Shark
 - MF Machinetap, spiraalgroeven 40°, Blauring Shark
 - MF Tarauds machine goujures hélicoïdales 40°, Shark bague bleue

E383 ■ 2.1 2.2 2.3
 • 1.5

E383 MF DIN 374 6H 2XD HSS-E PM C 2-3 λ40° ST

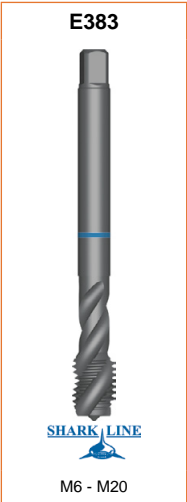
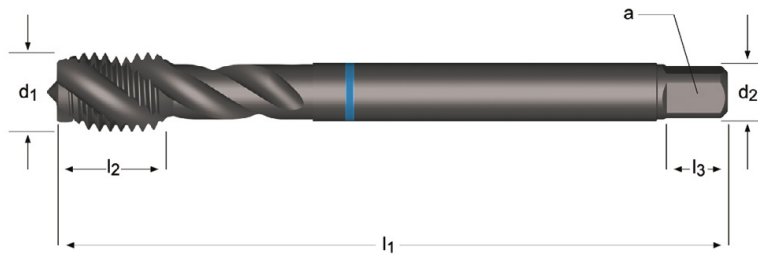

MF	P mm	l ₁ mm	l ₂ mm	d ₂ mm	∠ a mm	l ₃ mm	z		E383
6	0.75	80	10	4.5	3.4	6	3	5.3	E383M6X.75
8	1.00	90	13	6.0	4.9	8	3	7.0	E383M8X1.0
10	1.00	90	12	7.0	5.5	8	3	9.0	E383M10X1.0
10	1.25	100	15	7.0	5.5	8	3	8.8	E383M10X1.25
12	1.00	100	13	9.0	7.0	10	4	11.0	E383M12X1.0
12	1.25	100	13	9.0	7.0	10	4	10.8	E383M12X1.25
12	1.50	100	13	9.0	7.0	10	4	10.5	E383M12X1.5
14	1.50	100	21	11.0	9.0	12	4	12.5	E383M14X1.5
16	1.50	100	21	12.0	9.0	12	5	14.5	E383M16X1.5
18	1.50	110	24	14.0	11.0	14	5	16.5	E383M18X1.5
20	1.50	125	24	16.0	12.0	15	5	18.5	E383M20X1.5

E013

- MF Maschi a macchina Scanalature elicoidali 45°
- MF Maschinen-Gewindebohrer, rechtsgedrallte Nuten 45°
- MF Machinetap met gespiraliseerde spaangroeven 45°
- MF Tarauds machine goujures hélicoïdales 45°

Fornito in HSS-E fino a nuovo stock
 Lieferung in HSS-E bis neuer Lagerbestand verfügbar ist
 Geleverd in HSS-E tot de nieuwe voorraad beschikbaar is
 Fourni en HSS-E jusqu'à ce que le nouveau stock soit disponible

E013 ■ 1.1 1.2 1.3 1.4 1.5
 • 2.1 2.2 2.3

E013 MF ISO 529 6H 2.5XD HSS-E PM C 2-3 λ45° ST

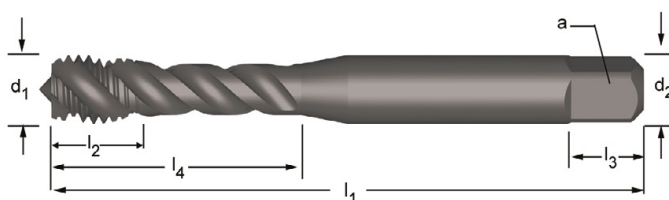

MF	P mm	l ₁ mm	l ₂ mm	d ₂ Ø mm	□ a mm	l ₃ mm	z	↔	l ₄ mm	E013
4	0.50	53	7	4.0	3.15	6	3	3.5	19	E013M4X.5
5	0.50	58	8	5.0	4.0	7	3	4.5	22	E013M5X.5
6	0.50	66	10	6.3	5.0	8	3	5.5	27	E013M6X.5
6	0.75	66	10	6.3	5.0	8	3	5.3	27	E013M6X.75
8	0.75	72	12	8.0	6.3	9	3	7.3	31	E013M8X.75
8	1.00	72	12	8.0	6.3	9	3	7.0	31	E013M8X1.0
10	1.00	80	15	10.0	8.0	11	3	9.0	35	E013M10X1.0
10	1.25	80	15	10.0	8.0	11	3	8.8	35	E013M10X1.25
12	1.00	89	16	9.0	7.1	10	3	11.0	-	E013M12X1.0
12	1.25	89	16	9.0	7.1	10	3	10.8	-	E013M12X1.25
12	1.50	89	16	9.0	7.1	10	3	10.5	-	E013M12X1.5
14	1.50	95	18	11.2	9.0	12	3	12.5	-	E013M14X1.5
16	1.00	102	18	12.5	10.0	13	4	15.0	-	E013M16X1.0
16	1.50	102	18	12.5	10.0	13	4	14.5	-	E013M16X1.5
18	1.50	112	29	14.0	11.2	14	4	16.5	-	E013M18X1.5
20	1.50	112	29	14.0	11.2	14	4	18.5	-	E013M20X1.5
22	1.50	118	29	16.0	12.5	16	4	20.5	-	E013M22X1.5

- E288**
- MF Maschi a rullare
 - MF Maschinen-Gewindeformer
 - MF Machineroltap
 - MF Taraulds machine par Déformation

E288	▪	1.1	1.2	1.3	1.4	2.1	2.2	4.1	5.1	7.1	7.2	7.3
	•	1.5	2.3	5.2	6.1	6.3	7.4					

E288 MF DIN 2174 6HX 3XD HSS-E C 2-3.5

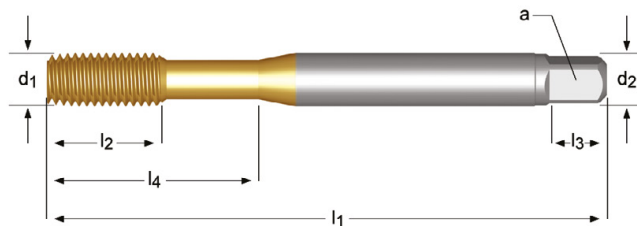

MF	P mm	l ₁ mm	l ₂ mm	d ₂ ∅ mm	a mm	l ₃ mm	z		l ₄ mm	E288
5	0.50	70	13	6.0	4.9	8	5	4.8	25	E288M5X.5
6	0.75	80	15	6.0	4.9	8	5	5.7	30	E288M6X.75
8	1.00	90	18	6.0	4.9	8	5	7.5	-	E288M8X1.0
10	1.00	90	20	7.0	5.5	8	5	9.5	-	E288M10X1.0
10	1.25	100	20	7.0	5.5	8	5	9.4	-	E288M10X1.25
12	1.50	100	21	9.0	7.0	10	5	11.3	-	E288M12X1.5

E108

- UNC Maschi a mano Scanalature diritte
- UNC Handgewindebohrer, geradegenutet
- UNC Handtap met rechte spaangroeven
- UNC Taraulds à main Goujures droites

E108 • 1.1 1.2 1.3 1.4 1.5 3.1 3.2 3.3 3.4 6.1 6.2 6.3 6.4 7.2 7.3 7.4 8.2 8.3

E108 **UNC** **DIN 352** **2B**  **1.5XD** **HSS** **C 2-3**    

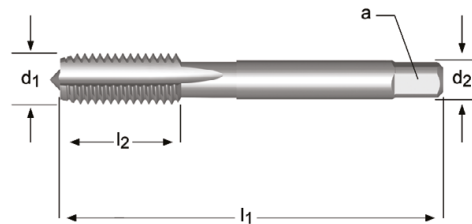

E108



No.5 - 1"

UNC	TPI	d ₁ nom mm	l ₁ mm	l ₂ mm	d ₂ Ø mm	□ a mm	z		E108
5	40	3.18	45	13	4.0	3.0	3	2.65	E1085-40NO3
5	40	3.18	45	13	4.0	3.0	3	2.65	E1085-40NO8
6	32	3.51	45	10	4.0	3.0	3	2.85	E1086-32NO3
6	32	3.51	45	10	4.0	3.0	3	2.85	E1086-32NO8
8	32	4.17	50	14	6.0	4.9	3	3.5	E1088-32NO3
8	32	4.17	50	14	6.0	4.9	3	3.5	E1088-32NO8
10	24	4.83	50	14	6.0	4.9	3	3.9	E10810-24NO3
10	24	4.83	50	14	6.0	4.9	3	3.9	E10810-24NO8
12	24	5.49	56	16	6.0	4.9	3	4.5	E10812-24NO3
12	24	5.49	56	16	6.0	4.9	3	4.5	E10812-24NO8
1/4	20	6.35	56	17	6.0	4.9	3	5.1	E1081/4NO3
1/4	20	6.35	56	17	6.0	4.9	3	5.1	E1081/4NO8
5/16	18	7.94	63	19	6.0	4.9	3	6.6	E1085/16NO3
5/16	18	7.94	63	19	6.0	4.9	3	6.6	E1085/16NO8
3/8	16	9.53	70	22	7.0	5.5	3	8	E1083/8NO3
3/8	16	9.53	70	22	7.0	5.5	3	8	E1083/8NO8
7/16	14	11.11	75	30	8.0	6.2	3	9.4	E1087/16NO3
7/16	14	11.11	75	30	8.0	6.2	3	9.4	E1087/16NO8
1/2	13	12.70	75	27	9.0	7.0	3	10.8	E1081/2NO3
1/2	13	12.70	75	27	9.0	7.0	3	10.8	E1081/2NO8
9/16	12	14.29	80	30	11.0	9.0	4	12.2	E1089/16NO3
9/16	12	14.29	80	30	11.0	9.0	4	12.2	E1089/16NO8
5/8	11	15.88	80	32	12.0	9.0	4	13.5	E1085/8NO3
5/8	11	15.88	80	32	12.0	9.0	4	13.5	E1085/8NO8
3/4	10	19.05	95	34	14.0	11.0	4	16.5	E1083/4NO3
3/4	10	19.05	95	34	14.0	11.0	4	16.5	E1083/4NO8
7/8	9	22.23	110	38	18.0	14.5	4	19.5	E1087/8NO3
7/8	9	22.23	110	38	18.0	14.5	4	19.5	E1087/8NO8
1"	8	25.40	110	38	20.0	16.0	4	22.25	E1081NO8

N01 - N09



219

- E225** • UNC Maschi a macchina Scanalature diritte
 • UNC Maschinen-Gewindebohrer, geradegenutet
- E275** • UNC Machinetap met rechte spaangroeven
 • UNC Tarauds machine Goujures droite

Fornito in HSS-E fino a nuovo stock
 Lieferung in HSS-E bis neuer Lagerbestand verfügbar ist
 Geleverd in HSS-E tot de nieuwe voorraad beschikbaar is
 Fourni en HSS-E jusqu'à ce que le nouveau stock soit disponible

E225; E275 • 1.1 1.2 1.3 1.4 1.5 3.1 3.2 3.3 6.2 6.3 7.2 7.3 8.2

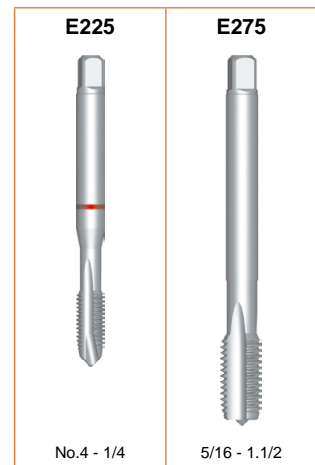
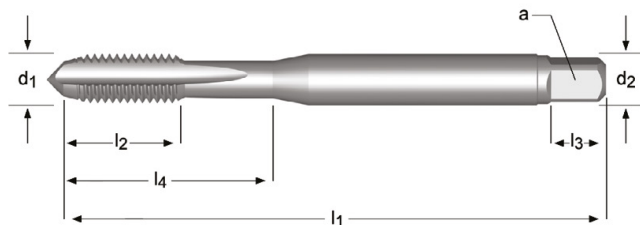

E225	UNC	DIN 371	2B		1.5XD	HSS-E PM	C 2-3				
E275	UNC	DIN 376	2B		1.5XD	HSS-E PM	C 2-3				



UNC	TPI	d ₁ nom mm	l ₁ mm	l ₂ mm	d ₂ Ø mm	a mm	l ₃ mm	z		l ₄ mm	E225	E275
4	40	2.845	56	9	3.5	2.7	6	3	2.35	18	E2254-40	
5	40	3.175	56	10	3.5	2.7	6	3	2.65	18	E2255-40	
6	32	3.505	56	11	4.0	3.0	6	3	2.85	20	E2256-32	
8	32	4.166	63	12	4.5	3.4	8	3	3.5	21	E2258-32	
10	24	4.826	70	13	6.0	4.9	8	3	3.9	25	E22510-24	
12	24	5.486	80	15	6.0	4.9	8	3	4.5	30	E22512-24	
1/4	20	6.350	80	16	7.0	5.5	8	3	5.1	30	E2251/4	
5/16	18	7.94	90	18	6.0	4.9	8	3	6.6			E2755/16
3/8	16	9.53	100	24	7.0	5.5	8	3	8.0			E2753/8
7/16	14	11.11	110	23	9.0	7.0	10	3	9.4			E2757/16
1/2	13	12.7	110	23	9.0	7.0	10	3	10.8			E2751/2
9/16	12	14.29	110	25	11.0	9.0	12	3	12.2			E2759/16
5/8	11	15.88	110	25	12.0	9.0	12	4	13.5			E2755/8
3/4	10	19.05	140	34	14.0	11.0	14	4	16.5			E2753/4
7/8	9	22.23	140	34	18.0	14.5	17	4	19.5			E2757/8
1"	8	25.40	160	38	20.0	16.0	19	4	22.25			E2751
1.1/8	7	28.58	180	45	22.0	18.0	21	4	25.0			E2751.1/8
1.1/4	7	31.75	180	50	25.0	20.0	23	4	28.0			E2751.1/4
1.1/2	6	38.10	200	60	32.0	24.0	27	4	34.0			E2751.1/2

- E515**
- UNC Maschi a macchina Scanalature diritte
 - UNC Maschinen-Gewindebohrer, geradegenutet
 - UNC Hand-/machinetap met rechte spaangroeven
 - UNC Tarauds machine Goujures droite

E515 • 1.1 1.2 1.3 1.4 1.5 3.1 3.2 3.3 3.4 6.1 6.2 6.3 6.4 7.2 7.3 7.4 8.2 8.3

E515 **UNC** **ISO 529** **2B**  **1.5XD** **HSS**      L120 339

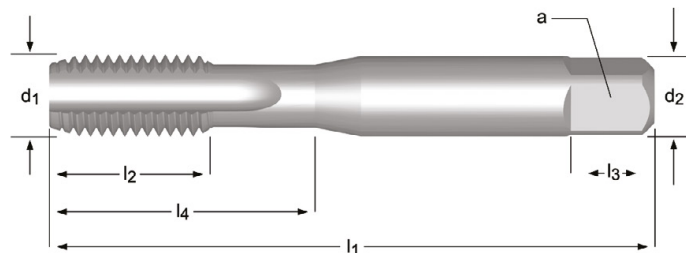

E515



No.1 - 2"

UNC	TPI	d ₁ nom mm	l ₁ mm	l ₂ mm	d ₂ Ø mm	□ a mm	l ₃ mm	z		l ₄ mm	E515
1	64	1.854	41	8	2.50	2.00	4	2	1.55	8	E5151-64NO1
1	64	1.854	41	8	2.50	2.00	4	2	1.55	8	E5151-64NO2
1	64	1.854	41	8	2.50	2.00	4	2	1.55	8	E5151-64NO3
1	64	1.854	41	8	2.50	2.00	4	2	1.55	8	E5151-64NO6
2	56	2.184	44.5	9.5	2.80	2.24	5	3	1.85	9.5	E5152-56NO1
2	56	2.184	44.5	9.5	2.80	2.24	5	3	1.85	9.5	E5152-56NO2
2	56	2.184	44.5	9.5	2.80	2.24	5	3	1.85	9.5	E5152-56NO3
2	56	2.184	44.5	9.5	2.80	2.24	5	3	1.85	9.5	E5152-56NO6
3	48	2.515	44.5	9.5	2.80	2.24	5	3	2.1	9.5	E5153-48NO1
3	48	2.515	44.5	9.5	2.80	2.24	5	3	2.1	9.5	E5153-48NO2
3	48	2.515	44.5	9.5	2.80	2.24	5	3	2.1	9.5	E5153-48NO3
3	48	2.515	44.5	9.5	2.80	2.24	5	3	2.1	9.5	E5153-48NO6
4	40	2.845	48	12.5	3.15	2.50	5	3	2.35	12.5	E5154-40NO1
4	40	2.845	48	12.5	3.15	2.50	5	3	2.35	12.5	E5154-40NO2
4	40	2.845	48	12.5	3.15	2.50	5	3	2.35	12.5	E5154-40NO3
4	40	2.845	48	12.5	3.15	2.50	5	3	2.35	12.5	E5154-40NO6
5	40	3.175	48	12.5	3.15	2.50	5	3	2.65	12.5	E5155-40NO1
5	40	3.175	48	12.5	3.15	2.50	5	3	2.65	12.5	E5155-40NO2
5	40	3.175	48	12.5	3.15	2.50	5	3	2.65	12.5	E5155-40NO3
5	40	3.175	48	12.5	3.15	2.50	5	3	2.65	12.5	E5155-40NO6
6	32	3.505	50	14	3.55	2.80	5	3	2.85	14	E5156-32NO1
6	32	3.505	50	14	3.55	2.80	5	3	2.85	14	E5156-32NO2
6	32	3.505	50	14	3.55	2.80	5	3	2.85	14	E5156-32NO3
6	32	3.505	50	14	3.55	2.80	5	3	2.85	14	E5156-32NO6
8	32	4.166	53	9.5	4.50	3.55	6	3	3.5	17	E5158-32NO1
8	32	4.166	53	9.5	4.50	3.55	6	3	3.5	17	E5158-32NO2
8	32	4.166	53	9.5	4.50	3.55	6	3	3.5	17	E5158-32NO3
8	32	4.166	53	9.5	4.50	3.55	6	3	3.5	17	E5158-32NO6
10	24	4.826	58	11	5.00	4.00	7	3	3.9	20	E51510-24NO1
10	24	4.826	58	11	5.00	4.00	7	3	3.9	20	E51510-24NO2
10	24	4.826	58	11	5.00	4.00	7	3	3.9	20	E51510-24NO3
10	24	4.826	58	11	5.00	4.00	7	3	3.9	20	E51510-24NO6
12	24	5.486	62	12	5.60	4.50	7	3	4.5	21	E51512-24NO1
12	24	5.486	62	12	5.60	4.50	7	3	4.5	21	E51512-24NO2
12	24	5.486	62	12	5.60	4.50	7	3	4.5	21	E51512-24NO3
12	24	5.486	62	12	5.60	4.50	7	3	4.5	21	E51512-24NO6
1/4	20	6.350	66	13	6.30	5.00	8	3	5.1	26	E5151/4NO1
1/4	20	6.350	66	13	6.30	5.00	8	3	5.1	26	E5151/4NO2
1/4	20	6.350	66	13	6.30	5.00	8	3	5.1	26	E5151/4NO3
1/4	20	6.350	66	13	6.30	5.00	8	3	5.1	26	E5151/4NO6
5/16	18	7.938	72	16	8.00	6.30	9	3	6.6	29	E5155/16NO1
5/16	18	7.938	72	16	8.00	6.30	9	3	6.6	29	E5155/16NO2

NO1 - NO9
219

UNC	TPI	d ₁ nom mm	l ₁ mm	l ₂ mm	d ₂ ∅ mm	∠ a mm	l ₃ mm	z		l ₄ mm	E515
5/16	18	7.938	72	16	8.00	6.30	9	3	6.6	29	E5155/16NO3
5/16	18	7.938	72	16	8.00	6.30	9	3	6.6	29	E5155/16NO6
3/8	16	9.525	80	18	10.00	8.00	11	3	8	32	E5153/8NO1
3/8	16	9.525	80	18	10.00	8.00	11	3	8	32	E5153/8NO2
3/8	16	9.525	80	18	10.00	8.00	11	3	8	32	E5153/8NO3
3/8	16	9.525	80	18	10.00	8.00	11	3	8	32	E5153/8NO6
7/16	14	11.112	85	19	8.00	6.30	9	3	9.4	-	E5157/16NO1
7/16	14	11.112	85	19	8.00	6.30	9	3	9.4	-	E5157/16NO2
7/16	14	11.112	85	19	8.00	6.30	9	3	9.4	-	E5157/16NO3
7/16	14	11.112	85	19	8.00	6.30	9	3	9.4	-	E5157/16NO6
1/2	13	12.700	89	22	9.00	7.10	10	3	10.8	-	E5151/2NO1
1/2	13	12.700	89	22	9.00	7.10	10	3	10.8	-	E5151/2NO2
1/2	13	12.700	89	22	9.00	7.10	10	3	10.8	-	E5151/2NO3
1/2	13	12.700	89	22	9.00	7.10	10	3	10.8	-	E5151/2NO6
9/16	12	14.288	95	24	11.20	9.00	12	4	12.2	-	E5159/16NO1
9/16	12	14.288	95	24	11.20	9.00	12	4	12.2	-	E5159/16NO2
9/16	12	14.288	95	24	11.20	9.00	12	4	12.2	-	E5159/16NO3
9/16	12	14.288	95	24	11.20	9.00	12	4	12.2	-	E5159/16NO6
5/8	11	15.875	102	24	12.50	10.00	13	4	13.5	-	E5155/8NO1
5/8	11	15.875	102	24	12.50	10.00	13	4	13.5	-	E5155/8NO2
5/8	11	15.875	102	24	12.50	10.00	13	4	13.5	-	E5155/8NO3
5/8	11	15.875	102	24	12.50	10.00	13	4	13.5	-	E5155/8NO6
3/4	10	19.050	112	29	14.00	11.20	14	4	16.5	-	E5153/4NO1
3/4	10	19.050	112	29	14.00	11.20	14	4	16.5	-	E5153/4NO2
3/4	10	19.050	112	29	14.00	11.20	14	4	16.5	-	E5153/4NO3
3/4	10	19.050	112	29	14.00	11.20	14	4	16.5	-	E5153/4NO6
7/8	9	22.225	118	29	16.00	12.50	16	4	19.5	-	E5157/8NO1
7/8	9	22.225	118	29	16.00	12.50	16	4	19.5	-	E5157/8NO2
7/8	9	22.225	118	29	16.00	12.50	16	4	19.5	-	E5157/8NO3
7/8	9	22.225	118	29	16.00	12.50	16	4	19.5	-	E5157/8NO6
1"	8	25.400	130	35	18.00	14.00	18	4	22.25	-	E5151NO3
1"	8	25.400	130	35	18.00	14.00	18	4	22.25	-	E5151NO1
1"	8	25.400	130	35	18.00	14.00	18	4	22.25	-	E5151NO2
1"	8	25.400	130	35	18.00	14.00	18	4	22.25	-	E5151NO6
1.1/8	7	28.575	138	35	20.00	16.00	20	4	25	-	E5151.1/8NO1
1.1/8	7	28.575	138	35	20.00	16.00	20	4	25	-	E5151.1/8NO2
1.1/8	7	28.575	138	35	20.00	16.00	20	4	25	-	E5151.1/8NO3
1.1/4	7	31.750	151	41	22.40	18.00	22	4	28	-	E5151.1/4NO1
1.1/4	7	31.750	151	41	22.40	18.00	22	4	28	-	E5151.1/4NO2
1.1/4	7	31.750	151	41	22.40	18.00	22	4	28	-	E5151.1/4NO3
1.3/8	6	34.925	162	47	25.00	20.00	24	4	30.75	-	E5151.3/8NO1
1.3/8	6	34.925	162	47	25.00	20.00	24	4	30.75	-	E5151.3/8NO2
1.3/8	6	34.925	162	47	25.00	20.00	24	4	30.75	-	E5151.3/8NO3
1.1/2	6	38.100	170	47	28.00	22.40	26	4	34	-	E5151.1/2NO1
1.1/2	6	38.100	170	47	28.00	22.40	26	4	34	-	E5151.1/2NO2
1.1/2	6	38.100	170	47	28.00	22.40	26	4	34	-	E5151.1/2NO3
1.3/4	5	44.450	187	54	31.50	25.00	28	6	39.5	-	E5151.3/4NO1
1.3/4	5	44.450	187	54	31.50	25.00	28	6	39.5	-	E5151.3/4NO2
1.3/4	5	44.450	187	54	31.50	25.00	28	6	39.5	-	E5151.3/4NO3
2"	4.5	50.800	200	60	35.50	28.00	31	6	45	-	E5152NO3
2"	4.5	50.800	200	60	35.50	28.00	31	6	45	-	E5152NO1
2"	4.5	50.800	200	60	35.50	28.00	31	6	45	-	E5152NO2

NO1 - NO9











219

EP20 • UNC Maschi a macchina imbocco corretto
 • UNC Maschinen-Gewindebohrer, geradegenutet mit Schälanschnitt

EP21 • UNC Machinetap met schilaansnijding
 • UNC Tarauds machine Coupe gun

Fornito in HSS-E fino a nuovo stock
 Lieferung in HSS-E bis neuer Lagerbestand verfügbar ist
 Geleverd in HSS-E tot de nieuwe voorraad beschikbaar is
 Fourni en HSS-E jusqu'à ce que le nouveau stock soit disponible

EP20	▪	1.1	1.2	1.3	1.4	1.5	6.1	6.3	7.1	7.2	7.3	7.4
	•	1.6	3.1	3.2	3.3	3.4	4.1	4.2	5.1	5.2	6.2	8.1
EP21	▪	1.1	1.2	1.3	1.4	1.5						
	•	1.6	2.1	2.2	2.3	3.1	3.2	3.3	3.4			

EP20	UNC	DIN 2184-1	2B		2.5XD	HSS-E PM	B 3.5-5				
EP21	UNC	DIN 2184-1	2B		2.5XD	HSS-E PM	B 3.5-5			 ST	

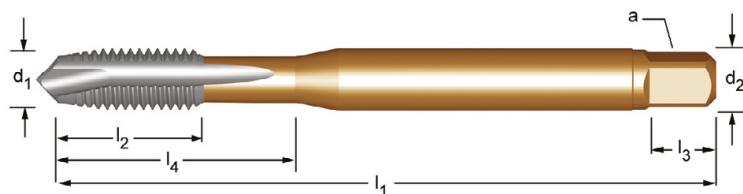

UNC	TPI	d ₁ nom mm	l ₁ mm	l ₂ mm	d ₂ Ø mm	a mm	l ₃ mm	z		l ₄ mm	EP20	EP21
4	40	2.845	56	9	3.5	2.7	6	3	2.35	18	EP204-40	EP214-40
5	40	3.175	56	10	3.5	2.7	6	3	2.65	18	EP205-40	EP215-40
6	32	3.505	56	11	4.0	3.0	6	3	2.85	20	EP206-32	EP216-32
8	32	4.166	63	12	4.5	3.4	8	3	3.5	21	EP208-32	EP218-32
10	24	4.826	70	13	6.0	4.9	8	3	3.9	25	EP210-24	EP2110-24
12	24	5.486	80	15	6.0	4.9	8	3	4.5	30	EP212-24	EP2112-24
1/4	20	6.350	80	15	7.0	5.5	8	3	5.1	30	EP201/4	EP211/4
5/16	18	7.938	90	18	8.0	6.2	9	3	6.6	35	EP205/16	EP215/16
3/8	16	9.525	100	20	10.0	8.0	11	3	8	39	EP203/8	EP213/8
7/16	14	11.112	100	20	8.0	6.2	9	3	9.4	-	EP207/16	EP217/16
1/2	13	12.700	110	23	9.0	7.0	10	3	10.8	-	EP201/2	EP211/2
5/8	11	15.875	110	25	12.0	9.0	12	3	13.5	-	EP205/8	EP215/8
3/4	10	19.050	125	30	14.0	11.0	14	4	16.5	-	EP203/4	EP213/4
7/8	9	22.225	140	34	18.0	14.5	17	4	19.5	-	EP207/8	EP217/8
1"	8	25.400	160	38	18.0	14.5	17	4	22.25	-	EP201	EP211

E021

- UNC Maschi a macchina imbocco corretto
- UNC Maschinen-Gewindebohrer, geradegenutet mit Schälanschnitt
- UNC Machinetap met schilaansnijding
- UNC Tarauds machine Coupe gun

Fornito in HSS-E fino a nuovo stock
 Lieferung in HSS-E bis neuer Lagerbestand verfügbar ist
 Geleverd in HSS-E tot de nieuwe voorraad beschikbaar is
 Fourni en HSS-E jusqu'à ce que le nouveau stock soit disponible

E021	▪	1.1	1.2	1.3	1.4	1.5						
	•	1.6	2.1	2.2	2.3	3.1	3.2	3.3	3.4			

E021 **UNC** **ISO 529** **2B** **HSS-E PM** **B 3.5-5**

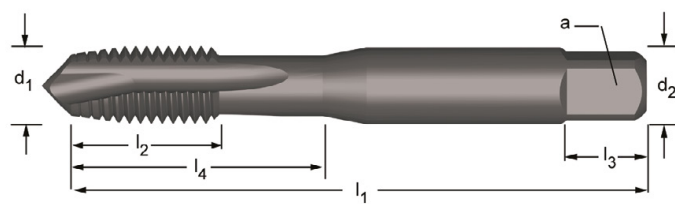

UNC	TPI	d ₁ nom mm	l ₁ mm	l ₂ mm	d ₂ Ø mm	∠ a mm	l ₃ mm	z		l ₄ mm	E021
2	56	2.184	44.5	9.5	2.80	2.24	5	2	1.85	9.5	E0212-56
4	40	2.845	48	14	3.15	2.50	5	3	2.35	14	E0214-40
5	40	3.175	48	12.5	3.15	2.50	5	3	2.65	12.5	E0215-40
6	32	3.505	50	16	3.55	2.80	5	3	2.85	16	E0216-32
8	32	4.166	53	9.5	4.50	3.55	6	3	3.50	17	E0218-32
10	24	4.826	58	11	5.00	4.00	7	3	3.90	20	E02110-24
12	24	5.486	62	12	5.60	4.50	7	3	4.50	21	E02112-24
1/4	20	6.350	66	13	6.30	5.00	8	3	5.10	26	E0211/4
5/16	18	7.938	72	16	8.00	6.30	9	3	6.60	29	E0215/16
3/8	16	9.525	80	18	10.00	8.00	11	3	8.00	32	E0213/8
7/16	14	11.112	85	19	8.00	6.30	9	3	9.40	-	E0217/16
1/2	13	12.700	89	22	9.00	7.10	10	3	10.80	-	E0211/2
5/8	11	15.875	102	24	12.50	10.00	13	3	13.50	-	E0215/8
3/4	10	19.050	112	29	14.00	11.20	14	4	16.50	-	E0213/4
7/8	9	22.225	118	29	16.00	12.50	16	4	19.50	-	E0217/8
1"	8	25.400	130	35	18.00	14.00	18	4	22.25	-	E0211

- EX20**
- UNC Maschi a macchina Scanalature elicoidali 45°
 - UNC Maschinen-Gewindebohrer, rechtsgedrallte Nuten 45°
- EX21**
- UNC Machinetap met gespiraliseerde spaangroeven 45°
 - UNC Tarauds machine goujures hélicoïdales 45°

Fornito in HSS-E fino a nuovo stock
 Lieferung in HSS-E bis neuer Lagerbestand verfügbar ist
 Geleverd in HSS-E tot de nieuwe voorraad beschikbaar is
 Fourni en HSS-E jusqu'à ce que le nouveau stock soit disponible

EX20 ■ 1.1 1.2 1.3 1.4 1.5 7.1 7.2 7.3 7.4

• 4.1 4.2 5.1 5.2

EX21 ■ 1.1 1.2 1.3 1.4 1.5 2.1 2.2

• 2.3

EX20	UNC	DIN 2184-1	2B		2.5XD	HSS-E PM	C 2-3		$\lambda 45^\circ$			
EX21	UNC	DIN 2184-1	2B		2.5XD	HSS-E PM	C 2-3		$\lambda 45^\circ$		ST	

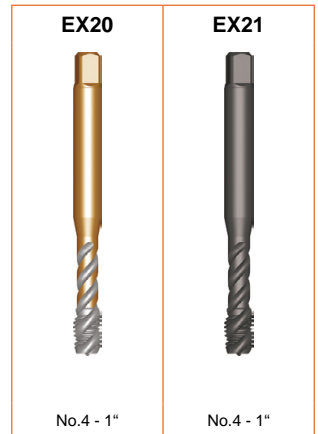
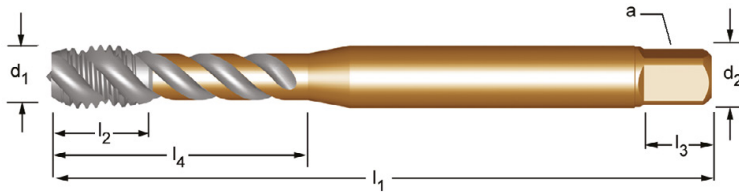

UNC	TPI	d ₁ nom mm	l ₁ mm	l ₂ mm	d ₂ Ø mm	a mm	l ₃ mm	z		l ₄ mm	EX20	EX21
4	40	2.845	56	6	3.5	2.7	6	3	2.35	18	EX204-40	EX214-40
5	40	3.175	56	6	3.5	2.7	6	3	2.65	18	EX205-40	EX215-40
6	32	3.505	56	7	4.0	3.0	6	3	2.85	20	EX206-32	EX216-32
8	32	4.166	63	7	4.5	3.4	8	3	3.5	21	EX208-32	EX218-32
10	24	4.826	70	8	6.0	4.9	8	3	3.9	25	EX2010-24	EX2110-24
12	24	5.486	80	10	6.0	4.9	8	3	4.5	30	EX2012-24	EX2112-24
1/4	20	6.350	80	10	7.0	5.5	8	3	5.1	30	EX201/4	EX211/4
5/16	18	7.938	90	12	8.0	6.2	9	3	6.6	35	EX205/16	EX215/16
3/8	16	9.525	100	15	10.0	8.0	11	3	8.0	39	EX203/8	EX213/8
7/16	14	11.112	100	15	8.0	6.2	9	3	9.4	-	EX207/16	EX217/16
1/2	13	12.700	110	18	9.0	7.0	10	3	10.8	-	EX201/2	EX211/2
5/8	11	15.875	110	20	12.0	9.0	12	4	13.5	-	EX205/8	EX215/8
3/4	10	19.050	125	25	14.0	11.0	14	4	16.5	-	EX203/4	EX213/4
7/8	9	22.225	140	25	18.0	14.5	17	4	19.5	-	EX207/8	EX217/8
1"	8	25.400	160	30	18.0	14.5	17	4	22.25	-	EX201	EX211

- # E023
- UNC Maschi a macchina Scanalature elicoidali 45°
 - UNC Maschinen-Gewindebohrer, rechtsgedrallte Nuten 45°
 - UNC Machinetap met gespiraliseerde spaangroeven 45°
 - UNC Tarauds machine goujures hélicoïdales 45°

Fornito in HSS-E fino a nuovo stock
 Lieferung in HSS-E bis neuer Lagerbestand verfügbar ist
 Geleverd in HSS-E tot de nieuwe voorraad beschikbaar is
 Fourni en HSS-E jusqu'à ce que le nouveau stock soit disponible

- E023 ■ 1.1 1.2 1.3 1.4 1.5
 • 2.1 2.2 2.3

E023 **UNC** **ISO 529** **2B** **2.5XD** **HSS-E PM** **C 2-3** **λ45°**

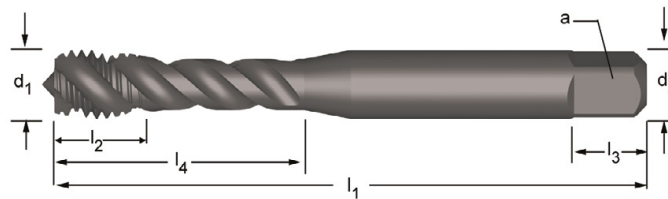

UNC	TPI	d ₁ nom mm	l ₁ mm	l ₂ mm	d ₂ Ø mm	∠ a mm	l ₃ mm	z		l ₄ mm	E023
2	56	2.184	44.5	9.5	2.80	2.24	5	2	1.85	9.5	E0232-56
4	40	2.845	48	6	3.15	2.50	5	3	2.35	14	E0234-40
5	40	3.175	48	6	3.15	2.50	5	3	2.65	12.5	E0235-40
6	32	3.505	50	6	3.55	2.80	5	3	2.85	16	E0236-32
8	32	4.166	53	7	4.50	3.55	6	3	3.50	17	E0238-32
10	24	4.826	58	8	5.00	4.00	7	3	3.90	20	E02310-24
12	24	5.486	62	12	5.60	4.50	7	3	4.50	21	E02312-24
1/4	20	6.350	66	10	6.30	5.00	8	3	5.10	28	E0231/4
5/16	18	7.938	72	12	8.00	6.30	9	3	6.60	31	E0235/16
3/8	16	9.525	80	15	10.00	8.00	11	3	8.00	34	E0233/8
7/16	14	11.112	85	19	8.00	6.30	9	3	9.40	-	E0237/16
1/2	13	12.700	89	19	9.00	7.10	10	3	10.80	-	E0231/2
5/8	11	15.875	102	24	12.50	10.00	13	4	13.50	-	E0235/8
3/4	10	19.050	112	29	14.00	11.20	14	4	16.50	-	E0233/4
7/8	9	22.225	118	29	16.00	12.50	16	4	19.50	-	E0237/8
1"	8	25.400	130	35	18.00	14.00	18	4	22.25	-	E0231

E651

- UNC Punta a maschiare Scanalature elicoidali 30°
- UNC Kombi-Gewindebohrer, rechtsgedrallte Nuten 30°
- UNC Combi boortap met gespiraliseerde spaangroeven 30°
- UNC Foret taraudeur goujures hélicoidales 30°

E651 • 1.1 1.2 1.3 1.4 3.2 6.2 6.3 7.1 7.2 8.1

E651 **UNC**  **2B**  **1.5XD** **HSS** **C**
2-3  **λ 30°**  **ST**

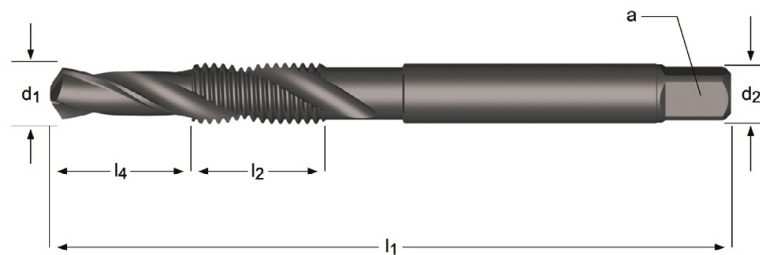

E651



No.6 - 5/8

UNC	TPI	d ₁ nom mm	l ₁ mm	l ₂ mm	l ₄ mm	d ₂ Ø mm	∠ a mm	z	E651
6	32	2.85	56.9	12	6.0	3.50	2.90	2	E6516-32
8	32	3.50	64.0	12	8.0	4.50	3.55	2	E6518-32
10	24	3.90	72.0	15	10.0	5.00	4.00	2	E65110-24
12	24	4.50	77.0	15	11.0	5.60	4.50	2	E65112-24
1/4	20	5.10	83.0	17	13.0	6.30	5.00	2	E6511/4
5/16	18	6.60	94.0	21	16.0	8.00	6.30	2	E6515/16
3/8	16	8.00	107.0	23	19.0	10.00	8.00	2	E6513/8
7/16	14	9.40	107.0	25	22.0	8.00	6.30	2	E6517/16
1/2	13	10.80	114.0	29	25.0	9.00	7.10	2	E6511/2
9/16	12	12.20	124.0	29	28.0	11.20	9.00	2	E6519/16
5/8	11	13.50	134.0	31	32.5	12.50	10.00	2	E6515/8

- E287**
- UNC Maschi a rullare, Canalini di lubrificazione
 - UNC Maschinen-Gewindeformer, Ölnuten / Schmiernuten
 - UNC Machineroltap met smeergroeven
 - UNC Tarauds machine à refoiler, rainures de lubrification

E287	▪	1.1	1.2	1.3	1.4	2.1	2.2	4.1	5.1	7.1	7.2	7.3
	•	1.5	2.3	5.2	6.1	6.3	7.4					

E287 **UNC** **DIN 2184-1** **2BX** **3.5XD** **HSS-E** **C 2-3.5** **TIN**

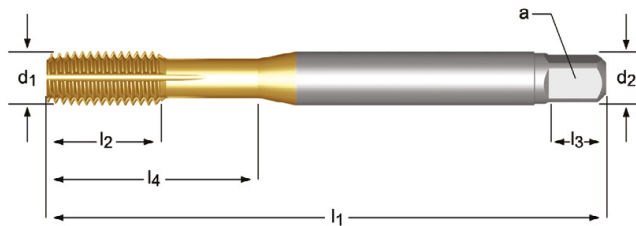

M	TPI	d ₁ nom mm	l ₁ mm	l ₂ mm	d ₂ ∅ mm	□ a mm	l ₃ mm	z		l ₄ mm	E287
4	40	2.845	56	9	3.5	2.7	6	4	2.6	18	E2874-40
6	32	3.505	56	11	4.0	3.0	6	4	3.2	20	E2876-32
8	32	4.166	63	12	4.5	3.4	6	5	3.8	21	E2878-32
10	24	4.826	70	13	6.0	4.9	8	5	4.4	25	E28710-24
1/4	20	6.350	80	15	7.0	5.5	8	5	5.8	30	E2871/4
5/16	18	7.938	90	18	8.0	6.2	9	5	7.3	35	E2875/16
3/8	16	9.525	100	20	10.0	8.0	11	5	8.8	39	E2873/8
7/16	14	11.112	100	20	8.0	6.2	9	5	10.3	-	E2877/16
1/2	13	12.700	110	23	9.0	7.0	10	5	11.9	-	E2871/2

E111

- UNF Maschi a mano Scanalature diritte
- UNF Handgewindebohrer, geradegenutet
- UNF Handtap met rechte spaangroeven
- UNF Tarauds à main Goujures droites

E111 • 1.1 1.2 1.3 1.4 1.5 3.1 3.2 3.3 3.4 6.1 6.2 6.3 6.4 7.2 7.3 7.4 8.2 8.3

E111 UNF DIN 2181 2B 1.5XD HSS C 2-3

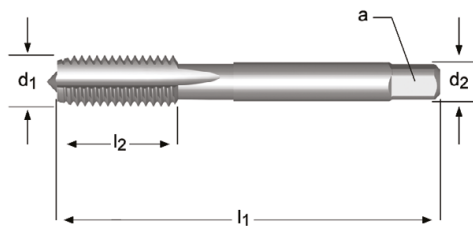

UNF	TPI	d ₁ nom mm	l ₁ mm	l ₂ mm	d ₂ Ø mm	□ a mm	z	↔	E111
5	44	3.18	45	13	4.0	3.0	3	2.7	E1115-44NO3
5	44	3.18	45	13	4.0	3.0	3	2.7	E1115-44NO9
6	40	3.51	45	10	4.0	3.0	3	2.95	E1116-40NO3
6	40	3.51	45	10	4.0	3.0	3	2.95	E1116-40NO9
8	36	4.17	50	14	6.0	4.9	3	3.5	E1118-36NO3
8	36	4.17	50	14	6.0	4.9	3	3.5	E1118-36NO9
10	32	4.82	50	14	6.0	4.9	3	4.1	E11110-32NO3
10	32	4.82	50	14	6.0	4.9	3	4.1	E11110-32NO9
1/4	28	6.35	56	17	6.0	4.9	3	5.5	E1111/4NO3
1/4	28	6.35	56	17	6.0	4.9	3	5.5	E1111/4NO9
5/16	24	7.94	63	19	6.0	4.9	3	6.9	E1115/16NO3
5/16	24	7.94	63	19	6.0	4.9	3	6.9	E1115/16NO9
3/8	24	9.53	63	16	7.0	5.5	3	8.5	E1113/8NO3
3/8	24	9.53	63	16	7.0	5.5	3	8.5	E1113/8NO9
7/16	20	11.11	63	15	8.0	6.2	3	9.9	E1117/16NO3
7/16	20	11.11	63	15	8.0	6.2	3	9.9	E1117/16NO9
1/2	20	12.70	70	22	9.0	7.0	3	11.5	E1111/2NO3
1/2	20	12.70	70	22	9.0	7.0	3	11.5	E1111/2NO9
9/16	18	14.29	70	16	11.0	9.0	4	12.9	E1119/16NO3
9/16	18	14.29	70	16	11.0	9.0	4	12.9	E1119/16NO9
5/8	18	15.88	70	16	12.0	9.0	4	14.5	E1115/8NO3
5/8	18	15.88	70	16	12.0	9.0	4	14.5	E1115/8NO9
3/4	16	19.05	80	22	14.0	11.0	4	17.5	E1113/4NO3
3/4	16	19.05	80	22	14.0	11.0	4	17.5	E1113/4NO9
7/8	14	22.23	90	22	18.0	14.5	4	20.4	E1117/8NO3
7/8	14	22.23	90	22	18.0	14.5	4	20.4	E1117/8NO9
1"	12	25.40	90	22	20.0	16.0	4	23.25	E1111NO3
1"	12	25.40	90	22	20.0	16.0	4	23.25	E1111NO9

NO1 - NO9
219

- E229** • UNF Maschi a macchina Scanalature diritte
 • UNF Maschinen-Gewindebohrer, geradegenutet
- E278** • UNF Machinetap met rechte spaangroeven
 • UNF Tarauds machine Goujures droites

Fornito in HSS-E fino a nuovo stock
 Lieferung in HSS-E bis neuer Lagerbestand verfügbar ist
 Geleverd in HSS-E tot de nieuwe voorraad beschikbaar is
 Fourni en HSS-E jusqu'à ce que le nouveau stock soit disponible

E229; E278 • 1.1 1.2 1.3 1.4 1.5 3.1 3.2 3.3 6.2 6.3 7.2 7.3 8.2

E229	UNF	DIN 371	2B		1.5XD	HSS-E PM	C 2-3				
E278	UNF	DIN 374	2B		1.5XD	HSS-E PM	C 2-3				

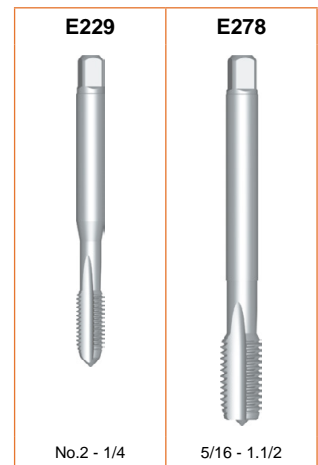
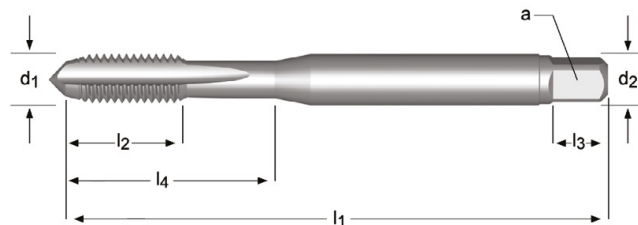

UNF	TPI	d ₁ nom mm	l ₁ mm	l ₂ mm	d ₂ Ø mm	a mm	l ₃ mm	z		l ₄ mm	E229	E278
2	64	2.184	45	7	2.8	2.1	5	3	1.9	12	E2292-64	
3	56	2.515	50	8	2.8	2.1	5	3	2.15	12.5	E2293-56	
4	48	2.845	56	9	3.5	2.7	6	3	2.4	18	E2294-48	
5	44	3.175	56	10	3.5	2.7	6	3	2.7	18	E2295-44	
6	40	3.505	56	11	4.0	3.0	6	3	2.95	20	E2296-40	
8	36	4.166	63	12	4.5	3.4	6	3	3.5	21	E2298-36	
10	32	4.826	70	13	6.0	4.9	8	3	4.1	25	E22910-32	
12	28	5.486	80	15	6.0	4.9	8	3	4.7	30	E22912-28	
1/4	28	6.350	80	15	7.0	5.5	8	3	5.5	30	E2291/4	
5/16	24	7.94	90	18	6.0	4.9	8	3	6.9			E2785/16
3/8	24	9.53	100	24	7.0	5.5	8	3	8.5			E2783/8
7/16	20	11.11	100	22	9.0	7.0	10	3	9.9			E2787/16
1/2	20	12.70	100	21	9.0	7.0	10	3	11.5			E2781/2
9/16	18	14.29	100	21	11.0	9.0	12	4	12.9			E2789/16
5/8	18	15.88	100	21	12.0	9.0	12	4	14.5			E2785/8
3/4	16	19.05	125	25	14.0	11.0	14	4	17.5			E2783/4
7/8	14	22.23	140	28	18.0	14.5	17	4	20.4			E2787/8
1"	12	25.40	140	26	18.0	14.5	17	4	23.25			E2781
1.1/8	12	28.58	150	28	22.0	18.0	21	4	26.5			E2781.1/8
1.1/4	12	31.75	150	28	25.0	20.0	23	4	29.5			E2781.1/4
1.3/8	12	34.93	170	30	28.0	22.0	25	4	32.75			E2781.3/8
1.1/2	12	38.10	170	30	32.0	24.0	27	4	36.0			E2781.1/2 ¹⁾

¹⁾ HSS-E

- E524**
- UNF Maschi a macchina Scanalature dritte
 - UNF Maschinen-Gewindebohrer, geradegenutet
 - UNF Hand-/machinetap met rechte spaangroeven
 - UNF Taraulds machine Goujures droites

E524 • 1.1 1.2 1.3 1.4 1.5 3.1 3.2 3.3 3.4 6.1 6.2 6.3 6.4 7.2 7.3 7.4 8.2 8.3

E524 UNF ISO 529 2B 1.5XD HSS

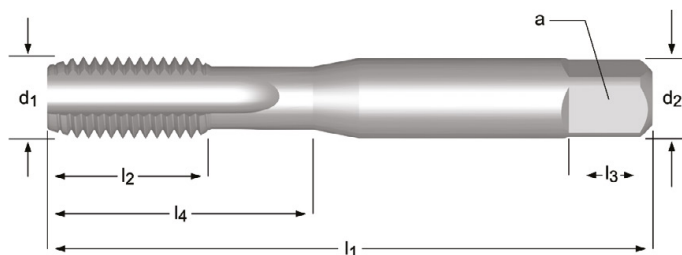

UNF	TPI	d ₁ nom mm	l ₁ mm	l ₂ mm	d ₂ Ø mm	∠ a mm	l ₃ mm	z		l ₄ mm	E524
0	80	1.524	41	7	2.50	2.00	4	2	1.25	7	E5240-80NO1
0	80	1.524	41	7	2.50	2.00	4	2	1.25	7	E5240-80NO2
0	80	1.524	41	7	2.50	2.00	4	2	1.25	7	E5240-80NO3
1	72	1.854	41	8	2.50	2.00	4	2	1.55	8	E5241-72NO1
1	72	1.854	41	8	2.50	2.00	4	2	1.55	8	E5241-72NO2
1	72	1.854	41	8	2.50	2.00	4	2	1.55	8	E5241-72NO3
2	64	2.184	44.5	9.5	2.80	2.24	5	3	1.9	9.5	E5242-64NO1
2	64	2.184	44.5	9.5	2.80	2.24	5	3	1.9	9.5	E5242-64NO2
2	64	2.184	44.5	9.5	2.80	2.24	5	3	1.9	9.5	E5242-64NO3
4	48	2.845	48	12.5	3.15	2.50	5	3	2.4	12.5	E5244-48NO1
4	48	2.845	48	12.5	3.15	2.50	5	3	2.4	12.5	E5244-48NO2
4	48	2.845	48	12.5	3.15	2.50	5	3	2.4	12.5	E5244-48NO3
5	44	3.175	48	12.5	3.15	2.50	5	3	2.7	12.5	E5245-44NO1
5	44	3.175	48	12.5	3.15	2.50	5	3	2.7	12.5	E5245-44NO2
5	44	3.175	48	12.5	3.15	2.50	5	3	2.7	12.5	E5245-44NO3
6	40	3.505	50	14	3.55	2.80	5	3	2.95	14	E5246-40NO1
6	40	3.505	50	14	3.55	2.80	5	3	2.95	14	E5246-40NO2
6	40	3.505	50	14	3.55	2.80	5	3	2.95	14	E5246-40NO3
8	36	4.166	53	9.5	4.50	3.55	6	3	3.5	17	E5248-36NO1
8	36	4.166	53	9.5	4.50	3.55	6	3	3.5	17	E5248-36NO2
8	36	4.166	53	9.5	4.50	3.55	6	3	3.5	17	E5248-36NO3
10	32	4.826	58	11	5.00	4.00	7	3	4.1	20	E52410-32NO1
10	32	4.826	58	11	5.00	4.00	7	3	4.1	20	E52410-32NO2
10	32	4.826	58	11	5.00	4.00	7	3	4.1	20	E52410-32NO3
10	32	4.826	58	11	5.00	4.00	7	3	4.1	20	E52410-32NO6
12	28	5.486	62	12	5.60	4.50	7	3	4.7	21	E52412-28NO1
12	28	5.486	62	12	5.60	4.50	7	3	4.7	21	E52412-28NO2
12	28	5.486	62	12	5.60	4.50	7	3	4.7	21	E52412-28NO3
12	28	5.486	62	12	5.60	4.50	7	3	4.7	21	E52412-28NO6
1/4	28	6.350	66	13	6.30	5.00	8	3	5.5	26	E5241/4NO1
1/4	28	6.350	66	13	6.30	5.00	8	3	5.5	26	E5241/4NO2
1/4	28	6.350	66	13	6.30	5.00	8	3	5.5	26	E5241/4NO3
1/4	28	6.350	66	13	6.30	5.00	8	3	5.5	26	E5241/4NO6
5/16	24	7.938	72	16	8.00	6.30	9	3	6.9	29	E5245/16NO1
5/16	24	7.938	72	16	8.00	6.30	9	3	6.9	29	E5245/16NO2
5/16	24	7.938	72	16	8.00	6.30	9	3	6.9	29	E5245/16NO3
5/16	24	7.938	72	16	8.00	6.30	9	3	6.9	29	E5245/16NO6
3/8	24	9.525	80	18	10.00	8.00	11	3	8.5	32	E5243/8NO1
3/8	24	9.525	80	18	10.00	8.00	11	3	8.5	32	E5243/8NO2
3/8	24	9.525	80	18	10.00	8.00	11	3	8.5	32	E5243/8NO3

N01 - N09
219

UNF	TPI	d ₁ nom mm	l ₁ mm	l ₂ mm	d ₂ ∅ mm	∠ a mm	l ₃ mm	z		l ₄ mm	E524
3/8	24	9.525	80	18	10.00	8.00	11	3	8.5	32	E5243/8NO6
7/16	20	11.112	85	19	8.00	6.30	9	3	9.9	-	E5247/16NO1
7/16	20	11.112	85	19	8.00	6.30	9	3	9.9	-	E5247/16NO2
7/16	20	11.112	85	19	8.00	6.30	9	3	9.9	-	E5247/16NO3
7/16	20	11.112	85	19	8.00	6.30	9	3	9.9	-	E5247/16NO6
1/2	20	12.700	89	22	9.00	7.10	10	3	11.5	-	E5241/2NO1
1/2	20	12.700	89	22	9.00	7.10	10	3	11.5	-	E5241/2NO2
1/2	20	12.700	89	22	9.00	7.10	10	3	11.5	-	E5241/2NO3
1/2	20	12.700	89	22	9.00	7.10	10	3	11.5	-	E5241/2NO6
9/16	18	14.288	95	24	11.20	9.00	12	4	12.9	-	E5249/16NO1
9/16	18	14.288	95	24	11.20	9.00	12	4	12.9	-	E5249/16NO2
9/16	18	14.288	95	24	11.20	9.00	12	4	12.9	-	E5249/16NO3
9/16	18	14.288	95	24	11.20	9.00	12	4	12.9	-	E5249/16NO6
5/8	18	15.875	102	24	12.50	10.00	13	4	14.5	-	E5245/8NO1
5/8	18	15.875	102	24	12.50	10.00	13	4	14.5	-	E5245/8NO2
5/8	18	15.875	102	24	12.50	10.00	13	4	14.5	-	E5245/8NO3
5/8	18	15.875	102	24	12.50	10.00	13	4	14.5	-	E5245/8NO6
3/4	16	19.050	112	29	14.00	11.20	14	4	17.5	-	E5243/4NO1
3/4	16	19.050	112	29	14.00	11.20	14	4	17.5	-	E5243/4NO2
3/4	16	19.050	112	29	14.00	11.20	14	4	17.5	-	E5243/4NO3
3/4	16	19.050	112	29	14.00	11.20	14	4	17.5	-	E5243/4NO6
7/8	14	22.225	118	29	16.00	12.50	16	4	20.4	-	E5247/8NO1
7/8	14	22.225	118	29	16.00	12.50	16	4	20.4	-	E5247/8NO2
7/8	14	22.225	118	29	16.00	12.50	16	4	20.4	-	E5247/8NO3
7/8	14	22.225	118	29	16.00	12.50	16	4	20.4	-	E5247/8NO6
1"	12	25.400	130	35	18.00	14.00	18	4	23.25	-	E5241NO1
1"	12	25.400	130	35	18.00	14.00	18	4	23.25	-	E5241NO2
1"	12	25.400	130	35	18.00	14.00	18	4	23.25	-	E5241NO3
1"	12	25.400	130	35	18.00	14.00	18	4	23.25	-	E5241NO6
1.1/8	12	28.575	138	35	20.00	16.00	20	4	26.5	-	E5241.1/8NO1
1.1/8	12	28.575	138	35	20.00	16.00	20	4	26.5	-	E5241.1/8NO2
1.1/8	12	28.575	138	35	20.00	16.00	20	4	26.5	-	E5241.1/8NO3
1.1/4	12	31.750	151	41	22.40	18.00	22	4	29.5	-	E5241.1/4NO1
1.1/4	12	31.750	151	41	22.40	18.00	22	4	29.5	-	E5241.1/4NO2
1.1/4	12	31.750	151	41	22.40	18.00	22	4	29.5	-	E5241.1/4NO3
1.3/8	12	34.925	162	47	25.00	20.00	24	4	32.75	-	E5241.3/8NO1
1.3/8	12	34.925	162	47	25.00	20.00	24	4	32.75	-	E5241.3/8NO2
1.3/8	12	34.925	162	47	25.00	20.00	24	4	32.75	-	E5241.3/8NO3
1.1/2	12	38.100	170	47	28.00	22.40	26	4	36	-	E5241.1/2NO1
1.1/2	12	38.100	170	47	28.00	22.40	26	4	36	-	E5241.1/2NO2
1.1/2	12	38.100	170	47	28.00	22.40	26	4	36	-	E5241.1/2NO3

NO1 - NO9





219

EP30 EP31

- UNF Maschi a macchina imbocco corretto
- UNF Maschinen-Gewindebohrer, geradegenutet mit Schälanschnitt
- UNF Machinetap met schilaansnijding
- UNF Tarauds machine Coupe gun

Fornito in HSS-E fino a nuovo stock
 Lieferung in HSS-E bis neuer Lagerbestand verfügbar ist
 Geleverd in HSS-E tot de nieuwe voorraad beschikbaar is
 Fourni en HSS-E jusqu'à ce que le nouveau stock soit disponible

EP30	▪	1.1	1.2	1.3	1.4	1.5	6.1	6.3	7.1	7.2	7.3	7.4	
	•	1.6	3.1	3.2	3.3	3.4	4.1	4.2	5.1	5.2	6.2	8.1	
EP31	▪	1.1	1.2	1.3	1.4	1.5							
	•	1.6	2.1	2.2	2.3	3.1	3.2	3.3	3.4				

EP30	UNF	DIN 2184-1	2B		2.5XD	HSS-E PM	C 2-3				
EP31	UNF	DIN 2184-1	2B		2.5XD	HSS-E PM	C 2-3			 ST	

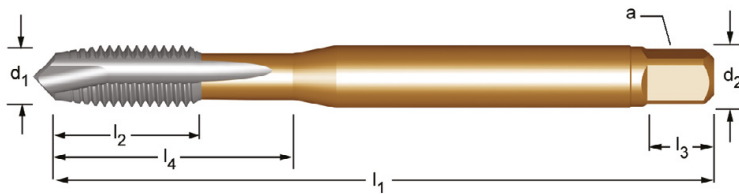

UNF	TPI	d ₁ nom mm	l ₁ mm	l ₂ mm	d ₂ Ø mm	□ a mm	l ₃ mm	z		l ₄ mm	EP30	EP31
8	36	4.166	63	12	4.5	3.4	8	3	3.5	21	EP308-36	EP318-36
10	32	4.826	70	13	6.0	4.9	8	3	4.1	25	EP3010-32	EP3110-32
1/4	28	6.350	80	15	7.0	5.5	8	3	5.5	30	EP301/4	EP311/4
5/16	24	7.938	90	18	8.0	6.2	9	3	6.9	35	EP305/16	EP315/16
3/8	24	9.525	100	20	10.0	8.0	11	3	8.5	39	EP303/8	EP313/8
7/16	20	11.112	100	20	8.0	6.2	9	3	9.9	-	EP307/16	EP317/16
1/2	20	12.700	110	23	9.0	7.0	10	3	11.5	-	EP301/2	EP311/2
5/8	18	15.875	110	25	12.0	9.0	12	3	14.5	-	EP305/8	EP315/8
3/4	16	19.050	125	30	14.0	11.0	14	4	17.5	-	EP303/4	EP313/4
7/8	14	22.225	140	34	18.0	14.5	17	4	20.4	-	EP307/8	EP317/8
1"	12	25.400	160	38	18.0	14.5	17	4	23.25	-	EP301	EP311

E031

- UNF Maschi a macchina imbocco corretto
- UNF Maschinen-Gewindebohrer, geradegenutet mit Schälanschnitt
- UNF Machinetap met schilaansnijding
- UNF Tarauds machine Coupe gun

Fornito in HSS-E fino a nuovo stock
 Lieferung in HSS-E bis neuer Lagerbestand verfügbar ist
 Geleverd in HSS-E tot de nieuwe voorraad beschikbaar is
 Fourni en HSS-E jusqu'à ce que le nouveau stock soit disponible

E031	▪	1.1	1.2	1.3	1.4	1.5				
	•	1.6	2.1	2.2	2.3	3.1	3.2	3.3	3.4	

E031	UNF	ISO 529	2B		2.5XD	HSS-E PM	B 3.5-5			ST	
------	-----	---------	----	--	-------	----------	---------	--	--	----	--

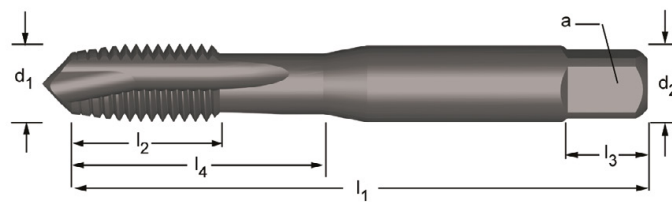





UNF	TPI	d ₁ nom mm	l ₁ mm	l ₂ mm	d ₂ ∅ mm	□ a mm	l ₃ mm	z		l ₄ mm	E031
8	36	4.166	53	9.5	4.5	3.55	6	3	3.50	17	E0318-36
10	32	4.826	58	11	5.0	4.00	7	3	4.10	20	E03110-32
1/4	28	6.350	66	13	6.3	5.00	8	3	5.50	26	E0311/4
5/16	24	7.938	72	16	8.0	6.30	9	3	6.90	29	E0315/16
3/8	24	9.525	80	18	10.0	8.00	11	3	8.50	32	E0313/8
7/16	20	11.112	85	19	8.0	6.30	9	3	9.90	-	E0317/16
1/2	20	12.700	89	22	9.0	7.10	10	3	11.50	-	E0311/2
9/16	18	14.288	95	24	11.2	9.00	12	3	12.90	-	E0319/16
5/8	18	15.875	102	24	12.5	10.00	13	3	14.50	-	E0315/8
3/4	16	19.050	112	29	14.0	11.20	14	4	17.50	-	E0313/4
7/8	14	22.225	118	29	16.0	12.50	16	4	20.40	-	E0317/8
1"	12	25.400	130	35	18.0	14.00	18	4	23.25	-	E0311

EX30 EX31

- UNF Maschi a macchina Scanalature elicoidali 45°
- UNF Maschinen-Gewindebohrer, rechtsgedrallte Nuten 45°
- UNF Machinetap met gespiraliseerde spaangroeven 45°
- UNF Tarauds machine goujures hélicoïdales 45°

Fornito in HSS-E fino a nuovo stock
 Lieferung in HSS-E bis neuer Lagerbestand verfügbar ist
 Geleverd in HSS-E tot de nieuwe voorraad beschikbaar is
 Fourni en HSS-E jusqu'à ce que le nouveau stock soit disponible

EX30	▪	1.1	1.2	1.3	1.4	1.5	7.1	7.2	7.3	7.4
	•	4.1	4.2	5.1	5.2					
EX31	▪	1.1	1.2	1.3	1.4	1.5	2.1	2.2		
	•	2.3								

EX30	UNF	DIN 2184-1	2B		2.5XD	HSS-E PM	C 2-3		$\lambda 45^\circ$			
EX31	UNF	DIN 2184-1	2B		2.5XD	HSS-E PM	C 2-3		$\lambda 45^\circ$		 ST	

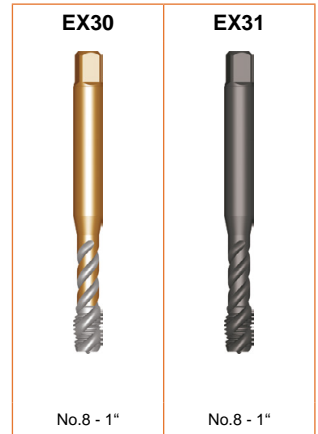
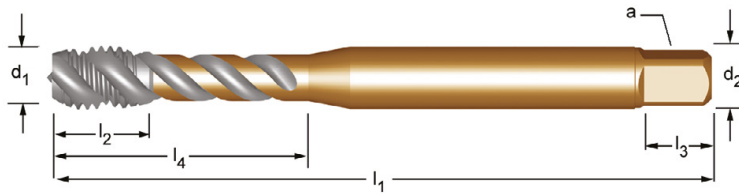

UNF	TPI	d ₁ nom mm	l ₁ mm	l ₂ mm	d ₂ Ø mm	a mm	l ₃ mm	z		l ₄ mm	EX30	EX31
8	36	4.166	63	7	4.5	3.4	8	3	3.5	21	EX308-36	EX318-36
10	32	4.826	70	8	6.0	4.9	8	3	4.1	25	EX3010-32	EX3110-32
1/4	28	6.350	80	10	7.0	5.5	8	3	5.5	30	EX301/4	EX311/4
5/16	24	7.938	90	12	8.0	6.2	9	3	6.9	35	EX305/16	EX315/16
3/8	24	9.525	100	15	10.0	8.0	11	3	8.5	39	EX303/8	EX313/8
7/16	20	11.112	100	15	8.0	6.2	9	3	9.9	-	EX307/16	EX317/16
1/2	20	12.700	110	18	9.0	7.0	10	3	11.5	-	EX301/2	EX311/2
5/8	18	15.875	110	20	12.0	9.0	12	4	14.5	-	EX305/8	EX315/8
3/4	16	19.050	125	25	14.0	11.0	14	4	17.5	-	EX303/4	EX313/4
7/8	14	22.225	140	25	18.0	14.5	17	4	20.4	-	EX307/8	EX317/8
1"	12	25.400	160	30	18.0	14.5	17	4	23.25	-	EX301	EX311

E033

- UNF Maschi a macchina Scanalature elicoidali 45°
- UNF Maschinen-Gewindebohrer, rechtsgedallte Nuten 45°
- UNF Machinetap met gespiraliseerde spaangroeven 45°
- UNF Tarauds machine goujures hélicoïdales 45°

Fornito in HSS-E fino a nuovo stock
 Lieferung in HSS-E bis neuer Lagerbestand verfügbar ist
 Geleverd in HSS-E tot de nieuwe voorraad beschikbaar is
 Fourni en HSS-E jusqu'à ce que le nouveau stock soit disponible

E033	▪	1.1	1.2	1.3	1.4	1.5
	•	1.6	2.1	2.2	2.3	

E033 UNF ISO 529 2B 2.5XD HSS-E PM C 2-3 λ45° ST

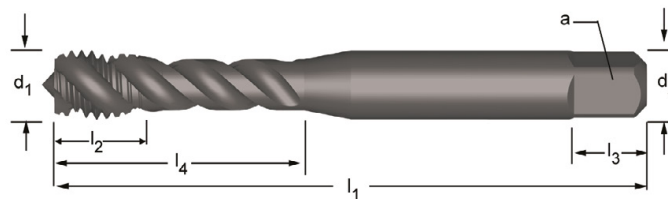

UNF	TPI	d ₁ nom mm	l ₁ mm	l ₂ mm	d ₂ ∅ mm	□ a mm	l ₃ mm	z	↔	l ₄ mm	E033
8	36	4.166	53	7	4.5	3.55	6	3	3.50	17	E0338-36
10	32	4.826	58	8	5.0	4.00	7	3	4.10	20	E03310-32
1/4	28	6.350	66	10	6.3	5.00	8	3	5.50	28	E0331/4
5/16	24	7.938	72	12	8.0	6.30	9	3	6.90	31	E0335/16
3/8	24	9.525	80	15	10.0	8.00	11	3	8.50	34	E0333/8
7/16	20	11.112	85	19	8.0	6.30	9	3	9.90	-	E0337/16
1/2	20	12.700	89	22	9.0	7.10	10	3	11.50	-	E0331/2
9/16	18	14.288	95	24	11.2	9.00	12	3	12.90	-	E0339/16
5/8	18	15.875	102	24	12.5	10.00	13	4	14.50	-	E0335/8
3/4	16	19.050	112	29	14.0	11.20	14	4	17.50	-	E0333/4
7/8	14	22.225	118	29	16.0	12.50	16	4	20.40	-	E0337/8
1"	12	25.400	130	35	18.0	14.00	18	4	23.25	-	E0331

E654

- UNF Punta a maschiare Scanalature elicoidali 30°
- UNF Kombi-Gewindebohrer, rechtsgedrahte Nuten 30°
- UNF Combi boortap met gespiraliseerde spaangroeven 30°
- UNF Foret tarauteur goujures hélicoidales 30°

E654 • 1.1 1.2 1.3 1.4 3.2 6.2 6.3 7.1 7.2 8.1

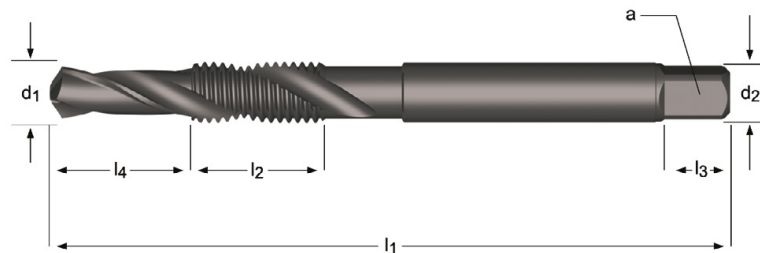

E654



No.8 - 5/8

UNF	TPI	d ₁ nom mm	l ₁ mm	l ₂ mm	l ₄ mm	d ₂ ∅ mm	∠ a mm	z	E654
8	36	3.50	64	13	8	4.5	3.55	2	E6548-36
10	32	4.10	72	16	10	5.0	4.00	2	E65410-32
12	28	4.70	77	17	11	5.6	4.50	2	E65412-28
1/4	28	5.50	83	19	13	6.3	5.00	2	E6541/4
5/16	24	6.90	94	22	16	8.0	6.30	2	E6545/16
3/8	24	8.50	104	24	19	10.0	8.00	2	E6543/8
7/16	20	9.90	107	25	22	8.0	6.30	2	E6547/16
1/2	20	11.50	114	29	25	9.0	7.10	2	E6541/2
5/8	18	14.50	134	32	32	12.5	10.00	2	E6545/8

- E286**
- UNF Maschi a rullare, Canalini di lubrificazione
 - UNF Maschinen-Gewindeformer, Ölnuten / Schmiernuten
 - UNF Machineroltap met smeergroeven
 - UNF Tarauts machine à refouler, rainures de lubrification

E286	▪	1.1	1.2	1.3	1.4	2.1	2.2	4.1	5.1	7.1	7.2	7.3
	•	1.5	2.3	5.2	6.1	6.3	7.4					

E286 UNF DIN 2184-1 2BX 3.5XD HSS-E C 2-3.5

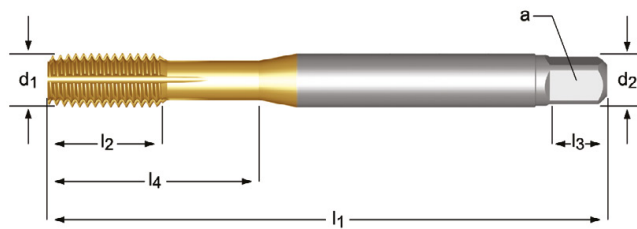

UNF	TPI	d ₁ nom mm	l ₁ mm	l ₂ mm	d ₂ ∅ mm	a mm	l ₃ mm	z		l ₄ mm	E286
4	48	2.845	56	9	3.5	2.7	6	4	2.6	18	E2864-48
6	40	3.505	56	11	4.0	3.0	6	4	3.2	20	E2866-40
8	36	4.166	63	12	4.5	3.4	6	5	3.9	21	E2868-36
10	32	4.826	70	13	6.0	4.9	8	5	4.5	25	E28610-32
1/4	28	6.350	80	15	7.0	5.5	8	5	6.0	30	E2861/4
5/16	24	7.938	90	18	8.0	6.2	9	5	7.5	35	E2865/16
3/8	24	9.525	100	20	10.0	8.0	11	5	9.1	39	E2863/8
7/16	20	11.112	100	20	8.0	6.2	9	5	10.6	-	E2867/16
1/2	20	12.700	100	21	9.0	7.0	10	5	12.1	-	E2861/2

E570

- UN Maschi a macchina Scanalature diritte
- UN Maschinen-Gewindebohrer, geradegenutet
- UN Hand-/machinetap met rechte spaangroeven
- UN Tarauts machine Goujures droite

E570 • 1.1 1.2 1.3 1.4 1.5 3.1 3.2 3.3 3.4 6.1 6.2 6.3 6.4 7.2 7.3 7.4 8.2 8.3

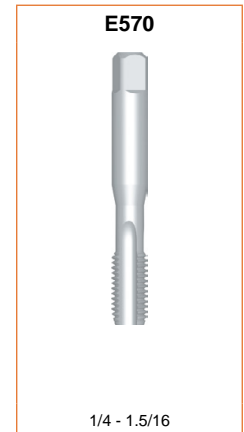
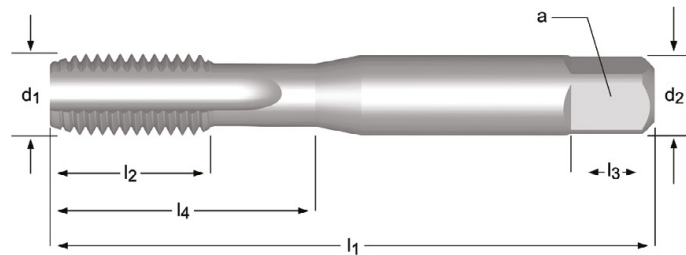

UN	TPI	d ₁ nom mm	l ₁ mm	l ₂ mm	d ₂ ∅ mm	∅ a mm	z		l ₄ mm	E570
1/4	32	6.350	66	13	6.3	5.00	3	5.6	26	E5701/4X32NO3
1/4	36	6.350	66	13	6.3	5.00	3	5.7	26	E5701/4X36NO3
1/4	40	6.350	66	13	6.3	5.00	3	5.7	26	E5701/4X40NO3
5/16	32	7.938	72	16	8.0	6.30	3	7.2	29	E5705/16X32NO3
3/8	32	9.525	80	18	10.0	8.00	3	8.8	32	E5703/8X32NO3
7/16	24	11.112	85	19	8.0	6.30	3	10	-	E5707/16X24NO3
7/16	28	11.112	85	19	8.0	6.30	3	10.2	-	E5707/16X28NO3
1/2	28	12.700	89	22	9.0	7.10	3	11.8	-	E5701/2X28NO3
9/16	24	14.288	95	24	11.2	9.00	4	13.25	-	E5709/16X24NO3
5/8	24	15.875	102	24	12.5	10.00	4	14.8	-	E5705/8X24NO3
3/4	20	19.050	112	29	14.0	11.20	4	17.8	-	E5703/4X20NO3
7/8	20	22.225	118	30	16.0	12.50	4	21	-	E5707/8X20NO3
1"	14	25.400	130	36	18.0	14.00	4	23.5	-	E5701X14NO3
1.1/16	12	26.988	127	37	20.0	16.00	4	24.75	-	E5701.1/16X12NO3
1.1/8	8	28.575	138	35	20.0	16.00	4	25.5	-	E5701.1/8X8NO3
1.3/16	12	30.163	137	37	22.4	18.00	4	28	-	E5701.3/16X12NO3
1.1/4	8	31.750	151	41	22.4	18.00	4	28.5	-	E5701.1/4X8NO3
1.5/16	12	33.338	137	37	22.4	18.00	4	31.25	-	E5701.5/16X12NO3

NO1 - NO9

219

- E115**
- BSW Maschi a mano Scanalature diritte
 - BSW Handgewindebohrer, geradegenutet
 - BSW Handtap met rechte spaangroeven
 - BSW Tarauds à main Goujures droites

E115 • 1.1 1.2 1.3 1.4 1.5 3.1 3.2 3.3 3.4 6.1 6.2 6.3 6.4 7.2 7.3 7.4 8.2 8.3

E115 BSW DIN 351 Medium 1.5XD HSS C 2-3

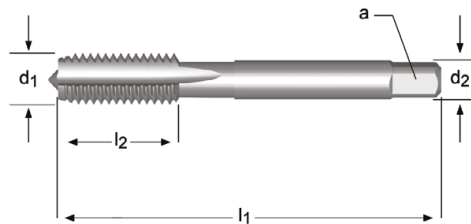

BSW	TPI	d ₁ nom mm	l ₁ mm	l ₂ mm	d ₂ ∅ mm	∠ a mm	z		E115
1/8	40	3.175	40	10	3.5	2.7	3	2.55	E1151/8NO3
1/8	40	3.175	40	10	3.5	2.7	3	2.55	E1151/8NO8
5/32	32	3.969	45	12	4.5	3.4	3	3.2	E1155/32NO3
5/32	32	3.969	45	12	4.5	3.4	3	3.2	E1155/32NO8
3/16	24	4.763	50	16	5.5	4.3	3	3.7	E1153/16NO3
3/16	24	4.763	50	16	5.5	4.3	3	3.7	E1153/16NO8
1/4	20	6.350	56	17	6.0	4.9	3	5.1	E1151/4NO3
1/4	20	6.350	56	17	6.0	4.9	3	5.1	E1151/4NO8
5/16	18	7.938	63	25	6.0	4.9	3	6.5	E1155/16NO3
5/16	18	7.938	63	25	6.0	4.9	3	6.5	E1155/16NO8
3/8	16	9.525	70	22	7.0	5.5	3	7.9	E1153/8NO3
3/8	16	9.525	70	22	7.0	5.5	3	7.9	E1153/8NO8
7/16	14	11.113	75	30	8.0	6.2	3	9.2	E1157/16NO3
7/16	14	11.113	75	30	8.0	6.2	3	9.2	E1157/16NO8
1/2	12	12.700	80	30	9.0	7.0	3	10.5	E1151/2NO3
1/2	12	12.700	80	30	9.0	7.0	3	10.5	E1151/2NO8
9/16	12	14.288	80	30	11.0	9.0	4	12	E1159/16NO3
9/16	12	14.288	80	30	11.0	9.0	4	12	E1159/16NO8
5/8	11	15.875	90	36	12.0	9.0	4	13.5	E1155/8NO3
5/8	11	15.875	90	36	12.0	9.0	4	13.5	E1155/8NO8
3/4	10	19.050	105	40	14.0	11.0	4	16.5	E1153/4NO3
3/4	10	19.050	105	40	14.0	11.0	4	16.5	E1153/4NO8
7/8	9	22.225	110	45	18.0	14.5	4	19.25	E1157/8NO3
7/8	9	22.225	110	45	18.0	14.5	4	19.25	E1157/8NO8
1"	8	25.400	110	50	20.0	16.0	4	22	E1151NO3
1"	8	25.400	110	50	20.0	16.0	4	22	E1151NO8

NO1 - NO9
219

- E531**
- BSW Maschi a macchina Scanalature diritte
 - BSW Maschinen-Gewindebohrer, geradegenutet
 - BSW Hand-/machinetap met rechte spaangroeven
 - BSW Tarauds machine Goujures droites

E531 • 1.1 1.2 1.3 1.4 1.5 3.1 3.2 3.3 3.4 6.1 6.2 6.3 6.4 7.2 7.3 7.4 8.2 8.3

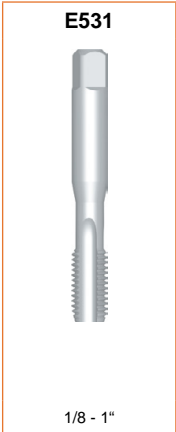
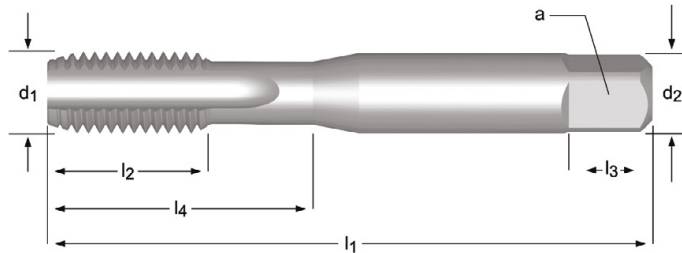
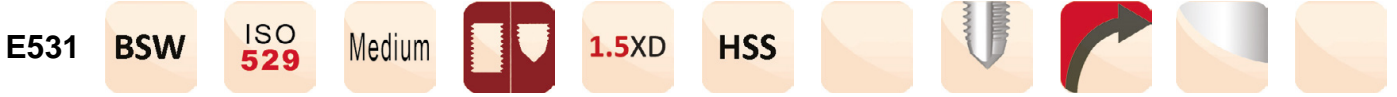

BSW	TPI	d ₁ nom mm	l ₁ mm	l ₂ mm	d ₂ Ø mm	□ a mm	z		l ₄ mm	E531
1/8	40	3.175	48	12.5	3.15	2.50	3	2.55	12.5	E5311/8NO1
1/8	40	3.175	48	12.5	3.15	2.50	3	2.55	12.5	E5311/8NO2
1/8	40	3.175	48	12.5	3.15	2.50	3	2.55	12.5	E5311/8NO3
1/8	40	3.175	48	12.5	3.15	2.50	3	2.55	12.5	E5311/8NO6
5/32	32	3.969	53	14	4.00	3.15	3	3.2	14	E5315/32NO1
5/32	32	3.969	53	14	4.00	3.15	3	3.2	14	E5315/32NO2
5/32	32	3.969	53	14	4.00	3.15	3	3.2	14	E5315/32NO3
5/32	32	3.969	53	14	4.00	3.15	3	3.2	14	E5315/32NO6
3/16	24	4.763	58	11	5.00	4.00	3	3.7	20	E5313/16NO1
3/16	24	4.763	58	11	5.00	4.00	3	3.7	20	E5313/16NO2
3/16	24	4.763	58	11	5.00	4.00	3	3.7	20	E5313/16NO3
3/16	24	4.763	58	11	5.00	4.00	3	3.7	20	E5313/16NO6
1/4	20	6.350	66	13	6.30	5.00	3	5.1	26	E5311/4NO1
1/4	20	6.350	66	13	6.30	5.00	3	5.1	26	E5311/4NO2
1/4	20	6.350	66	13	6.30	5.00	3	5.1	26	E5311/4NO3
1/4	20	6.350	66	13	6.30	5.00	3	5.1	26	E5311/4NO6
5/16	18	7.938	72	16	8.00	6.30	3	6.5	29	E5315/16NO1
5/16	18	7.938	72	16	8.00	6.30	3	6.5	29	E5315/16NO2
5/16	18	7.938	72	16	8.00	6.30	3	6.5	29	E5315/16NO3
5/16	18	7.938	72	16	8.00	6.30	3	6.5	29	E5315/16NO6
3/8	16	9.525	80	18	10.00	8.00	3	7.9	32	E5313/8NO1
3/8	16	9.525	80	18	10.00	8.00	3	7.9	32	E5313/8NO2
3/8	16	9.525	80	18	10.00	8.00	3	7.9	32	E5313/8NO3
3/8	16	9.525	80	18	10.00	8.00	3	7.9	32	E5313/8NO6
7/16	14	11.112	85	19	8.00	6.30	3	9.2	-	E5317/16NO1
7/16	14	11.112	85	19	8.00	6.30	3	9.2	-	E5317/16NO2
7/16	14	11.112	85	19	8.00	6.30	3	9.2	-	E5317/16NO3
7/16	14	11.112	85	19	8.00	6.30	3	9.2	-	E5317/16NO6
1/2	12	12.700	89	22	9.00	7.10	3	10.5	-	E5311/2NO1
1/2	12	12.700	89	22	9.00	7.10	3	10.5	-	E5311/2NO2
1/2	12	12.700	89	22	9.00	7.10	3	10.5	-	E5311/2NO3
1/2	12	12.700	89	22	9.00	7.10	3	10.5	-	E5311/2NO6
5/8	11	15.875	102	24	12.50	10.00	4	13.5	-	E5315/8NO1
5/8	11	15.875	102	24	12.50	10.00	4	13.5	-	E5315/8NO2
5/8	11	15.875	102	24	12.50	10.00	4	13.5	-	E5315/8NO3
5/8	11	15.875	102	24	12.50	10.00	4	13.5	-	E5315/8NO6
3/4	10	19.050	112	29	14.00	11.20	4	16.5	-	E5313/4NO1
3/4	10	19.050	112	29	14.00	11.20	4	16.5	-	E5313/4NO2
3/4	10	19.050	112	29	14.00	11.20	4	16.5	-	E5313/4NO3
3/4	10	19.050	112	29	14.00	11.20	4	16.5	-	E5313/4NO6

NO1 - NO9
219

BSW	TPI	d ₁ nom mm	l ₁ mm	l ₂ mm	d ₂ ∅ mm	∇ a mm	z		l ₄ mm	E531
1"	8	25.400	130	35	18.00	14.00	4	22	-	E5311NO1
1"	8	25.400	130	35	18.00	14.00	4	22	-	E5311NO2
1"	8	25.400	130	35	18.00	14.00	4	22	-	E5311NO3
1"	8	25.400	130	35	18.00	14.00	4	22	-	E5311NO6



- E534**
- BSW Maschi a macchina imbocco corretto
 - BSW Maschinen-Gewindebohrer, geradegenutet mit Schälanschnitt
 - BSW Machinetap met schilaansnijding
 - BSW Tarauds machine Coupe gun

E534	▪	1.1	1.2	1.3	1.4	2.1	2.2	2.3					
	•	1.5	1.6	4.3	5.1	5.2	6.1	6.3	7.1	7.2	7.3	7.4	8.1

E534 **BSW** **ISO 529** **Medium**  **2.5XD** **HSS** **B 3.5-5**   **ST** 

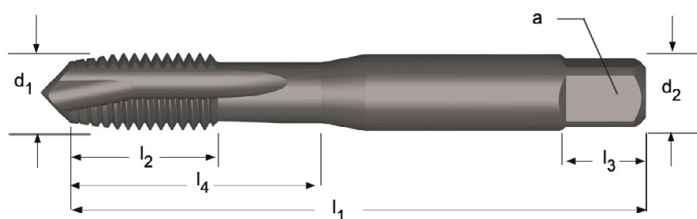

E534



1/8 - 3/4

BSW	TPI	d ₁ nom mm	l ₁ mm	l ₂ mm	d ₂ ∅ mm	a mm	z		l ₄ mm	E534
1/8	40	3.175	48	12.5	3.15	2.50	3	2.55	12.5	E5341/8
5/32	32	3.969	53	14	4.00	3.15	3	3.2	14	E5345/32
3/16	24	4.763	58	11	5.00	4.00	3	3.7	20	E5343/16
1/4	20	6.350	66	13	6.30	5.00	3	5.1	26	E5341/4
5/16	18	7.938	72	16	8.00	6.30	3	6.5	29	E5345/16
3/8	16	9.525	80	18	10.00	8.00	3	7.9	32	E5343/8
7/16	14	11.112	85	19	8.00	6.30	3	9.2	-	E5347/16
1/2	12	12.700	89	22	9.00	7.10	3	10.5	-	E5341/2
5/8	11	15.875	102	24	12.50	10.00	3	13.5	-	E5345/8
3/4	10	19.050	112	29	14.00	11.20	4	16.5	-	E5343/4

- # E533
- BSW Maschi a macchina Scanalature elicoidali 40°
 - BSW Maschinen-Gewindebohrer, rechtsgedrallte Nuten 40°
 - BSW Machinetap met gespiraliseerde spaangroeven 40°
 - BSW Tarauds machine goujures hélicoidales 40°

E533	▪	1.2	1.3	1.4	2.1	2.2	2.3
	•	1.5	5.2	7.1	7.2	7.3	7.4

E533 **BSW** **ISO 529** Medium **HSS** **C 2-3** $\lambda 40^\circ$

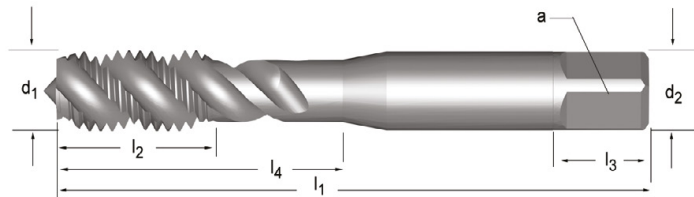

BSW	TPI	d ₁ nom mm	l ₁ mm	l ₂ mm	d ₂ Ø mm	□ a mm	z		l ₄ mm	E533
1/8	40	3.175	48	12.5	3.15	2.50	3	2.55	12.5	E5331/8 ³⁾
1/8	40	3.175	48	12.5	3.15	2.50	3	2.55	12.5	E5331/8BLUE
3/16	24	4.763	58	11	5.00	4.00	3	3.7	20	E5333/16 ³⁾
3/16	24	4.763	58	11	5.00	4.00	3	3.7	20	E5333/16BLUE
1/4	20	6.350	66	13	6.30	5.00	3	5.1	26	E5331/4 ³⁾
1/4	20	6.350	66	13	6.30	5.00	3	5.1	26	E5331/4BLUE
5/16	18	7.938	72	16	8.00	6.30	3	6.5	31	E5335/16 ³⁾
5/16	18	7.938	72	16	8.00	6.30	3	6.5	31	E5335/16BLUE
3/8	16	9.525	80	18	10.00	8.00	3	7.9	34	E5333/8 ³⁾
3/8	16	9.525	80	18	10.00	8.00	3	7.9	34	E5333/8BLUE
1/2	12	12.700	89	22	9.00	7.10	3	10.5	-	E5331/2 ³⁾
1/2	12	12.700	89	22	9.00	7.10	3	10.5	-	E5331/2BLUE
5/8	11	15.875	102	24	12.50	10.00	3	13.5	-	E5335/8 ³⁾
5/8	11	15.875	102	24	12.50	10.00	3	13.5	-	E5335/8BLUE
3/4	10	19.050	112	29	14.00	11.20	3	16.5	-	E5333/4 ³⁾
3/4	10	19.050	112	29	14.00	11.20	3	16.5	-	E5333/4BLUE





³⁾ Senza / Blank / Blank / Brillant

- E536**
- BSF Maschi a macchina Scanalature diritte
 - BSF Maschinen-Gewindebohrer, geradegenutet
 - BSF Hand-/machinetap met rechte spaangroeven
 - BSF Tarauds machine Goujures droites

E536 ■ **6.1**

• **1.1 1.2 1.3 1.4 1.5 1.6 2.1 2.2 2.3 3.1 3.2 3.3 3.4 6.2 6.3 6.4 7.2 7.3 7.4 8.2**

8.3

E536 **BSF** **ISO 529** **Medium**  **1.5XD** **HSS**     

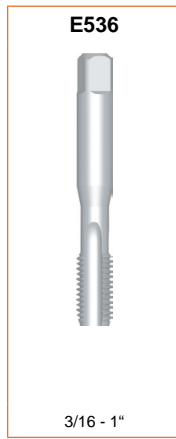
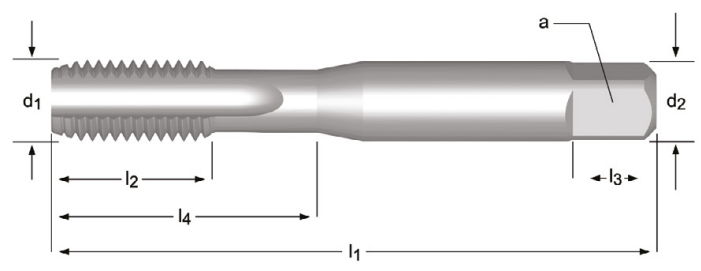

BSF	TPI	d ₁ nom mm	l ₁ mm	l ₂ mm	d ₂ Ø mm	□ a mm	z		l ₄ mm	E536
3/16	32	4.76	58	12	5.0	4.0	3	4	20	E5363/16NO1
3/16	32	4.76	58	12	5.0	4.0	3	4	20	E5363/16NO2
3/16	32	4.76	58	12	5.0	4.0	3	4	20	E5363/16NO3
3/16	32	4.76	58	12	5.0	4.0	3	4	20	E5363/16NO6
1/4	26	6.35	66	14	6.3	5.0	3	5.3	26	E5361/4NO1
1/4	26	6.35	66	14	6.3	5.0	3	5.3	26	E5361/4NO2
1/4	26	6.35	66	14	6.3	5.0	3	5.3	26	E5361/4NO3
1/4	26	6.35	66	14	6.3	5.0	3	5.3	26	E5361/4NO6
5/16	22	7.94	72	18	8.0	6.3	3	6.8	29	E5365/16NO1
5/16	22	7.94	72	18	8.0	6.3	3	6.8	29	E5365/16NO2
5/16	22	7.94	72	18	8.0	6.3	3	6.8	29	E5365/16NO3
5/16	22	7.94	72	18	8.0	6.3	3	6.8	29	E5365/16NO6
3/8	20	9.53	80	20	10.0	8.0	3	8.3	32	E5363/8NO1
3/8	20	9.53	80	20	10.0	8.0	3	8.3	32	E5363/8NO2
3/8	20	9.53	80	20	10.0	8.0	3	8.3	32	E5363/8NO3
3/8	20	9.53	80	20	10.0	8.0	3	8.3	32	E5363/8NO6
7/16	18	11.11	85	20	8.0	6.3	3	9.7	-	E5367/16NO1
7/16	18	11.11	85	20	8.0	6.3	3	9.7	-	E5367/16NO2
7/16	18	11.11	85	20	8.0	6.3	3	9.7	-	E5367/16NO3
1/2	16	12.70	89	23	9.0	7.1	3	11	-	E5361/2NO1
1/2	16	12.70	89	23	9.0	7.1	3	11	-	E5361/2NO2
1/2	16	12.70	89	23	9.0	7.1	3	11	-	E5361/2NO3
1/2	16	12.70	89	23	9.0	7.1	3	11	-	E5361/2NO6
9/16	16	14.28	95	25	11.2	9.0	4	12.7	-	E5369/16NO1
9/16	16	14.28	95	25	11.2	9.0	4	12.7	-	E5369/16NO2
9/16	16	14.28	95	25	11.2	9.0	4	12.7	-	E5369/16NO3
5/8	14	15.88	102	25	12.5	10.0	4	14	-	E5365/8NO1
5/8	14	15.88	102	25	12.5	10.0	4	14	-	E5365/8NO2
5/8	14	15.88	102	25	12.5	10.0	4	14	-	E5365/8NO3
3/4	12	19.05	112	30	14.0	11.2	4	17	-	E5363/4NO1
3/4	12	19.05	112	30	14.0	11.2	4	17	-	E5363/4NO2
3/4	12	19.05	112	30	14.0	11.2	4	17	-	E5363/4NO3
7/8	11	22.23	118	30	16.0	12.5	4	19.75	-	E5367/8NO1
7/8	11	22.23	118	30	16.0	12.5	4	19.75	-	E5367/8NO2
7/8	11	22.23	118	30	16.0	12.5	4	19.75	-	E5367/8NO3
7/8	11	22.23	118	30	16.0	12.5	4	19.75	-	E5367/8NO6
1"	10	25.40	130	36	18.0	14.0	4	22.75	-	E5361NO1
1"	10	25.40	130	36	18.0	14.0	4	22.75	-	E5361NO2
1"	10	25.40	130	36	18.0	14.0	4	22.75	-	E5361NO3

NO1 - NO9
219

- E539**
- BSF Maschi a macchina imbocco corretto
 - BSF Maschinen-Gewindebohrer, geradegenutet mit Schälanschnitt
 - BSF Machinetap met schilaansnijding
 - BSF Tarauds machine Coupe gun

E539	▪	1.1	1.2	1.3	1.4	2.1	2.2	2.3					
	•	1.5	1.6	4.3	5.1	5.2	6.1	6.3	7.1	7.2	7.3	7.4	8.1

E539 **BSF** **ISO 529** Medium **2.5XD** **HSS** **B 3.5-5**

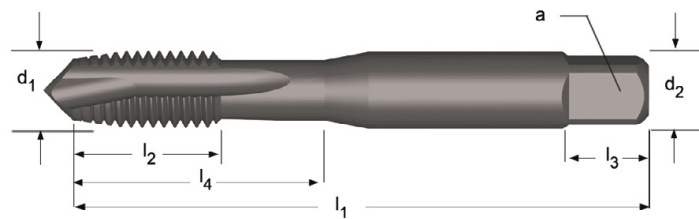

BSF	TPI	d ₁ nom mm	l ₁ mm	l ₂ mm	d ₂ Ø mm	∠ a mm	z		l ₄ mm	E539
1/4	26	6.35	66	14	6.3	5.0	3	5.3	26	E5391/4
5/16	22	7.94	72	18	8.0	6.3	3	6.8	29	E5395/16
3/8	20	9.53	80	20	10.0	8.0	3	8.3	32	E5393/8
1/2	16	12.70	89	23	9.0	7.1	3	11	-	E5391/2

E538

- BSF Maschi a macchina Scanalature elicoidali 40°
- BSF Maschinen-Gewindebohrer, rechtsgedrahte Nuten 40°
- BSF Machinetap met gespiraliseerde spaangroeven 40°
- BSF Tarauds machine goujures hélicoidales 40°

E538	▪	1.2	1.3	1.4	2.1	2.2	2.3
	•	1.5	5.2	7.1	7.2	7.3	7.4

E538 **BSF** **ISO 529** Medium  **2XD** **HSS** **C 2-3**  **λ 40°**  **ST**

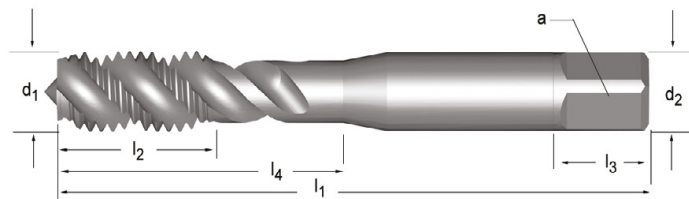

E538



1/4 - 1/2

BSF	TPI	d ₁ nom mm	l ₁ mm	l ₂ mm	d ₂ Ø mm	□ a mm	z		l ₄ mm	E538
1/4	26	6.350	66	13	6.3	5.00	3	5.3	26	E5381/4 ³⁾
1/4	26	6.350	66	13	6.3	5.00	3	5.3	26	E5381/4BLUE
5/16	22	7.938	72	16	8.0	6.30	3	6.8	31	E5385/16 ³⁾
5/16	22	7.938	72	16	8.0	6.30	3	6.8	31	E5385/16BLUE
3/8	20	9.525	80	18	10.0	8.00	3	8.3	34	E5383/8 ³⁾
3/8	20	9.525	80	18	10.0	8.00	3	8.3	34	E5383/8BLUE
1/2	16	12.700	89	22	9.0	7.10	3	11	-	E5381/2 ³⁾
1/2	16	12.700	89	22	9.0	7.10	3	11	-	E5381/2BLUE

E542

- BA Maschi a macchina Scanalature diritte
- BA Maschinen-Gewindebohrer, geradegenutet
- BA Machinetap met rechte spaangroeven
- BA Tarauds machine Goujures droites

E542 • 1.1 1.2 1.3 1.4 1.5 3.1 3.2 3.3 3.4 6.1 6.2 6.3 6.4 7.2 7.3 7.4 8.2 8.3

E542

BA

ISO
529

Normal



1.5XD

HSS

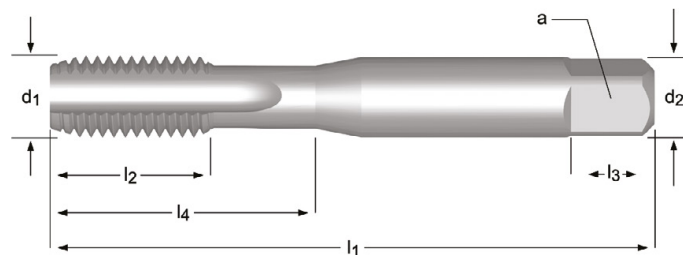

E542



No.10 - No.0

BA	P mm	d ₁ nom mm	l ₁ mm	l ₂ mm	d ₂ Ø mm	□ a mm	l ₃ mm	z		l ₄ mm	E542
BA10	0.35	1.70	41	7.0	2.50	2.0	4	2	1.3	7	E542BA10NO1
BA10	0.35	1.70	41	7.0	2.50	2.0	4	2	1.3	7	E542BA10NO2
BA10	0.35	1.70	41	7.0	2.50	2.0	4	2	1.3	7	E542BA10NO3
BA10	0.35	1.70	41	7.0	2.50	2.0	4	2	1.3	7	E542BA10NO6
BA 8	0.43	2.20	44.5	9.5	2.80	2.2	5	3	1.8	9.5	E542BA8NO1
BA 8	0.43	2.20	44.5	9.5	2.80	2.2	5	3	1.8	9.5	E542BA8NO2
BA 8	0.43	2.20	44.5	9.5	2.80	2.2	5	3	1.8	9.5	E542BA8NO3
BA 8	0.43	2.20	44.5	9.5	2.80	2.2	5	3	1.8	9.5	E542BA8NO6
BA 6	0.53	2.80	44.5	9.5	2.80	2.2	5	3	2.3	9.5	E542BA6NO1
BA 6	0.53	2.80	44.5	9.5	2.80	2.2	5	3	2.3	9.5	E542BA6NO2
BA 6	0.53	2.80	44.5	9.5	2.80	2.2	5	3	2.3	9.5	E542BA6NO3
BA 6	0.53	2.80	44.5	9.5	2.80	2.2	5	3	2.3	9.5	E542BA6NO6
BA 5	0.59	3.20	48	14.5	3.15	2.5	5	3	2.65	14.5	E542BA5NO1
BA 5	0.59	3.20	48	14.5	3.15	2.5	5	3	2.65	14.5	E542BA5NO2
BA 5	0.59	3.20	48	14.5	3.15	2.5	5	3	2.65	14.5	E542BA5NO3
BA 5	0.59	3.20	48	14.5	3.15	2.5	5	3	2.65	14.5	E542BA5NO6
BA 4	0.66	3.60	50	16.5	3.55	2.8	5	3	3	16.5	E542BA4NO1
BA 4	0.66	3.60	50	16.5	3.55	2.8	5	3	3	16.5	E542BA4NO2
BA 4	0.66	3.60	50	16.5	3.55	2.8	5	3	3	16.5	E542BA4NO3
BA 4	0.66	3.60	50	16.5	3.55	2.8	5	3	3	16.5	E542BA4NO6
BA 3	0.73	4.10	53	10.0	4.50	3.5	6	3	3.4	17	E542BA3NO1
BA 3	0.73	4.10	53	10.0	4.50	3.5	6	3	3.4	17	E542BA3NO2
BA 3	0.73	4.10	53	10.0	4.50	3.5	6	3	3.4	17	E542BA3NO3
BA 3	0.73	4.10	53	10.0	4.50	3.5	6	3	3.4	17	E542BA3NO6
BA 2	0.81	4.70	58	12.0	5.00	4.0	7	3	4	20	E542BA2NO1
BA 2	0.81	4.70	58	12.0	5.00	4.0	7	3	4	20	E542BA2NO2
BA 2	0.81	4.70	58	12.0	5.00	4.0	7	3	4	20	E542BA2NO3
BA 2	0.81	4.70	58	12.0	5.00	4.0	7	3	4	20	E542BA2NO6
BA 0	1.00	6.00	66	14.0	6.30	5.0	8	3	5.1	26	E542BA0NO1
BA 0	1.00	6.00	66	14.0	6.30	5.0	8	3	5.1	26	E542BA0NO2
BA 0	1.00	6.00	66	14.0	6.30	5.0	8	3	5.1	26	E542BA0NO3
BA 0	1.00	6.00	66	14.0	6.30	5.0	8	3	5.1	26	E542BA0NO6

NO1 - NO9



219

E545

- BA Maschi a macchina imbocco corretto
- BA Maschinen-Gewindebohrer, geradegenutet mit Schälanschnitt
- BA Machinetap met schilaansnijding
- BA Tarauds machine Coupe gun

E545	▪	1.1	1.2	1.3	1.4											
	•	1.5	1.6	2.1	2.2	2.3	4.3	5.1	5.2	6.1	6.3	7.1	7.2	7.3	7.4	8.1

E545 **BA** **ISO 529** Normal  **2.5XD** **HSS** **B** 3.5-5    **ST** 

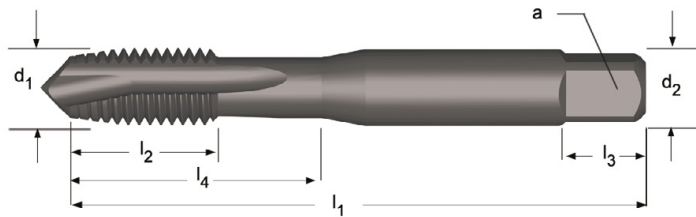

BA	P mm	d ₁ nom mm	l ₁ mm	l ₂ mm	d ₂ Ø mm	∠ a mm	l ₃ mm	z		l ₄ mm	E545
BA10	0.35	1.70	41	7.0	2.50	2.0	4	2	1.3	7	E545BA10
BA 8	0.43	2.20	44.5	9.5	2.80	2.2	5	3	1.8	9.5	E545BA8
BA 6	0.53	2.80	44.5	9.5	2.80	2.2	5	3	2.3	9.5	E545BA6
BA 4	0.66	3.60	50	16.5	3.55	2.8	5	3	3	16.5	E545BA4
BA 2	0.81	4.70	58	12.0	5.00	4.0	7	3	4	20	E545BA2

E544

- BA Maschi a macchina Scanalature elicoidali 40°
- BA Maschinen-Gewindebohrer, rechtsgedrallte Nuten 40°
- BA Machinetap met gespiraliseerde spaangroeven 40°
- BA Tarauds machine goujures hélicoidales 40°

E544	▪	1.2	1.3	1.4	2.1	2.2	2.3
	•	1.5	5.2	7.1	7.2	7.3	7.4

E544 **BA** **ISO 529** Normal **2XD** **HSS** **C 2-3** $\lambda 40^\circ$ **ST**

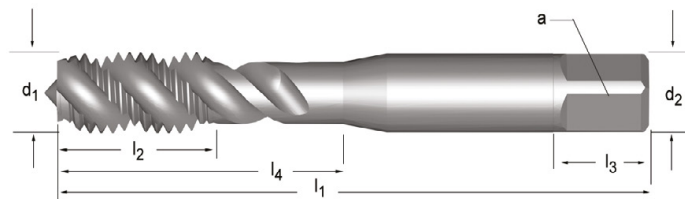

BA	P mm	d ₁ nom mm	l ₁ mm	l ₂ mm	d ₂ Ø mm	∠ a mm	l ₃ mm	z		l ₄ mm	E544
BA 8	0.43	2.20	44.5	9.5	2.80	2.2	5	2	1.8	9.5	E544BA8 ³⁾
BA 8	0.43	2.20	44.5	9.5	2.80	2.2	5	2	1.8	9.5	E544BA8BLUE
BA 6	0.53	2.80	44.5	9.5	2.80	2.2	5	2	2.3	9.5	E544BA6 ³⁾
BA 6	0.53	2.80	44.5	9.5	2.80	2.2	5	2	2.3	9.5	E544BA6BLUE
BA 4	0.66	3.60	50	16.5	3.55	2.8	5	3	3	16.5	E544BA4 ³⁾
BA 4	0.66	3.60	50	16.5	3.55	2.8	5	3	3	16.5	E544BA4BLUE
BA 2	0.81	4.70	58	12.0	5.00	4.0	7	3	4	20	E544BA2 ³⁾
BA 2	0.81	4.70	58	12.0	5.00	4.0	7	3	4	20	E544BA2BLUE

³⁾ Senza / Blank / Blank / Brillant

- E119**
- G(BSP) Maschi a mano Scanalature diritte
 - G(BSP) Handgewindebohrer, geradegenutet
 - G(BSP) Handtap met rechte spaangroeven
 - G(BSP) Tarauds à main Goujures droites

E119 • 1.1 1.2 1.3 1.4 1.5 3.1 3.2 3.3 3.4 6.1 6.2 6.3 6.4 7.2 7.3 7.4 8.2 8.3

E119 **G** **DIN 5157** Normal  **1.5XD** **HSS** **C 2-3**    

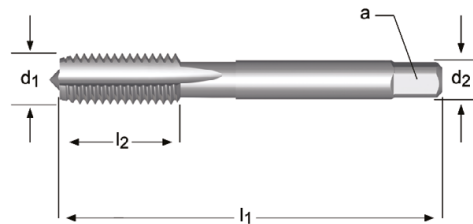

G(BSP)	TPI	d ₁ nom mm	l ₁ mm	l ₂ mm	d ₂ Ø mm	∇ a mm	z		E119
1/8	28	9.73	63	15	7.0	5.5	3	8.8	E1191/8NO3
1/8	28	9.73	63	15	7.0	5.5	3	8.8	E1191/8NO9
1/4	19	13.16	70	16	11.0	9.0	4	11.8	E1191/4NO3
1/4	19	13.16	70	16	11.0	9.0	4	11.8	E1191/4NO9
3/8	19	16.66	70	16	12.0	9.0	4	15.25	E1193/8NO3
3/8	19	16.66	70	16	12.0	9.0	4	15.25	E1193/8NO9
1/2	14	20.96	80	18	16.0	12.0	4	19	E1191/2NO3
1/2	14	20.96	80	18	16.0	12.0	4	19	E1191/2NO9
5/8	14	22.91	80	22	18.0	14.5	4	21	E1195/8NO3
5/8	14	22.91	80	22	18.0	14.5	4	21	E1195/8NO9
3/4	14	26.44	90	22	20.0	16.0	4	24.5	E1193/4NO3
3/4	14	26.44	90	22	20.0	16.0	4	24.5	E1193/4NO9
7/8	14	30.20	90	22	22.0	18.0	6	28.25	E1197/8NO3
7/8	14	30.20	90	22	22.0	18.0	6	28.25	E1197/8NO9
1"	11	33.25	100	25	25.0	20.0	6	30.75	E1191NO3
1"	11	33.25	100	25	25.0	20.0	6	30.75	E1191NO9
1.1/8	11	37.90	125	40	28.0	22.0	6	35	E1191.1/8NO3
1.1/8	11	37.90	125	40	28.0	22.0	6	35	E1191.1/8NO9
1.1/4	11	41.91	125	40	32.0	24.0	6	39.5	E1191.1/4NO3
1.1/4	11	41.91	125	40	32.0	24.0	6	39.5	E1191.1/4NO9
1.1/2	11	47.80	140	40	36.0	29.0	6	45	E1191.1/2NO3
1.1/2	11	47.80	140	40	36.0	29.0	6	45	E1191.1/2NO9
1.3/4	11	53.75	140	40	40.0	32.0	6	51	E1191.3/4NO3
1.3/4	11	53.75	140	40	40.0	32.0	6	51	E1191.3/4NO9
2"	11	59.61	160	40	45.0	35.0	6	57	E1192NO3
2"	11	59.61	160	40	45.0	35.0	6	57	E1192NO9
2.1/4	11	65.71	160	40	50.0	39.0	6	63	E1192.1/4NO3
2.1/4	11	65.71	160	40	50.0	39.0	6	63	E1192.1/4NO9
2.1/2	11	75.18	160	40	50.0	39.0	6	72.5	E1192.1/2NO3
2.1/2	11	75.18	160	40	50.0	39.0	6	72.5	E1192.1/2NO9
2.3/4	11	81.53	160	40	50.0	39.0	8	79	E1192.3/4NO3
2.3/4	11	81.53	160	40	50.0	39.0	8	79	E1192.3/4NO9
3"	11	87.88	160	40	50.0	39.0	8	85.5	E1193NO3
3"	11	87.88	160	40	50.0	39.0	8	85.5	E1193NO9

E282

- G(BSP) Maschi a macchina Scanalature diritte
- G(BSP) Maschinen-Gewindebohrer, geradegenutet
- G(BSP) Machinetap met rechte spaangroeven
- G(BSP) Tarauds machine Goujures droites

Fornito in HSS-E fino a nuovo stock
 Lieferung in HSS-E bis neuer Lagerbestand verfügbar ist
 Geleverd in HSS-E tot de nieuwe voorraad beschikbaar is
 Fourni en HSS-E jusqu'à ce que le nouveau stock soit disponible

E282 • 1.1 1.2 1.3 1.4 1.5 3.1 3.2 3.3 6.2 6.3 7.2 7.3 8.2

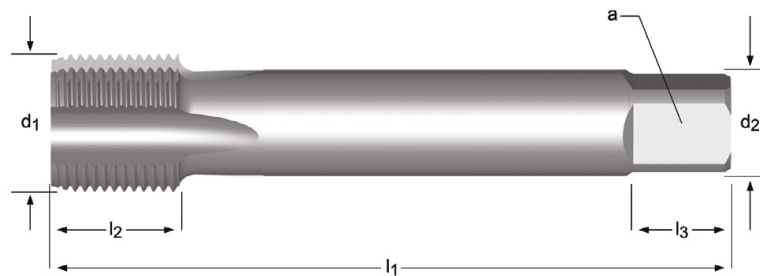

E282 **G** **DIN 5156** Normal **1.5XD** **HSS-E PM** **C 2-3**





G(BSP)	TPI	d ₁ nom mm	l ₁ mm	l ₂ mm	d ₂ Ø mm	∠ a mm	l ₃ mm	z		E282
1/8	28	9.73	90	20	7.0	5.5	8	3	8.8	E2821/8
1/4	19	13.16	100	21	11.0	9.0	12	4	11.8	E2821/4
3/8	19	16.66	100	21	12.0	9.0	12	4	15.25	E2823/8
1/2	14	20.96	125	24	16.0	12.0	15	4	19.0	E2821/2
3/4	14	26.44	140	28	20.0	16.0	19	4	24.5	E2823/4
1"	11	33.25	160	30	25.0	20.0	23	4	30.75	E2821
1.1/4	11	41.91	170	30	32.0	24.0	27	4	39.5	E2821.1/4 ¹⁾
1.1/2	11	47.80	190	32	36.0	29.0	32	6	45.0	E2821.1/2 ¹⁾

- E547**
- G(BSP) Maschi a macchina Scanalature diritte
 - G(BSP) Maschinen-Gewindebohrer, geradegenutet
 - G(BSP) Machinetap met rechte spaangroeven
 - G(BSP) Tarauds machine Goujures droites

E547 • 1.1 1.2 1.3 1.4 1.5 3.1 3.2 3.3 3.4 6.1 6.2 6.3 6.4 7.2 7.3 7.4 8.2 8.3

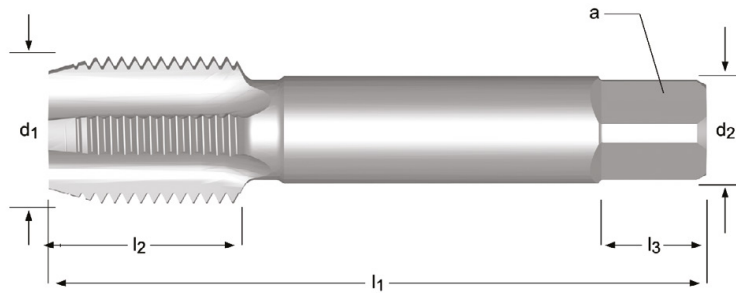
E547 **G** **ISO 2284** Normal  **1.5XD** **HSS**    



G(BSP)	TPI	d ₁ nom mm	l ₁ mm	l ₂ mm	d ₂ Ø mm	□ a mm	l ₃ mm	z		E547
1/8	28	9.728	59	15	8.0	8.0	9	4	8.8	E5471/8NO1
1/8	28	9.728	59	15	8.0	6.3	9	4	8.8	E5471/8NO2
1/8	28	9.728	59	15	8.0	6.3	9	4	8.8	E5471/8NO3
1/8	28	9.728	59	15	8.0	6.3	9	4	8.8	E5471/8NO7
1/4	19	13.157	67	19	10.0	8.0	11	4	11.8	E5471/4NO1
1/4	19	13.157	67	19	10.0	8.0	11	4	11.8	E5471/4NO2
1/4	19	13.157	67	19	10.0	8.0	11	4	11.8	E5471/4NO3
1/4	19	13.157	67	19	10.0	8.0	11	4	11.8	E5471/4NO7
3/8	19	16.662	75	21	12.5	10.0	13	4	15.25	E5473/8NO1
3/8	19	16.662	75	21	12.5	10.0	13	4	15.25	E5473/8NO2
3/8	19	16.662	75	21	12.5	10.0	13	4	15.25	E5473/8NO3
3/8	19	16.662	75	21	12.5	10.0	13	4	15.25	E5473/8NO7
1/2	14	20.955	87	26	16.0	12.5	16	4	19	E5471/2NO1
1/2	14	20.955	87	26	16.0	12.5	16	4	19	E5471/2NO2
1/2	14	20.955	87	26	16.0	12.5	16	4	19	E5471/2NO3
1/2	14	20.955	87	26	16.0	12.5	16	4	19	E5471/2NO7
5/8	14	22.911	91	26	18.0	14.0	18	4	21	E5475/8NO1
5/8	14	22.911	91	26	18.0	14.0	18	4	21	E5475/8NO2
5/8	14	22.911	91	26	18.0	14.0	18	4	21	E5475/8NO3
5/8	14	22.911	91	26	18.0	14.0	18	4	21	E5475/8NO7
3/4	14	26.441	96	28	20.0	16.0	20	4	24.5	E5473/4NO1
3/4	14	26.441	96	28	20.0	16.0	20	4	24.5	E5473/4NO2
3/4	14	26.441	96	28	20.0	16.0	20	4	24.5	E5473/4NO3
3/4	14	26.441	96	28	20.0	16.0	20	4	24.5	E5473/4NO7
7/8	14	30.201	102	29	22.4	18.0	22	4	28.25	E5477/8NO1
7/8	14	30.201	102	29	22.4	18.0	22	4	28.25	E5477/8NO2
7/8	14	30.201	102	29	22.4	18.0	22	4	28.25	E5477/8NO3
1"	11	33.249	109	33	25.0	20.0	24	4	30.75	E5471NO1
1"	11	33.249	109	33	25.0	20.0	24	4	30.75	E5471NO2
1"	11	33.249	109	33	25.0	20.0	24	4	30.75	E5471NO3
1.1/4	11	41.910	119	36	31.5	25.0	28	6	39.5	E5471.1/4NO1
1.1/4	11	41.910	119	36	31.5	25.0	28	6	39.5	E5471.1/4NO2
1.1/4	11	41.910	119	36	31.5	25.0	28	6	39.5	E5471.1/4NO3
1.1/2	11	47.803	125	37	35.5	28.0	31	6	45	E5471.1/2NO1
1.1/2	11	47.803	125	37	35.5	28.0	31	6	45	E5471.1/2NO2
1.1/2	11	47.803	125	37	35.5	28.0	31	6	45	E5471.1/2NO3
2"	11	59.614	140	41	40.0	31.5	34	6	57	E5472NO1
2"	11	59.614	140	41	40.0	31.5	34	6	57	E5472NO2
2"	11	59.614	140	41	40.0	31.5	34	6	57	E5472NO3

EP40 EP41

- G(BSP) Maschi a macchina imbocco corretto
- G(BSP) Maschinen-Gewindebohrer, geradegenutet mit Schälanschnitt
- G(BSP) Machinetap met schilaansnijding
- G(BSP) Tarauds machine Coupe gun

Fornito in HSS-E fino a nuovo stock
 Lieferung in HSS-E bis neuer Lagerbestand verfügbar ist
 Geleverd in HSS-E tot de nieuwe voorraad beschikbaar is
 Fourni en HSS-E jusqu'à ce que le nouveau stock soit disponible

EP40	▪	1.1	1.2	1.3	1.4	1.5	6.1	6.3	7.1	7.2	7.3	7.4	
	•	1.6	3.1	3.2	3.3	3.4	4.1	4.2	5.1	5.2	6.2	8.1	
EP41	▪	1.1	1.2	1.3	1.4	1.5							
	•	1.6	2.1	2.2	2.3	3.1	3.2	3.3	3.4				

EP40	G	DIN 5156	Normal		2.5XD	HSS-E PM	B 3.5-5				
EP41	G	DIN 5156	Normal		2.5XD	HSS-E PM	B 3.5-5			ST	

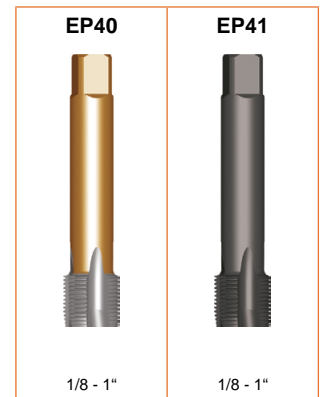
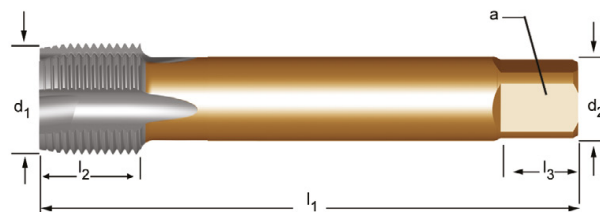

G(BSP)	TPI	d ₁ nom mm	l ₁ mm	l ₂ mm	d ₂ ∅ mm	□ a mm	l ₃ mm	z		EP40	EP41
1/8	28	9.728	90	18	7.0	5.5	8	3	8.8	EP401/8	EP411/8
1/4	19	13.157	100	21	11.0	9.0	12	3	11.8	EP401/4	EP411/4
3/8	19	16.662	100	21	12.0	9.0	12	4	15.25	EP403/8	EP413/8
1/2	14	20.955	125	24	16.0	12.0	15	4	19.0	EP401/2	EP411/2
5/8	14	22.911	125	24	18.0	14.5	17	4	21	EP405/8	EP415/8
3/4	14	26.441	140	28	20.0	16.0	19	4	24.5	EP403/4	EP413/4
7/8	14	30.201	150	28	22.0	18.0	21	4	28.25	EP407/8	EP417/8
1"	11	33.249	160	30	25.0	20.0	23	4	30.75	EP401	EP411

E041

- G(BSP) Maschi a macchina imbocco corretto
- G(BSP) Maschinen-Gewindebohrer, geradegenutet mit Schälanschnitt
- G(BSP) Machinetap met schilaansnijding
- G(BSP) Tarauds machine Coupe gun

Fornito in HSS-E fino a nuovo stock
 Lieferung in HSS-E bis neuer Lagerbestand verfügbar ist
 Geleverd in HSS-E tot de nieuwe voorraad beschikbaar is
 Fourni en HSS-E jusqu'à ce que le nouveau stock soit disponible

E041	▪	1.1	1.2	1.3	1.4	1.5			
	•	1.6	2.1	2.2	2.3	3.1	3.2	3.3	3.4

E041

G



Normal



2.5XD

HSS-E
PM

B
3.5-5

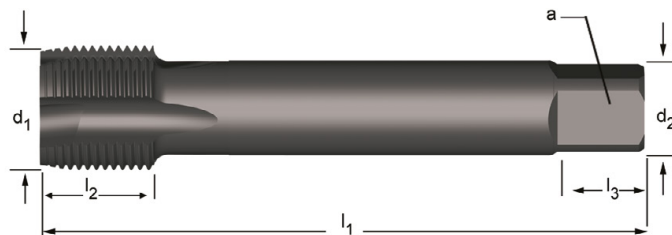

E041



1/8 - 3/4

G(BSP)	TPI	d ₁ nom mm	l ₁ mm	l ₂ mm	d ₂ Ø mm	∠ a mm	l ₃ mm	z		E041
1/8	28	9.728	90	15	8.0	6.3	9	3	8.80	E0411/8
1/4	19	13.157	100	19	10.0	8.0	11	3	11.80	E0411/4
3/8	19	16.662	100	21	12.5	10.0	13	3	15.25	E0413/8
1/2	14	20.955	125	26	16.0	12.5	16	4	19.00	E0411/2
3/4	14	26.441	140	28	20.0	16.0	20	4	24.50	E0413/4

EX40 EX41

- G(BSP) Maschi a macchina Scanalature elicoidali 45°
- G(BSP) Maschinen-Gewindebohrer, rechtsgedrallte Nuten 45°
- G(BSP) Machinetap met gespiraliseerde spaangroeven 45°
- G(BSP) Tarauds machine goujures hélicoïdales 45°

Fornito in HSS-E fino a nuovo stock

Lieferung in HSS-E bis neuer Lagerbestand verfügbar ist

Geleverd in HSS-E tot de nieuwe voorraad beschikbaar is

Fourni en HSS-E jusqu'à ce que le nouveau stock soit disponible

EX40	▪	1.1	1.2	1.3	1.4	1.5	7.1	7.2	7.3	7.4
	•	4.1	4.2	5.1	5.2	8.1				
EX41	▪	1.1	1.2	1.3	1.4	1.5	2.1	2.2		
	•	2.3								

EX40	G	DIN 5156	Normal		2.5XD	HSS-E PM	C 2-3		$\lambda 45^\circ$			
EX41	G	DIN 5156	Normal		2.5XD	HSS-E PM	C 2-3		$\lambda 45^\circ$		ST	

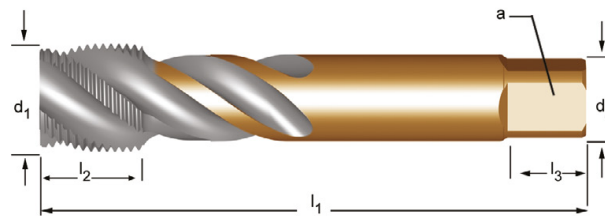

G(BSP)	TPI	d ₁ nom mm	l ₁ mm	l ₂ mm	d ₂ Ø mm	□ a mm	l ₃ mm	z		EX40	EX41
1/8	28	9.728	90	13	7.0	5.5	8	3	8.8	EX401/8	EX411/8
1/4	19	13.157	100	15	11.0	9.0	12	3	11.8	EX401/4	EX411/4
3/8	19	16.662	100	15	12.0	9.0	12	4	15.25	EX403/8	EX413/8
1/2	14	20.955	125	18	16.0	12.0	15	4	19.0	EX401/2	EX411/2
5/8	14	22.911	125	18	18.0	14.5	17	4	21	EX405/8	EX415/8
3/4	14	26.441	140	20	20.0	16.0	19	4	24.5	EX403/4	EX413/4
7/8	14	30.201	150	20	22.0	18.0	21	4	28.25	EX407/8	EX417/8
1"	11	33.249	160	22	25.0	20.0	23	4	30.75	EX401	EX411
1.1/8	11	37.897	170	22	28.0	22.0	25	4	35	EX401.1/8	EX411.1/8
1.1/4	11	41.910	170	22	32.0	24.0	27	4	39.5	EX401.1/4	¹⁾ EX411.1/4
1.1/2	11	47.803	190	23	36.0	29.0	32	4	45	EX401.1/2	¹⁾ EX411.1/2

E382

- G(BSP) Maschi a macchina Scanalature elicoidali 40°, Blue Shark
- G(BSP) Maschinen-Gewindebohrer, rechtsgedrallte Nuten 40°, Blauring Shark
- G(BSP) Machinetap, spiraalgroeven 40°, Blauwring Shark
- G(BSP) Tarauds machine goujures hélicoïdales 40°, Shark bague bleue

E382 ■ 2.1 2.2 2.3
 • 1.5

E382 **G** **DIN 5156** Normal **2XD** **HSS-E PM** **C 2-3** **λ40°** **ST**

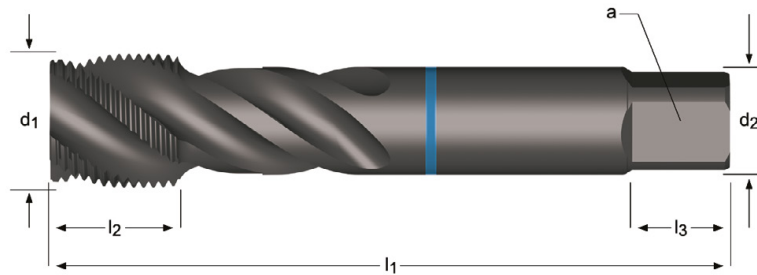

G(BSP)	TPI	d ₁ nom mm	l ₁ mm	l ₂ mm	d ₂ ∅ mm	∠ a mm	l ₃ mm	z		E382
1/8	28	9.73	90	12	7.0	5.5	8	3	8.8	E3821/8
1/4	19	13.16	100	15	11.0	9.0	12	4	11.8	E3821/4
3/8	19	16.66	100	15	12.0	9.0	12	4	15.25	E3823/8
1/2	14	20.96	125	24	16.0	12.0	15	4	19.0	E3821/2
3/4	14	26.44	140	20	20.0	16.0	19	4	24.5	E3823/4
1"	11	33.25	160	24	25.0	20.0	23	4	30.75	E3821

E043

- G(BSP) Maschi a macchina Scanalature elicoidali 45°
- G(BSP) Maschinen-Gewindebohrer, rechtsgedallte Nuten 45°
- G(BSP) Machinetap met gespiraliseerde spaangroeven 45°
- G(BSP) Tarauds machine goujures hélicoïdales 45°

Fornito in HSS-E fino a nuovo stock
 Lieferung in HSS-E bis neuer Lagerbestand verfügbar ist
 Geleverd in HSS-E tot de nieuwe voorraad beschikbaar is
 Fourni en HSS-E jusqu'à ce que le nouveau stock soit disponible

E043	▪	1.1	1.2	1.3	1.4	1.5
	•	1.6	2.1	2.2	2.3	

E043 **G** **Normal** **HSS-E PM** **C 2-3**

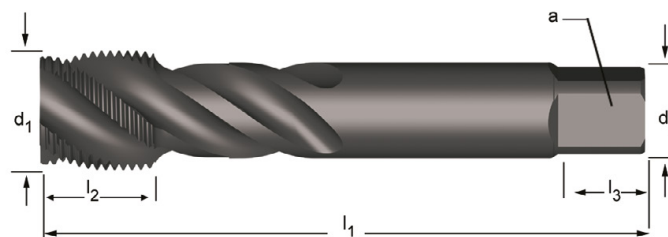

G(BSP)	TPI	d ₁ nom mm	l ₁ mm	l ₂ mm	d ₂ ∅ mm	∠ a mm	l ₃ mm	z		E043
1/8	28	9.728	90	15	8.0	6.3	9	3	8.80	E0431/8
1/4	19	13.157	100	19	10.0	8.0	11	3	11.80	E0431/4
3/8	19	16.662	100	21	12.5	10.0	13	4	15.25	E0433/8
1/2	14	20.955	125	26	16.0	12.5	16	4	19.00	E0431/2
3/4	14	26.441	140	28	20.0	16.0	20	4	24.50	E0433/4

E620

- EGM Maschi a macchina Scanalature diritte
- EGM Maschinen-Gewindebohrer, geradegenutet
- EGM Machinetap met rechte spaangroeven
- EGM Tarauds machine Goujures droites

E620 • 1.1 1.2 1.3 1.4 1.5 3.1 3.2 3.3 3.4 6.1 6.2 6.3 6.4 7.2 7.3 7.4 8.2 8.3

E620 EGM

DORMER
ISO

6H



1.5XD

HSS

C
2-3

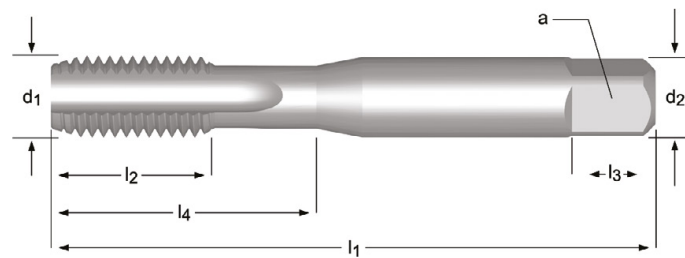

E620



M3 - M16

M	P mm	d ₁ nom mm	l ₁ mm	l ₂ mm	d ₂ ∅ mm	∠ a mm	l ₃ mm	z		l ₄ mm	E620
3	0.50	3.65	53	14	4.0	3.15	6	3	3.2	14	E620M3
4	0.70	4.91	58	11	5.0	4.00	7	3	4.2	20	E620M4
5	0.80	6.04	66	13	6.3	5.00	8	3	5.2	26	E620M5
6	1.00	7.30	72	16	8.0	6.30	9	3	6.3	29	E620M6
8	1.25	9.62	80	18	10.0	8.00	11	3	8.4	32	E620M8
10	1.50	11.95	89	22	9.0	7.10	10	3	10.5	-	E620M10
12	1.75	14.27	95	24	11.2	9.00	12	4	12.5	-	E620M12
14	2.00	16.60	112	29	14.0	11.20	14	4	14.5	-	E620M14
16	2.00	18.60	112	29	14.0	11.20	14	4	16.5	-	E620M16

- E621**
- EGM Maschi a macchina Scanalature elicoidali 40°
 - EGM Maschinen-Gewindebohrer, rechtsgedrallte Nuten 40°
 - EGM Machinetap met gespiraliseerde spaangroeven 40°
 - EGM Tarauds machine goujures hélicoidales 40°

E621 • 1.2 1.3 1.4 1.5 2.1 2.2 2.3 5.2 7.1 7.2 7.3 7.4

E621 EGM 6H 2XD HSS C 2-3

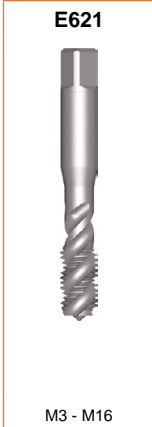
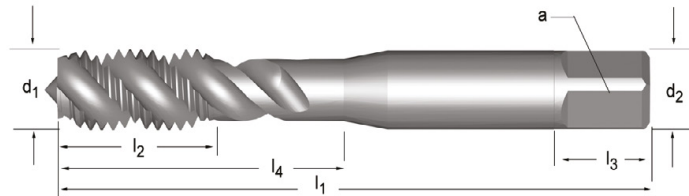

M	P mm	d ₁ nom mm	l ₁ mm	l ₂ mm	d ₂ Ø mm	∠ a mm	l ₃ mm	z		l ₄ mm	E621
3	0.50	3.65	53	14	4.00	3.15	6	3	↔	14	E621M3
4	0.70	4.91	58	11	5.00	4.00	7	3	↔	20	E621M4
5	0.80	6.04	66	13	6.30	5.00	8	3	↔	26	E621M5
6	1.00	7.3	72	16	8.00	6.30	9	3	↔	31	E621M6
8	1.25	9.62	80	18	10.00	8.00	11	3	↔	34	E621M8
10	1.50	11.95	89	22	9.00	7.10	10	3	↔	-	E621M10
12	1.75	14.27	95	24	11.20	9.00	12	3	↔	-	E621M12
14	2.00	16.6	112	29	14.00	11.20	14	3	↔	-	E621M14
16	2.00	18.6	112	29	14.00	11.20	14	3	↔	-	E621M16

E550

- Rc Maschi a macchina Scanalature diritte
- Rc Maschinen-Gewindebohrer, geradegenutet
- Rc Hand-/machinetap met rechte spaangroeven
- Rc Tarauds machine Goujures droite

E550	▪	3.1	3.2	3.3	3.4	6.1												
	•	1.1	1.2	1.3	1.4	1.5	1.6	2.1	2.2	2.3	6.2	6.3	6.4	7.2	7.3	7.4	8.2	8.3

E550 **Rc** **ISO 2284** Normal  **1.5XD** **HSS** **C 2-3**    

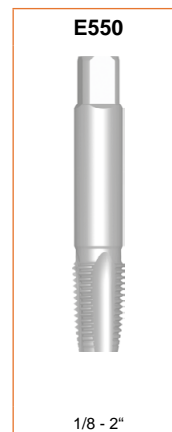
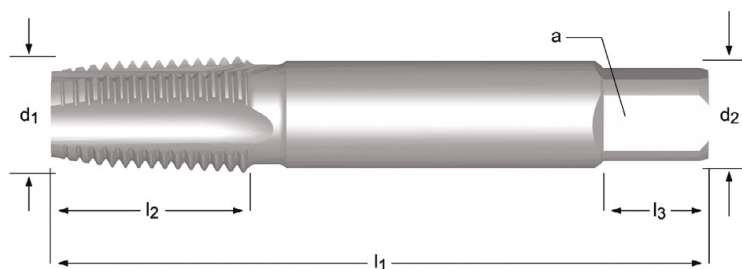

Rc	TPI	d ₁ nom mm	l ₁ mm	l ₂ mm	d ₂ ∅ mm	a mm	l ₃ mm	z		E550
1/8	28	9.728	59	15	8.0	6.3	9	3	8.4	E5501/8
1/8	28	9.728	59	15	8.0	6.3	9	3	8.4	E5501/8NO7
1/4	19	13.157	67	19	10.0	8.0	11	3	11.2	E5501/4
1/4	19	13.157	67	19	10.0	8.0	11	3	11.2	E5501/4NO7
3/8	19	16.662	75	21	12.5	10.0	13	3	14.75	E5503/8
3/8	19	16.662	75	21	12.5	10.0	13	3	14.75	E5503/8NO7
1/2	14	20.955	87	26	16.0	12.5	16	5	18.25	E5501/2
1/2	14	20.955	87	26	16.0	12.5	16	5	18.25	E5501/2NO7
3/4	14	26.441	96	28	20.0	16.0	20	5	23.75	E5503/4
3/4	14	26.441	96	28	20.0	16.0	20	5	23.75	E5503/4NO7
1"	11	33.249	109	33	25.0	20.0	24	5	30	E5501
1.1/4	11	41.910	119	36	31.5	25.0	28	5	38.5	E5501.1/4
1.1/2	11	47.803	125	37	35.5	28.0	31	7	44.5	E5501.1/2
2"	11	59.614	140	41	40.0	31.5	34	7	56	E5502

NO1 - NO9
219

E714

- NPT Maschi a macchina Scanalature diritte
- NPT Maschinen-Gewindebohrer, geradegenutet
- NPT Machinetap met rechte spaangroeven
- NPT Tarauds machine Goujures droites

Fornito in HSS-E fino a nuovo stock
 Lieferung in HSS-E bis neuer Lagerbestand verfügbar ist
 Geleverd in HSS-E tot de nieuwe voorraad beschikbaar is
 Fourni en HSS-E jusqu'à ce que le nouveau stock soit disponible

E714	▪	1.3	1.4																
	•	1.1	1.2	1.5	3.1	3.2	3.3	3.4	6.2	7.3	7.4	8.1							



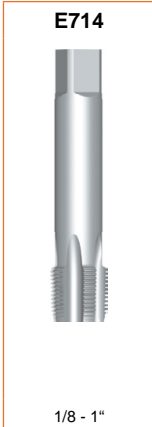
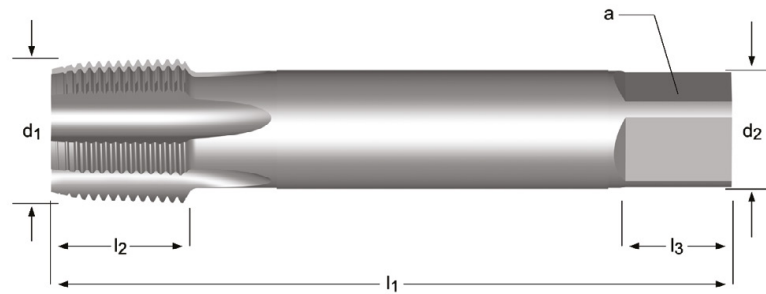







E714 **NPT** **Normal** **HSS-E PM** **C 2-3**





NPT	TPI	d ₁ nom mm	l ₁ mm	l ₂ mm	d ₂ ∅ mm	∠ a mm	l ₃ mm	z		E714
1/8	27	10.23	90	14	11.0	9.0	12	3	8.5	E7141/8
1/4	18	13.60	100	20	14.0	11.0	14	3	11	E7141/4
3/8	18	17.04	110	20	16.0	12.0	15	4	14.5	E7143/8
1/2	14	21.20	125	26	18.0	14.5	17	4	18	E7141/2
3/4	14	26.54	140	26	22.0	18.0	21	5	23	E7143/4
1"	11.5	33.20	150	31	28.0	22.0	25	5	29	E7141

- E710** • NPT Maschi a macchina Scanalature diritte
 • NPT Maschinen-Gewindebohrer, geradegenutet
- E721** • NPT Machinetap met rechte spaangroeven
 • NPT Tarauds machine Goujures droites

E710	•	1.1	1.2	1.3	1.4	1.5	3.1	3.2	3.3	3.4	6.2	7.3	7.4	8.1
E721	▪	1.3	1.4	3.1	3.2	3.3	3.4							
	•	1.1	1.2	1.5	6.2	7.3	7.4	8.1						

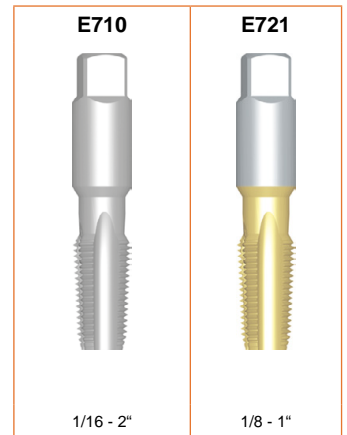
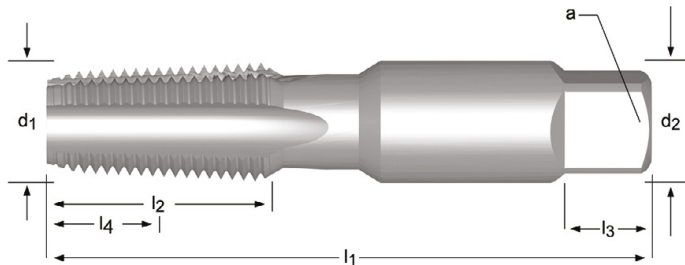
E710	NPT	ANSI B94.9	Normal		1.5XD	HSS	C 2-3				
E721	NPT	ANSI B94.9	Normal		1.5XD	HSS	C 2-3				



NPT	TPI	d ₁ nom mm	l ₁ mm	l ₂ mm	l ₄ mm	d ₂ Ø mm	□ a mm	l ₃ mm	z		E710	E721
1/16	27	7.94	65	17	11.7	8.1	6.0	8	4	6.3	E7101/16NO3	
1/8	27	10.29	70	19	11.9	11.1	8.3	10	4	8.5	E7101/8	E7211/8
1/8	27	10.29	70	19	11.9	11.1	8.3	10	4	8.5	E7101/8NO7	
1/4	18	13.72	75	27	17.6	14.3	10.7	11	4	11.0	E7101/4	E7211/4
1/4	18	13.72	75	27	17.6	14.3	10.7	11	4	11.0	E7101/4NO7	
3/8	18	17.15	80	27	19.5	17.8	13.5	13	4	14.5	E7103/8	E7213/8
3/8	18	17.15	80	27	19.5	17.8	13.5	13	4	14.5	E7103/8NO7	
1/2	14	21.34	100	35	22.7	17.5	13.1	16	4	18.0	E7101/2	E7211/2
1/2	14	21.34	100	35	22.7	17.5	13.1	16	4	18.0	E7101/2NO7	
3/4	14	26.67	105	35	24.4	23.0	17.2	17	5	23.0	E7103/4	E7213/4
3/4	14	26.67	105	35	24.4	23.0	17.2	17	5	23.0	E7103/4NO7	
1"	11.5	33.40	115	43	29.4	28.6	21.4	21	5	29.0	E7101	E7211
1.1/4	11.5	42.16	125	43	27.7	33.3	25.0	24	5	38.0	E7101.1/4	
1.1/2	11.5	48.26	135	43	28.9	38.1	28.6	25	7	44.0	E7101.1/2	
2"	11.5	60.33	145	43	26.6	47.6	35.7	29	7	56.0	E7102	

NO1 - NO9

 219

E711

- NPT Maschi a macchina, filettatura alternata Scanalature dritte
- NPT Maschinen-Gewindebohrer, ausgesetzte Zähne, geradegenutet
- NPT Machinetap met rechte spaangroeven en onderbroken vertanding
- NPT Tarauds machine Goujures droites

E711 ■ 1.3 1.4
 • 1.1 1.2 1.5 3.1 3.2 3.3 3.4 6.2 7.3 7.4 8.1

E711 NPT ANSI B94.9 Normal 1.5XD HSS C 2-3

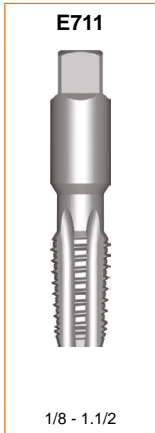
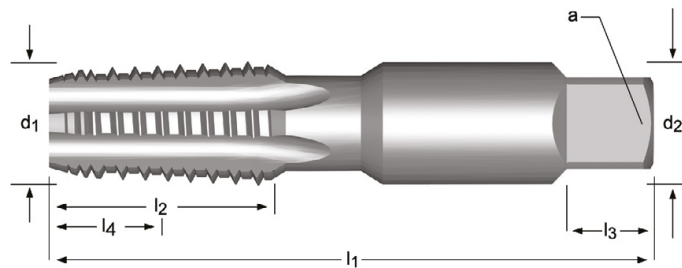

NPT	TPI	d ₁ nom mm	l ₁ mm	l ₂ mm	l ₄ mm	d ₂ ∅ mm	□ a mm	l ₃ mm	z		E711
1/8	27	10.29	70	19	11.9	11.1	8.3	10	5	8.5	E7111/8
1/4	18	13.72	75	27	17.6	14.3	10.7	11	5	11.0	E7111/4
3/8	18	17.15	80	27	19.5	17.8	13.5	13	5	14.5	E7113/8
1/2	14	21.33	100	35	22.7	17.5	13.1	16	5	18.0	E7111/2
3/4	14	26.67	105	35	24.4	23.0	17.2	17	5	23.0	E7113/4
1"	11.5	33.40	115	43	29.4	28.6	21.4	21	5	29.0	E7111
1.1/2	11.5	48.26	135	43	28.9	38.1	28.6	25	7	44.0	E7111.1/2

E653

- NPT Punta a maschiare Scanalature elicoidali 27°
- NPT Kombi-Gewindebohrer, rechtsgedrahte Nuten 27°
- NPT Combi boortap met gespiraliseerde spaangroeven 27°
- NPT Foret tarauteur goujures hélicoïdales 27°

E653 • 1.1 1.2 1.3 1.4 3.2 6.2 6.3 7.1 7.2 8.1

E653 NPT ANSI Normal 1.5XD HSS $\lambda 27^\circ$

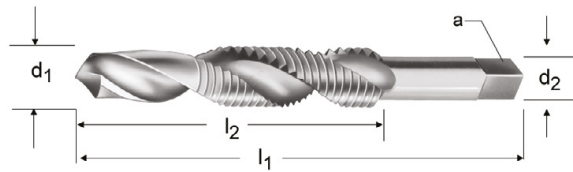

E653



1/8 - 1"

NPT	TPI	d ₁ nom Inch	l ₁ Inch	l ₂ Inch	d ₂ ∅ Inch	∠ a Inch	z	E653
1/8	27	0.3346	2.7/8	3/4	0.4370	0.3280	2	E6531/8
1/4	18	0.4331	3.5/16	1.1/16	0.5620	0.4210	2	E6531/4
3/8	18	0.5709	3.1/2	1.1/16	0.7000	0.5310	2	E6533/8
1/2	14	0.7087	4.3/8	1.3/8	0.6870	0.5150	2	E6531/2
3/4	14	0.9055	4.9/16	1.3/8	0.9060	0.6790	2	E6533/4
1"	11.5	1.1417	5.3/8	1.3/4	1.1250	0.8430	2	E6531

- E712**
- NPTF Maschi a macchina Scanalature diritte
 - NPTF Maschinen-Gewindebohrer, geradegenutet
 - NPTF Machinetap met rechte spaangroeven
 - NPTF Tarauds machine Goujures droites

E712 ■ 1.3 1.4
 • 1.1 1.2 1.5 3.1 3.2 3.3 3.4 6.2 7.3 7.4 8.1



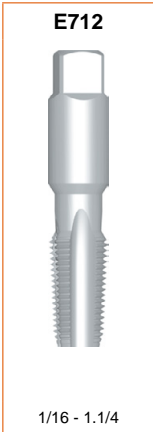
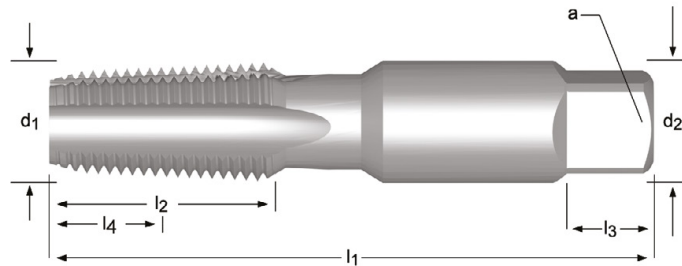

E712 NPTF ANSI B94.9 Normal 1.5XD HSS C 2-3





NPTF	TPI	d ₁ nom mm	l ₁ mm	l ₂ mm	l ₄ mm	d ₂ ∅ mm	∠ a mm	l ₃ mm	z		E712
1/16	27	7.94	65	17	11.7	8.1	6.0	8	4	6.20	E7121/16
1/8	27	10.29	70	19	11.9	11.1	8.3	10	4	8.40	E7121/8
1/4	18	13.72	75	27	17.6	14.3	10.7	11	4	10.90	E7121/4
3/8	18	17.15	80	27	19.5	17.8	13.5	13	4	14.25	E7123/8
1/2	14	21.34	100	35	22.7	17.5	13.1	16	4	17.75	E7121/2
3/4	14	26.67	105	35	24.4	23.0	17.2	17	5	23.00	E7123/4
1"	11.5	33.40	115	43	29.4	28.6	21.4	21	5	29.00	E7121
1.1/4	11.5	42.16	125	43	27.7	33.4	24.9	23	5	37.75	E7121.1/4

- E709** • NPSF Maschi a macchina Scanalature diritte
 • NPSF Maschinen-Gewindebohrer, geradegenutet
- E720** • NPSF Machinetap met rechte spaangroeven
 • NPSF Tarauds machine Goujures droites

E709	▪	1.3	1.4																
	•	1.1	1.2	1.5	3.1	3.2	3.3	3.4	6.2	7.3	7.4	8.1							
E720	▪	1.3	1.4	3.1	3.2	3.3	3.4												
	•	1.1	1.2	1.5	6.2	7.3	7.4	8.1											

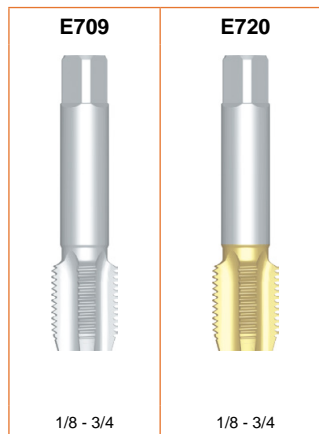
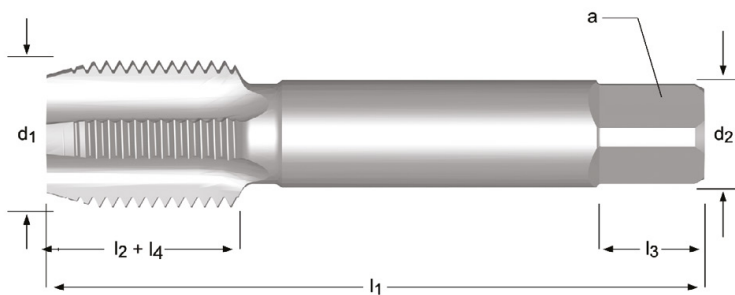
E709	NPSF	ANSI B94.9	Normal		1.5XD	HSS	C 2-3				
E720	NPSF	ANSI B94.9	Normal		1.5XD	HSS	C 2-3				TiN



NPSF	TPI	d ₁ nom mm	l ₁ mm	l ₂ mm	l ₄ mm	d ₂ Ø mm	□ a mm	l ₃ mm	z		E709	E720
1/8	27	10.29	70	19	19	11.1	8.3	10	4	8.70	E7091/8	E7201/8NO3
1/4	18	13.72	75	27	27	14.3	10.7	11	4	11.30	E7091/4	E7201/4NO3
3/8	18	17.15	80	27	27	17.8	13.5	13	4	14.75	E7093/8	E7203/8NO3
1/2	14	21.34	100	35	-	17.5	13.1	16	4	18.25	E7091/2	E7201/2NO3
3/4	14	26.67	105	35	-	23.0	17.2	17	5	23.50	E7093/4	E7203/4NO3

N01 - N09

 219

- # E708
- NPSM Maschi a macchina Scanalature diritte
 - NPSM Maschinen-Gewindebohrer, geradegenutet
 - NPSM Machinetap met rechte spaangroeven
 - NPSM Tarauds machine Goujures droites

E708 ■ 1.3 1.4
 • 1.1 1.2 1.5 3.1 3.2 3.3 3.4 6.2 7.3 7.4 8.1

E708 NPSM ANSI B94.9 Normal 1.5XD HSS C 2-3

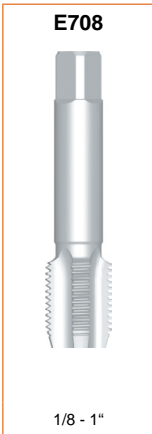
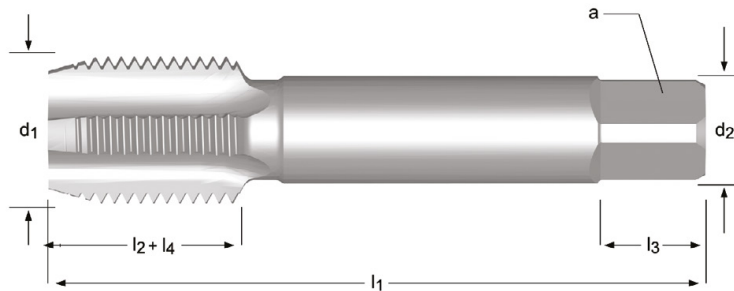

NPSM	TPI	d ₁ nom mm	l ₁ mm	l ₂ mm	l ₄ mm	d ₂ Ø mm	□ a mm	l ₃ mm	z		E708
1/8	27	10.29	70	19	19	11.1	8.3	10	4	9.1	E7081/8
1/4	18	13.72	75	27	27	14.3	10.7	11	4	12.0	E7081/4
3/8	18	17.15	80	27	27	17.8	13.5	13	4	15.5	E7083/8
1/2	14	21.33	100	35	-	17.5	13.1	16	4	19.0	E7081/2
3/4	14	26.67	105	35	-	23.0	17.2	17	5	24.5	E7083/4
1"	11.5	33.40	115	43	-	28.6	21.4	21	5	30.5	E7081

E243

- PG Maschi a macchina Scanalature diritte
- PG Hand-/Maschinen-Gewindebohrer, geradegenutet
- PG Hand-/machinetappen met rechte spaangroeven
- PG Taraulds machine Goujures droite

E243 • 1.1 1.2 1.3 1.4 1.5 3.1 3.2 3.3 6.2 6.3 7.2 7.3 8.2

E243

PG

DIN
40432

Normal



1.5XD

HSS

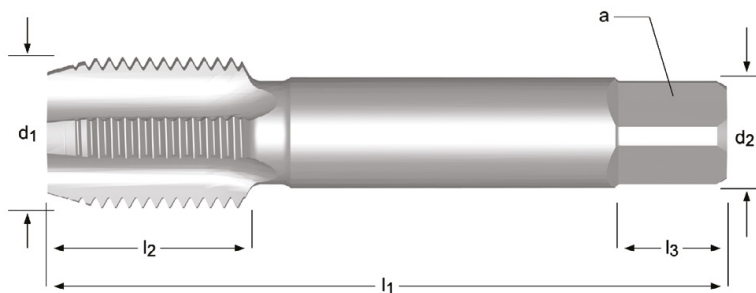

E243



No.7 - No.36

PG	TPI	d ₁ nom mm	l ₁ mm	l ₂ mm	d ₂ ∅ mm	∇ a mm	l ₃ mm	z		E243
7	20	12.5	70	22	9.0	7.0	10	4	11.4	E243PG7NO2
7	20	12.5	70	22	9.0	7.0	10	4	11.4	E243PG7NO3
9	18	15.2	70	22	12.0	9.0	12	4	13.9	E243PG9NO2
9	18	15.2	70	22	12.0	9.0	12	4	13.9	E243PG9NO3
11	18	18.6	80	22	14.0	11.0	14	4	17.25	E243PG11NO2
11	18	18.6	80	22	14.0	11.0	14	4	17.25	E243PG11NO3
13.5	18	20.4	80	22	16.0	12.0	15	4	19	E243PG13.5NO2
13.5	18	20.4	80	22	16.0	12.0	15	4	19	E243PG13.5NO3
16	18	22.5	80	22	18.0	14.5	17	4	21.25	E243PG16NO2
16	18	22.5	80	22	18.0	14.5	17	4	21.25	E243PG16NO3
21	16	28.3	90	22	22.0	18.0	21	4	27	E243PG21NO2
21	16	28.3	90	22	22.0	18.0	21	4	27	E243PG21NO3
29	16	37.0	100	25	28.0	22.0	25	6	35.5	E243PG29NO2
29	16	37.0	100	25	28.0	22.0	25	6	35.5	E243PG29NO3
36	16	47.0	140	32	36.0	29.0	32	6	45.5	E243PG36NO2
36	16	47.0	140	32	36.0	29.0	32	6	45.5	E243PG36NO3

N01 - N09



219

L119

- M Maschi a macchina Set
- Gewindebohrer Satz, in Metallkassette
- M Machinetappen in set
- Coffret métallique de tarauds pas métrique

A=Tipi in serie, B=No. punte in Set, M=diametri in Set
 A=Typen in Satz, B=Anzahl, M= Gewindebohrerdurchmesser im Satz
 A=Type, B=Aantal, M=Tappen diameters
 A=Types de coffrets, B=Nombre dans le coffret, M=Diamètres de tarauds dans le coffret



Set

L119

Set	A	B	M	
Nr.17	E100	21	E100M3NO8, E100M4NO8, E100M5NO8, E100M6NO8, E100M8NO8, E100M10NO8, E100M12NO8	L11917

L126

- Punta a maschiare, Set
- Kombi-Gewindebohrer in Metallkassette
- Draadsnijset, combi boortappen
- Jeu de forets taraudeurs

A=Tipi in serie, B=No. punte in Set, M=diametri in Set
 A=Typen in Satz, B=Anzahl, M= Gewindebohrerdurchmesser im Satz
 A=Type, B=Aantal, M=Tappen diameters
 A=Types de coffrets, B=Nombre dans le coffret, M=Diamètres de tarauds dans le coffret

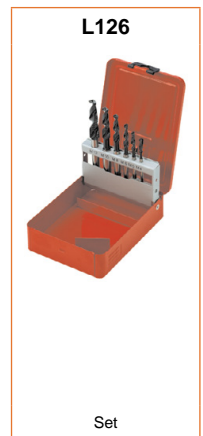

Set	A	B	M	L126
650	E650	6	E650M4, E650M5, E650M6, E650M8, E650M10, E650M12	L126650

L113

- ISO Maschi e Punte, Set
- ISO Gewinde-Kernlochbohrer Set
- ISO Draadsnijset, tappen en boren
- ISO Jeu de forets-tarauds

A= Tipologie in assortimento, B= Quantità, M= Gamma Maschi, D= Gamma Punte

A=Typen in Satz, B=Anzahl, M= Gewindebohrerdurchmesser im Satz, D= Bohrerdurchmesser im Satz

A=Type, B=Aantal, M=Tappen diameters, D= Boren diameters

A=Types de coffrets, B=Nombre dans le coffret, M=Diamètres de tarauds dans le coffret, D=Diamètres de forets dans le coffret



Set	A	B	M	D	L113
Nr.201	E000 + A002	14	E000M3, E000M4, E000M5, E000M6, E000M8, E000M10, E000M12	A0022.5, A0023.3, A0024.2, A0025.0, A0026.8, A0028.5, A00210.2	L113201
Nr.202	E001 + A002	14	E001M3, E001M4, E001M5, E001M6, E001M8, E001M10, E001M12	A0022.5, A0023.3, A0024.2, A0025.0, A0026.8, A0028.5, A00210.2	L113202
Nr.203	E002 + A002	14	E002M3, E002M4, E002M5, E002M6, E002M8, E002M10, E002M12	A0022.5, A0023.3, A0024.2, A0025.0, A0026.8, A0028.5, A00210.2	L113203
Nr.204	E003 + A002	14	E003M3, E003M4, E003M5, E003M6, E003M8, E003M10, E003M12	A0022.5, A0023.3, A0024.2, A0025.0, A0026.8, A0028.5, A00210.2	L113204

L114

- DIN Maschi e Punte, Set
- DIN Gewinde-Kernlochbohrer Set
- DIN Draadsnijset, tappen en boren
- DIN Jeu de forets-tarauds

A= Tipologie in assortimento, B= Quantità, M= Gamma Maschi, D= Gamma Punte

A=Typen in Satz, B=Anzahl, M= Gewindebohrerdurchmesser im Satz, D= Bohrerdurchmesser im Satz

A=Type, B=Aantal, M=Tappen diameters, D= Boren diameters





A=Types de coffrets, B=Nombre dans le coffret, M=Diamètres de tarauds dans le coffret, D=Diamètres de forets dans le coffret



L114



Set

Set	A	B	M	D	L114
Nr.301	EP006H + A002	14	EP00M3, EP00M4, EP00M5, EP00M6, EP00M8, EP00M10, EP00M12	A0022.5, A0023.3, A0024.2, A0025.0, A0026.8, A0028.5, A00210.2	L114301
Nr.302	EX006H + A002	14	EX00M3, EX00M4, EX00M5, EX00M6, EX00M8, EX00M10, EX00M12	A0022.5, A0023.3, A0024.2, A0025.0, A0026.8, A0028.5, A00210.2	L114302
Nr.303	E297 + A002 	14	E297M3, E297M4, E297M5, E297M6, E297M8, E297M10, E297M12	A0022.5, A0023.3, A0024.2, A0025.0, A0026.8, A0028.5, A00210.2	L114303
Nr.304	E298 + A002 	14	E298M3, E298M4, E298M5, E298M6, E298M8, E298M10, E298M12	A0022.5, A0023.3, A0024.2, A0025.0, A0026.8, A0028.5, A00210.2	L114304
Nr.305	E238 + A108 	14	E238M3, E238M4, E238M5, E238M6, E238M8, E238M10, E238M12	A1082.5, A1083.3, A1084.2, A1085.0, A1086.8, A1088.5, A10810.2	L114305
Nr.306	E240 + A108 	14	E240M3, E240M4, E240M5, E240M6, E240M8, E240M10, E240M12	A1082.5, A1083.3, A1084.2, A1085.0, A1086.8, A1088.5, A10810.2	L114306

L115

- Maschi a mano e Punte, Set
- Handgewindebohrer/ Kernlochbohrer Satz
- Handtappen/ boren set
- Jeu de forets-tarauds à mains

A= Tipologie in assortimento, B= Quantità, M= Gamma Maschi, D= Gamma Punte
 A=Typen in Satz, B=Anzahl, M= Gewindebohrerdurchmesser im Satz, D= Bohrer-
 erdurchmesser im Satz
 A=Type, B=Aantal, M=Tappen diameters, D= Boren diameters
 A=Types de coffrets, B=Nombre dans le coffret, M=Diamètres de tarauds dans le
 coffret, D=Diamètres de forets dans le coffret



Set

Set	A	B	M	D	L115
Nr.100	E500 + A022	21	E500M3NO2, E500M3NO3, E500M4NO2, E500M4NO3, E500M5NO2, E500M5NO3, E500M6NO2, E500M6NO3, E500M8NO2, E500M8NO3, E500M10NO2, E500M10NO3, E500M12NO2, E500M12NO3	A0222.5, A0223.3, A0224.2, A0225.0, A0226.8, A0228.5, A02210.2	L115100
Nr.101	E500 + A002	14	E500M3NO3, E500M4NO3, E500M5NO3, E500M6NO3, E500M8NO3, E500M10NO3, E500M12NO3	A0022.5, A0023.3, A0024.2, A0025.0, A0026.8, A0028.5, A00210.2	L115101

L000

- Set maschio a mano-punta (2 Pezzi)
- Hand-Gewindebohrer-Satz (2 Stück)
- Handtap-boor Set (2 st)
- Jeu de forets-tarauts à mains (2 pièces)

A= Tipologie in assortimento, B= Quantità, M= Gamma Maschi, D= Gamma Punta

A=Typen in Satz, B=Anzahl, M= Gewindebohrerdurchmesser im Satz, D= Bohrerdurchmesser im Satz

A=Type, B=Aantal, M=Tappen diameters, D= Boren diameters

A=Types de coffrets, B=Nombre dans le coffret, M=Diamètres de tarauds dans le coffret, D=Diamètres de forets dans le coffret



Nr.	A	B	M	D	L000
Nr.1	E500 + A002	2	E500M3NO2	A0022.5	L000E500M3NO2XA002
Nr.2	E500 + A002	2	E500M4NO2	A0023.3	L000E500M4NO2XA002
Nr.3	E500 + A002	2	E500M5NO2	A0024.2	L000E500M5NO2XA002
Nr.4	E500 + A002	2	E500M6NO2	A0025.0	L000E500M6NO2XA002
Nr.5	E500 + A002	2	E500M8NO2	A0026.8	L000E500M8NO2XA002
Nr.6	E500 + A002	2	E500M10NO2	A0028.5	L000E500M10NO2XA002
Nr.7	E500 + A002	2	E500M12NO2	A00210.2	L000E500M12NO2XA002
Nr.8	E500 + A002	2	E500M3NO3	A0022.5	L000E500M3NO3XA002
Nr.9	E500 + A002	2	E500M4NO3	A0023.3	L000E500M4NO3XA002
Nr.10	E500 + A002	2	E500M5NO3	A0024.2	L000E500M5NO3XA002
Nr.11	E500 + A002	2	E500M6NO3	A0025.0	L000E500M6NO3XA002
Nr.12	E500 + A002	2	E500M8NO3	A0026.8	L000E500M8NO3XA002
Nr.13	E500 + A002	2	E500M10NO3	A0028.5	L000E500M10NO3XA002
Nr.14	E500 + A002	2	E500M12NO3	A00210.2	L000E500M12NO3XA002

L001

- Set maschio DIN-punta (2 Pezzi)
- DIN-Gewindebohrer-Satz (2 Stück)
- DIN Tap-Boor Set (2 st)
- Jeu de forets-tarauds DIN (2 pièces)

A= Tipologie in assortimento, B= Quantità, M= Gamma Maschi, D= Gamma Punta

A=Typen in Satz, B=Anzahl, M= Gewindebohrerdurchmesser im Satz, D= Bohrerdurchmesser im Satz

A=Type, B=Aantal, M=Tappen diameters, D= Boren diameters

A=Types de coffrets, B=Nombre dans le coffret, M=Diamètres de tarauds dans le coffret, D=Diamètres de forets dans le coffret



Nr.	A	B	M	D	L001
Nr.1	EP006H + A002	2	EP00M3	A0022.5	L001EP00M3XA002
Nr.2	EP006H + A002	2	EP00M4	A0023.3	L001EP00M4XA002
Nr.3	EP006H + A002	2	EP00M5	A0024.2	L001EP00M5XA002
Nr.4	EP006H + A002	2	EP00M6	A0025.0	L001EP00M6XA002
Nr.5	EP006H + A002	2	EP00M8	A0026.8	L001EP00M8XA002
Nr.6	EP006H + A002	2	EP00M10	A0028.5	L001EP00M10XA002
Nr.7	EP006H + A002	2	EP00M12	A00210.2	L001EP00M12XA002
Nr.8	EX006H + A002	2	EX00M3	A0022.5	L001EX00M3XA002
Nr.9	EX006H + A002	2	EX00M4	A0023.3	L001EX00M4XA002
Nr.10	EX006H + A002	2	EX00M5	A0024.2	L001EX00M5XA002
Nr.11	EX006H + A002	2	EX00M6	A0025.0	L001EX00M6XA002
Nr.12	EX006H + A002	2	EX00M8	A0026.8	L001EX00M8XA002
Nr.13	EX006H + A002	2	EX00M10	A0028.5	L001EX00M10XA002
Nr.14	EX006H + A002	2	EX00M12	A00210.2	L001EX00M12XA002

L002

- Set maschio ISO-punta (2 Pezzi)
- ISO-Gewindebohrer-Satz (2 Stück)
- ISO Tap-Boor Set (2 st)
- Jeu de forets-tarauts ISO (2 pièces)

A= Tipologie in assortimento, B= Quantità, M= Gamma Maschi, D= Gamma Punte

A=Typen in Satz, B=Anzahl, M= Gewindebohrerdurchmesser im Satz, D= Bohrerdurchmesser im Satz

A=Type, B=Aantal, M=Tappen diameters, D= Boren diameters

A=Types de coffrets, B=Nombre dans le coffret, M=Diamètres de tarauds dans le coffret, D=Diamètres de forets dans le coffret



Nr.	A	B	M	D	L002
Nr.1	E000 + A002	2	E000M3	A0022.5	L002E000M3XA002
Nr.2	E000 + A002	2	E000M4	A0023.3	L002E000M4XA002
Nr.3	E000 + A002	2	E000M5	A0024.2	L002E000M5XA002
Nr.4	E000 + A002	2	E000M6	A0025.0	L002E000M6XA002
Nr.5	E000 + A002	2	E000M8	A0026.8	L002E000M8XA002
Nr.6	E000 + A002	2	E000M10	A0028.5	L002E000M10XA002
Nr.7	E000 + A002	2	E000M12	A00210.2	L002E000M12XA002
Nr.8	E002 + A002	2	E002M3	A0022.5	L002E002M3XA002
Nr.9	E002 + A002	2	E002M4	A0023.3	L002E002M4XA002
Nr.10	E002 + A002	2	E002M5	A0024.2	L002E002M5XA002
Nr.11	E002 + A002	2	E002M6	A0025.0	L002E002M6XA002
Nr.12	E002 + A002	2	E002M8	A0026.8	L002E002M8XA002
Nr.13	E002 + A002	2	E002M10	A0028.5	L002E002M10XA002
Nr.14	E002 + A002	2	E002M12	A00210.2	L002E002M12XA002

L120

- Filettatura attrezzatura, set
- Gewinde- Schneidsätze, Metallkassette
- Draadsnijgereedschapset
- Coffret métallique d'équipements de taraudage

A= Tipologie in assortimento, B= Quantità, M= Gamma Maschi, F= Gamma Filiere, L112= Giramaschio, L110= Girafilieri
 A=Typen in Satz, B=Anzahl, M= Gewindebohrerdurchmesser im Satz, F= Schneideisendurchmesser im Satz, L112= Verstellbares Windeisen im Satz, L110= Schneideisenhalter im Satz
 A=Type, B=Aantal, M=Tappen diameters, F= Snijplaten, L112= Wringijzers, verstelbaar, L110= Snijplaathouder
 A=Types de coffrets, B=Nombre dans le coffret, M=Diamètres de tarauds dans le coffret, F= Diamètres de filières dans le coffret, L112= Porte filières dans le coffret, L110= Tourne à gauche dans le coffret



Set	A	B	M	F	L112	L110	L120
21	E100 + F100 + L112 + L110	21	E100M3NO8, E100M4NO8, E100M5NO8, E100M6NO8, E100M8NO8, E100M10NO8, E100M12NO8	F100M3, F100M4, F100M5, F100M6, F100M8, F100M10, F100M12	L112NO1.1/2, L112NO3	L1102A, L1102B, L1103, L1104, L1105	L12021
30	E100 + F100 + L112 + L110	30	E100M3NO8, E100M4NO8, E100M5NO8, E100M6NO8, E100M8NO8, E100M10NO8, E100M12NO8, E100M14NO8, E100M16NO8, E100M18NO8, E100M20NO8	F100M3, F100M4, F100M5, F100M6, F100M8, F100M10, F100M12, F100M14, F100M16, F100M18, F100M20	L112NO1.1/2, L112NO4	L1102A, L1102B, L1103, L1104, L1105, L1106	L12030
HS-2M	E500 + F300 + L112 + L110	23	E500M2NO1, E500M2NO3, E500M2.5NO1, E500M2.5NO3, E500M3NO1, E500M3NO3, E500M3.5NO1, E500M3.5NO3, E500M4NO1, E500M4NO3, E500M5NO1, E500M5NO3, E500M6NO1, E500M6NO3	F300M2X13/16, F300M2.5X13/16, F300M3X13/16, F300M3.5X13/16, F300M4X13/16, F300M5X13/16, F300M6X13/16	L112BT1	L11013/16	L1202M
HS-4M	E500 + F300 + L112 + L110	32	E500M5NO1, E500M5NO3, E500M6NO1, E500M6NO3, E500M7NO1, E500M7NO3, E500M8NO1, E500M8NO3, E500M9NO1, E500M9NO3, E500M10NO1, E500M10NO3, E500M11NO1, E500M11NO3, E500M12NO1, E500M12NO3	F300M5X13/16, F300M6X13/16, F300M7X13/16, F300M8X1.5/16, F300M9X1.5/16, F300M10X1.5/16, F300M11X1.5/16, F300M12X1.5/16, F300M5X13/16, F300M6X13/16, F300M7X13/16, F300M8X1.5/16, F300M9X1.5/16	L112BT2	L11013/16, L1101.5/16	L1204M

Set	A	B	M	F	L112	L110	L120
HS-8M	E500 + F300 + L112 + L110	17	E500M2NO1, E500M2NO3, E500M3NO1, E500M3NO3, E500M4NO1, E500M4NO3, E500M5NO1, E500M5NO3, E500M6NO1, E500M6NO3	F300M2X13/16, F300M3X13/16, F300M4X13/16, F300M5X13/16, F300M6X13/16	L112BT1	L11013/16	L1208M
HS-10M	E500 + F300 + L112 + L110	27	E500M3NO1, E500M3NO3, E500M4NO1, E500M4NO3, E500M5NO1, E500M5NO3, E500M6NO1, E500M6NO3, E500M7NO1, E500M7NO3, E500M8NO1, E500M8NO3, E500M9NO1, E500M9NO3, E500M10NO1, E500M10NO3	F300M3X13/16, F300M4X13/16, F300M5X13/16, F300M6X1, F300M7X1, F300M8X1, F300M9X1, F300M10X1	L112BT2	L11013/16, L1101INCH	L12010M
HS-12M	E500 + F300 + L112 + L110	35	E500M2NO1, E500M2NO3, E500M3NO1, E500M3NO3, E500M4NO1, E500M4NO3, E500M5NO1, E500M5NO3, E500M6NO1, E500M6NO3, E500M7NO1, E500M7NO3, E500M8NO1, E500M8NO3, E500M9NO1, E500M9NO3, E500M10NO1, E500M10NO3, E500M12NO1, E500M12NO3	F300M2X13/16, F300M3X13/16, F300M4X13/16, F300M5X13/16, F300M6X13/16, F300M7X13/16, F300M8X1, F300M9X1, F300M10X1, F300M12X1.5/16	L112BT1, L112BT2	L11013/16, L1101INCH, L1101.5/16	L12012M
HS-14M	E500 + F300 + L112 + L110	34	E500M6NO1, E500M6NO3, E500M7NO1, E500M7NO3, E500M8NO1, E500M8NO3, E500M9NO1, E500M9NO3, E500M10NO1, E500M10NO3, E500M12NO1, E500M12NO3, E500M14NO1, E500M14NO3, E500M16NO1, E500M16NO3, E500M18NO1, E500M18NO3, E500M20NO1, E500M20NO3	F300M6X1, F300M7X1, F300M8X1, F300M9X1, F300M10X1, F300M12X1.5/16, F300M14X1.5/16, F300M16X1.1/2, F300M18X1.1/2, F300M20X1.1/2	L112NO3	L1101INCH, L1101.5/16, L1101.1/2	L12014M
HS-30UNC	E515 + F320 + L112 + L110	18	E5151/2NO1, E5151/2NO3, E5151/4NO1, E5151/4NO3, E5155/16NO1, E5155/16NO3, E5153/8NO1, E5153/8NO3, E5157/16NO1, E5157/16NO3	F3201/4X1, F3205/16X1, F3207/16X1.5/16, F3203/8X1, F3201/2X1.5/16	L112BT2	L1101INCH, L1101.5/16	L12030UNC
HS-32UNC	E515 + F320 + L112 + L110	27	E5151/2NO1, E5151/2NO3, E5151/4NO1, E5151/4NO3, E5155/16NO1, E5155/16NO3, E5153/8NO1, E5153/8NO3, E5157/16NO1, E5157/16NO3, E5155/8NO1, E5155/8NO3, E5153/4NO1, E5153/4NO3	F3201/4X1, F3205/16X1, F3207/16X1.5/16, F3203/8X1, F3207/16X1.1/2, F3201/2X1.5/16, F3201/2X1.1/2, F3205/8X1.1/2, F3203/4X1.1/2	L112BT2, L112NO3	L1101INCH, L1101.1/2	L12032UNC

Set	A	B	M	F	L112	L110	L120
HS-24UNF	E524 + F330 + L112 + L110	18	E5241/2NO1, E5241/2NO3, E5241/4NO1, E5241/4NO3, E5245/16NO1, E5245/16NO3, E5243/8NO1, E5243/8NO3, E5247/16NO1, E5247/16NO3	F3301/4X1, F3305/16X1, F3307/16X1.5/16, F3303/8X1, F3301/2X1.5/16	L112BT2	L1101INCH, L1101.5/16	L12024UNF
HS-26UNF	E524 + F330 + L112 + L110	25	E5241/2NO1, E5241/2NO3, E5241/4NO1, E5241/4NO3, E5245/16NO1, E5245/16NO3, E5243/8NO1, E5243/8NO3, E5247/16NO1, E5247/16NO3, E5245/8NO1, E5245/8NO3, E5243/4NO1, E5243/4NO3	F3301/4X1, F3305/16X1, F3303/8X1, F3307/16X1.1/2, F3301/2X1.1/2, F3305/8X1.1/2, F3303/4X1.1/2	L112BT2, L112NO3	L1101INCH, L1101.1/2	L12026UNF

L110

- Girafiliere
- Schneideisenhalter
- Snijraam
- Porte filières



Nr.	Ø x H	L110
1"	16 x 5	L1101
2a	20 x 5	L1102A
2b	20 x 7	L1102B
3	25 x 9	L1103
4"	30 x 11	L1104
5	38 x 14	L1105
5f	38 x 10	L1105F
6	45 x 18	L1106
6f	45 x 14	L1106F
7	55 x 22	L1107
7f	55 x 16	L1107F
8	65 x 25	L1108
8f	65 x 18	L1108F
9	75 x 30	L1109
9f	75 x 20	L1109F
10	90 x 36	L11010
10f	90 x 22	L11010F
	13/16 x 1/4	L11013/16
	1 x 3/8	L1101INCH
	1.5/16 x 7/16	L1101.5/16
	1.1/2 x 1/2	L1101.1/2
	2 x 5/8	L1102INCH
	2.1/4 x 11/16	L1102.1/4
	3 x 7/8	L1103INCH
	4 x 1	L1104INCH

L112

- Giramaschio
- Verstellbares Windeisen
- Wringijzer, verstelbaar
- Tourne à gauche

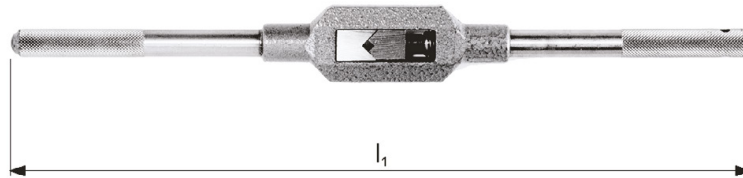

Nr.	l_1 mm	\square a mm	\square a Inch	Tap Range (M)	Tap Range (Inch)	L112
BT1	105	1.0 - 6.5	0.0394 - 0.2559	M1 - M8	No. 0 - 5/16	L112BT1
BT2	162	1.0 - 10.0	0.0394 - 0.3937	M1 - M14	No. 0 - 5/8	L112BT2
0	130	2.0 - 5.0	0.0787 - 0.1969	M1 - M5	No. 0 - 1/4	L112NO0
1.1/2	205	2.1 - 8.0	0.0827 - 0.3150	M2.2 - M12	No. 0 - 1/2	L112NO1.1/2
3	380	4.9 - 12.0	0.1929 - 0.4724	M5 - M20	5/16 - 3/4	L112NO3
4	500	5.5 - 16.0	0.2165 - 0.6299	M7 - M30	5/16 - 1"	L112NO4
6	1000	11.0 - 24.0	0.4331 - 0.9449	M18 - M42	3/4 - 1.1/2	L112NO6
7	1250	16.0 - 32.0	0.6299 - 1.2598	M27 - M48	1.1/8 - 2"	L112NO7

351 - 372



F100	355
F108	355
F110	356
F120	357
F130	358
F140	359
F150	360
F170	361
F180	362
F190	363
F201	355
F202	369
F272	372
F300	364
F302	370
F310	365
F312	371
F320	366
F330	367
F370	368

Forma Filetto	Gewindeform	Draadsoort	Forme de filet
Normativa	Standard	Norm	Standard
Tolleranza	Toleranz	Tolerantie	Tolérance
Lunghezza Imbocco	Anschnitt	Aansnijding	Chanfrein
Materiale	Material	Materiaal	Matière
Senso di rotazione	Schneidrichtung	Snijrichting	Direction
Trattamento superficiale	Oberfläche	Oppervlaktebehandeling	Revêtement
<ul style="list-style-type: none"> ■ Raccomandato ● Accettabile <p>Esempio 10 = Velocità periferica in m/min +/- 10%</p>	<p>Sehr gut für die Anwendung</p> <p>Gut für die Anwendung</p> <p>Beispiel 10 = Schnittgeschwindigkeit (m/min) +/- 10 %</p>	<p>Uitstekend voor deze toepassing</p> <p>Acceptabel voor deze toepassing</p> <p>Voorbeeld 10= snijsnelheid in m/min +/-10%</p>	<p>Excellent pour les applications</p> <p>Acceptable pour les applications</p> <p>Exemple 10 = Vitesse périphérique en mètres/minute +/- 10%</p>
Codice prodotto	Produktbezeichnung	Productcode	Codes
Gamma diametri	Durchmesserbereich	Diameterreeks	Gamme

AMG	Italiano	Deutsch	Nederlands	Français
1.1	Acciaio dolce magnetico	Magnetweicheisen	Automatenstaal, zachtstaal	Acier doux magnétique
1.2	Acciaio da costruzione e da cementazione	Baustahl, Einsatzstahl	Constructiestaal, inzetstaal	Acier de construction, Acier de cémentation
1.3	Acciaio al carbonio	Kohlenstoffstahl	Koolstofstaal	Acier au carbone ordinaire
1.4	Acciaio legato	Legierter Stahl	Gelegeerd staal	Acier allié
1.5	Acciaio legato / Acciaio bonificato e temprato	Legierter und vergüteter Stahl	Gelegeerd en veredeld staal	Acier allié/ Acier trempé et revenu
1.6	Acciaio legato / Acciaio bonificato e temprato	Legierter und vergüteter Stahl	Hooggelegeerd veredeld staal	Acier allié/ Acier trempé et revenu
1.7	Acciaio legato/temprato	Legierter gehärteter Stahl	Gelegeerd en gehard staal	Acier allié trempé
1.8	Acciaio legato/temprato	Legierter gehärteter Stahl	Gelegeerd en gehard staal	Acier allié trempé
2.1	Acciaio inossidabile/automatico	Rostfreier Stahl, geschwefelt	Roestvast automatenstaal	Acier inoxydable de décolletage
2.2	Austenitico	Austenitisch	Austenitisch	Austénitique
2.3	Ferritico+Austenitico, Martensitico	Ferritisch+Austenitisch, Martensitisch	Ferritisch+Austenitisch, Martensitisch	Ferritique + Austénitique, Martensitique
2.4	Acciai inossidabili con indurimento da precipitazione	Vergüteter rostfreier Stahl	Precipitatiehardend roestvast staal	Acier inoxydable Trempé
3.1	Ghisa con grafite lamellare	Grauguss	Gietijzer Lamellair	Graphite lamellaire
3.2	Ghisa con grafite lamellare	Vergüteter Grauguss	Gietijzer Lamellair	Graphite lamellaire
3.3	Ghisa malleabile con grafite sferoidale	Kugelgraphitguss, Temperguss	Nodulair gietijzer / Smeedbaar gietijzer	Graphite nodulaire/ Fonte malléable
3.4	Ghisa malleabile con grafite sferoidale	Kugelgraphitguss, Temperguss	Nodulair gietijzer / Smeedbaar gietijzer	Graphite nodulaire/ Fonte malléable
4.1	Titanio non legato	Reintitan	Titaan, ongelegeerd	Titane, non-allié
4.2	Leghe di titanio	Titan-Legierungen	Titaan, gelegeerd	Titane, allié
4.3	Leghe di titanio	Titan-Legierungen	Titaan, gelegeerd	Titane, allié
5.1	Nichel non legato	Reinnickel	Nikkel, ongelegeerd	Nickel, non-allié
5.2	Leghe di nichel	Nickel-Legierungen	Nikkel, gelegeerd	Nickel, allié
5.3	Leghe di nichel	Nickel-Legierungen	Nikkel, gelegeerd	Nickel, allié
6.1	6.1 Rame	Kupfer	Koper	Cuivre
6.2	β-Ottone, Bronzo	Kurzspanendes Messing, Bronze	β-Messing, brons	β-Laiton, Bronze
6.3	α-Ottone	Langspanendes Messing	α-Messing	α-Laiton
6.4	Bronzo ad alta resistenza	Cu-Al-Fe-Legierung, (Ampco)	Extra-sterk brons	Bronze, haute résistance
7.1	Al, Mg, non legato	Al, Mg, unlegiert	Al, Mg, ongelegeerd	Al, Mg, non-allié
7.2	Leghe di Al, Si < 0.5%	Al legiert, Si<0.5 %	Al gelegeerd, Si < 0.5%	Al allié, Si < 0.5%
7.3	Leghe di Al, Si > 0.5% < 10%	Al legiert, Si>0.5 %<10 %	Al gelegeerd, Si > 0.5% < 10%	Al allié, Si > 0.5% < 10%
7.4	Leghe di Al, Si > 10% Rinforzate Whisker Leghe di Al, Leghe di Mg	Al legiert, Si>10 % Whisker verstärkte Al-Legierung, Mg-Legierung	Al gelegeerd, Si>10% whisker versterkt Al-legierungen, Mg-legierungen	Al allié, Si>10% Alliages d'Al ou Mg, céramique renforcée
8.1	Materiali termoplastici	Thermoplaste	Thermoplasten	Thermoplastiques
8.2	Materiali plastici termoindurenti	Duroplaste	Duraplasten	Plastiques thermodurcissables
8.3	Materiali plastici rinforzati	Faserverstärkte Kunststoffe	Versterkte kunststofmaterialen	Plastiques renforcés
9.1	Cermets (materiali metallo-ceramic)	Cermets (Metallkeramik)	Cermets (metal-ceramics)	Cermets (céramiques métalliques)
10.1	Grafite standard	Graphit	Standaard Grafiet	Graphite standard

M	M	M	MF	UNC	UNF	BSW	BSF	G	NPT	PG
ISO 2568	ISO 2568	ISO 2568	ISO 2568	ISO 2568	ISO 2568	ISO 2568	ISO 2568	ISO 2568	ISO 2568	ISO 2568
6g	6g	6g	6g	2A	2A	Medium	Medium	Class A	Normal	Normal
1.75XP	1.75XP	2.25XP	1.75XP	1.75XP	1.75XP	1.75XP	1.75XP	1.75XP	1.75XP	1.75XP
HSS	HSS	HSS-E	HSS	HSS	HSS	HSS	HSS	HSS	HSS	HSS

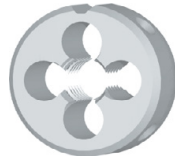

F100	F201	F108	F110	F120	F130	F140	F150	F170	F180	F190
M2 - M42	M3 - M20	M2 - M20	M4 - M40	No.8 - 1"	No.10 - 1"	1/8 - 1"	3/16 - 1/2	1/8 - 2"	1/8 - 1"	No.7 - No.36

AMG	355	355	355	356	357	358	359	360	361	362	363	ISO
1.1	■8	■8	●8	■8	■8	■8	■8	■8	■8	■8	■8	P 1
1.2	■7	■7	●7	■7	■7	■7	■7	■7	■7	■7	■7	P 1
1.3	■6	■6	■6	■6	■6	■6	■6	■6	■6	■6	■6	P 2
1.4	●5	●5	■5	●5	●5	●5	●5	●5	●5	●5	●5	P 3
1.5			●4									P 4
1.6												H 1
1.7												H 3
1.8												H 4
2.1	●4	●4	■4	●4	●4	●4	●4	●4	●4	●4	●4	M 1
2.2	●2	●2	■2	●2	●2	●2	●2	●2	●2	●2	●2	M 3
2.3			●1									M 2
2.4												S 2
3.1	■8	■8	■8	■8	■8	■8	■8	■8	■8	■8	■8	K 1
3.2	■7	■7	■7	■7	■7	■7	■7	■7	■7	■7	■7	K 2
3.3	■6	■6	■6	■6	■6	■6	■6	■6	■6	■6	■6	K 3
3.4	●5	●5	●5	●5	●5	●5	●5	●5	●5	●5	●5	K 4
4.1			●2									S 1
4.2												S 2
4.3	●2	●2	●2	●2	●2	●2	●2	●2	●2	●2	●2	S 3
5.1	●9	●9	●9	●9	●9	●9	●9	●9	●9	●9	●9	S 1
5.2	●2	●2	●2	●2	●2	●2	●2	●2	●2	●2	●2	S 2
5.3	●2	●2	●2	●2	●2	●2	●2	●2	●2	●2	●2	S 3
6.1	●9	●9	●9	●9	●9	●9	●9	●9	●9	●9	●9	N 3
6.2	●8	●8	●8	●8	●8	●8	●8	●8	●8	●8	●8	N 4
6.3	●7	●7	●7	●7	●7	●7	●7	●7	●7	●7	●7	N 3
6.4			●2									N 4
7.1	■10	■10	■10	■10	■10	■10	■10	■10	■10	■10	■10	N 1
7.2	■15	■15	■15	■15	■15	■15	■15	■15	■15	■15	■15	N 1
7.3	■15	■15	■15	■15	■15	■15	■15	■15	■15	■15	■15	N 1
7.4	●10	●10	●10	●10	●10	●10	●10	●10	●10	●10	●10	N 2
8.1	●15	●15	●15	●15	●15	●15	●15	●15	●15	●15	●15	O
8.2	●10	●10	●10	●10	●10	●10	●10	●10	●10	●10	●10	O
8.3	●5	●5	●5	●5	●5	●5	●5	●5	●5	●5	●5	O
9.1												H
10.1												O

M	MF	UNC	UNF	G	M	M	MF	G
BS 1127: 1950	BS 1127: 1950	BS 1127: 1950	BS 1127: 1950	BS 1127: 1950	DIN 382	BS 1127: 1950	BS 1127: 1950	DIN 382
1.75XP	1.75XP	1.75XP	1.75XP	1.75XP	6g	6g	6g	Class A
HSS	HSS	HSS	HSS	HSS	HSS	HSS	HSS	HSS



	F300	F310	F320	F330	F370	F202	F302	F312	F272	
	M2 - M36	M3 - M30	No.4 - 1.1/4	No.4 - 1.1/2	1/8 - 1.1/2	M3 - M36	M3 - M36	M8 - M24	1/8 - 1.1/2	
AMG	364	365	366	367	368	369	370	371	372	ISO
1.1	■8	■8	■8	■8	■8	■8	■8	■8	■8	P 1
1.2	■7	■7	■7	■7	■7	■7	■7	■7	■7	P 1
1.3	■6	■6	■6	■6	■6	■6	■6	■6	■6	P 2
1.4	●5	●5	●5	●5	●5	●5	●5	●5	●5	P 3
1.5										P 4
1.6										H 1
1.7										H 3
1.8										H 4
2.1	●4	●4	●4	●4	●4	●4	●4	●4	●4	M 1
2.2	●2	●2	●2	●2	●2	●2	●2	●2	●2	M 3
2.3										M 2
2.4										S 2
3.1	■8	■8	■8	■8	■8	■8	■8	■8	■8	K 1
3.2	■7	■7	■7	■7	■7	■7	■7	■7	■7	K 2
3.3	■6	■6	■6	■6	■6	■6	■6	■6	■6	K 3
3.4	●5	●5	●5	●5	●5	●5	●5	●5	●5	K 4
4.1										S 1
4.2										S 2
4.3	●2	●2	●2	●2	●2	●2	●2	●2	●2	S 3
5.1	●9	●9	●9	●9	●9	●9	●9	●9	●9	S 1
5.2	●2	●2	●2	●2	●2	●2	●2	●2	●2	S 2
5.3	●2	●2	●2	●2	●2	●2	●2	●2	●2	S 3
6.1	●9	●9	●9	●9	●9	●9	●9	●9	●9	N 3
6.2	●8	●8	●8	●8	●8	●8	●8	●8	●8	N 4
6.3	●7	●7	●7	●7	●7	●7	●7	●7	●7	N 3
6.4										N 4
7.1	■10	■10	■10	■10	■10	■10	■10	■10	■10	N 1
7.2	■15	■15	■15	■15	■15	■15	■15	■15	■15	N 1
7.3	■15	■15	■15	■15	■15	■15	■15	■15	■15	N 1
7.4	●10	●10	●10	●10	●10	●10	●10	●10	●10	N 2
8.1	●15	●15	●15	●15	●15	●15	●15	●15	●15	O
8.2	●10	●10	●10	●10	●10	●10	●10	●10	●10	O
8.3	●5	●5	●5	●5	●5	●5	●5	●5	●5	O
9.1										H
10.1										O

- F100** • M Filiera con imbocco corretto
F201 • M Schneideisen, Schälanschnitt, geläpft
F108 • M Snijsplaat met schilaansnijding, geläpft
 • M Filières

F100; F201	▪	1.1	1.2	1.3	3.1	3.2	3.3	7.1	7.2	7.3									
	•	1.4	2.1	2.2	3.4	4.3	5.1	5.2	5.3	6.1	6.2	6.3	7.4	8.1	8.2	8.3			
F108	▪	1.3	1.4	2.1	2.2	3.1	3.2	3.3	7.1	7.2	7.3								
	•	1.1	1.2	1.5	2.3	3.4	4.1	4.3	5.1	5.2	5.3	6.1	6.2	6.3	6.4	7.4	8.1	8.2	8.3

F100	M	ISO 2568	6g	1.75XP	HSS			
F201	M	ISO 2568	6g	1.75XP	HSS			
F108	M	ISO 2568	6g	2.25XP	HSS-E			

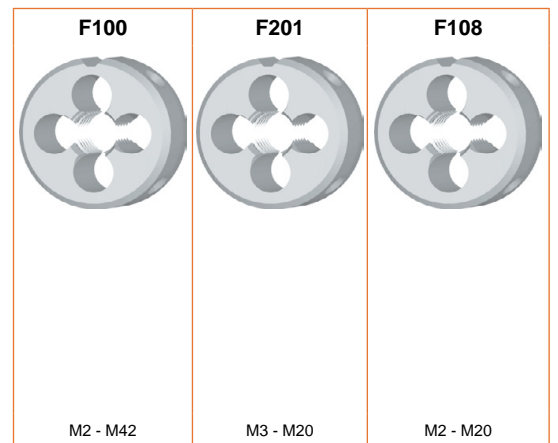
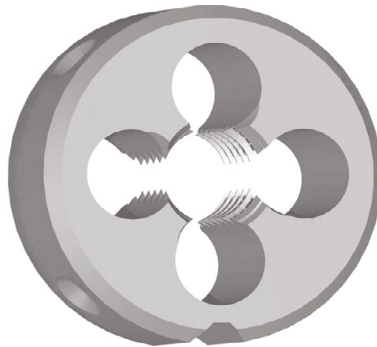
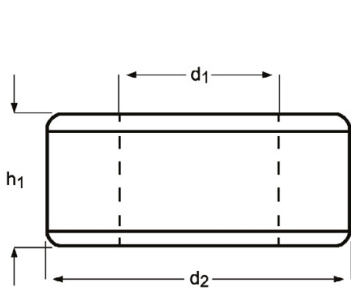

M	P mm	d ₂ Ø mm	h ₁ mm	F100	F201	F108
2	0.40	16	5	F100M2 ¹⁾		F108M2 ¹⁾
2.5	0.45	16	5	F100M2.5 ¹⁾		F108M2.5 ¹⁾
2.6	0.45	16	5	F100M2.6 ¹⁾		
3	0.50	20	5	F100M3	F201M3	F108M3
3.5	0.60	20	5	F100M3.5		
4	0.70	20	5	F100M4	F201M4	F108M4
4.5	0.75	20	7	F100M4.5		
5	0.80	20	7	F100M5	F201M5	F108M5
6	1.00	20	7	F100M6	F201M6	F108M6
7	1.00	25	9	F100M7		
8	1.25	25	9	F100M8	F201M8	F108M8
9	1.25	25	9	F100M9		
10	1.50	30	11	F100M10	F201M10	F108M10
11	1.50	30	11	F100M11		
12	1.75	38	14	F100M12	F201M12	F108M12
14	2.00	38	14	F100M14	F201M14	F108M14
16	2.00	45	18	F100M16	F201M16	F108M16
18	2.50	45	18	F100M18	F201M18	F108M18
20	2.50	45	18	F100M20	F201M20	F108M20
22	2.50	55	22	F100M22		
24	3.00	55	22	F100M24		
27	3.00	65	25	F100M27		
30	3.50	65	25	F100M30		
33	3.50	65	25	F100M33		
36	4.00	65	25	F100M36		
39	4.00	75	30	F100M39		
42	4.50	75	30	F100M42		

¹⁾ senza imbocco corretto / ohne Schälanschnitt / Zonder schilaansnijding / Sans entrée gun

- MF Filiera con imbocco corretto
- MF Schneideisen, Schälanschnitt, geläpft
- MF Snijplaat met schilaansnijding
- MF Filières

F110

F110	▪	1.1	1.2	1.3	3.1	3.2	3.3	7.1	7.2	7.3						
	•	1.4	2.1	2.2	3.4	4.3	5.1	5.2	5.3	6.1	6.2	6.3	7.4	8.1	8.2	8.3

F110

MF

ISO
2568

6g

1.75XP

HSS

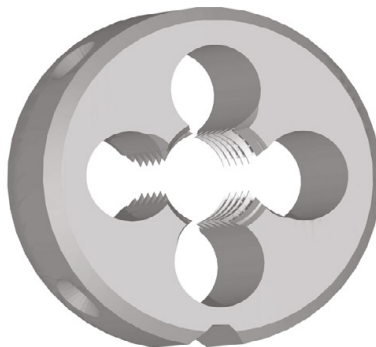
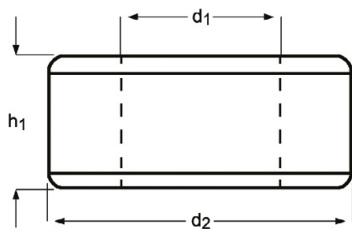

F110



M4 - M40

MF	P mm	d ₂ Ø mm	h ₁ mm	F110
4	0.50	20	5	F110M4X.5
5	0.50	20	5	F110M5X.5
6	0.75	20	7	F110M6X.75
7	0.75	25	9	F110M7X.75
8	0.75	25	9	F110M8X.75
8	1.00	25	9	F110M8X1.0
9	1.00	25	9	F110M9X1.0
10	0.75	30	11	F110M10X.75
10	1.00	30	11	F110M10X1.0
10	1.25	30	11	F110M10X1.25
11	1.00	30	11	F110M11X1.0
12	1.00	38	10	F110M12X1.0
12	1.25	38	10	F110M12X1.25
12	1.50	38	10	F110M12X1.5
13	1.00	38	10	F110M13X1.0
14	1.00	38	10	F110M14X1.0
14	1.25	38	10	F110M14X1.25
14	1.50	38	10	F110M14X1.5
15	1.00	38	10	F110M15X1.0
15	1.50	38	10	F110M15X1.5
16	1.00	45	14	F110M16X1.0
16	1.50	45	14	F110M16X1.5
18	1.00	45	14	F110M18X1.0
18	1.50	45	14	F110M18X1.5
20	1.00	45	14	F110M20X1.0
20	1.50	45	14	F110M20X1.5
22	1.00	55	16	F110M22X1.0
22	1.50	55	16	F110M22X1.5
24	1.00	55	16	F110M24X1.0
24	1.50	55	16	F110M24X1.5
24	2.00	55	16	F110M24X2.0
25	1.50	55	16	F110M25X1.5
26	1.50	55	16	F110M26X1.5
27	1.50	65	18	F110M27X1.5
27	2.00	65	18	F110M27X2.0
28	1.50	65	18	F110M28X1.5
30	1.50	65	18	F110M30X1.5
32	1.50	65	18	F110M32X1.5
35	1.50	65	18	F110M35X1.5
36	1.50	65	18	F110M36X1.5
40	1.50	75	20	F110M40X1.5

F120

- UNC Filiera con imbocco corretto
- UNC Schneideisen, Schälanschnitt, geläpft
- UNC Snijplaat met schilaansnijding
- UNC Filières

F120	▪	1.1	1.2	1.3	3.1	3.2	3.3	7.1	7.2	7.3						
	•	1.4	2.1	2.2	3.4	4.3	5.1	5.2	5.3	6.1	6.2	6.3	7.4	8.1	8.2	8.3

F120 **UNC** **ISO 2568** **2A** **1.75XP** **HSS**

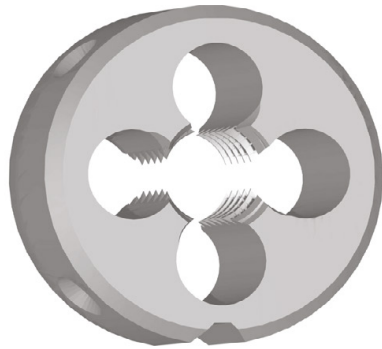
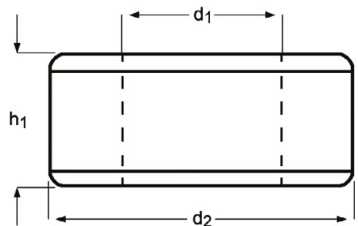

UNC	TPI	d_1 nom mm	d_2 Ø mm	h_1 mm	F120
8	32	4.17	20	7	F1208-32
10	24	4.83	20	7	F12010-24
1/4	20	6.35	20	7	F1201/4
5/16	18	7.94	25	9	F1205/16
3/8	16	9.53	30	11	F1203/8
7/16	14	11.11	30	11	F1207/16
1/2	13	12.70	38	14	F1201/2
9/16	12	14.29	38	14	F1209/16
5/8	11	15.88	45	18	F1205/8
3/4	10	19.05	45	18	F1203/4
7/8	9	22.23	55	22	F1207/8
1"	8	25.40	55	22	F1201

- F130**
- UNF Filiera con imbocco corretto
 - UNF Schneideisen, Schälanschnitt, geläppt
 - UNF Snijplaat met schilaansnijding
 - UNF Filières

F130	▪	1.1	1.2	1.3	3.1	3.2	3.3	7.1	7.2	7.3								
	•	1.4	2.1	2.2	3.4	4.3	5.1	5.2	5.3	6.1	6.2	6.3	7.4	8.1	8.2	8.3		

F130 **UNF** **ISO 2568** **2A** **1.75XP** **HSS**  

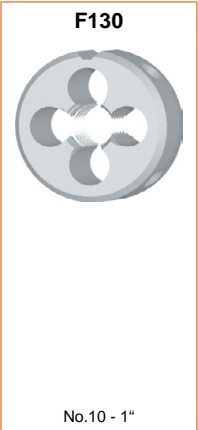
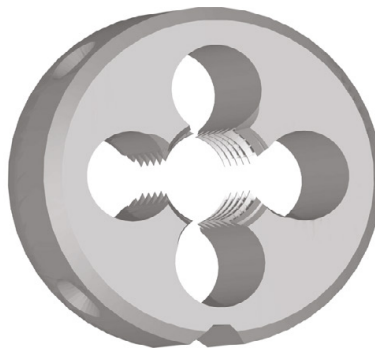
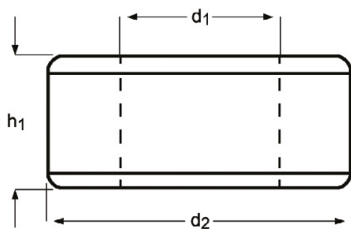

UNF	TPI	d_1 nom mm	d_2 \emptyset mm	h_1 mm	F130
10	32	4.83	20	7	F13010-32
1/4	28	6.35	20	7	F1301/4
5/16	24	7.94	25	9	F1305/16
3/8	24	9.53	30	11	F1303/8
7/16	20	11.11	30	11	F1307/16
1/2	20	12.70	38	10	F1301/2
9/16	18	14.29	38	10	F1309/16
5/8	18	15.88	45	14	F1305/8
3/4	16	19.05	45	14	F1303/4
7/8	14	22.23	55	16	F1307/8
1"	12	25.40	55	16	F1301

- F140**
- BSW Filiera con imbocco corretto
 - BSW Schneideisen, Schälanschnitt, geläpft
 - BSW Snijplaat met schilaansnijding
 - BSW Filières

F140	▪	1.1	1.2	1.3	3.1	3.2	3.3	7.1	7.2	7.3								
	•	1.4	2.1	2.2	3.4	4.3	5.1	5.2	5.3	6.1	6.2	6.3	7.4	8.1	8.2	8.3		

F140 **BSW** **ISO 2568** Medium **1.75XP** **HSS**  

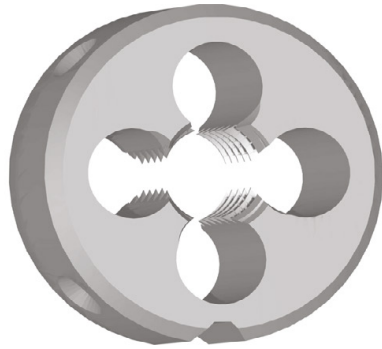
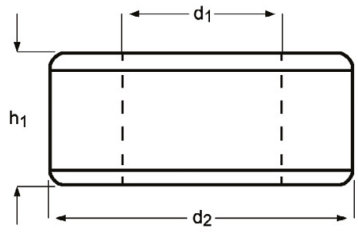

BSW	TPI	d_1 nom mm	d_2 Ø mm	h_1 mm	F140
1/8	40	3.17	20	5	F1401/8
3/16	24	4.76	20	7	F1403/16
1/4	20	6.35	20	7	F1401/4
5/16	18	7.94	25	9	F1405/16
3/8	16	9.53	30	11	F1403/8
7/16	14	11.11	30	11	F1407/16
1/2	12	12.70	38	14	F1401/2
5/8	11	15.88	45	18	F1405/8
3/4	10	19.05	45	18	F1403/4
7/8	9	22.23	55	22	F1407/8
1"	8	25.40	55	22	F1401

- F150**
- BSF Filiera con imbocco corretto
 - BSF Schneideisen, Schälanschnitt, geläpft
 - BSF Snijplaat met schilaansnijding
 - BSF Filières

F150	▪	1.1	1.2	1.3	3.1	3.2	3.3	7.1	7.2	7.3						
	•	1.4	2.1	2.2	3.4	4.3	5.1	5.2	5.3	6.1	6.2	6.3	7.4	8.1	8.2	8.3

F150 **BSF** **ISO 2568** Medium **1.75XP** **HSS**  

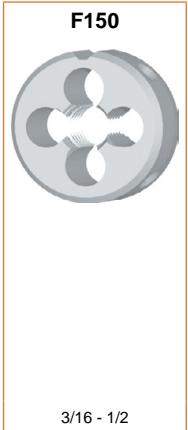
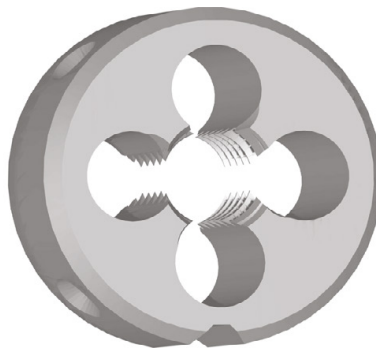
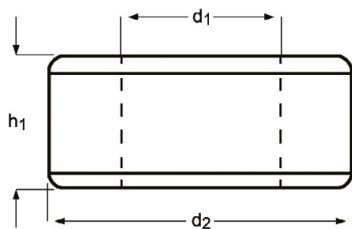

BSF	TPI	d_1 nom mm	d_2 Ø mm	h_1 mm	F150
3/16	32	4.76	20	7	F1503/16
1/4	26	6.35	20	7	F1501/4
5/16	22	7.94	25	9	F1505/16
3/8	20	9.53	30	11	F1503/8
7/16	18	11.11	30	11	F1507/16
1/2	16	12.70	38	10	F1501/2

- F170**
- G(BSP) Filiera con imbocco corretto
 - G(BSP) Schneideisen, Schälanschnitt, geläpft
 - G(BSP) Snijplaten met schilaansnijding
 - G(BSP) Filières

F170	▪	1.1	1.2	1.3	3.1	3.2	3.3	7.1	7.2	7.3						
	•	1.4	2.1	2.2	3.4	4.3	5.1	5.2	5.3	6.1	6.2	6.3	7.4	8.1	8.2	8.3

F170

G

ISO
2568

Class
A

1.75XP

HSS

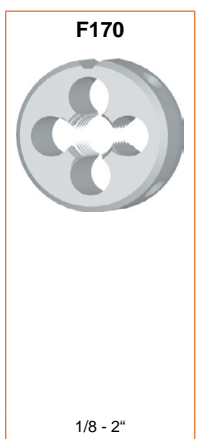
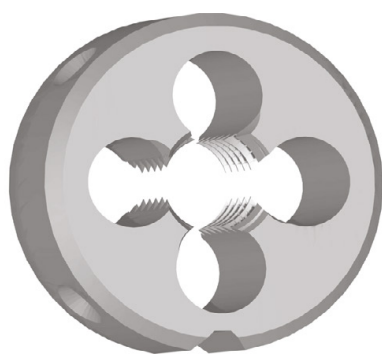
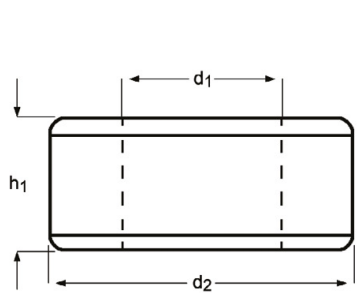

G(BSP)	TPI	d_1 nom mm	d_2 Ø mm	h_1 mm	F170
1/8	28	9.73	30	11	F1701/8
1/4	19	13.16	38	10	F1701/4
3/8	19	16.66	45	14	F1703/8
1/2	14	20.96	45	14	F1701/2
5/8	14	22.91	55	16	F1705/8
3/4	14	26.44	55	16	F1703/4
7/8	14	30.20	65	18	F1707/8
1"	11	33.25	65	18	F1701
1.1/8	11	37.89	75	20	F1701.1/8
1.1/4	11	41.91	75	20	F1701.1/4
1.1/2	11	47.80	90	22	F1701.1/2
2"	11	59.61	105	22	F1702

- F180**
- NPT Filiera con imbocco corretto
 - NPT Schneideisen, Schälanschnitt, geläppt
 - NPT Snijplaat met schilaansnijding
 - NPT Filières

F180	▪	1.1	1.2	1.3	3.1	3.2	3.3	7.1	7.2	7.3						
	•	1.4	2.1	2.2	3.4	4.3	5.1	5.2	5.3	6.1	6.2	6.3	7.4	8.1	8.2	8.3

F180

NPT ISO 2568 Normal 1.75XP HSS

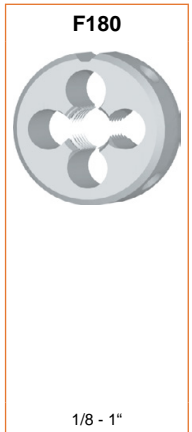
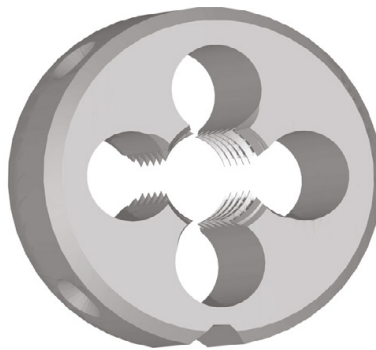
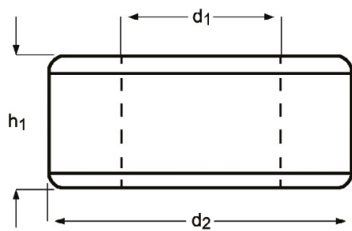

NPT	TPI	d_1 nom mm	d_2 Ø mm	h_1 mm	F180
1/8	27	9.49	30	11	F1801/8
1/4	18	12.49	38	14	F1801/4
3/8	18	15.93	45	14	F1803/8
1/2	14	19.77	45	18	F1801/2
3/4	14	25.12	55	22	F1803/4
1"	11.5	31.46	65	25	F1801

F190

- PG Filiera con imbocco corretto
- PG Schneideisen, Schälanschnitt, geläpft
- PG Snijplaat met schilaansnijding
- PG Filières

F190	▪	1.1	1.2	1.3	3.1	3.2	3.3	7.1	7.2	7.3									
	•	1.4	2.1	2.2	3.4	4.3	5.1	5.2	5.3	6.1	6.2	6.3	7.4	8.1	8.2	8.3			

F190 **PG** **ISO 2568** Normal **1.75XP** **HSS**  

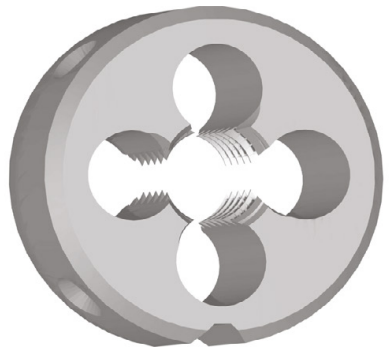
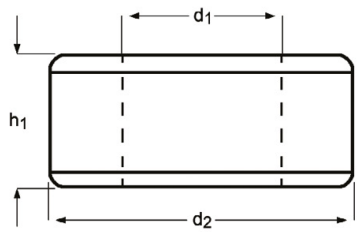

PG	TPI	d_1 nom mm	d_2 \emptyset mm	h_1 mm	F190
7	20	12.5	38	10	F190PG7
9	18	15.2	38	10	F190PG9
11	18	18.6	45	14	F190PG11
13.5	18	20.4	45	14	F190PG13.5
16	18	22.5	55	16	F190PG16
21	16	28.3	65	18	F190PG21
29	16	37.0	65	18	F190PG29
36	16	47.0	90	22	F190PG36

- F300**
- M Filiere regolabili
 - M Schneideisen - geschlitzt, verstellbar
 - M Verstelbare snijplaat
 - M Filières extensibles

F300	▪	1.1	1.2	1.3	3.1	3.2	3.3	7.1	7.2	7.3						
	•	1.4	2.1	2.2	3.4	4.3	5.1	5.2	5.3	6.1	6.2	6.3	7.4	8.1	8.2	8.3

F300 **M** **BS 1127: 1950** **1.75XP** **HSS**   

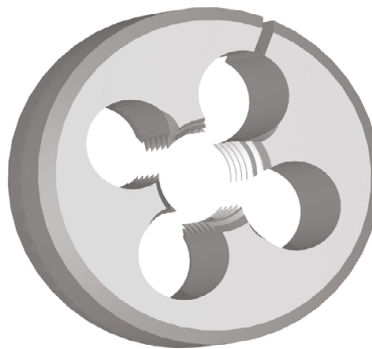
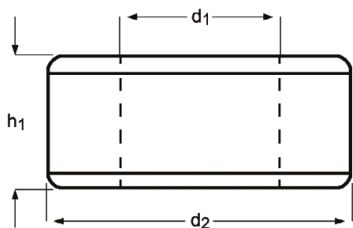

M	P mm	d ₂ Ø Inch	h ₁ Inch	F300
2	0.40	13/16	1/4	F300M2X13/16
2.5	0.45	13/16	1/4	F300M2.5X13/16
3	0.50	13/16	1/4	F300M3X13/16
3.5	0.60	13/16	1/4	F300M3.5X13/16
4	0.70	13/16	1/4	F300M4X13/16
5	0.80	13/16	1/4	F300M5X13/16
5	0.80	1"	3/8	F300M5X1
6	1.00	13/16	1/4	F300M6X13/16
6	1.00	1"	3/8	F300M6X1
6	1.00	1.5/16	7/16	F300M6X1.5/16
7	1.00	13/16	1/4	F300M7X13/16
7	1.00	1"	3/8	F300M7X1
8	1.25	1"	3/8	F300M8X1
8	1.25	1.5/16	7/16	F300M8X1.5/16
9	1.25	1"	3/8	F300M9X1
9	1.25	1.5/16	7/16	F300M9X1.5/16
10	1.50	1"	3/8	F300M10X1
10	1.50	1.5/16	7/16	F300M10X1.5/16
10	1.50	1.1/2	1/2	F300M10X1.1/2
11	1.50	1.5/16	7/16	F300M11X1.5/16
12	1.75	1.5/16	7/16	F300M12X1.5/16
12	1.75	1.1/2	1/2	F300M12X1.1/2
14	2.00	1.5/16	7/16	F300M14X1.5/16
14	2.00	1.1/2	1/2	F300M14X1.1/2
16	2.00	1.1/2	1/2	F300M16X1.1/2
16	2.00	2"	5/8	F300M16X2
18	2.50	1.1/2	1/2	F300M18X1.1/2
18	2.50	2"	5/8	F300M18X2
20	2.50	1.1/2	1/2	F300M20X1.1/2
20	2.50	2"	5/8	F300M20X2
22	2.50	2"	5/8	F300M22X2
24	3.00	2"	5/8	F300M24X2
27	3.00	3"	7/8	F300M27X3
30	3.50	3"	7/8	F300M30X3
36	4.00	3"	7/8	F300M36X3

- F310**
- MF Filiere regolabili
 - MF Schneideisen - geschlitzt, verstellbar
 - MF Verstelbare snijplaat
 - MF Filières extensibles

F310	▪	1.1	1.2	1.3	3.1	3.2	3.3	7.1	7.2	7.3						
	•	1.4	2.1	2.2	3.4	4.3	5.1	5.2	5.3	6.1	6.2	6.3	7.4	8.1	8.2	8.3

F310 MF BS 1127:1950 1.75XP HSS

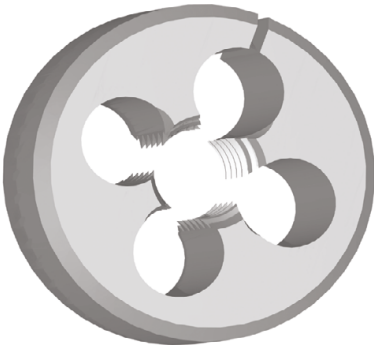
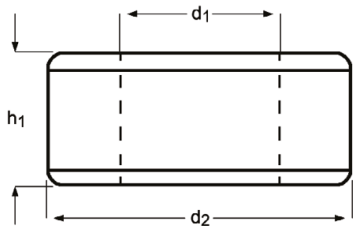

MF	P mm	d ₂ Ø Inch	h ₁ Inch	F310
3	0.35	13/16	1/4	F310M3X.35X13/16
4	0.50	13/16	1/4	F310M4X.5X13/16
4	0.75	13/16	1/4	F310M4X.75X13/16
5	0.50	13/16	1/4	F310M5X.5X13/16
5	0.90	13/16	1/4	F310M5X.9X13/16
6	0.75	13/16	1/4	F310M6X.75X13/16
8	0.75	1"	3/8	F310M8X.75X1
8	1.00	1"	3/8	F310M8X1.0X1
9	1.00	1"	3/8	F310M9X1.0X1
10	0.75	1"	3/8	F310M10X.75X1
10	1.00	1"	3/8	F310M10X1.0X1
10	1.25	1"	3/8	F310M10X1.25X1
10	1.25	1.5/16	7/16	F310M10X1.25X1.5/16
12	1.00	1.5/16	7/16	F310M12X1.0X1.5/16
12	1.25	1.5/16	7/16	F310M12X1.25X1.5/16
12	1.50	1.5/16	7/16	F310M12X1.5X1.5/16
14	1.25	1.5/16	7/16	F310M14X1.25X1.5/16
14	1.50	1.5/16	7/16	F310M14X1.5X1.5/16
16	1.00	1.1/2	1/2	F310M16X1.0X1.1/2
16	1.50	1.1/2	1/2	F310M16X1.5X1.1/2
18	1.50	1.1/2	1/2	F310M18X1.5X1.1/2
20	1.00	1.1/2	1/2	F310M20X1.0X1.1/2
20	1.50	2"	5/8	F310M20X1.5X2
20	2.00	1.1/2	1/2	F310M20X2.0X1.1/2
22	1.50	2"	5/8	F310M22X1.5X2
24	1.50	2"	5/8	F310M24X1.5X2
24	2.00	2"	5/8	F310M24X2.0X2
25	1.50	2"	5/8	F310M25X1.5X2
27	2.00	2.1/4	11/16	F310M27X2.0X2.1/4
30	2.00	2.1/4	11/16	F310M30X2.0X2.1/4

- UNC Filiere regolabili
- UNC Schneideisen - geschlitzt, verstellbar
- UNC Verstellbare snijplaat
- UNC Filières extensibles

F320

F320	▪	1.1	1.2	1.3	3.1	3.2	3.3	7.1	7.2	7.3								
	•	1.4	2.1	2.2	3.4	4.3	5.1	5.2	5.3	6.1	6.2	6.3	7.4	8.1	8.2	8.3		

F320 **UNC** **BS 1127: 1950** **1.75XP** **HSS**   

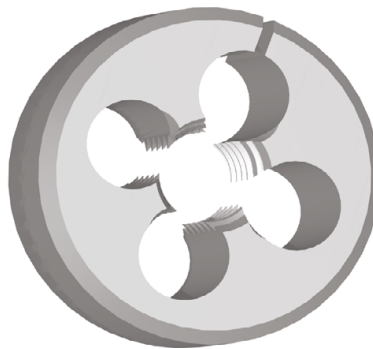
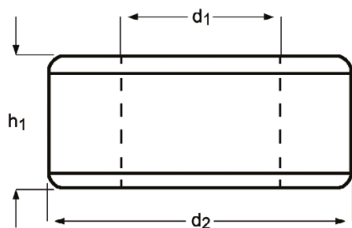

UNC	TPI	d_1 nom mm	d_2 Ø Inch	h_1 Inch	F320
4	40	2.85	13/16	1/4	F3204-40X13/16
5	40	3.18	13/16	1/4	F3205-40X13/16
6	32	3.51	13/16	1/4	F3206-32X13/16
8	32	4.17	13/16	1/4	F3208-32X13/16
8	32	4.17	1"	3/8	F3208-32X1
10	24	4.83	13/16	1/4	F32010-24X13/16
10	24	4.83	1"	3/8	F32010-24X1
12	24	5.49	13/16	1/4	F32012-24X13/16
1/4	20	6.35	13/16	1/4	F3201/4X13/16
1/4	20	6.35	1"	3/8	F3201/4X1
1/4	20	6.35	1.5/16	7/16	F3201/4X1.5/16
1/4	20	6.35	1.1/2	1/2	F3201/4X1.1/2
5/16	18	7.94	1"	3/8	F3205/16X1
5/16	18	7.94	1.1/2	1/2	F3205/16X1.1/2
3/8	16	9.53	1"	3/8	F3203/8X1
3/8	16	9.53	1.5/16	7/16	F3203/8X1.5/16
3/8	16	9.53	1.1/2	1/2	F3203/8X1.1/2
7/16	14	11.11	1.5/16	7/16	F3207/16X1.5/16
7/16	14	11.11	1.1/2	1/2	F3207/16X1.1/2
1/2	13	12.70	1.5/16	7/16	F3201/2X1.5/16
1/2	13	12.70	1.1/2	1/2	F3201/2X1.1/2
1/2	13	12.70	2"	5/8	F3201/2X2
9/16	12	14.29	1.1/2	1/2	F3209/16X1.1/2
5/8	11	15.88	1.1/2	1/2	F3205/8X1.1/2
5/8	11	15.88	2"	5/8	F3205/8X2
3/4	10	19.05	1.1/2	1/2	F3203/4X1.1/2
3/4	10	19.05	2"	5/8	F3203/4X2
7/8	9	22.23	2"	5/8	F3207/8X2
1"	8	25.40	2"	5/8	F3201X2
1.1/8	7	28.58	3"	7/8	F3201.1/8X3
1.1/4	7	31.75	3"	7/8	F3201.1/4X3

- F330**
- UNF Filiere regolabili
 - UNF Schneideisen - geschlitzt, verstellbar
 - UNF Verstelbare snijplaat
 - UNF Filières extensibles

F330	▪	1.1	1.2	1.3	3.1	3.2	3.3	7.1	7.2	7.3								
	•	1.4	2.1	2.2	3.4	4.3	5.1	5.2	5.3	6.1	6.2	6.3	7.4	8.1	8.2	8.3		

F330 UNF BS 1127: 1950 1.75XP HSS 339

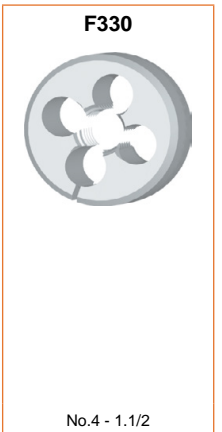
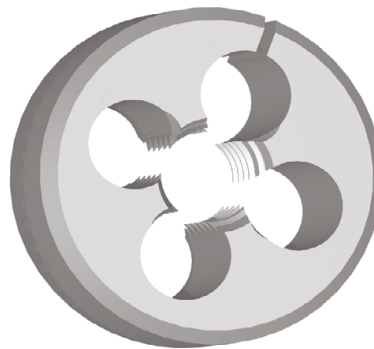
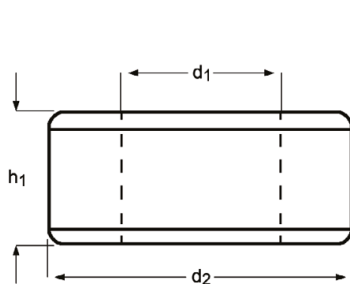

UNF	TPI	d_1 nom mm	d_2 Ø Inch	h_1 Inch	F330
4	48	2.85	13/16	1/4	F3304-48X13/16
5	44	3.18	13/16	1/4	F3305-44X13/16
6	40	3.51	13/16	1/4	F3306-40X13/16
8	36	4.17	13/16	1/4	F3308-36X13/16
10	32	4.83	13/16	1/4	F33010-32X13/16
10	32	4.83	1"	3/8	F33010-32X1
12	28	5.49	13/16	1/4	F33012-28X13/16
1/4	28	6.35	13/16	1/4	F3301/4X13/16
1/4	28	6.35	1"	3/8	F3301/4X1
1/4	28	6.35	1.1/2	1/2	F3301/4X1.1/2
5/16	24	7.94	1"	3/8	F3305/16X1
5/16	24	7.94	1.5/16	7/16	F3305/16X1.5/16
5/16	24	7.94	1.1/2	1/2	F3305/16X1.1/2
3/8	24	9.53	1"	3/8	F3303/8X1
3/8	24	9.53	1.5/16	7/16	F3303/8X1.5/16
3/8	24	9.53	1.1/2	1/2	F3303/8X1.1/2
7/16	20	11.11	1"	3/8	F3307/16X1
7/16	20	11.11	1.5/16	7/16	F3307/16X1.5/16
7/16	20	11.11	1.1/2	1/2	F3307/16X1.1/2
1/2	20	12.70	1.5/16	7/16	F3301/2X1.5/16
1/2	20	12.70	1.1/2	1/2	F3301/2X1.1/2
9/16	18	14.29	1.5/16	7/16	F3309/16X1.5/16
9/16	18	14.29	1.1/2	1/2	F3309/16X1.1/2
5/8	18	15.88	1.1/2	1/2	F3305/8X1.1/2
5/8	18	15.88	2"	5/8	F3305/8X2
3/4	16	19.05	1.1/2	1/2	F3303/4X1.1/2
3/4	16	19.05	2"	5/8	F3303/4X2
7/8	14	22.23	2"	5/8	F3307/8X2
1"	12	25.40	2"	5/8	F3301X2
1.1/8	12	28.58	3"	7/8	F3301.1/8X3
1.1/4	12	31.75	3"	7/8	F3301.1/4X3
1.1/2	12	38.10	3"	7/8	F3301.1/2X3

- F370**
- G(BSP) Filiere regolabili
 - G(BSP) Schneideisen - geschlitzt, verstellbar
 - G(BSP) Verstellbare snijplaat
 - G(BSP) Filières extensibles

F370	▪	1.1	1.2	1.3	3.1	3.2	3.3	7.1	7.2	7.3					
	•	1.4	2.1	2.2	3.4	4.3	5.1	5.2	5.3	6.1	6.2	6.3	7.4	8.1	8.2

F370

G

BS
1127:
1950

1.75XP

HSS



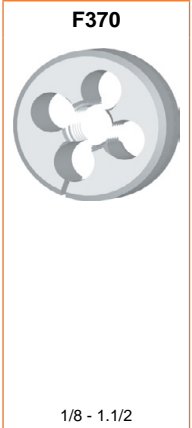
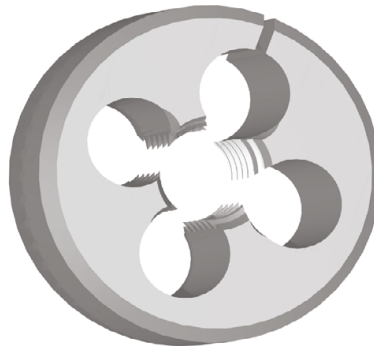
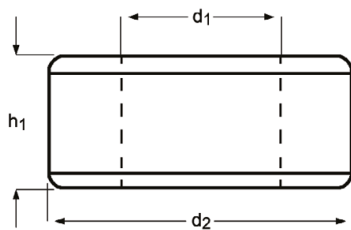

G(BSP)	TPI	d_1 nom mm	d_2 \emptyset Inch	h_1 Inch	F370
1/8	28	9.73	1"	3/8	F3701/8X1
1/4	19	13.16	1.5/16	7/16	F3701/4X1.5/16
3/8	19	16.66	1.1/2	1/2	F3703/8X1.1/2
1/2	14	20.96	2"	5/8	F3701/2X2
5/8	14	22.91	2"	5/8	F3705/8X2
3/4	14	26.44	2"	5/8	F3703/4X2
7/8	14	30.20	2.1/4	11/16	F3707/8X2.1/4
1"	11	33.25	2.1/4	11/16	F3701X2.1/4
1.1/4	11	41.91	3"	7/8	F3701.1/4X3
1.1/2	11	47.80	4"	1"	F3701.1/2X4

- F202**
- M Filiere esagonali
 - M Sechskant-Schneideisen
 - M Snijmoer
 - M Filières hexagonales

F202	▪	1.1	1.2	1.3	3.1	3.2	3.3	7.1	7.2	7.3						
	•	1.4	2.1	2.2	3.4	4.3	5.1	5.2	5.3	6.1	6.2	6.3	7.4	8.1	8.2	8.3

F202

M

DIN
382

6g

1.75XP

HSS

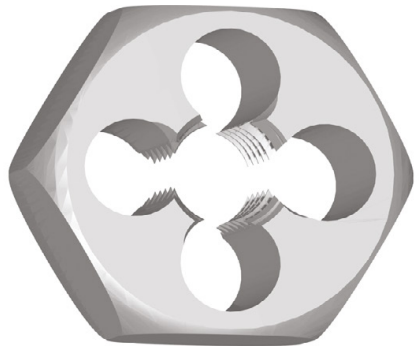
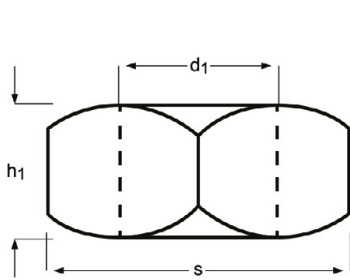

M	P mm	S mm	h ₁ mm	F202
3	0.50	19	5	F202M3
4	0.70	19	5	F202M4
5	0.80	19	7	F202M5
6	1.00	19	7	F202M6
7	1.00	22	9	F202M7
8	1.25	22	9	F202M8
10	1.50	27	11	F202M10
12	1.75	36	14	F202M12
14	2.00	36	14	F202M14
16	2.00	41	18	F202M16
18	2.50	41	18	F202M18
20	2.50	41	18	F202M20
22	2.50	50	22	F202M22
24	3.00	50	22	F202M24
27	3.00	60	25	F202M27
30	3.50	60	25	F202M30
36	4.00	60	25	F202M36

- F302**
- M Filiere esagonali
 - M Sechskant-Schneideisen
 - M Snijmoer
 - M Filières hexagonales

F302	▪	1.1	1.2	1.3	3.1	3.2	3.3	7.1	7.2	7.3						
	•	1.4	2.1	2.2	3.4	4.3	5.1	5.2	5.3	6.1	6.2	6.3	7.4	8.1	8.2	8.3

F302 **M** **BS 1127: 1950** **6g** **1.75XP** **HSS**  

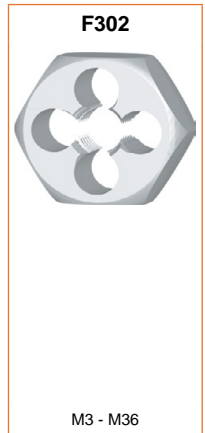
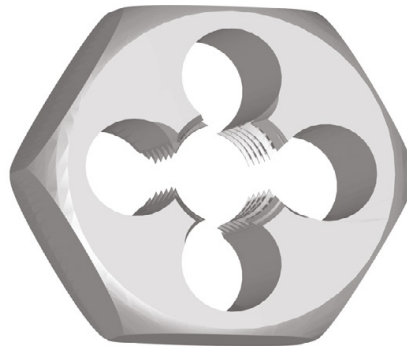
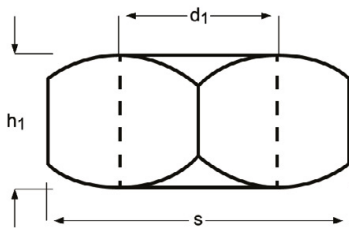

M	P mm	S decimal Inch	h ₁ Inch	F302
3	0.50	0.7100	1/4	F302M3
4	0.70	0.7100	1/4	F302M4
5	0.80	0.7100	1/4	F302M5
6	1.00	0.7100	1/4	F302M6
7	1.00	0.8200	5/16	F302M7
8	1.25	0.8200	5/16	F302M8
10	1.50	0.9200	3/8	F302M10
11	1.50	1.0100	7/16	F302M11
12	1.75	1.1000	1/2	F302M12
14	2.00	1.3000	5/8	F302M14
16	2.00	1.3000	5/8	F302M16
18	2.50	1.4800	11/16	F302M18
20	2.50	1.4800	11/16	F302M20
22	2.50	1.6700	13/16	F302M22
24	3.00	2.0500	15/16	F302M24
27	3.00	2.2200	1.1/16	F302M27
30	3.50	2.2200	1.1/16	F302M30
33	3.50	2.5800	1.1/8	F302M33
36	4.00	2.7600	1.1/4	F302M36

F312

- MF Filiere esagonali
- MF Sechskant-Schneideisen
- MF Snijmoer
- MF Filières hexagonales

F312	▪	1.1	1.2	1.3	3.1	3.2	3.3	7.1	7.2	7.3								
	•	1.4	2.1	2.2	3.4	4.3	5.1	5.2	5.3	6.1	6.2	6.3	7.4	8.1	8.2	8.3		

F312 MF BS 1127: 1950 6g 1.75XP HSS

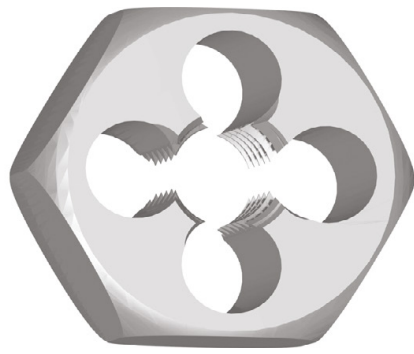
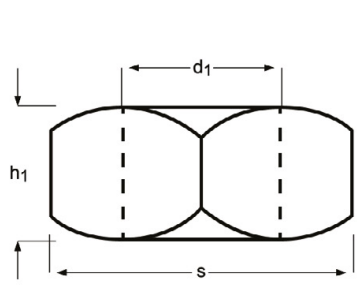

MF	P mm	S decimal Inch	h ₁ Inch	F312
8	0.75	0.8200	5/16	F312M8X.75
8	1.00	0.8200	5/16	F312M8X1.0
10	1.00	0.9200	3/8	F312M10X1.0
10	1.25	0.9200	3/8	F312M10X1.25
12	1.00	1.0100	7/16	F312M12X1.0
12	1.25	1.0100	7/16	F312M12X1.25
12	1.50	1.0100	7/16	F312M12X1.5
14	1.50	1.3000	5/8	F312M14X1.5
16	1.50	1.3000	5/8	F312M16X1.5
18	1.50	1.4800	11/16	F312M18X1.5
20	1.50	1.4800	11/16	F312M20X1.5
22	1.50	1.6700	13/16	F312M22X1.5
24	1.50	2.0500	15/16	F312M24X1.5
24	2.00	2.0500	15/16	F312M24X2.0

- F272**
- G(BSP) Filiere esagonali
 - G(BSP) Sechskant-Schneideisen
 - G(BSP) Snijmoer
 - G(BSP) Filières hexagonales

F272	▪	1.1	1.2	1.3	3.1	3.2	3.3	7.1	7.2	7.3						
	•	1.4	2.1	2.2	3.4	4.3	5.1	5.2	5.3	6.1	6.2	6.3	7.4	8.1	8.2	8.3

F272 **G** **DIN 382** **Class A** **1.75XP** **HSS**  

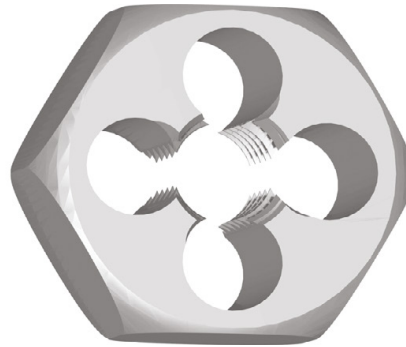
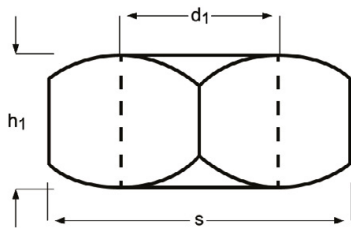

G(BSP)	TPI	d_1 nom mm	S mm	h_1 mm	F272
1/8	28	9.73	27	11	F2721/8
1/4	19	13.16	36	10	F2721/4
3/8	19	16.66	41	14	F2723/8
1/2	14	20.96	41	14	F2721/2
3/4	14	26.44	60	18	F2723/4
1"	11	33.25	60	18	F2721
1.1/4	11	41.91	70	20	F2721.1/4
1.1/2	11	47.80	85	22	F2721.1/2

C110	443	C831	482	S525	417	S813HA	394
C122	454	C835	480	S526	418	S813HB	394
C123	445	C837	479	S527	419	S814HA	408
C126	443	C907	456	S529	433	S814HB	408
C135	447	C908	466	S531	434	S822	392
C139	445	C920	457	S533	435	S823	395
C159	451	C922	463	S534	437	S902	397
C167	453	C948	467	S535	438	S903	399
C246	458	D200	485	S536	429	S904	412
C247	458	D400	492	S610	404	S922	397
C273	460	D402	493	S611	405	S933	399
C295	460	D420	492	S612	410	S944	412
C299	456	D422	493	S629	440	S991	442
C305	450	D745	486	S637	402		
C306	448	D747	488	S638	403		
C333	462	D750	491	S710	396		
C336	452	D751	491	S713	398		
C346	455	D752	490	S714	400		
C352	450	D753	490	S715	401		
C353	448	D763	485	S716	409		
C367	449	S216	411	S717	413		
C400	468	S217	413	S718	414		
C403	469	S218	414				

373 - 494



C407	466	S219	407	S739	441
C413	468	S225	417	S740	441
C428	464	S226	418	S761	415
C492	465	S227	419	S763	425
C500	470	S229	430	S765	420
C505	471	S231	431	S766	416
C700	484	S233	432	S767	428
C710	483	S260	415	S802HA	390
C800	472	S262	426	S802HB	390
C801	475	S264	421	S803HA	393
C810	473	S501	436	S803HB	393
C820	477	S511	439	S804HA	406
C822	476	S521	423	S804HB	406
C825	474	S523	424	S812HA	391
C830	481	S524	422	S812HB	391

Materiale	Material	Materiaal	Matière
Applicazione	Anwendung	Toepassing	Utilisation
Tipo	Typ	Type	Type
N° taglienti	Zähne	Aantal tanden	dent
Lunghezza di taglio	Schneidenlänge	Snijkantslengte	Longueur de coupe
Angolo d'Elica/ Angolo di spoglia frontale	Drallwinkel / Spanwinkel	Hellingshoek / Spaanhoek	Angle d'hélice / Angle de coupe
Codolo	Schaft	Schacht	Queue
Trattamento superficiale	Oberfläche	Oppervlaktebehandeling	Revêtement
Tolleranza	Toleranz	Tolerantie	Tolérance
Direzione	Einsatzmöglichkeit	Snijrichting	Direction
Normativa	Standard	Norm	Standard
■ Raccomandato	Sehr gut für die Anwendung	Uitstekend voor deze toepassing	Excellent pour les applications
● Accettabile	Gut für die Anwendung	Acceptabel voor deze toepassing	Acceptable pour les applications
Esempio 10 = Velocità periferica in m/min +/- 10%	Beispiel 10 = Schnittgeschwindigkeit (m/min) +/- 10%	Voorbeeld 10 = snijsnelheid in m/min +/- 10%	Exemple 10 = Vitesse périphérique en mètres/ minute +/- 10%
Codice prodotto	Produktbezeichnung	Productcode	Codes
Gamma diametri	Durchmesserbereich	Diameterreeks	Gamme

AMG	Italiano	Deutsch	Nederlands	Français
1.1	Acciaio dolce magnetico	Magnetweicheisen	Automatenstaal, zachtstaal	Acier doux magnétique
1.2	Acciaio da costruzione e da cementazione	Baustahl, Einsatzstahl	Constructiestaal, inzetstaal	Acier de construction, Acier de cémentation
1.3	Acciaio al carbonio	Kohlenstoffstahl	Koolstofstaal	Acier au carbone ordinaire
1.4	Acciaio legato	Legierter Stahl	Gelegeerd staal	Acier allié
1.5	Acciaio legato / Acciaio bonificato e temprato	Legierter und vergüteter Stahl	Gelegeerd en veredeld staal	Acier allié/ Acier trempé et revenu
1.6	Acciaio legato / Acciaio bonificato e temprato	Legierter und vergüteter Stahl	Hooggelegeerd veredeld staal	Acier allié/ Acier trempé et revenu
1.7	Acciaio legato/temprato	Legierter gehärteter Stahl	Gelegeerd en gehard staal	Acier allié trempé
1.8	Acciaio legato/temprato	Legierter gehärteter Stahl	Gelegeerd en gehard staal	Acier allié trempé
2.1	Acciaio inossidabile/automatico	Rostfreier Stahl, geschwefelt	Roestvast automatenstaal	Acier inoxydable de décolletage
2.2	Austenitico	Austenitisch	Austenitisch	Austénitique
2.3	Ferritico+Austenitico, Martensitico	Ferritisch+Austenitisch, Martensitisch	Ferritisch+Austenitisch, Martensitisch	Ferritique + Austénitique, Martensitique
2.4	Acciai inossidabili con indurimento da precipitazione	Vergüteter rostfreier Stahl	Precipitatiehardend roestvast staal	Acier inoxydable Trempé
3.1	Ghisa con grafite lamellare	Grauguss	Gietijzer Lamellair	Graphite lamellaire
3.2	Ghisa con grafite lamellare	Vergüteter Grauguss	Gietijzer Lamellair	Graphite lamellaire
3.3	Ghisa malleabile con grafite sferoidale	Kugelgraphitguss, Temperguss	Nodulair gietijzer / Smeedbaar gietijzer	Graphite nodulaire/ Fonte malléable
3.4	Ghisa malleabile con grafite sferoidale	Kugelgraphitguss, Temperguss	Nodulair gietijzer / Smeedbaar gietijzer	Graphite nodulaire/ Fonte malléable
4.1	Titanio non legato	Reintitan	Titaan, ongelegeerd	Titane, non-allié
4.2	Leghe di titanio	Titan-Legierungen	Titaan, gelegeerd	Titane, allié
4.3	Leghe di titanio	Titan-Legierungen	Titaan, gelegeerd	Titane, allié
5.1	Nichel non legato	Reinnickel	Nikkel, ongelegeerd	Nickel, non-allié
5.2	Leghe di nichel	Nickel-Legierungen	Nikkel, gelegeerd	Nickel, allié
5.3	Leghe di nichel	Nickel-Legierungen	Nikkel, gelegeerd	Nickel, allié
6.1	6.1 Rame	Kupfer	Koper	Cuivre
6.2	β-Ottone, Bronzo	Kurzspanendes Messing, Bronze	β-Messing, brons	β-Laiton, Bronze
6.3	α-Ottone	Langspanendes Messing	α-Messing	α-Laiton
6.4	Bronzo ad alta resistenza	Cu-Al-Fe-Legierung, (Ampco)	Extra-sterk brons	Bronze, haute résistance
7.1	Al, Mg, non legato	Al, Mg, unlegiert	Al, Mg, ongelegeerd	Al, Mg, non-allié
7.2	Leghe di Al, Si < 0.5%	Al legiert, Si<0.5 %	Al gelegeerd, Si < 0.5%	Al allié, Si < 0.5%
7.3	Leghe di Al, Si > 0.5% < 10%	Al legiert, Si>0.5 %<10 %	Al gelegeerd, Si > 0.5% < 10%	Al allié, Si > 0.5% < 10%
7.4	Leghe di Al, Si > 10% Rinforzate Whisker Leghe di Al, Leghe di Mg	Al legiert, Si>10 % Whisker verstärkte Al-Legierung, Mg-Legierung	Al gelegeerd, Si>10% whisker versterkt Al-gelegingen, Mg-gelegingen	Al allié, Si>10% Alliages d'Al ou Mg, céramique renforcée
8.1	Materiali termoplastici	Thermoplaste	Thermoplasten	Thermoplastiques
8.2	Materiali plastici termoidurenti	Duroplaste	Duraplasten	Plastiques thermodurcissables
8.3	Materiali plastici rinforzati	Faserverstärkte Kunststoffe	Versterkte kunststofmaterialen	Plastiques renforcés
9.1	Cermets (materiali metallo-ceramici)	Cermets (Metallkeramik)	Cermets (metal-ceramics)	Cermets (céramiques métalliques)
10.1	Grafite standard	Graphit	Standaard Grafiet	Graphite standard

	HM	HM	HM	HM	HM	HM	HM	HM	HM	HM	HM	HM	HM	HM	HM			
	N	N	N	N	N	N	N	N	N	N	N	N	N	N	N			
	Z ₂	Z ₂	Z ₂	Z ₂	Z ₂	Z ₃	Z ₃	Z ₃	Z ₃	Z ₂	Z ₂	Z ₂	Z ₃	Z ₃	Z ₃			
	λ 28° γ 9°	λ 28° γ 9°	λ 28° γ 9°	λ 28° γ 9°	λ 28° γ 9°	λ 28° γ 9°	λ 28° γ 9°	λ 28° γ 9°	λ 28° γ 9°	λ 28° γ 9°	λ 40° γ 10°	λ 30° γ 12°	λ 30° γ 12°	λ 40° γ 10°	λ 30° γ 12°			
	DIN 6535HA	DIN 6535HB	DIN 6535HA	DIN 6535HB	DIN 6535HA	DIN 6535HB	DIN 6535HA	DIN 6535HB	DIN 6535HA	DIN 6535HB	DIN 6535HA	DIN 6535HB	DIN 6535HA	DIN 6535HB	DIN 6535HA			
	Alcrona	Alcrona	Alcrona	Alcrona	Alcrona	Alcrona	Alcrona	Alcrona	Alcrona	Alcrona	AlCrN	TiAlN	AlCrN	TiAlN	TiAlN			
											h9	h10	h10	h9	h10			
	DIN 6527K	DIN 6527K	DIN 6527L	DIN 6527L	DIN 6527L	DIN 6527K	DIN 6527K	DIN 6527L	DIN 6527L	DIN 6527L	DORMER	DORMER	DORMER	DORMER	DORMER			
	S802HA	S802HB	S812HA	S812HB	S822	S803HA	S803HB	S813HA	S813HB	S823	S710	S902	S922	S713	S903	S933		
	1.00 - 20.00	1.80 - 20.00	2.00 - 20.00	2.00 - 20.00	2.00 - 20.00	1.00 - 20.00	1.80 - 20.00	2.00 - 20.00	2.00 - 20.00	2.00 - 20.00	1.00 - 20.00	2.00 - 20.00	2.00 - 20.00	1.50 - 20.00	2.00 - 20.00	2.00 - 20.00		
AMG	390	390	391	391	392	393	393	394	394	395	396	397	397	398	399	399	ISO	
1.1	260B	260B	210B	210B	180B	260B	260B	210B	210B	180B	140C	65B	95B	140C	65B	95B	P 1	
1.2	260B	260B	210B	210B	180B	260B	260B	210B	210B	180B	140C	65B	95B	140C	65B	95B	P 1	
1.3	155B	155B	125B	125B	110B	155B	155B	125B	125B	110B	130C	55B	80B	130C	55B	80B	P 2	
1.4	155B	155B	125B	125B	110B	155B	155B	125B	125B	110B	130C	50B	75B	130C	50B	75B	P 3	
1.5	115B	115B	90B	90B	80B	115B	115B	90B	90B	80B	120C	30B	45B	120C	30B	45B	P 4	
1.6	90B	90B	75B	75B	65B	90B	90B	75B	75B	65B			30B			30B	H 1	
1.7																		H 3
1.8																		H 4
2.1	105A	105A	75A	75A	70A	105A	105A	85A	85A	70A	80B			80B				M 1
2.2	70A	70A	55A	55A	50A	70A	70A	55A	55A	50A	70B			70B				M 3
2.3	70A	70A	55A	55A	50A	70A	70A	55A	55A	50A								M 2
2.4	50A	50A				50A	50A											S 2
3.1	180B	180B	145B	145B	125B	180B	180B	145B	145B	125B	170C	55B	80B	170C	55B	80B		K 1
3.2	110B	110B	85B	85B	75B	110B	110B	85B	85B	75B	150C	30B	45B	150C	30B	45B		K 2
3.3	145B	145B	115B	115B	100B	145B	145B	115B	115B	100B	130C	55B	80B	130C	55B	80B		K 3
3.4	95B	95B	75B	75B	65B	95B	95B	75B	75B	65B	120C	30B	45B	120C	30B	45B		K 4
4.1	170B	170B	140B	140B	120B	170B	170B	140B	140B	120B		65B	95B		65B	95B		S 1
4.2	115B	115B	90B	90B	80B	115B	115B	90B	90B	80B	70B	30B	45B	70B	30B	45B		S 2
4.3												15B	20B		15B	20B		S 3
5.1	165B	165B	130B	130B	115B	165B	165B	130B	130B	115B		65B	95B		65B	95B		S 1
5.2	35A	35A	25A	25A	25A	35A	35A	25A	25A	25A	70B			70B				S 2
5.3																		S 3
6.1	320C	320C	255C	255C	220C	320C	320C	255C	255C	220C		110C	155C		110C	155C		N 3
6.2	320C	320C	255C	255C	220C	320C	320C	255C	255C	220C		110C	155C		110C	155C		N 4
6.3	320C	320C	255C	255C	220C	320C	320C	255C	255C	220C		110C	155C		110C	155C		N 3
6.4	40B	40B	30C	30C	25B	40B	40B	30C	30C	25B		15B	20B		15B	20B		N 4
7.1	800C	800C	640C	640C	550C	800C	800C	640C	640C	550C		275C	390C		275C	390C		N 1
7.2	800C	800C	640C	640C	550C	800C	800C	640C	640C	550C		275C	390C		275C	390C		N 1
7.3	480C	480C	380C	380C	330C	480C	480C	380C	380C	330C		165C	235C		165C	235C		N 1
7.4	240B	240B	190B	190B	160B	240B	240B	190B	190B	160B								N 2
8.1	320C	320C	255C	255C	245C	320C	320C	255C	255C	245C		110C	155C		110C	155C		O
8.2	320C	320C	255C	255C	245C	320C	320C	255C	255C	245C		110C	155C		110C	155C		O
8.3												30B	45B		30B	45B		O
9.1																		H
10.1																		O

	HM	HM	HM	HM	HM	HM	HM	HM	HM	HM	HM	HM	HM	HM	HM	HM	
	N	N	W	W	W	W	N	N	N	N	N	N	N	N	N	N	
	Z 3	Z 3	Z 1	Z 2	Z 2	Z 2	Z 4	Z 4	Z 4	Z 4	Z 4	Z 4	Z 4	Z 4	Z 4	Z 4	
	$\lambda 40^\circ$ $\gamma 10^\circ$	$\lambda 40^\circ$ $\gamma 10^\circ$	$\lambda 25^\circ$ $\gamma 20^\circ$	$\lambda 30^\circ$ $\gamma 20^\circ$	$\lambda 30^\circ$ $\gamma 20^\circ$	$\lambda 30^\circ$ $\gamma 20^\circ$	$\lambda 34^\circ$ $\gamma 9^\circ$	$\lambda 34^\circ$ $\gamma 9^\circ$	$\lambda 40^\circ$ $\gamma 3^\circ$	$\lambda 34^\circ$ $\gamma 9^\circ$	$\lambda 34^\circ$ $\gamma 9^\circ$	$\lambda 40^\circ$ $\gamma 10^\circ$	$\lambda 40^\circ$ $\gamma 10^\circ$	$\lambda 40^\circ$ $\gamma 3^\circ$	$\lambda 30^\circ$ $\gamma 12^\circ$	$\lambda 30^\circ$ $\gamma 12^\circ$	
	DIN 6535HA	DIN 6535HA	DIN 6535HA	DIN 6535HA	DIN 6535HA	DIN 6535HA	DIN 6535HA	DIN 6535HA	DIN 6535HA	DIN 6535HA	DIN 6535HA	DIN 6535HA	DIN 6535HA	DIN 6535HA	DIN 6535HA	DIN 6535HA	
	AlCrN	AlCrN	Hi	Hi	Hi	Hi	Alcrona	Alcrona	AlTiN	Alcrona	Alcrona	AlCrN	Diamond	AlTiN		TiAlN	
	h9	h9	h9	h9	h9	h9	h10	h10	h9	h10	h10	h9	h9	h9	h12	h12	
							DIN 6527K	DIN 6527K	DORMER	DIN 6527L	DIN 6527L	DORMER	DORMER	DORMER	DORMER	DORMER	
	S714	S715	S637	S638	S610	S611	S804HA	S804HB	S219	S814HA	S814HB	S716	S612	S216	S904	S944	
	3.00 - 20.00	3.00 - 20.00	2.00 - 12.00	6.20 - 20.30	3.00 - 20.00	6.00 - 20.00	2.00 - 25.00	2.00 - 25.00	3.00 - 20.00	2.00 - 25.00	2.00 - 25.00	2.00 - 20.00	1.00 - 12.00	2.00 - 20.00	2.00 - 20.00	2.00 - 20.00	
AMG	400	401	402	403	404	405	406	406	407	408	408	409	410	411	412	412	
1.1	■110C	■70C					■360B	■360B		■270B	■270B	■140C			■95B	■140B	P 1
1.2	■110C	■70C					■300B	■300B		■225B	■225B	■140C			■95B	■140B	P 1
1.3	■100C	■65C					■230B	■230B		■175B	■175B	■130C			■80B	■120B	P 2
1.4	■100C	■65C					■230B	■230B		■175B	■175B	■130C			■70B	■105B	P 3
1.5	■95C	■60C					■165B	■165B		■125B	■125B	■120C			■55B	■80B	P 4
1.6							■130B	■130B	■90C	●100B	●100B			■90C	●30B	●45B	H 1
1.7																	H 3
1.8																	H 4
2.1	■65B	■40B					■165A	■165A		■125A	■125A	■80B					M 1
2.2	■55B	■35B					■110A	■110A		●85A	●85A	■70B					M 3
2.3							■110A	■110A	■70B	●85A	●85A			■70B			M 2
2.4							●75A	●75A	■50B					■50B			S 2
3.1	■135C	■85C					■275B	■275B		■205B	■205B	■170C			■80B	■120B	K 1
3.2	■120C	■75C					■165B	■165B		■125B	■125B	■150C			●55B	■80B	K 2
3.3	■100C	■65C					■165B	■165B		■125B	■125B	■130C			■70B	■105B	K 3
3.4	■95C	■60C					■135B	■135B		■105B	■105B	■120C			●55B	■80B	K 4
4.1							●275B	●275B		●205B	●205B				■95B	■140B	S 1
4.2	■55B	■35B					●140B	●140B		●105B	●105B	■70B			●40B	●60B	S 2
4.3									■50B					■50B	●30B	●45B	S 3
5.1							●275B	●275B		●205B	●205B				■135B	■200B	S 1
5.2	■55B	■35B					●55A	●55A		●40A	●40A	■70B			●30A	●45A	S 2
5.3									■50B					■50B	●25A	●35A	S 3
6.1	●200E	●125E	■350E	■400E	■350E	■280E	●320C	●320C		●255C	●255C				■110C	■155C	N 3
6.2	●190E	●115E	■300E	■345E	■300E	■240E	■320C	■320C		■255C	■255C				■110C	■155C	N 4
6.3	●175E	●110E	■250E	■290E	■250E	■200E	■320C	■320C		■255C	■255C				■110C	■155C	N 3
6.4	●160E	●100E	■200E	■230E	■200E	■160E	■40B	■40B		■32C	■32C				●15B	●20B	N 4
7.1	●200E	●125E	■600E	■690E	■600E	■480E	●800C	●800C		●640C	●640C				●275C	●390C	N 1
7.2	●190E	●115E	■500E	■575E	■500E	■400E	●800C	●800C		●640C	●640C				●275C	●390C	N 1
7.3	●175E	●110E	■400E	■460E	■400E	■320E	●480C	●480C		●380C	●380C				●165C	●235C	N 1
7.4	●160E	●100E	■350E	■400E	■350E	■280E	●240B	●240B		●190B	●190B						N 2
8.1			■800E	■980E	■800E	■640E	●320C	●320C		●255C	●255C				●110C	●155C	O
8.2			■800E	■980E	■800E	■640E	●320C	●320C		●255C	●255C				●110C	●155C	O
8.3															●55B	●80B	O
9.1																	H
10.1													■350A				O

	HM	HM	HM	HM	HM	HM	HM	HM	HM	HM	HM	HM	HM	HM	HM	HM		
	N	N	N	N	N	N	N	N	N	N	N	N	NR	NR	N	N		
	Z 4	Z 4	Z 4	Z 4	Z 4	Z 4	Z 4	Z 6-8	Z 6-8	Z 6-8	Z 6-8	Z 6-8	Z 4	Z 4	Z 4	Z 4		
	$\lambda 40^\circ$ $\gamma 10^\circ$	$\lambda 40^\circ$ $\gamma 3^\circ$	$\lambda 40^\circ$ $\gamma 10^\circ$	$\lambda 40^\circ$ $\gamma 3^\circ$	$\lambda 40^\circ$ $\gamma 10^\circ$	$\lambda 40^\circ$ $\gamma 4^\circ$	$\lambda \neq$ $\gamma 10^\circ$	$\lambda 50^\circ$ $\gamma 3^\circ$	$\lambda 50^\circ$ $\gamma 26^\circ$	$\lambda 50^\circ$ $\gamma 3^\circ$	$\lambda 50^\circ$ $\gamma 26^\circ$	$\lambda 50^\circ$ $\gamma 3^\circ$	$\lambda 50^\circ$ $\gamma 26^\circ$	$\lambda 40^\circ$ $\gamma 10^\circ$	$\lambda 40^\circ$ $\gamma 4^\circ$	$\lambda 40^\circ$ $\gamma 6^\circ$	$\lambda 45^\circ$ $\gamma 10^\circ$	
	DIN 6535HA	DIN 6535HA	DIN 6535HA	DIN 6535HA	DIN 6535HA	DIN 6535HA	DIN 6535HA	DIN 6535HA	DIN 6535HA	DIN 6535HA	DIN 6535HA	DIN 6535HA	DIN 6535HA	DIN 6535HA	DIN 6535HB	DIN 6535HA	DIN 6535HA	
	AICrN	AlTiN	AICrN	AlTiN	AICrN	AICrN	TiSiN	AlTiN	TiSiN	AlTiN	TiSiN	AlTiN	TiSiN	AICrN	AICrN	TiSiN	TiSiN	
	h9	h9	h9	h9	h9	h9	h9	h9	h9	h9	h9	h9	h9	h9	h9	h9	h9	
	DORMER	DORMER	DORMER	DORMER	DORMER	DORMER	DORMER	DORMER	DORMER	DORMER	DORMER	DORMER	DORMER	DORMER	DORMER	DORMER	DORMER	
	S717	S217	S718	S218	S761	S260	S766	S225	S525	S226	S526	S227	S527	S765	S264	S524	S521	
	3.00 - 20.00	3.00 - 20.00	3.00 - 20.00	3.00 - 20.00	3.00 - 20.00	3.00 - 20.00	4.00 - 20.00	3.00 - 20.00	3.00 - 20.00	3.00 - 20.00	3.00 - 20.00	6.00 - 20.00	3.00 - 20.00	6.00 - 20.00	6.00 - 20.00	3.00 - 16.00	3.00 - 16.00	
AMG	413	413	414	414	415	415	416	417	417	418	418	419	419	420	421	422	423	ISO
1.1	■110C		■70C		■140D		■140D		■140D					■140D				P 1
1.2	■110C		■70C		■140D		■140D		■140D					■140D				P 1
1.3	■100C		■65C		■130D		■130D		■130D					■130D				P 2
1.4	■100C		■65C		■130D		■130D		■130D					■130D				P 3
1.5	■95C		■60C		■120D		■120D		■120D					■120D				P 4
1.6		■72C		■45C		■110D		■90C		■72C		■45C			■110D			H 1
1.7					■85B			■70A		■56A		■35A		■85B	■56A	■70A		H 3
1.8								■50A		■40A		■25A			■40A	■50A		H 4
2.1	■65B		■40B		■80C		■80C							■80C				M 1
2.2	■55B		■35B		■70C		■70C							■70C				M 3
2.3		■56B		■35B		■70C		■70B		■56B		■35B			■70C			M 2
2.4		■40B		■25B		■50C		■50B		■40B		■25B			■50C			S 2
3.1	■135C		■85C		■170D		■170D							■170D				K 1
3.2	■120C		■75C		■150D		■150D							■150D				K 2
3.3	■100C		■65C		■130D		■130D							■130D				K 3
3.4	■95C		■60C		■120D		■120D							■120D				K 4
4.1																		S 1
4.2	■55B		■35B		■70C		■70C							■70C				S 2
4.3		■40B		■25B		■50C		■50B		■40B		■25B			■50C			S 3
5.1																		S 1
5.2	■55B		■35B		■70C		■70C							■70C				S 2
5.3		■40B		■25B		■50C		■50B		■40B		■25B			■50C			S 3
6.1	●200E		●125E															N 3
6.2	●190E		●115E															N 4
6.3	●175E		●110E															N 3
6.4	●160E		●100E															N 4
7.1	●200E		●125E															N 1
7.2	●190E		●115E															N 1
7.3	●175E		●110E															N 1
7.4	●160E		●100E															N 2
8.1																		O
8.2																		O
8.3																		O
9.1																		H
10.1																		O

	HM	HM	HM	HM	HM	HM	HM	HM	HM	HM	HM	HM	HM	HM	HM	HM	HM	HM	
	N	N	N	N	N	N	N	N	N	N	N	N	N	N	N	W	N	N	
	Z 4	Z 4	Z 4	Z 4	Z 4-6	Z 2	Z 2	Z 2	Z 2	Z 2	Z 2	Z 4	Z 4	Z 4	Z 2	Z 2	Z 2		
	$\lambda 40^\circ$ $\gamma -6^\circ$	$\lambda 40^\circ$ $\gamma 10^\circ$	$\lambda 40^\circ$ $\gamma 4^\circ$	$\lambda \neq 40^\circ$ $\gamma 10^\circ$	$\lambda 25^\circ$ $\gamma 0^\circ$	$\lambda 30^\circ$ $\gamma 3^\circ$	$\lambda 30^\circ$ $\gamma 3^\circ$	$\lambda 30^\circ$ $\gamma 3^\circ$	$\lambda 30^\circ$ $\gamma -10^\circ$	$\lambda 30^\circ$ $\gamma -10^\circ$	$\lambda 30^\circ$ $\gamma 10^\circ$	$\lambda 30^\circ$ $\gamma -10^\circ$	$\lambda 30^\circ$ $\gamma -10^\circ$	$\lambda 30^\circ$ $\gamma 10^\circ$	$\lambda 30^\circ$ $\gamma 15^\circ$	$\lambda 40^\circ$ $\gamma 10^\circ$	$\lambda 40^\circ$ $\gamma 10^\circ$		
	DIN 6535HA	DIN 6535HA	DIN 6535HA	DIN 6535HA	DIN 6535HA	DIN 6535HA	DIN 6535HA	DIN 6535HA	DIN 6535HA	DIN 6535HA	DIN 6535HA	DIN 6535HA	DIN 6535HA	DIN 6535HA	DIN 6535HA	DIN 6535HA	DIN 6535HA		
	TiSiN	AlCrN	AlCrN	TiSiN	TiSiN	TiSiN	TiSiN	TiSiN	TiSiN	TiSiN	X-CEED	TiSiN	TiSiN	X-CEED	Hi	AlTiN	AlTiN		
	h9	h9	h9	h9	h9	h9	h9	h9	h9	h9	h9	h9	h9	h9	h9	h9	h9		
	S523	S763	S262	S767	S536	S229	S231	S233	S529	S531	S533	S501	S534	S535	S511	S629	S739	S740	
	1.50 - 16.00	3.00 - 20.00	3.00 - 20.00	4.00 - 20.00	6.00 - 12.00	1.50 - 16.00	1.50 - 16.00	2.00 - 16.00	1.50 - 16.00	1.50 - 16.00	2.00 - 16.00	1.00 - 16.00	3.00 - 16.00	3.00 - 16.00	3.00 - 16.00	3.00 - 20.00	3.00 - 20.00	3.00 - 20.00	
AMG	424	425	426	428	429	430	431	432	433	434	435	436	437	438	439	440	441	441	ISO
1.1		■140D		■140D								■181B			■230B		■140C	■140C	P 1
1.2		■140D		■140D								■181B			■192B		■140C	■140C	P 1
1.3		■130D		■130D								■118B			■153B		■130C	■130C	P 2
1.4		■130D		■130D								■118B			■153B		■130C	■130C	P 3
1.5		■120D		■120D								■90B			■115B		■120C	■120C	P 4
1.6			■110D			■630C	■500C	■315C				■72B			■92B				H 1
1.7	■70A		■85B		■105E				■330A	■260A	■165A	●45A	■330A	■260A	●61A				H 3
1.8	■50A				■75E				■280A	■225A	■140A		■280A	■225A					H 4
2.1		■80C		■80C								■81A			■115A		■80B	■80B	M 1
2.2		■70C		■70C								■54A			■76A		■70B	■70B	M 3
2.3			■70C			■540B	■430B	■270B				■54A			■76A				M 2
2.4			■50C			■315B	■250B	■155B											S 2
3.1		■170D		■170D								■136B			■192B		■170C	■170C	K 1
3.2		■150D		■150D								■81B			■115B		■155C	■155C	K 2
3.3		■130D		■130D								■109B			■115B		■145C	■145C	K 3
3.4		■120D		■120D								■72B			■96B		■130C	■130C	K 4
4.1												■136B			■192B				S 1
4.2		■70C		■70C								■90B			■96B		■70B	■70B	S 2
4.3			■50C			■315B	■250B	■155B				■45B			■61B				S 3
5.1												■136B			■192B				S 1
5.2		■70C		■70C								■27A			■38A		■70B	■70B	S 2
5.3			■50C			■315B	■250B	■155B				■22A			■30A				S 3
6.1												■363C			●384C	■350E	■250E	■250E	N 3
6.2												■363C			●384C	■300E	■235E	■235E	N 4
6.3												■363C			●384C	■250E	■220E	■220E	N 3
6.4												■54B			■61B	■200E	■200E	■200E	N 4
7.1												■950C			●950C	■600E	■250E	■250E	N 1
7.2												■950C			●950C	■500E	■235E	■235E	N 1
7.3												■681C			■576C	■400E	■220E	■220E	N 1
7.4												■363B			■307B	■350E	■200E	■200E	N 2
8.1												■318C			●307C	■800E			O
8.2												■318C			■307C	■800E			O
8.3												■318B			■307B				O
9.1												■5A			■9A				H
10.1																			O



S991
Set

HSS-E PM	HSS-E PM	HSS-E PM	HSS-E PM	HSS-E	HSS-E PM	HSS-E PM	HSS-E PM	HSS-E PM	HSS-E PM	HSS-E	HSS-E PM	HSS-E	
N	N	N	N	N	N	N	N	N	N	N	W	W	N
Z 2	Z 2	Z 2	Z 2	Z 2	Z 3	Z 3	Z 3	Z 3	Z 3	Z 3	Z 2	Z 3	Z 2
$\lambda 30^\circ$ $\gamma 12^\circ$	$\lambda 30^\circ$ $\gamma 12^\circ$	$\lambda 30^\circ$ $\gamma 12^\circ$	$\lambda 30^\circ$ $\gamma 12^\circ$	$\lambda 30^\circ$ $\gamma 12^\circ$	$\lambda 30^\circ$ $\gamma 12^\circ$	$\lambda 30^\circ$ $\gamma 12^\circ$	$\lambda 30^\circ$ $\gamma 12^\circ$	$\lambda 40^\circ$ $\gamma 15^\circ$	$\lambda 30^\circ$ $\gamma 12^\circ$	$\lambda 30^\circ$ $\gamma 12^\circ$	$\lambda 40^\circ$ $\gamma 20^\circ$	$\lambda 40^\circ$ $\gamma 25^\circ$	$\lambda 30^\circ$ $\gamma 12^\circ$
DIN 1835B	DIN 1835B	DIN 1835B	DIN 1835B	DIN 1835B	DIN 1835B	DIN 1835B	DIN 1835B	DIN 1835B	DIN 1835B	DIN 1835B	DIN 1835B	DIN 1835B	DIN 1835A
	TICN		TICN				Alcrona		Alcrona				
e8	e8	e8	e8	e8	e8 h10	e8 h10	e8	e8	e8	e8	e8	k10	js14

C110	C126	C123	C139	C135	C306	C353	C367	C305	C352	C159	C336	C167
1.00 - 40.00	1.00 - 30.00	1/16 - 30.00	2.00 - 25.00	2.00 - 20.00	3.00 - 30.00	3.00 - 30.00	2.00 - 20.00	2.00 - 32.00	3.00 - 20.00	2.00 - 20.00	10.00 - 30.00	6.00 - 16.00

AMG	442	443	443	445	445	447	448	448	449	450	450	451	452	453	ISO
1.1		■60A	■135A	■55A	■120A	■50A	●53A	●145A	■146A	●56A	■135A	■50A	●55A	■50A	P 1
1.2		■50A	■105A	■45A	■95A	■40A	■49A	■120A	■117A	■44A	■105A	●40A	●44A	■40A	P 1
1.3		●40B	■95B	■40B	■85B	●35B	■41B	■100B	■102B	■39B	■95B	●35B	●38B	●35B	P 2
1.4		●35B	■80B	■35B	■70B	●30B	●35B	■85B	●87B	●33B	■80B			●30B	P 3
1.5			●55C		●50C			■60C			■55C				P 4
1.6			●25C		●20C			●25C			●25C				H 1
1.7															H 3
1.8															H 4
2.1		●30F	●45F	●25F	●45F	●25F	●26F	●50F	■67F	●26F	●50F	●23F	●25F	●25F	M 1
2.2								●45F	■55F		●40F	●19F	●21F		M 3
2.3			●25F		●25F			●30F	■35F		●25F				M 2
2.4								■25F							S 2
3.1		●35A	■60A	●30A	■55A	●30A	●32A	■65A		●30A	■60A			●30A	K 1
3.2		●30A	■50A	●25A	■45A	●25A	●27A	■55A		●25A	■50A			●25A	K 2
3.3		●50B	■90B	●45B	■80B	●40B	●48B	■95B		●45B	■90B			●40B	K 3
3.4		●30B	■55B	●30B	■50B	●25B	●30B	■60B		●27B	■55B			●25B	K 4
4.1		■35D	■45D	■30D	■45D	●30D	■33D	■50D	●50D	■29D	■45D	●28D	●30D	●30D	S 1
4.2		●25D	■40D	●25D	■35D	●25D	●26D	■40D		●24D	■35D			●25D	S 2
4.3			●15D		●15D			●20D			●15D				S 3
5.1		■60D	■130D	■50D	■115D	■50D	■58D	■140D	●140D	■51D	■125D	●48D	●52D	■50D	S 1
5.2		●15C	■25C	●15C	■25C	●15C	●15C	■30C		■13C	■25C			●15C	S 2
5.3			●10D		●10D			●15D			●10D				S 3
6.1		■85C	■190C	■80C	■170C	■70C	■110C	■210C	■209C	■100C	■190C	■100C	■100C	■75C	N 3
6.2		■85C	■190C	■80C	■170C	■70C	■110C	■210C	■209C	■100C	■190C	■100C	■100C	■75C	N 4
6.3		■85C	■190C	■80C	■170C	■70C	■110C	■210C	■209C	■100C	■190C	■100C	■100C	■75C	N 3
6.4			●25C		●25C			●30C			●25C				N 4
7.1		●220E	●480E	●200E	●435E	●180E			■528E			■250E	■250E	●200E	N 1
7.2		●220E	●480E	●200E	●435E	●180E	●219E	●530E	■528E	●198E	●480E	■250E	■250E	●200E	N 1
7.3		●85E	●190E	●80E	●170E	●70E	●86E	●210E	●209E	●79E	●190E	■100E	■100E	●75E	N 1
7.4			●95A		●85A			●105A			●95A				N 2
8.1		●90C	●190C	●80C	●175C	●70C	●72C	●210C	●209C	●65C	●190C	■100C	■100E	●80C	O
8.2												■100C	■100E		O
8.3															O
9.1															H
10.1															O

	HSS-E	HSS-E	HSS-E PM	HSS-E PM	HSS-E PM	HSS-E PM	HSS-E PM	HSS-E PM	HSS-E PM	HSS-E PM	HSS-E PM	HSS-E PM	HSS-E PM	
	N	N	N	N	N	N	N	N	N	W	HRA	HRA	HRA	
	Z 2	Z 3	Z 3-5	Z 3-6	Z 3-5	Z 4-8	Z 4-6	Z 4-6	Z 4-6	Z 3	Z 3-4	Z 4-6	Z 3-6	
	$\lambda 30^\circ$ $\gamma 12^\circ$	$\lambda 30^\circ$ $\gamma 12^\circ$	$\lambda 45^\circ$ $\gamma 12^\circ$	$\lambda 45^\circ$ $\gamma 12^\circ$	$\lambda 45^\circ$ $\gamma 12^\circ$	$\lambda 30^\circ$ $\gamma 12^\circ$	$\lambda 30^\circ$ $\gamma 12^\circ$	$\lambda 30^\circ$ $\gamma 12^\circ$	$\lambda 30^\circ$ $\gamma 12^\circ$	$\lambda 40^\circ$ $\gamma 25^\circ$	$\lambda 35^\circ$ $\gamma 12^\circ$	$\lambda 35^\circ$ $\gamma 12^\circ$	$\lambda 35^\circ$ $\gamma 12^\circ$	
	DIN 1835A	DIN 1835B	DIN 1835B	DIN 1835B	DIN 1835B	DIN 1835B	DIN 1835B	DIN 1835B	DIN 1835B	DIN 1835B	DIN 1835B	DIN 1835B	DIN 1835B	
				Alcrona	Alcrona		TiCN		TiCN		Alcrona	Alcrona	Alcrona	
	e8	e8	k10	k10	k10	k10	k10	k10	k10	k10	k12	k12	k12	
	DORMER	DIN 844L	DIN 844K	DIN 844K	DIN 844L	DIN 844K	DIN 844K	DIN 844L	DIN 844L	DIN 844L	DIN 844K	DIN 844K	DIN 844L	
	C122	C346	C299	C907	C920	C247	C246	C273	C295	C333	C922	C428	C492	
	5.00 - 22.00	3.00 - 20.00	3.00 - 20.00	3.00 - 32.00	6.00 - 25.00	2.00 - 50.00	2.00 - 25.00	2.00 - 40.00	2.00 - 40.00	10.00 - 30.00	6.00 - 32.00	6.00 - 40.00	6.00 - 30.00	
AMG	454	455	456	456	457	458	458	460	460	462	463	464	465	ISO
1.1	■45A	●45A				■55S	■120S	■50S	■110S					P 1
1.2	■36A	■35A				■45S	■95S	■50S	■85S					P 1
1.3	●31B	●30B	■37T	■95T	■85T	■40T	■85T	■35T	■75T		●95H	●93H	■83H	P 2
1.4	●27B	●25B	■33T	■80T	■70T	●35T	■70T	■30T	■65T		■80H	■79H	■71H	P 3
1.5			■22U	■55U	■50U		●50U		●45U		■55I	■54I	■49I	P 4
1.6			●10U	■25U	■20U		●20U				■25I	■24I	■21I	H 1
1.7														H 3
1.8														H 4
2.1	●20F	●20F	■26Y	■50Y	■45Y	●25Y	●45Y	●10Y	●40Y		■50L	■48L	■43L	M 1
2.2			●21Y	■40Y	■35Y						■40L	■40L	■36L	M 3
2.3			■13Y	■25Y	■25Y		●25Y		●20Y		■25L	■26L	■23L	M 2
2.4														S 2
3.1	●25A	●25A	■30S	■60S	■55S	●30S	■55S	●25S	■50S		■60G	■61G	■55G	K 1
3.2	●20A	●20A	■25S	■50S	■45S	●25S	■45S	●20S	■40S		■50G	■50G	■45G	K 2
3.3	●36B	●35B	■45T	■90T	■80T	●45T	■79T	●40T	■70T		■90H	■88H	■79H	K 3
3.4	●22B	●20B	■27T	■55T	■50T	●25T	■49T	●25T	■45T		■55H	■55H	■49H	K 4
4.1	■25D	■25D	■29V	■45V	●40V	■30V	■43V	■25V	■40V		■45J	●46J	●41J	S 1
4.2	■20D	■20D	■57V	■85V	■35V	●25V	■35V	●20V	■30V		■35J	■37J	■34J	S 2
4.3			■10V	■15V	■15V		●15V		●15V		■15J	■16J	■15J	S 3
5.1	■43D	■45D	■51V	■125V	■115V	■50V	■116V	■45V	■105V		●125J	●127J	●114J	S 1
5.2	●11C	●10C	■13U	■25U	■25U	●15U	■24U	●10U	■20U		■25I	■27I	■24I	S 2
5.3			■5V	■10V	■10V		●10V		●10V		■10J	■11J	■10J	S 3
6.1	■112C	■70C				■80U	■170U	■70U	■155U	■90C				N 3
6.2	■112C	■70C	■100U	■190U	■170U	■80U	■170U	■70U	■155U	■90C	■190I	■190I	■170I	N 4
6.3	■112C	■70C				■80U	■170U	■70U	■155U	■90C				N 3
6.4							●25U		●20U		●25I	●25I	●23I	N 4
7.1	●270E	●180E				●200X	●435X	●180X	●390X	■225E				N 1
7.2	●270E	●180E				●200X	●435X	●180X	●390X	■225E				N 1
7.3	●81E					●80X	●170X	●70X	●155X	■90E				N 1
7.4			■39S	■95S	■85S		●85S		●75S		■95G	■95G	■85G	N 2
8.1	●112C	●70C				●80U	●175U	●70U	●155U	■90E				O
8.2										■90E				O
8.3														O
9.1														H
10.1														O

	HSS-E PM	HSS-E PM	HSS-E PM	HSS-E	HSS-E	HSS-E	HSS-E	HSS-E	HSS-E	HSS	HSS-E	
	Z 4-6	Z 4-6	Z 4-6	Z 4-6	Z 4-6	Z 4-6	Z 2	Z 2	Z 6-8	Z 6-8	Z 8-12	
	$\lambda 35^\circ$ $\gamma 12^\circ$	$\lambda 35^\circ$ $\gamma 12^\circ$	$\lambda 35^\circ$ $\gamma 12^\circ$	$\lambda 30^\circ$ $\gamma 12^\circ$	$\lambda 30^\circ$ $\gamma 12^\circ$	$\lambda 30^\circ$ $\gamma 12^\circ$	$\lambda 30^\circ$ $\gamma 12^\circ$	$\lambda 30^\circ$ $\gamma 12^\circ$	$\lambda 15^\circ$ $\gamma 10^\circ$	$\lambda 12^\circ$ $\gamma 10^\circ$	$\lambda 15^\circ$ $\gamma 15^\circ$	
	DIN 1835B	DIN 1835B	DIN 1835B	DIN 1835B	DIN 1835B	DIN 1835B	DIN 1835B	DIN 1835B	DIN 1835 B	DIN 1835D	DIN 1835B	
	k12	k12	k12	k12	k12	k12	e8	e8	d11	d11	js16	
	DIN 844K	DIN 844K	DIN 844L	DIN 844K	DIN 844K	DIN 844L	DIN 327D	DIN 844K	DIN 851	DORMER	DORMER	
	C407	C908	C948	C400	C413	C403	C500	C505	C800	C810	C825	
	6.00 - 20.00	6.00 - 32.00	6.00 - 32.00	6.00 - 20.00	6.00 - 20.00	10.00 - 50.00	2.00 - 25.00	3.00 - 30.00	11.00 - 50.00	12.50 - 40.00	40.00 - 63.00	
AMG	466	466	467	468	468	469	470	471	472	473	474	ISO
1.1	■55G			●50G	●100G	●45G	■55S	■50S	■35P	■25P	■35P	P 1
1.2	■44G			■40G	■80G	■35G	■45S	■40S	■35P	■25P	■30P	P 1
1.3	■38H	■93H	■83H	■35H	■70H	■30H	●40T	●35T	■30O	■20O	■30O	P 2
1.4	■33H	■79H	■71H	●30H	■60H	●25H	●35T	●30T	■25O	■15O	■20O	P 3
1.5	■22I	■54I	■49I	●40I	●40I	■25I	●35T	●30T	■20N	●10N	■15N	P 4
1.6	●10I	●24I	■21I	●20I	●20I				■15N	●10N	■10N	H 1
1.7												H 3
1.8												H 4
2.1	■25L	■48L	■43L	●25L	●35L	●20L	●25Y	●25Y	■20M	■15M	■15M	M 1
2.2	●21L	■40L	■36L						■15M	●10M	■10M	M 3
2.3	■13L	■26L	■23L		●20L				■10M	●10M	■10M	M 2
2.4												S 2
3.1	■30G	■61G	■55G	●30G	■45G	●25G	●30S	●30S	■20P	■20P	■25P	K 1
3.2	■25G	■50G	■45G	●25G	■35G	●20G	●25S	●25S	■20P	■20P	■20P	K 2
3.3	■44H	■88H	■79H	●40H	■65H	■35H	●45T	●40T	■30O	■20O	■30O	K 3
3.4	■27H	■55H	■49H	●25H	■40H	●20H	●30T	●25T	■20O	■10O	■20O	K 4
4.1	●30J	●46J	●41J	●30J	●35J	●25J	■30V	■30V	■30P	■20P	■35P	S 1
4.2	■25J	■37J	■34J	●25J	■30J	●20J	●25V	●25V	■20P	●15P	■20P	S 2
4.3	■11J	■16J	■15J		●10J				■10O	●5O	■10O	S 3
5.1	●52J	●127J	●114J	●50J	●95J	●45J	■50V	■50V	■35P	■25P	■35P	S 1
5.2	■14I	■27I	■24I	●15I	●20I	●10I	●15U	●15U	■10O	●5O	●5O	S 2
5.3	■6J	■11J	■10J		●10J				■5N	●5N	■5N	S 3
6.1				●70I	●140I	●65I	■85U	■80U	■100Q	■50Q	■30Q	N 3
6.2	■100I	■190I	■170I	■70I	■140I	■65I	■85U	■80U	■100P	■55P	■35P	N 4
6.3				■70I	■140I	■65I	■85U	■80U	■35P	■20P	■35P	N 3
6.4	●13I	●25I	●23I		●20I				■15O	■5O	■10O	N 4
7.1							●220X	●200X	■250R	■60R	■70R	N 1
7.2				●180K	●360K	●160K	●220X	●200X	■250R	■50R	■70R	N 1
7.3				●70K	●140K	●65K	●85X	●80X	■65R	■30R	■30R	N 1
7.4	●39G	●95G	■85G		●70G				■45Q	●20Q	■20Q	N 2
8.1				●70I	●145I	●65I	●90U	●80U	■100R	●50R	■35R	O
8.2												O
8.3												O
9.1												H
10.1									■45Q	●20Q	■20Q	O

	HSS-E	HSS-E	HSS	HSS	HSS	HSS-E	HSS-E	HSS	HSS-E	HSS-E	
	Z 6-8	Z 6-12	Z 6-12	Z 6-8	Z 6-8	Z 10-12	Z 10-12	Z 4	Z 4-6	Z 16-30	
	DIN 1835B	DIN 1835 D	DIN 1835D	DIN 1835D	DIN 1835D	DIN 1835B	DIN 1835B		DIN 1835B		
	DIN 851	DIN 850	DORMER	DORMER	DORMER	DIN 1833C	DIN 1833D	BS 122/4	DORMER	DIN 885A	
	C801	C822	C820	C837	C835	C830	C831	C710	C700	D200	
	16.00 - 32.00	4.50 - 45.50	10.50 - 45.50	13.00 - 38.00	1/2 - 1.1/2	12.00 - 32.00	12.00 - 32.00	1/16 - 1/2	1.00 - 20.00	50.00 - 125.00	
AMG	475	476	477	479	480	481	482	483	484	485	ISO
1.1	■40P	■40P	■25P	■20P	■20P	■30P	■30P	■20P	■35P	■45P	P 1
1.2	■40P	■40P	■25P	■20P	■20P	■30P	■30P	■20P	■35P	■40P	P 1
1.3	■30O	■30O	■20O	■15O	■15O	■25O	■25O	■15O	■25O	■35P	P 2
1.4	■25O	■25O	■20O	■15O	■15O	■20O	■20O	■15O	■25O	■30P	P 3
1.5	■20N	■20N	●10N	●10N	●10N	■15N	■15N	●10N	■15N	■20P	P 4
1.6	■15N	■15N	●10N	●5N	●5N	■10N	■10N	●10N	■15N	■10P	H 1
1.7											H 3
1.8											H 4
2.1	■25M	■25M	■15M	■10M	■10M	■20M	■20M	■15M	■20M	■30P	M 1
2.2	■15M	■15M	■10M	●10M	●10M	■15M	■15M	■10M	■15M	■20P	M 3
2.3	■15M	■15M	●10M	●5M	●5M	■10M	■10M	●5M	■10M	■10Q	M 2
2.4											S 2
3.1	■25P	■25P	■20P	■15P	■15P	■20P	■20P	■20P	■20P	■30Q	K 1
3.2	■20P	■20P	■20P	■15P	■15P	■15P	■15P	■15P	■15P	■25Q	K 2
3.3	■35O	■30O	■20O	■15O	■15O	■25O	■25O	■15O	■25O	■40Q	K 3
3.4	■20O	■20O	■15O	■10O	■10O	■15O	■15O	■10O	■15O	■25Q	K 4
4.1	■30P	■30P	■20P	■15P	■15P	■25P	■25P	■15P	■25P	■30N	S 1
4.2	■20P	■20P	●15P	●10P	●10P	■15P	■15P	■10P	■20P	■20O	S 2
4.3	■10O	■10O	●10O	●5O	●5O	■10O	■10O	●5O	■10O	■15O	S 3
5.1	■40P	■35P	■25P	■20P	■20P	■30P	■30P	■20P	■35P	■40P	S 1
5.2	■10O	■10O	●5O	●5O	●5O	■10O	■10O	●5O	■10O	■15O	S 2
5.3	■5N	■5N	●5N	●5N	●5N	■5N	■5N	●5N	■5N	■10M	S 3
6.1	■110Q	■100Q	■50Q	■40Q	■40Q	■90Q	■90Q	■40Q	■90Q	■150P	N 3
6.2	■110P	■100P	■55P	■45P	■45P	■90P	■90P	■45P	■90P	■150P	N 4
6.3	■40P	■100P	■55P	■15P	■15P	■75P	■75P	■45P	■90P	■150P	N 3
6.4	■15O	■15O	●5O	●5O	●5O	■10O	■10O	●5O	■15O	■15M	N 4
7.1	■275R	■260R	■65R	■50R	■50R	■190R	■190R	■55R	■245R	■400Q	N 1
7.2	■275R	■260R	■50R	■40R	■40R	■190R	■190R	■40R	■230R	■400Q	N 1
7.3	■70R	■66R	■35R	■25R	■25R	■55R	■55R	■25R	■60R	■100Q	N 1
7.4	■45Q	■44Q	●20Q	●17Q	●17Q	■35Q	■35Q	●15Q	■40Q	■70Q	N 2
8.1	■110R	■100R	●50R	●40R	●40R	■75R	■75R			■150M	O
8.2											O
8.3											O
9.1											H
10.1	■45Q	■45Q	●20Q			■35Q	■35Q	●15Q	■40Q		O

	HSS-E	HSS	HSS	HSS	HSS	HSS	HSS	HSS-E	
	Z 28-44	Z 28-100	Z 40-200	Z 80-180	Z 100-140	Z 128-220	Z 160-350	Z 8-12	N
	$\lambda 15^\circ$ $\gamma 10^\circ$	$\gamma 15^\circ$	$\gamma 5^\circ$	$\gamma 18^\circ$	$\gamma 18^\circ$	$\gamma 18^\circ$	$\gamma 18^\circ$	$\lambda 30^\circ$ $\gamma 12^\circ$	
	js16			ST	ST	ST	ST	js16	
	DIN 885A	DIN 1838	DIN 1837	DORMER	DORMER	DORMER	DORMER	DIN 1880	
	D763	D745	D747	D752	D753	D750	D751	D400	
	63.00 - 125.00	50.00 - 250.00	32.00 - 200.00	250.00 - 350.00	250.00 - 350.00	200.00 - 350.00	200.00 - 350.00	40.00 - 63.00	
AMG	485	486	488	490	490	491	491	492	ISO
1.1	■45P	■40R	■40R	■40R	■40R	■40R	■40R	■40J	P 1
1.2	■40P	■30R	■30R	■30R	■30R	■30R	■30R	■40J	P 1
1.3	■35P	■30R	■30R	■30R	■30R	■30R	■30R	■30I	P 2
1.4	■30P	■20S	■20S	■20S	■20S	■20S	■20S	■25I	P 3
1.5	■20P							●20H	P 4
1.6	■10P							●15H	H 1
1.7									H 3
1.8									H 4
2.1	■30P	●10S	●10S	●10S	●10S	●10S	●10S	■25H	M 1
2.2	■20P	●10S	●10S	●10S	●10S	●10S	●10S	●15G	M 3
2.3	■10Q							■10G	M 2
2.4									S 2
3.1	■30Q	■40R	■40R	■40R	■40R	■40R	■40R	■20J	K 1
3.2	■25Q	■40R	■40R	■40R	■40R	■40R	■40R	■20J	K 2
3.3	■40Q	■30R	■30R	■30R	■30R	■30R	■30R	■30I	K 3
3.4	■25Q							■20I	K 4
4.1	■30N							■30J	S 1
4.2	■20O							●20I	S 2
4.3	■15O							●10I	S 3
5.1	■40P							■35J	S 1
5.2	■15O							●10I	S 2
5.3	■10M							●5H	S 3
6.1	■150P	■200R	■200R	■200R	■200R	■200R	■200R	■105M	N 3
6.2	■150P	■200T	■200T	■200T	■200T	■200T	■200T	■105K	N 4
6.3	■150P	■200T	■200T	■200T	■200T	■200T	■200T	■35K	N 3
6.4	■15M							●15H	N 4
7.1	■400Q	■600T	■600T	■600T	■600T	■600T	■600T	●260N	N 1
7.2	■400Q	■500T	■500T	■500T	■500T	■500T	■500T	■260N	N 1
7.3	■100Q	■500T	■500T	■500T	■500T	■500T	■500T	■65N	N 1
7.4	■70Q							●45L	N 2
8.1	■150M	■60T	■60T	■60T	■60T	■60T	■60T	●105N	O
8.2								●30N	O
8.3								●5L	O
9.1									H
10.1								●45K	O

	HSS-E	HSS-E	HSS-E
	N	NR	NR
	Z 8-12	Z 6-10	Z 6-10
	$\lambda 30^\circ$ $\gamma 12^\circ$	$\lambda 30^\circ$ $\gamma 12^\circ$	$\lambda 30^\circ$ $\gamma 12^\circ$
	js16	js16	js16
	DIN 1880	DIN 1880	DIN 1880
	D420	D402	D422
	40.00 - 63.00	40.00 - 63.00	40.00 - 63.00

AMG	492	493	493	ISO
1.1	■75J	■40J	■75J	P 1
1.2	■75J	■40J	■75J	P 1
1.3	■65I	■30I	■65I	P 2
1.4	■50I	■25I	■50I	P 3
1.5	■35H	●20H	■35H	P 4
1.6	■30H	●15H	■30H	H 1
1.7				H 3
1.8				H 4
2.1	■35H	■25H	■35H	M 1
2.2	■30G	●15G	■30G	M 3
2.3	■20G	■10G	■20G	M 2
2.4				S 2
3.1	■35J	■20J	■35J	K 1
3.2	■30J	■20J	■30J	K 2
3.3	■50I	■30I	■50I	K 3
3.4	■30I	■20I	■30I	K 4
4.1	■35J	■30J	■35J	S 1
4.2	■25I	●20I	■25I	S 2
4.3	■15I	●10I	■15I	S 3
5.1	■75J	■35J	■75J	S 1
5.2	■20I	●10I	■20I	S 2
5.3	■10H	●5H	■10H	S 3
6.1	■150M	■105M	■150M	N 3
6.2	■150K	■105K	■150K	N 4
6.3	■50K	■35K	■50K	N 3
6.4	■20H	●15H	■20H	N 4
7.1	●260N	●260N	●260N	N 1
7.2	■260N	■260N	■260N	N 1
7.3	■135N	■65N	■135N	N 1
7.4	■75L	●45L	■75L	N 2
8.1	■120N	●105N	■120N	O
8.2	●60N	●30N	●60N	O
8.3	●15L	●5L	●15L	O
9.1				H
10.1	■125K	●45K	■125K	O

HM

Z	Z	Z	Z	Z	Ae	Ap	ƒz	∅ [mm]	ƒz [mm/Z] ± 25 %										
1	2	3	4	>4	(x ∅)	(x ∅)													
						A	0.012	0.024	0.035	0.045	0.055	0.065	0.080	0.093	0.107	0.121	0.134	0.149	0.162
						B	0.016	0.032	0.047	0.061	0.074	0.087	0.107	0.124	0.143	0.162	0.179	0.198	0.216
						C	0.020	0.040	0.058	0.076	0.092	0.108	0.134	0.156	0.179	0.202	0.224	0.248	0.271
						D	0.024	0.048	0.070	0.091	0.111	0.130	0.160	0.187	0.214	0.242	0.268	0.297	0.325
						E	0.028	0.056	0.081	0.106	0.129	0.152	0.187	0.218	0.250	0.283	0.313	0.347	0.379
						F	0.032	0.064	0.093	0.121	0.148	0.173	0.214	0.249	0.286	0.323	0.358	0.396	0.433
						G	0.037	0.071	0.105	0.136	0.166	0.195	0.240	0.280	0.321	0.364	0.403	0.446	0.487
						H	0.041	0.079	0.116	0.152	0.185	0.216	0.267	0.311	0.357	0.404	0.447	0.495	0.541
							A	0.010	0.019	0.028	0.036	0.044	0.052	0.064	0.074	0.085	0.096	0.107	0.118
					B		0.013	0.025	0.037	0.048	0.059	0.069	0.085	0.099	0.114	0.128	0.142	0.157	0.172
					C		0.016	0.032	0.046	0.060	0.073	0.086	0.106	0.124	0.142	0.161	0.178	0.197	0.215
					D		0.019	0.038	0.055	0.072	0.088	0.103	0.127	0.148	0.170	0.193	0.213	0.236	0.258
					E		0.023	0.044	0.065	0.084	0.103	0.120	0.149	0.173	0.199	0.225	0.249	0.276	0.301
					F		0.026	0.050	0.074	0.096	0.118	0.138	0.170	0.198	0.227	0.257	0.284	0.315	0.344
					G		0.029	0.057	0.083	0.108	0.132	0.155	0.191	0.223	0.256	0.289	0.320	0.354	0.387
					H		0.032	0.063	0.092	0.120	0.147	0.172	0.212	0.247	0.284	0.321	0.356	0.394	0.430
							A	0.007	0.014	0.021	0.027	0.033	0.038	0.047	0.055	0.063	0.071	0.079	0.087
						B	0.010	0.019	0.027	0.036	0.043	0.051	0.063	0.073	0.084	0.095	0.105	0.116	0.127
						C	0.012	0.023	0.034	0.045	0.054	0.064	0.078	0.091	0.105	0.119	0.132	0.146	0.159
						D	0.014	0.028	0.041	0.053	0.065	0.076	0.094	0.110	0.126	0.143	0.158	0.175	0.191
						E	0.017	0.033	0.048	0.062	0.076	0.089	0.110	0.128	0.147	0.166	0.184	0.204	0.223
						F	0.019	0.037	0.055	0.071	0.087	0.102	0.126	0.146	0.168	0.190	0.210	0.233	0.255
						G	0.021	0.042	0.062	0.080	0.098	0.115	0.141	0.165	0.189	0.214	0.237	0.262	0.286
						H	0.024	0.047	0.068	0.089	0.109	0.127	0.157	0.183	0.210	0.238	0.263	0.291	0.318
							A	0.005	0.010	0.015	0.019	0.024	0.028	0.034	0.040	0.046	0.052	0.058	0.064
					B		0.007	0.014	0.020	0.026	0.032	0.037	0.046	0.053	0.061	0.069	0.077	0.085	0.093
					C		0.009	0.017	0.025	0.032	0.040	0.046	0.057	0.067	0.077	0.087	0.096	0.106	0.116
					D		0.010	0.020	0.030	0.039	0.048	0.056	0.069	0.080	0.092	0.104	0.115	0.127	0.139
					E		0.012	0.024	0.035	0.045	0.055	0.065	0.080	0.093	0.107	0.121	0.134	0.149	0.162
					F		0.014	0.027	0.040	0.052	0.063	0.074	0.092	0.107	0.122	0.138	0.153	0.170	0.185
					G		0.016	0.031	0.045	0.058	0.071	0.083	0.103	0.120	0.138	0.156	0.173	0.191	0.209
					H		0.017	0.034	0.050	0.065	0.079	0.093	0.114	0.133	0.153	0.173	0.192	0.212	0.232
							A	0.004	0.008	0.011	0.015	0.018	0.021	0.026	0.031	0.035	0.040	0.044	0.049
						B	0.005	0.010	0.015	0.020	0.024	0.028	0.035	0.041	0.047	0.053	0.059	0.065	0.071
						C	0.007	0.013	0.019	0.025	0.030	0.035	0.044	0.051	0.058	0.066	0.073	0.081	0.089
						D	0.008	0.016	0.023	0.030	0.036	0.043	0.052	0.061	0.070	0.079	0.088	0.097	0.106
						E	0.009	0.018	0.027	0.035	0.042	0.050	0.061	0.071	0.082	0.093	0.103	0.114	0.124
						F	0.011	0.021	0.030	0.040	0.048	0.057	0.070	0.082	0.094	0.106	0.117	0.130	0.142
						G	0.012	0.023	0.034	0.045	0.054	0.064	0.079	0.092	0.105	0.119	0.132	0.146	0.159
						H	0.013	0.026	0.038	0.050	0.061	0.071	0.087	0.102	0.117	0.132	0.146	0.162	0.177

Raccomandato
 Sehr gut
 Uitstekend
 Excellent

Accettabile
 Gut
 Acceptabel
 Acceptable

HM

Z	Z	Z	Z	Z	A_e (x \emptyset)	A_p (x \emptyset)	f_z	\emptyset [mm]	f_z [mm/Z] $\pm 25\%$													
1	2	3	4	>4				\emptyset	1	2	3	4	5	6	8	10	12	14	16	18	20	
■	■	■							A	0.003	0.006	0.009	0.012	0.014	0.017	0.021	0.024	0.028	0.032	0.035	0.039	0.042
									B	0.004	0.008	0.012	0.016	0.019	0.023	0.028	0.033	0.037	0.042	0.047	0.052	0.057
									C	0.005	0.010	0.015	0.020	0.024	0.028	0.035	0.041	0.047	0.053	0.058	0.065	0.071
									D	0.006	0.012	0.018	0.024	0.029	0.034	0.042	0.049	0.056	0.063	0.070	0.078	0.085
									E	0.007	0.015	0.021	0.028	0.034	0.040	0.049	0.057	0.065	0.074	0.082	0.091	0.099
									F	0.008	0.017	0.024	0.032	0.039	0.045	0.056	0.065	0.075	0.084	0.093	0.103	0.113
									G	0.010	0.019	0.027	0.036	0.043	0.051	0.063	0.073	0.084	0.095	0.105	0.116	0.127
									H	0.011	0.021	0.030	0.040	0.048	0.057	0.070	0.081	0.093	0.106	0.117	0.129	0.141
■	■	■							A	0.003	0.005	0.007	0.010	0.012	0.014	0.017	0.020	0.022	0.025	0.028	0.031	0.034
									B	0.003	0.007	0.010	0.013	0.015	0.018	0.022	0.026	0.030	0.034	0.037	0.041	0.045
									C	0.004	0.008	0.012	0.016	0.019	0.023	0.028	0.033	0.037	0.042	0.047	0.052	0.057
									D	0.005	0.010	0.015	0.019	0.023	0.027	0.033	0.039	0.045	0.051	0.056	0.062	0.068
									E	0.006	0.012	0.017	0.022	0.027	0.032	0.039	0.046	0.052	0.059	0.065	0.072	0.079
									F	0.007	0.013	0.019	0.025	0.031	0.036	0.045	0.052	0.060	0.068	0.075	0.083	0.090
									G	0.008	0.015	0.022	0.029	0.035	0.041	0.050	0.059	0.067	0.076	0.084	0.093	0.102
									H	0.008	0.017	0.024	0.032	0.039	0.045	0.056	0.065	0.075	0.084	0.093	0.103	0.113
■	■								A	0.004	0.008	0.012	0.016	0.020	0.023	0.029	0.033	0.038	0.043	0.048	0.053	0.058
									B	0.006	0.011	0.017	0.022	0.026	0.031	0.038	0.044	0.051	0.058	0.064	0.071	0.077
									C	0.007	0.014	0.021	0.027	0.033	0.039	0.048	0.056	0.064	0.072	0.080	0.088	0.097
									D	0.009	0.017	0.025	0.032	0.040	0.046	0.057	0.067	0.076	0.086	0.096	0.106	0.116
									E	0.010	0.020	0.029	0.038	0.046	0.054	0.067	0.078	0.089	0.101	0.112	0.124	0.135
									F	0.012	0.023	0.033	0.043	0.053	0.062	0.076	0.089	0.102	0.115	0.128	0.141	0.154
									G	0.013	0.025	0.037	0.049	0.059	0.069	0.086	0.100	0.115	0.130	0.144	0.159	0.174
									H	0.014	0.028	0.042	0.054	0.066	0.077	0.095	0.111	0.127	0.144	0.160	0.177	0.193

■ Raccomandato
Sehr gut
Uitstekend
Excellent

● Accettabile
Gut
Acceptabel
Acceptable

HSS HSS-E HSS-E PM

Z 2	Z 3	Z 4	Z >4	Ø	Ae (x Ø)	Ap (x Ø)	fz	Ø [mm] fz [mm/Z] ± 25 %																								
								Ø	1	2	3	4	5	6	8	10	12	14	16	18	20	22	25	28	30	32	36	40	50			
■	●			Ae	Ap	1.0		A	0.004	0.008	0.013	0.017	0.024	0.029	0.043	0.060	0.072	0.084	0.096	0.097	0.096	0.099	0.105	0.109	0.108	0.106	0.108	0.108	0.105			
								B	0.004	0.007	0.012	0.015	0.022	0.026	0.039	0.054	0.065	0.076	0.086	0.087	0.086	0.089	0.095	0.098	0.097	0.095	0.098	0.097	0.095	0.097	0.097	0.095
								C	0.003	0.006	0.011	0.014	0.019	0.023	0.035	0.049	0.058	0.068	0.078	0.079	0.078	0.080	0.085	0.088	0.087	0.086	0.087	0.087	0.086	0.087	0.087	0.085
								D	0.004	0.007	0.011	0.014	0.020	0.024	0.037	0.051	0.061	0.071	0.081	0.082	0.081	0.084	0.089	0.099	0.091	0.097	0.091	0.101	0.101			
								E	0.007	0.012	0.018	0.024	0.035	0.042	0.063	0.087	0.105	0.122	0.140	0.141	0.140	0.144	0.153	0.171	0.157	0.168	0.157	0.175	0.175			
								F	0.007	0.009	0.013	0.018	0.021	0.025	0.033	0.041	0.050	0.055	0.064	0.072	0.079	0.079	0.085	0.085	0.085	0.085	0.085	0.085	0.085	0.085	0.085	0.085
■	■			Ae	Ap	0.05 - 1.0 - 0.15 - 2.0		G					0.026	0.034	0.036	0.043	0.050	0.057	0.064	0.071	0.071	0.054	0.053	0.054	0.053	0.056	0.057	0.060				
								H				0.023	0.031	0.032	0.039	0.045	0.051	0.058	0.064	0.064	0.049	0.048	0.049	0.048	0.048	0.048	0.048	0.050	0.051	0.054		
								I				0.021	0.028	0.029	0.035	0.041	0.046	0.052	0.058	0.058	0.044	0.043	0.044	0.043	0.043	0.043	0.043	0.043	0.045	0.046	0.049	
								J				0.024	0.031	0.033	0.039	0.046	0.052	0.059	0.065	0.065	0.049	0.049	0.049	0.049	0.049	0.049	0.049	0.049	0.051	0.052	0.055	
								K				0.035	0.047	0.065	0.079	0.092	0.105	0.088	0.098	0.097	0.110	0.110	0.110	0.110	0.110	0.110	0.110	0.110	0.110	0.110	0.110	0.110
								L				0.010	0.013	0.017	0.020	0.025	0.028	0.030	0.032	0.033	0.034	0.036	0.038	0.039	0.040	0.042	0.042					
■	■	●		Ae	Ap	0.15 - 1.0 - 0.30 - 1.5		M	0.008	0.012	0.018	0.023	0.031	0.041	0.057	0.069	0.080	0.091	0.103	0.114	0.090	0.103	0.085	0.091	0.097	0.110	0.107	0.086				
								N	0.007	0.011	0.016	0.021	0.028	0.037	0.051	0.062	0.072	0.082	0.093	0.103	0.081	0.093	0.077	0.082	0.087	0.099	0.096	0.077				
								O	0.006	0.010	0.015	0.019	0.025	0.033	0.046	0.056	0.065	0.074	0.083	0.092	0.073	0.083	0.069	0.074	0.079	0.089	0.087	0.070				
								P	0.007	0.010	0.016	0.020	0.027	0.035	0.049	0.059	0.069	0.079	0.088	0.098	0.078	0.088	0.073	0.079	0.084	0.094	0.092	0.074				
								Q	0.009	0.014	0.021	0.026	0.036	0.048	0.066	0.079	0.092	0.106	0.089	0.099	0.098	0.111	0.111	0.119	0.127	0.143	0.139	0.148				
								R	0.012	0.016	0.020	0.025	0.029	0.038	0.047	0.056	0.065	0.073	0.083	0.092	0.092	0.092	0.092	0.092	0.092	0.104	0.104	0.108	0.108			
■			Ae	Ap	0.3 - 0.5 - 0.8 - 1.5		S	0.010	0.015	0.023	0.029	0.039	0.051	0.071	0.086	0.100	0.114	0.129	0.143	0.113	0.129	0.107	0.114	0.122	0.137	0.133	0.107					
							T	0.009	0.014	0.021	0.026	0.035	0.046	0.064	0.077	0.090	0.103	0.116	0.129	0.102	0.116	0.096	0.103	0.110	0.123	0.120	0.096					
							U	0.008	0.012	0.019	0.023	0.032	0.041	0.058	0.070	0.081	0.092	0.104	0.116	0.092	0.104	0.087	0.092	0.099	0.111	0.108	0.087					
							V	0.009	0.013	0.020	0.025	0.033	0.044	0.061	0.074	0.086	0.098	0.110	0.123	0.097	0.110	0.092	0.098	0.105	0.118	0.115	0.092					
							X	0.012	0.017	0.026	0.033	0.045	0.059	0.082	0.099	0.115	0.132	0.111	0.124	0.122	0.139	0.139	0.148	0.158	0.178	0.173	0.186					
							Y	0.015	0.020	0.025	0.031	0.036	0.047	0.059	0.070	0.081	0.092	0.104	0.115	0.115	0.115	0.115	0.115	0.130	0.130	0.136	0.136					

Raccomandato
 Sehr gut
 Uitstekend
 Excellent

Accettabile
 Gut
 Acceptabel
 Acceptable

HSS HSS-E HSS-E PM

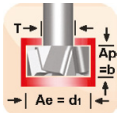
Ø	fz	Ø [mm] fz [mm/Z] ± 25 %														
		10	12	16	20	25	32	38	50	63	80	100	125	160	200	300
C800 C801 C810 C820 C822 C825 	M	0.017	0.022	0.036	0.038	0.041	0.044	0.045	0.047							
	N	0.022	0.027	0.045	0.046	0.052	0.058	0.06	0.062							
	O	0.025	0.03	0.052	0.055	0.056	0.058	0.06	0.062							
	P	0.030	0.043	0.063	0.064	0.062	0.068	0.07	0.072							
	Q	0.045	0.048	0.063	0.064	0.066	0.068	0.07	0.072							
	R	0.055	0.07	0.115	0.119	0.123	0.126	0.128	0.13							

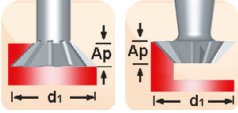
Ø	fz	Ø [mm] fz [mm/Z] ± 25 %														
		10	12	16	20	25	32	38	50	63	80	100	125	160	200	300
C830 C835 C837 C831 	M	0.036	0.045	0.057	0.064	0.074	0.084									
	N	0.048	0.058	0.073	0.084	0.095	0.105									
	O	0.052	0.063	0.081	0.092	0.103	0.114									
	P	0.059	0.071	0.089	0.1	0.112	0.125									
	Q	0.072	0.088	0.106	0.12	0.133	0.147									
	R	0.079	0.095	0.114	0.13	0.143	0.157									

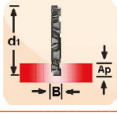

Ø	fz	Ø [mm] fz [mm/Z] ± 25 %														
		10	12	16	20	25	32	38	50	63	80	100	125	160	200	300
C700 C710 	M	0.03	0.03	0.03	0.04	0.05	0.05									
	N	0.04	0.04	0.04	0.05	0.06	0.07									
	O	0.04	0.04	0.05	0.06	0.07	0.08									
	P	0.04	0.04	0.05	0.07	0.08	0.08									
	Q	0.05	0.05	0.07	0.08	0.09	0.10									
	R	0.06	0.06	0.07	0.09	0.10	0.11									

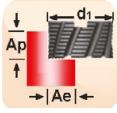

Ø	fz	Ø [mm] fz [mm/Z] ± 25 %														
		10	12	16	20	25	32	38	50	63	80	100	125	160	200	300
D745 D747 D750 D751 D752 D753 	R					0.040	0.040	0.040	0.040	0.040	0.040	0.040	0.040	0.040	0.040	0.040
	S					0.020	0.020	0.020	0.020	0.020	0.020	0.020	0.020	0.020	0.020	0.020
	T					0.060	0.060	0.060	0.060	0.060	0.060	0.060	0.060	0.060	0.060	0.060

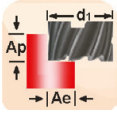
Ø	fz	Ø [mm] fz [mm/Z] ± 25 %														
		10	12	16	20	25	32	38	50	63	80	100	125	160	200	300
D200 D763 	M							0.040	0.050	0.060	0.070	0.080	0.090	0.100		
	N							0.060	0.070	0.080	0.090	0.100	0.105	0.115		
	O							0.070	0.080	0.090	0.100	0.105	0.110	0.120		
	P							0.080	0.090	0.095	0.110	0.115	0.115	0.125		
	Q							0.090	0.100	0.105	0.110	0.115	0.125	0.135		

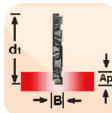
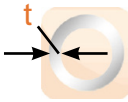
Ø	fz	Ø [mm] fz [mm/Z] ± 25 %														
		40	50	60	80	100	125									
D402 D422 	G	0.042	0.049	0.040	0.047	0.040	0.037									
	H	0.050	0.059	0.047	0.055	0.048	0.044									
	I	0.062	0.071	0.058	0.066	0.058	0.054									
	J	0.082	0.095	0.078	0.090	0.078	0.073									
	K	0.118	0.140	0.110	0.130	0.110	0.103									
	L	0.145	0.171	0.136	0.160	0.136	0.127									
	M	0.185	0.160	0.170	0.200	0.170	0.160									
	N	0.270	0.320	0.250	0.290	0.250	0.230									

Ø	fz	Ø [mm] fz [mm/Z] ± 25 %														
		40	50	60	80	100										
D400 D420 	G	0.042	0.049	0.040	0.047	0.040										
	H	0.050	0.059	0.047	0.055	0.048										
	I	0.062	0.071	0.058	0.066	0.058										
	J	0.082	0.095	0.078	0.090	0.078										
	K	0.118	0.140	0.110	0.130	0.110										
	L	0.145	0.171	0.136	0.160	0.136										
	M	0.185	0.160	0.170	0.200	0.170										
	N	0.270	0.320	0.250	0.290	0.250										

 D750 D751 D752 D753	Tabella tecnica per la scelta del passo tagliente Auswahltable für korrekte Zähnezahl / (P) Aanbevolen aantal tanden (TPI) Choix du pas (nombre de dents)									
	 t (mm)						 Ø (mm)			
	<1.0 mm	1.0 - 1.5 mm	1.5 - 2.0 mm	2.0 - 3.0 mm	3.0 - 4.0 mm	>4.0 mm	10 - 20 mm	20 - 40 mm	40 - 60 mm	
1.1	3	4	5	5	6	7	5	8		P 1
1.2	3	4	4	5	6	7	5	6		P 1
1.3	3	4	4	5	6	7	5	6		P 2
1.4	3	4	4	5	6	7	5	6		P 3
1.5	3	3	4	5	5	6	5	6	8	P 4
1.6										H 1
1.7										H 3
1.8										H 4
2.1	3	4	5	5	6	6	5	6	8	M 1
2.2	3	4	5	5	6	6	5	6	8	M 3
2.3	3	4	5	5	6	6	5	6	8	M 2
2.4	3	4	5	5	6	6	5	6	8	S 2
3.1							6	8		K 1
3.2							6	8		K 2
3.3							6	8		K 3
3.4							6	8		K 4
4.1										S 1
4.2										S 2
4.3										S 3
5.1										S 1
5.2										S 2
5.3										S 3
6.1	4	5	6	7	8	8	6	8		N 3
6.2	4	5	6	7	8	8	8			N 4
6.3	4	5	6	7	8	8	8			N 3
6.4	4	5	6	7	8	8	6	8		N 4
7.1	4	5	6	7	8	8	6	8		N 1
7.2	4	5	6	7	8	8	6	8		N 1
7.3	4	5	6	7	8	8	6	8		N 1
7.4	4	5	6	7	8	8	6	8		N 2
8.1										O
8.2										O
8.3										O
9.1										H
10.1										O

 Tubolare / Profilato Rohre Buis / profielmateriaal tube creux	 Sezione Piena Vollmaterial Stafmateriaal tube plein
--	--

S802HA • Frese per cave
• Langlochfräser

S802HB • Spiebaanfrees
• Fraises à rainurer

S802HA; S802HB	▪	1.1	1.2	1.3	1.4	1.5	1.6	2.1	2.2	3.1	3.2	3.3	3.4	6.2	6.3	6.4	7.2	7.3	7.4
	•	2.3	2.4	4.1	4.2	5.1	5.2	6.1	7.1	8.1	8.2								

S802HA	HM		N	Z 2		λ 28° γ 9°	DIN 6535HA				DIN 6527K
S802HB	HM		N	Z 2		λ 28° γ 9°	DIN 6535HB				DIN 6527K

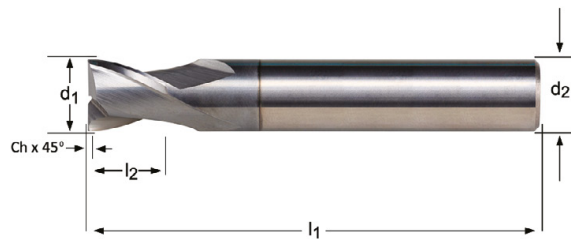

d ₁ Ø mm	Ch ±0.03x45° mm	d ₂ Øh ₆ mm	l ₂ mm	l ₁ mm	z	S802HA	S802HB
1.00	-	3	3	38	2	S802HA1.0	
1.50	-	3	3	38	2	S802HA1.5	
2.00	-	6	3	50	2	S802HA2.0	S802HB2.0
2.50	0.08	6	3	50	2	S802HA2.5	S802HB2.5
3.00	0.08	6	4	50	2	S802HA3.0	S802HB3.0
3.50	0.08	6	4	50	2	S802HA3.5	S802HB3.5
4.00	0.13	6	5	54	2	S802HA4.0	S802HB4.0
4.50	0.13	6	5	54	2	S802HA4.5	S802HB4.5
5.00	0.13	6	6	54	2	S802HA5.0	S802HB5.0
6.00	0.13	6	7	54	2	S802HA6.0	S802HB6.0
7.00	0.13	8	8	58	2	S802HA7.0	S802HB7.0
8.00	0.20	8	9	58	2	S802HA8.0	S802HB8.0 ¹⁾
9.00	0.20	10	10	66	2	S802HA9.0	S802HB9.0 ¹⁾
10.00	0.20	10	11	66	2	S802HA10.0	S802HB10.0 ¹⁾
12.00	0.20	12	12	73	2	S802HA12.0	S802HB12.0 ¹⁾
14.00	0.20	14	14	75	2	S802HA14.0	S802HB14.0 ¹⁾
16.00	0.20	16	16	82	2	S802HA16.0	S802HB16.0 ¹⁾
18.00	0.20	18	18	84	2	S802HA18.0	S802HB18.0 ¹⁾
20.00	0.30	20	20	92	2	S802HA20.0	S802HB20.0 ¹⁾

S812HA • Frese per cave
• Langlochfräser

S812HB • Spiebaanfrees
• Fraises à rainurer

S812HA; S812HB	1.1	1.2	1.3	1.4	1.5	1.6	2.1	2.2	2.3	3.1	3.2	3.3	3.4	4.1	4.2	5.1	5.2
	6.1	6.2	6.3	6.4	7.1	7.2	7.3	7.4	8.1	8.2							

S812HA	HM		N	Z 2		λ 28° γ 9°	DIN 6535HA				DIN 6527L
S812HB	HM		N	Z 2		λ 28° γ 9°	DIN 6535HB				DIN 6527L

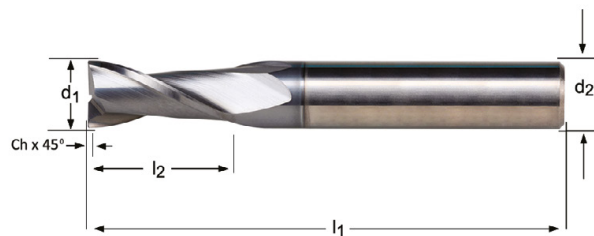



d ₁ Ø mm	Ch ±0.03x45° mm	d ₂ Øh ₈ mm	l ₂ mm	l ₁ mm	z	S812HA	S812HB
2.00	-	6	6	57	2	S812HA2.0	S812HB2.0
2.50	0.08	6	7	57	2	S812HA2.5	S812HB2.5
3.00	0.08	6	7	57	2	S812HA3.0	S812HB3.0
3.50	0.08	6	7	57	2	S812HA3.5	S812HB3.5
4.00	0.13	6	8	57	2	S812HA4.0	S812HB4.0
4.50	0.13	6	8	57	2	S812HA4.5	S812HB4.5
5.00	0.13	6	10	57	2	S812HA5.0	S812HB5.0
6.00	0.13	6	10	57	2	S812HA6.0	S812HB6.0
7.00	0.13	8	13	63	2	S812HA7.0	S812HB7.0
8.00	0.20	8	16	63	2	S812HA8.0	S812HB8.0 ¹⁾
9.00	0.20	10	16	72	2	S812HA9.0	S812HB9.0 ¹⁾
10.00	0.20	10	19	72	2	S812HA10.0	S812HB10.0 ¹⁾
12.00	0.20	12	22	83	2	S812HA12.0	S812HB12.0 ¹⁾
14.00	0.20	14	22	83	2	S812HA14.0	S812HB14.0 ¹⁾
16.00	0.20	16	26	92	2	S812HA16.0	S812HB16.0 ¹⁾
18.00	0.20	18	26	92	2	S812HA18.0	S812HB18.0 ¹⁾
20.00	0.30	20	32	104	2	S812HA20.0	S812HB20.0 ¹⁾

¹⁾ Ch ± 0.05x45° mm

S822

- Frese per cave
- Langlochfräser
- Spiebaanfrees
- Fraises à rainurer

S822	1.1	1.2	1.3	1.4	1.5	1.6	2.1	2.2	2.3	3.1	3.2	3.3	3.4	4.1	4.2	5.1	5.2	6.1	6.2	6.3
	6.4	7.1	7.2	7.3	7.4	8.1	8.2													

S822 **HM** **P9** **N** **Z 2**  $\lambda 28^\circ$ $\gamma 9^\circ$ **DIN 6535HA** **Alcrona** 

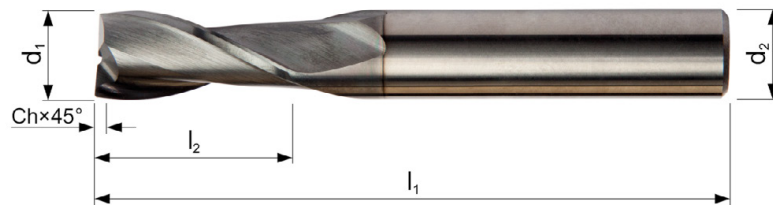

d_1 \varnothing mm	Ch $\pm 0.03 \times 45^\circ$ mm	d_2 $\varnothing h_6$ mm	l_2 mm	l_1 mm	z	S822
2.00	-	6	8	57	2	S8222.0
2.50	0.08	6	12	57	2	S8222.5
3.00	0.08	6	12	57	2	S8223.0
4.00	0.13	6	14	57	2	S8224.0
5.00	0.13	6	16	57	2	S8225.0
6.00	0.13	6	19	57	2	S8226.0
7.00	0.13	8	19	63	2	S8227.0
8.00	0.20	8	19	63	2	S8228.0 ¹⁾
9.00	0.20	10	21	72	2	S8229.0 ¹⁾
10.00	0.20	10	22	72	2	S82210.0 ¹⁾
12.00	0.20	12	25	83	2	S82212.0 ¹⁾
14.00	0.20	14	30	83	2	S82214.0 ¹⁾
16.00	0.20	16	32	92	2	S82216.0 ¹⁾
18.00	0.20	18	32	92	2	S82218.0 ¹⁾
20.00	0.30	20	38	104	2	S82220.0 ¹⁾

¹⁾ Ch $\pm 0.05 \times 45^\circ$ mm
392

S803HA • Frese per cave
• Langlochfräser

S803HB • Spiebaanfrees
• Fraises à rainurer

S803HA; S803HB	▪	1.1	1.2	1.3	1.4	1.5	1.6	2.1	2.2	3.1	3.2	3.3	3.4	6.2	6.3	6.4	7.2	7.3	7.4
	•	2.3	2.4	4.1	4.2	5.1	5.2	6.1	7.1	8.1	8.2								

S803HA	HM		N	Z 3		λ 28° γ 9°	DIN 6535HA	Alcrona			DIN 6527K
S803HB	HM		N	Z 3		λ 28° γ 9°	DIN 6535HB	Alcrona			DIN 6527K

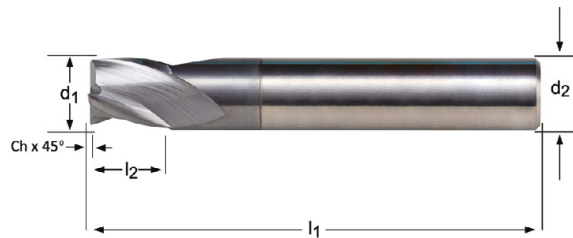

d ₁ Ø mm	Ch ±0.03x45° mm	d ₂ Ø _{h6} mm	l ₂ mm	l ₁ mm	z	S803HA	S803HB
1.00	-	3	3	38	3	S803HA1.0	
1.50	-	3	3	38	3	S803HA1.5	
2.00	-	6	3	50	3	S803HA2.0	S803HB2.0
2.50	0.08	6	3	50	3	S803HA2.5	S803HB2.5
2.80	0.08	6	4	50	3	S803HA2.8	S803HB2.8
3.00	0.08	6	4	50	3	S803HA3.0	S803HB3.0
3.50	0.08	6	4	50	3	S803HA3.5	S803HB3.5
3.80	0.08	6	5	54	3	S803HA3.8	S803HB3.8
4.00	0.13	6	5	54	3	S803HA4.0	S803HB4.0
4.50	0.13	6	5	54	3	S803HA4.5	S803HB4.5
4.80	0.13	6	6	54	3	S803HA4.8	S803HB4.8
5.00	0.13	6	6	54	3	S803HA5.0	S803HB5.0
5.75	0.13	6	7	54	3		S803HB5.75
6.00	0.13	6	7	54	3	S803HA6.0	S803HB6.0
6.75	0.13	8	8	58	3		S803HB6.75
7.00	0.13	8	8	58	3	S803HA7.0	S803HB7.0
7.75	0.13	8	9	58	3		S803HB7.75
8.00	0.20	8	9	58	3	S803HA8.0	¹⁾ S803HB8.0
9.00	0.20	10	10	66	3	S803HA9.0	¹⁾ S803HB9.0
9.70	0.20	10	11	66	3		¹⁾ S803HB9.7
10.00	0.20	10	11	66	3	S803HA10.0	¹⁾ S803HB10.0
11.70	0.20	12	12	73	3		¹⁾ S803HB11.7
12.00	0.20	12	12	73	3	S803HA12.0	¹⁾ S803HB12.0
14.00	0.20	14	14	75	3	S803HA14.0	¹⁾ S803HB14.0
16.00	0.20	16	16	82	3	S803HA16.0	¹⁾ S803HB16.0
18.00	0.20	18	18	84	3	S803HA18.0	¹⁾ S803HB18.0
20.00	0.30	20	20	92	3	S803HA20.0	¹⁾ S803HB20.0

¹⁾ Ch ± 0.05x45° mm

S813HA • Frese per cave
• Langlochfräser

S813HB • Spiebaanfrees
• Fraises à rainurer

S813HA; S813HB	▪	1.1	1.2	1.3	1.4	1.5	2.1	3.1	3.2	3.3	3.4	6.2	6.3	6.4	7.2	7.3	7.4
	•	1.6	2.2	2.3	4.1	4.2	5.1	5.2	6.1	7.1	8.1	8.2					

S813HA	HM		N	Z 3		λ 28° γ 9°	DIN 6535HA	Alcrona			DIN 6527L
S813HB	HM		N	Z 3		λ 28° γ 9°	DIN 6535HB	Alcrona			DIN 6527L

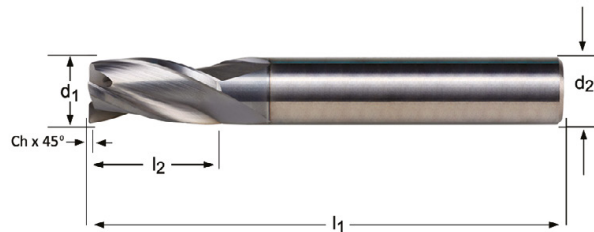

d_1 Ø mm	Ch $\pm 0.03 \times 45^\circ$ mm	d_2 Øh ₆ mm	l_2 mm	l_1 mm	z	S813HA	S813HB
2.00	0.00	6	6	57	3	S813HA2.0	S813HB2.0
2.50	0.08	6	7	57	3	S813HA2.5	S813HB2.5
3.00	0.08	6	7	57	3	S813HA3.0	S813HB3.0
3.50	0.08	6	7	57	3	S813HA3.5	S813HB3.5
4.00	0.13	6	8	57	3	S813HA4.0	S813HB4.0
4.50	0.13	6	8	57	3	S813HA4.5	S813HB4.5
5.00	0.13	6	10	57	3	S813HA5.0	S813HB5.0
6.00	0.13	6	10	57	3	S813HA6.0	S813HB6.0
7.00	0.13	8	13	63	3	S813HA7.0	S813HB7.0
8.00	0.20	8	16	63	3	S813HA8.0	¹⁾ S813HB8.0
9.00	0.20	10	16	72	3	S813HA9.0	¹⁾ S813HB9.0
10.00	0.20	10	19	72	3	S813HA10.0	¹⁾ S813HB10.0
12.00	0.20	12	22	83	3	S813HA12.0	¹⁾ S813HB12.0
14.00	0.20	14	22	83	3	S813HA14.0	¹⁾ S813HB14.0
16.00	0.20	16	26	92	3	S813HA16.0	¹⁾ S813HB16.0
18.00	0.20	18	26	92	3	S813HA18.0	¹⁾ S813HB18.0
20.00	0.30	20	32	104	3	S813HA20.0	¹⁾ S813HB20.0

S823

- Frese per cave
- Langlochfräser
- Spiebaanfrees
- Fraises à rainurer

S823	▪	1.1	1.2	1.3	1.4	1.5	2.1	3.1	3.2	3.3	3.4	6.2	6.3	6.4	7.2	7.3	7.4	
	•	1.6	2.2	2.3	4.1	4.2	5.1	5.2	6.1	7.1	8.1	8.2						

S823 **HM** **N** **Z 3** $\lambda 28^\circ$ $\gamma 9^\circ$ **DIN 6535HA**

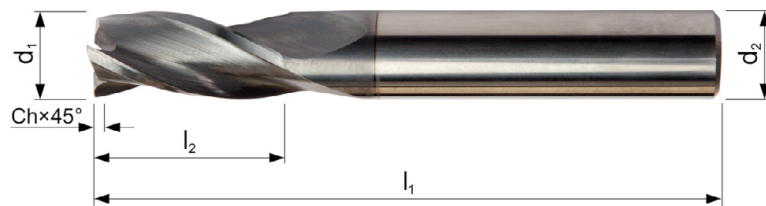

d_1 \varnothing mm	Ch $\pm 0.03 \times 45^\circ$ mm	d_2 $\varnothing h_6$ mm	l_2 mm	l_1 mm	z	S823
2.00	-	6	8	57	3	S8232.0
2.50	0.08	6	12	57	3	S8232.5
3.00	0.08	6	12	57	3	S8233.0
4.00	0.13	6	14	57	3	S8234.0
5.00	0.13	6	16	57	3	S8235.0
6.00	0.13	6	19	57	3	S8236.0
7.00	0.13	8	19	63	3	S8237.0
8.00	0.20	8	19	63	3	S8238.0 ¹⁾
9.00	0.20	10	21	72	3	S8239.0 ¹⁾
10.00	0.20	10	22	72	3	S82310.0 ¹⁾
12.00	0.20	12	25	83	3	S82312.0 ¹⁾
14.00	0.20	14	30	83	3	S82314.0 ¹⁾
16.00	0.20	16	32	92	3	S82316.0 ¹⁾
18.00	0.20	18	32	92	3	S82318.0 ¹⁾
20.00	0.30	20	38	104	3	S82320.0 ¹⁾

¹⁾ Ch $\pm 0.05 \times 45^\circ$ mm

S710

- Frese
- Schafffräser
- Spiebaanfrees
- Fraises de finition

S710 ■ 1.1 1.2 1.3 1.4 1.5 2.1 2.2 3.1 3.2 3.3 3.4 4.2 5.2

S710 **HM**  **N** **Z 2**  **λ 40°**
γ 10° **DIN 6535HA**  **h9**  **DORMER**

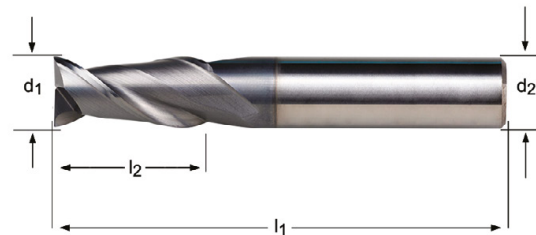

S710



1.00 - 20.00

d_1 Ø mm	d_2 Ø _{h₆} mm	l_2 mm	l_1 mm	z	S710
1.00	3	3	40	2	S7101.0
1.50	3	4.5	40	2	S7101.5
2.00	3	6.5	40	2	S7102.0
2.50	3	6.5	40	2	S7102.5
3.00	6	9	50	2	S7103.0
4.00	6	12	50	2	S7104.0
5.00	6	15	50	2	S7105.0
6.00	6	20	60	2	S7106.0
8.00	8	20	64	2	S7108.0
10.00	10	22	75	2	S71010.0
12.00	12	25	75	2	S71012.0
16.00	16	32	90	2	S71016.0
20.00	20	38	100	2	S71020.0

- S902** • Frese
• Schafffräser
- S922** • Spiebaanfrees
• Fraises de finition

S902	▪	1.1	1.2	1.3	1.4	3.1	3.3	4.1	5.1	6.1	6.2	6.3			
	•	1.5	3.2	3.4	4.2	4.3	6.4	7.1	7.2	7.3	8.1	8.2	8.3		
S922	▪	1.1	1.2	1.3	1.4	1.5	3.1	3.2	3.3	3.4	4.1	5.1	6.1	6.2	6.3
	•	1.6	4.2	4.3	6.4	7.1	7.2	7.3	8.1	8.2	8.3				

S902	HM		N	Z 2		$\lambda 30^\circ$ $\gamma 12^\circ$	DIN 6535HA		h10				
S922	HM		N	Z 2		$\lambda 30^\circ$ $\gamma 12^\circ$	DIN 6535HB	TiAIN	h10				437

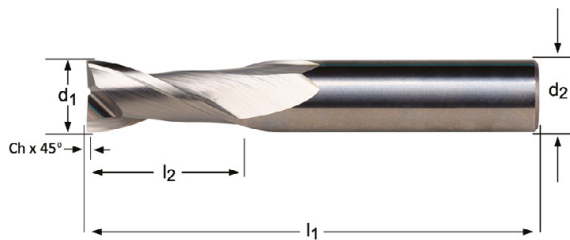

d ₁ Ø mm	Ch ±0.03x45° mm	d ₂ Øh ₆ mm	l ₂ mm	l ₁ mm	z	S902	S922
2.00	0.08	3	6	38	2	S9022.0	S9222.0 ²⁾
2.50	0.08	3	9	38	2	S9022.5	S9222.5 ²⁾
3.00	0.08	3	12	38	2	S9023.0	S9223.0 ²⁾
4.00	0.08	4	14	50	2	S9024.0	S9224.0 ²⁾
5.00	0.13	5	16	50	2	S9025.0	S9225.0 ²⁾
6.00	0.13	6	19	57	2	S9026.0	S9226.0
7.00	0.13	8	19	63	2	S9027.0	S9227.0
8.00	0.13	8	19	63	2	S9028.0	S9228.0
9.00	0.13	10	21	72	2	S9029.0	S9229.0
10.00	0.18	10	22	72	2	S90210.0	S92210.0
12.00	0.20	12	25	73	2	S90212.0 ¹⁾	S92212.0 ¹⁾
14.00	0.20	14	30	83	2	S90214.0 ¹⁾	S92214.0 ¹⁾
16.00	0.20	16	32	92	2	S90216.0 ¹⁾	S92216.0 ¹⁾
18.00	0.20	18	32	92	2	S90218.0 ¹⁾	S92218.0 ¹⁾
20.00	0.30	20	38	104	2	S90220.0 ¹⁾	S92220.0 ¹⁾



¹⁾ Ch ± 0.05x45° mm

²⁾ Codolo liscio / Zylinderschaft / Cilindrische schacht / queue cylindrique

S713

- Frese
- Schafffräser
- Spiebaanfrees
- Fraises de finition

S713 ■ 1.1 1.2 1.3 1.4 1.5 2.1 2.2 3.1 3.2 3.3 3.4 4.2 5.2

S713 **HM**  **N** **Z 3**  **λ 40°**
γ 10° **DIN 6535HA**  **h9** 

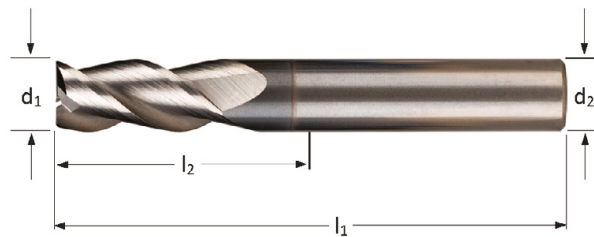

d_1 ∅ mm	d_2 ∅ _{h6} mm	l_2 mm	l_1 mm	z	S713
1.50	4	4.5	40	3	S7131.5
2.00	4	6.5	40	3	S7132.0
3.00	3	9	40	3	S7133.0
4.00	4	12	50	3	S7134.0
5.00	5	15	50	3	S7135.0
6.00	6	16	50	3	S7136.0
8.00	8	20	64	3	S7138.0
10.00	10	22	70	3	S71310.0
12.00	12	25	75	3	S71312.0
14.00	14	32	90	3	S71314.0
16.00	16	32	90	3	S71316.0
18.00	18	38	100	3	S71318.0
20.00	20	38	100	3	S71320.0

- S903** • Frese
• Schafffräser
- S933** • Spiebaanfrees
• Fraises de finition

S903	▪	1.1	1.2	1.3	1.4	3.1	3.3	4.1	5.1	6.1	6.2	6.3			
	•	1.5	3.2	3.4	4.2	4.3	6.4	7.1	7.2	7.3	8.1	8.2	8.3		
S933	▪	1.1	1.2	1.3	1.4	1.5	3.1	3.2	3.3	3.4	4.1	5.1	6.1	6.2	6.3
	•	1.6	4.2	4.3	6.4	7.1	7.2	7.3	8.1	8.2	8.3				

S903	HM		N	Z 3		$\lambda 30^\circ$ $\gamma 12^\circ$	DIN 6535HA		h10		DORMER	
S933	HM		N	Z 3		$\lambda 30^\circ$ $\gamma 12^\circ$	DIN 6535HB	TiAlN	h10		DORMER	S991 437

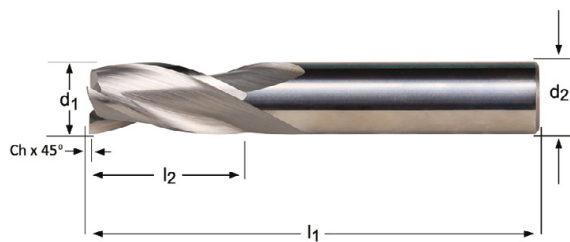

d ₁ Ø mm	Ch ±0.03x45° mm	d ₂ Øh ₆ mm	l ₂ mm	l ₁ mm	z	S903	S933
2.00	0.08	3	6	38	3	S9032.0	S9332.0 ²⁾
2.50	0.08	3	9	38	3	S9032.5	S9332.5 ²⁾
3.00	0.08	3	12	38	3	S9033.0	S9333.0 ²⁾
4.00	0.08	4	14	50	3	S9034.0	S9334.0 ²⁾
5.00	0.13	5	16	50	3	S9035.0	S9335.0 ²⁾
6.00	0.13	6	19	57	3	S9036.0	S9336.0
7.00	0.13	8	19	63	3	S9037.0	S9337.0
8.00	0.13	8	19	63	3	S9038.0	S9338.0
9.00	0.13	10	21	72	3	S9039.0	S9339.0
10.00	0.20	10	22	72	3	S90310.0	S93310.0 ¹⁾
12.00	0.20	12	25	73	3	S90312.0	S93312.0 ¹⁾
14.00	0.20	14	30	83	3	S90314.0	S93314.0 ¹⁾
16.00	0.20	16	32	92	3	S90316.0	S93316.0 ¹⁾
18.00	0.20	18	32	92	3	S90318.0	S93318.0 ¹⁾
20.00	0.30	20	38	104	3	S90320.0	S93320.0 ¹⁾





¹⁾ Ch ± 0.05x45° mm

²⁾ Codolo liscio / Zylinderschaft / Cilindrische schacht / queue cylindrique

S714

- Frese
- Schafffräser
- Vingerfrees
- Fraises de finition

S714	▪	1.1	1.2	1.3	1.4	1.5	2.1	2.2	3.1	3.2	3.3	3.4	4.2	5.2
	•	6.1	6.2	6.3	6.4	7.1	7.2	7.3	7.4					

S714 **HM**  **N** **Z 3**  **λ 40°**
γ 10° **DIN 6535HA**  **h9** 

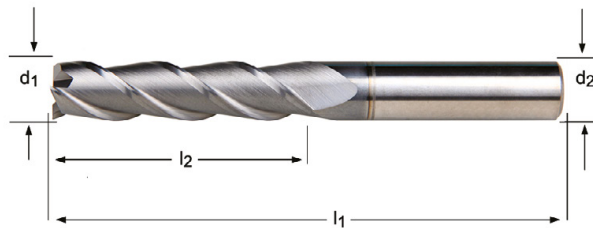

d_1 Ø mm	d_2 Ø _{h6} mm	l_2 mm	l_1 mm	z	S714
3.00	3	19	60	3	S7143.0
4.00	4	19	60	3	S7144.0
5.00	5	19	60	3	S7145.0
6.00	6	31	75	3	S7146.0
8.00	8	31	75	3	S7148.0
10.00	10	31	75	3	S71410.0
12.00	12	50	100	3	S71412.0
14.00	14	57	125	3	S71414.0
16.00	16	57	125	3	S71416.0
18.00	18	57	125	3	S71418.0
20.00	20	57	125	3	S71420.0

S715

- Frese
- Schafffräser
- Vingerfrees
- Fraises de finition

S715	▪	1.1	1.2	1.3	1.4	1.5	2.1	2.2	3.1	3.2	3.3	3.4	4.2	5.2
	•	6.1	6.2	6.3	6.4	7.1	7.2	7.3	7.4					

S715 **HM** **N** **Z 3** **λ 40°** **γ 10°** **DIN 6535HA** **AICrN** **h9**

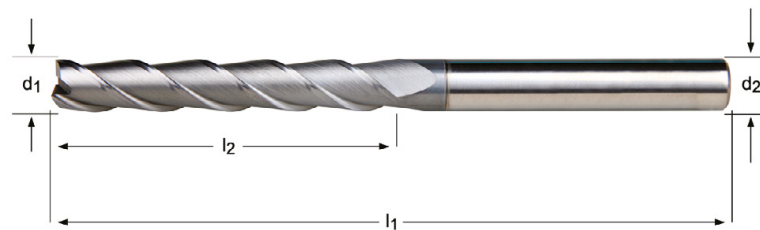

d_1 Ø mm	d_2 Ø _{h6} mm	l_2 mm	l_1 mm	z	S715
3.00	3	25	100	3	S7153.0
4.00	4	31	100	3	S7154.0
5.00	5	31	100	3	S7155.0
6.00	6	38	100	3	S7156.0
8.00	8	41	100	3	S7158.0
10.00	10	57	125	3	S71510.0
12.00	12	75	150	3	S71512.0
14.00	14	75	150	3	S71514.0
16.00	16	75	150	3	S71516.0
18.00	18	75	150	3	S71518.0
20.00	20	75	150	3	S71520.0

S637

- Frese
- Schafffräser
- Eénsnijder
- Fraises de finition

S637 ■ 6.1 6.2 6.3 6.4 7.1 7.2 7.3 7.4 8.1 8.2

S637 **HM**  **W** **Z 1**  **λ 25°**
γ 20° **DIN 6535HA**  **h9**  **DORMER**

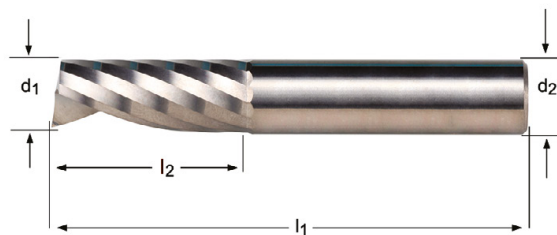

S637



2.00 - 12.00

d_1 Ø mm	d_2 Ø _{h₆} mm	l_2 mm	l_1 mm	z	S637
2.00	2	10	40	1	S6372.0
3.00	3	12	40	1	S6373.0
4.00	4	15	50	1	S6374.0
5.00	5	16	50	1	S6375.0
6.00	6	20	60	1	S6376.0
8.00	8	22	63	1	S6378.0
10.00	10	25	72	1	S63710.0
12.00	12	30	83	1	S63712.0

S638

- Frese
- Schafffräser
- Spiebaanfrees
- Fraises de finition

Codolo ridotto
 Reduzierter Schaft
 Verjongde schacht
 Queue réduite

S638 ■ 6.1 6.2 6.3 6.4 7.1 7.2 7.3 7.4 8.1 8.2

S638 **HM** **W** **Z 2** **$\lambda 30^\circ$**
 $\gamma 20^\circ$ **Hi** **h9** **DORMER**

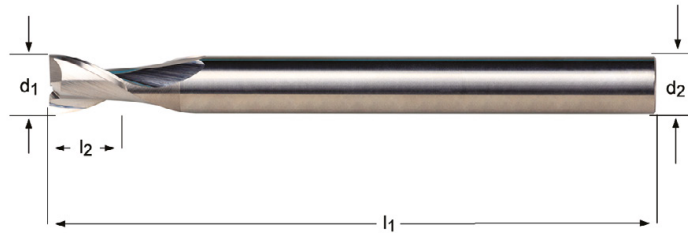

d_1 \varnothing mm	r ± 0.02 mm	d_2 $\varnothing h_6$ mm	l_2 mm	l_1 mm	z	S638
6.20	0.10	6	8	100	2	S6386.2
8.20	0.10	8	10	100	2	S6388.2
10.30	0.10	10	14	125	2	S63810.3
12.30	0.10	12	16	125	2	S63812.3
16.30	0.10	16	20	125	2	S63816.3
20.30	0.10	20	25	125	2	S63820.3

S610

- Frese
- Schafffräser
- Vingerfrees
- Fraises de finition

S610 ■ 6.1 6.2 6.3 6.4 7.1 7.2 7.3 7.4 8.1 8.2

S610 **HM**  **W** **Z 2**  **λ 30°**
γ 20° **DIN 6535HA**  **h9**  **DORMER**



d_1 Ø mm	r ±0.02 mm	d_2 Ø _{h6} mm	l_2 mm	l_1 mm	z	S610
3.00	0.10	3	9	40	2	S6103.0XD3
3.00	0.10	6	9	50	2	S6103.0XD6
4.00	0.10	4	12	50	2	S6104.0XD4
4.00	0.10	6	12	50	2	S6104.0XD6
5.00	0.10	6	15	50	2	S6105.0
6.00	0.10	6	20	50	2	S6106.0
8.00	0.10	8	20	64	2	S6108.0
10.00	0.10	10	22	75	2	S61010.0
12.00	0.10	12	25	75	2	S61012.0
14.00	0.10	14	32	90	2	S61014.0
16.00	0.10	16	32	90	2	S61016.0
20.00	0.10	20	38	100	2	S61020.0

S611

- Frese
- Schaftfräser
- Vingerfreese
- Fraises de finition

S611 ■ 6.1 6.2 6.3 6.4 7.1 7.2 7.3 7.4 8.1 8.2

S611 **HM** **W** **Z 2** **λ 30°**
γ 20° **Hi** **h9**

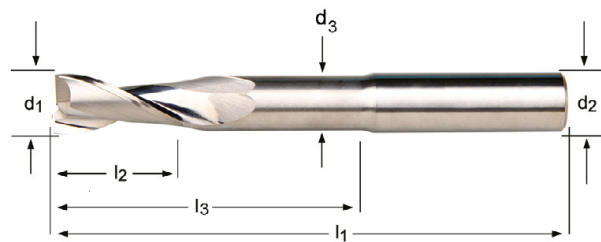

d_1 ∅ mm	r ±0.02 mm	d_2 ∅ _{h6} mm	l_2 mm	l_1 mm	z	l_3 mm	d_3 ∅ mm	S611
6.00	0.10	6	16	80	2	40.0	5.5	S6116.0
8.00	0.10	8	20	80	2	40.0	7.4	S6118.0
10.00	0.10	10	22	100	2	60.0	9.2	S61110.0
12.00	0.10	12	25	100	2	60.0	11.0	S61112.0
14.00	0.10	14	32	125	2	75.0	13.0	S61114.0
16.00	0.10	16	32	125	2	75.0	15.0	S61116.0
20.00	0.10	20	38	125	2	75.0	19.0	S61120.0

S804HA • Frese
• Schafffräser

S804HB • Vingerfrees
• Fraises de finition

S804HA; S804HB	▪	1.1	1.2	1.3	1.4	1.5	1.6	2.1	2.2	3.1	3.2	3.3	3.4	6.2	6.3	6.4
	•	2.3	2.4	4.1	4.2	5.1	5.2	6.1	7.1	7.2	7.3	7.4	8.1	8.2		

S804HA	HM		N	Z 4		λ 34° γ 9°	DIN 6535HA	Alcrona	h10		DIN 6527K
S804HB	HM		N	Z 4		λ 34° γ 9°	DIN 6535HB	Alcrona	h10		DIN 6527K

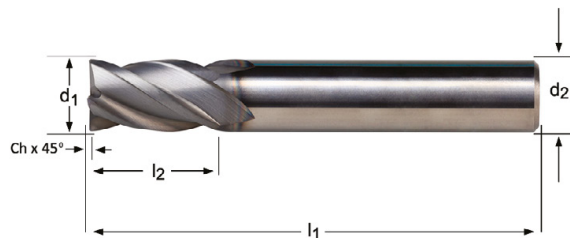

d ₁ Ø mm	Ch ±0.03x45° mm	d ₂ Øh ₆ mm	l ₂ mm	l ₁ mm	z	S804HA	S804HB
2.00	-	6	4	50	4	S804HA2.0	S804HB2.0
3.00	0.08	6	5	50	4	S804HA3.0	S804HB3.0
4.00	0.13	6	8	54	4	S804HA4.0	S804HB4.0
5.00	0.13	6	9	54	4	S804HA5.0	S804HB5.0
6.00	0.13	6	10	54	4	S804HA6.0	S804HB6.0
8.00	0.13	8	12	58	4	S804HA8.0	S804HB8.0
10.00	0.20	10	14	66	4	S804HA10.0	S804HB10.0 ¹⁾
12.00	0.20	12	16	73	4	S804HA12.0	S804HB12.0 ¹⁾
16.00	0.20	16	22	82	4	S804HA16.0	S804HB16.0 ¹⁾
20.00	0.30	20	26	92	4	S804HA20.0	S804HB20.0 ¹⁾
25.00	0.30	25	32	121	4	S804HA25.0	S804HB25.0 ¹⁾

¹⁾ Ch ± 0.05x45° mm
406

S219

- Frese
- Schafffräser
- Vingerfrees
- Fraises de finition

S219 ■ 1.6 2.3 2.4 4.3 5.3

S219 **HM** **N** **Z 4** **$\lambda 40^\circ$** **$\gamma 3^\circ$** **DIN 6535HA** **AITIN** **h9** **DORMER**

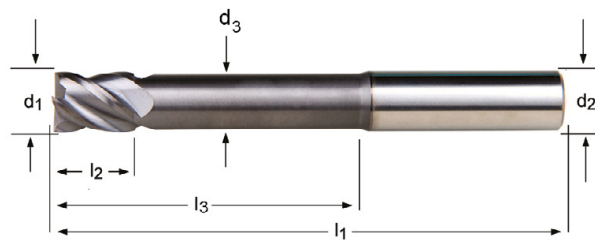

d_1 \varnothing mm	d_2 $\varnothing h_6$ mm	l_2 mm	l_1 mm	z	l_3 mm	d_3 \varnothing mm	S219
3.00	3	5	60	4	30.0	2.8	S2193.0
4.00	4	8	60	4	32.0	3.7	S2194.0
5.00	5	9	60	4	32.0	4.6	S2195.0
6.00	6	10	75	4	40.0	5.5	S2196.0
8.00	8	12	75	4	40.0	7.4	S2198.0
10.00	10	14	75	4	40.0	9.2	S21910.0
12.00	12	16	100	4	60.0	11.0	S21912.0
14.00	14	22	125	4	85.0	13.0	S21914.0
16.00	16	22	125	4	85.0	15.0	S21916.0
18.00	18	26	125	4	85.0	17.0	S21918.0
20.00	20	26	125	4	85.0	19.0	S21920.0

S814HA • Frese
• Schafffräser

S814HB • Vingerfrees
• Fraises de finition

S814HA; S814HB	▪	1.1	1.2	1.3	1.4	1.5	2.1	3.1	3.2	3.3	3.4	6.2	6.3	6.4	
	•	1.6	2.2	2.3	4.1	4.2	5.1	5.2	6.1	7.1	7.2	7.3	7.4	8.1	8.2

S814HA	HM		N	Z 4		λ 34° γ 9°	DIN 6535HA	Alcrona	h10		DIN 6527L
S814HB	HM		N	Z 4		λ 34° γ 9°	DIN 6535HB	Alcrona	h10		DIN 6527L

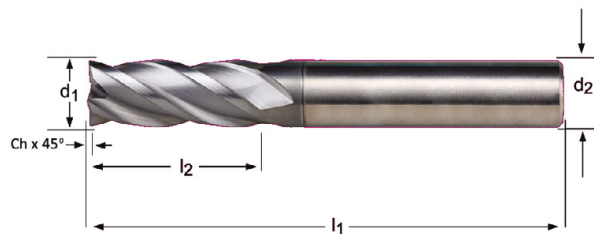

d_1 Ø mm	Ch $\pm 0.03 \times 45^\circ$ mm	d_2 Ø h_6 mm	l_2 mm	l_1 mm	z	S814HA	S814HB
2.00	0.00	6	7	57	4	S814HA2.0	S814HB2.0
3.00	0.08	6	8	57	4	S814HA3.0	S814HB3.0
4.00	0.13	6	11	57	4	S814HA4.0	S814HB4.0
5.00	0.13	6	13	57	4	S814HA5.0	S814HB5.0
6.00	0.13	6	13	57	4	S814HA6.0	S814HB6.0
8.00	0.13	8	19	63	4	S814HA8.0	S814HB8.0
10.00	0.20	10	22	72	4	S814HA10.0	S814HB10.0 ¹⁾
12.00	0.20	12	26	83	4	S814HA12.0	S814HB12.0 ¹⁾
16.00	0.20	16	32	92	4	S814HA16.0	S814HB16.0 ¹⁾
20.00	0.30	20	38	104	4	S814HA20.0	S814HB20.0 ¹⁾
25.00	0.30	25	45	121	4	S814HA25.0	S814HB25.0 ¹⁾

¹⁾ Ch $\pm 0.05 \times 45^\circ$ mm
408

S716

- Frese
- Schafffräser
- Vingerfrees
- Fraises de finition

S716 ■ 1.1 1.2 1.3 1.4 1.5 2.1 2.2 3.1 3.2 3.3 3.4 4.2 5.2

S716 **HM** **N** **Z 4** **λ 40°** **γ 10°** **DIN 6535HA** **AICrN** **h9**

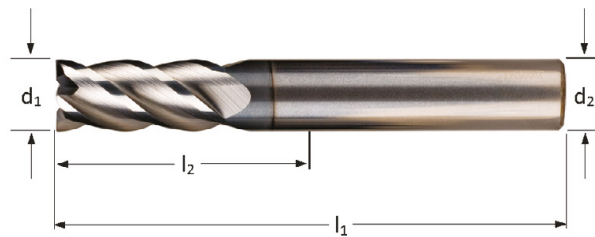

d_1 Ø mm	d_2 Ø _{h6} mm	l_2 mm	l_1 mm	z	S716
2.00	4	6.5	40	4	S7162.0
3.00	3	9	40	4	S7163.0
4.00	4	12	50	4	S7164.0
5.00	5	15	50	4	S7165.0
6.00	6	16	50	4	S7166.0
8.00	8	20	64	4	S7168.0
10.00	10	22	70	4	S71610.0
12.00	12	25	75	4	S71612.0
14.00	14	32	90	4	S71614.0
16.00	16	32	90	4	S71616.0
18.00	18	38	100	4	S71618.0
20.00	20	38	100	4	S71620.0

- S612**
- Frese
 - Schafffräser
 - Vingerfrees
 - Fraises de finition

S612 ■ 10.1

S612 **HM**  **N**  **Z 4**  **λ 40°**
γ 10°  **DIN 6535HA**  **Diamond** **h9**  **DORMER**

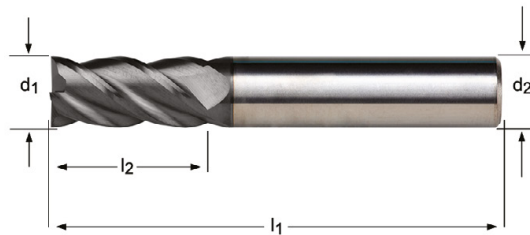

S612



1.00 - 12.00

d_1 Ø mm	d_2 Ø _{h6} mm	l_2 mm	l_1 mm	z	S612
1.00	3	3	50	4	S6121.0
1.50	3	4.5	50	4	S6121.5
2.00	3	6.5	50	4	S6122.0
2.50	3	6.5	50	4	S6122.5
3.00	3	9	50	4	S6123.0
4.00	4	12	50	4	S6124.0
5.00	5	15	50	4	S6125.0
6.00	6	20	60	4	S6126.0
8.00	8	20	64	4	S6128.0
10.00	10	22	70	4	S61210.0
12.00	12	25	75	4	S61212.0

S216

- Frese
- Schafffräser
- Vingerfrees
- Fraises de finition

S216 ■ 1.6 2.3 2.4 4.3 5.3

S216 **HM** **N** **Z 4** $\lambda 40^\circ$ $\gamma 3^\circ$ **DIN 6535HA** **AITIN** **h9**

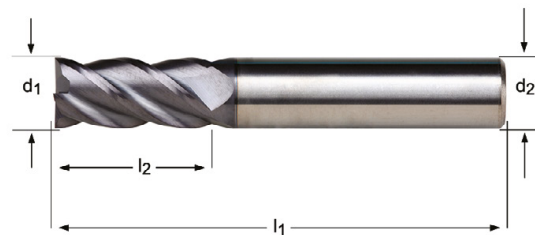

d_1 \varnothing mm	d_2 $\varnothing h_6$ mm	l_2 mm	l_1 mm	z	S216
2.00	4	6.5	40	4	S2162.0
3.00	3	9	40	4	S2163.0XD3
3.00	6	9	50	4	S2163.0XD6
4.00	4	12	50	4	S2164.0XD4
4.00	6	12	50	4	S2164.0XD6
5.00	5	15	50	4	S2165.0
6.00	6	16	50	4	S2166.0
8.00	8	20	64	4	S2168.0
10.00	10	22	70	4	S21610.0
12.00	12	25	75	4	S21612.0
14.00	14	32	90	4	S21614.0
16.00	16	32	90	4	S21616.0
18.00	18	38	100	4	S21618.0
20.00	20	38	100	4	S21620.0

- S904** • Frese
• Schafffräser
- S944** • Vingerfrees
• Fraises de finition

S904	▪	1.1	1.2	1.3	1.4	3.1	3.3	4.1	5.1	6.1	6.2	6.3								
	•	1.5	1.6	3.2	3.4	4.2	4.3	5.2	5.3	6.4	7.1	7.2	7.3	8.1	8.2	8.3				
S944	▪	1.1	1.2	1.3	1.4	1.5	3.1	3.2	3.3	3.4	4.1	5.1	6.1	6.2	6.3					
	•	1.6	4.2	4.3	5.2	5.3	6.4	7.1	7.2	7.3	8.1	8.2	8.3							

S904	HM		N	Z 4		$\lambda 30^\circ$ $\gamma 12^\circ$	DIN 6535HA		h12			
S944	HM		N	Z 4		$\lambda 30^\circ$ $\gamma 12^\circ$	DIN 6535HB	TiAIN	h12			

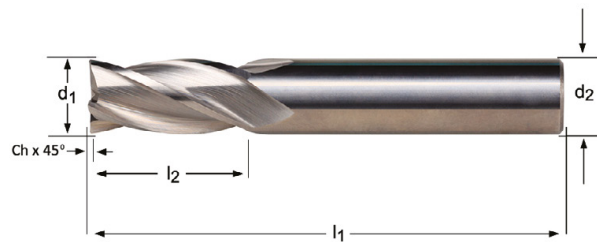

d ₁ Ø mm	Ch ±0.03x45° mm	d ₂ Øh ₆ mm	l ₂ mm	l ₁ mm	z	S904	S944
2.00	0.08	3	6	38	4	S9042.0	S9442.0 ²⁾
2.50	0.08	3	9	38	4	S9042.5	S9442.5 ²⁾
3.00	0.08	3	12	38	4	S9043.0	S9443.0 ²⁾
4.00	0.08	4	14	50	4	S9044.0	S9444.0 ²⁾
5.00	0.13	5	16	50	4	S9045.0	S9445.0 ²⁾
6.00	0.13	6	19	57	4	S9046.0	S9446.0
7.00	0.13	8	19	63	4	S9047.0	S9447.0
8.00	0.13	8	19	63	4	S9048.0	S9448.0
9.00	0.13	10	21	72	4	S9049.0	S9449.0
10.00	0.20	10	22	72	4	S90410.0	S94410.0 ¹⁾
12.00	0.20	12	25	73	4	S90412.0	S94412.0 ¹⁾
14.00	0.20	14	30	83	4	S90414.0	S94414.0 ¹⁾
16.00	0.20	16	32	92	4	S90416.0	S94416.0 ¹⁾
18.00	0.20	18	32	92	4	S90418.0	S94418.0 ¹⁾
20.00	0.30	20	38	104	4	S90420.0	S94420.0 ¹⁾

¹⁾ Ch ± 0.05x45° mm

²⁾ Codolo liscio / Zylinderschaft / Cilindrische schacht / queue cylindrique

- S717** • Frese
• Schafffräser
- S217** • Vingerfrees
• Fraises de finition

S717	▪	1.1	1.2	1.3	1.4	1.5	2.1	2.2	3.1	3.2	3.3	3.4	4.2	5.2
	•	6.1	6.2	6.3	6.4	7.1	7.2	7.3	7.4					
S217	▪	1.6	2.3	2.4	4.3	5.3								

S717	HM		N	Z 4		$\lambda 40^\circ$ $\gamma 10^\circ$	DIN 6535HA		AICrN	h9		
S217	HM		N	Z 4		$\lambda 40^\circ$ $\gamma 3^\circ$	DIN 6535HA		AlTiN	h9		

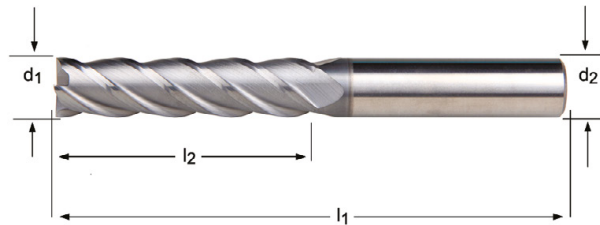

d_1 \varnothing mm	d_2 $\varnothing h_6$ mm	l_2 mm	l_1 mm	z	S717	S217
3.00	3	19	60	4	S7173.0	S2173.0XD3
3.00	6	19	75	4		S2173.0XD6
4.00	4	19	60	4	S7174.0	S2174.0XD4
4.00	6	19	75	4		S2174.0XD6
5.00	5	19	60	4	S7175.0	S2175.0
6.00	6	31	75	4	S7176.0	S2176.0
8.00	8	31	75	4	S7178.0	S2178.0
10.00	10	31	75	4	S71710.0	S21710.0
12.00	12	50	100	4	S71712.0	S21712.0
14.00	14	57	125	4	S71714.0	S21714.0
16.00	16	57	125	4	S71716.0	S21716.0
18.00	18	57	125	4	S71718.0	S21718.0
20.00	20	57	125	4	S71720.0	S21720.0

- S718** • Frese
• Schafffräser
- S218** • Vingerfrees
• Fraises de finition

S718	▪	1.1	1.2	1.3	1.4	1.5	2.1	2.2	3.1	3.2	3.3	3.4	4.2	5.2
	•	6.1	6.2	6.3	6.4	7.1	7.2	7.3	7.4					
S218	▪	1.6	2.3	2.4	4.3	5.3								

S718	HM		N	Z 4		λ 40° γ 10°	DIN 6535HA	AlCrN	h9		
S218	HM		N	Z 4		λ 40° γ 3°	DIN 6535HA	AlTiN	h9		

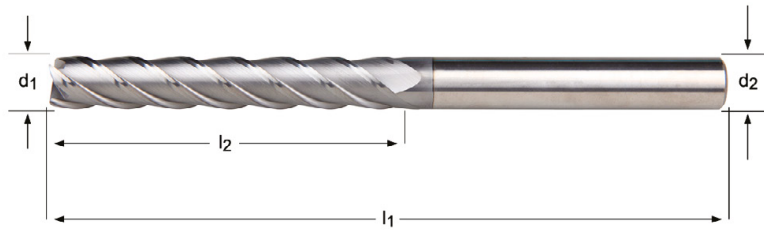

d_1 Ø mm	d_2 Ø _{h6} mm	l_2 mm	l_1 mm	z	S718	S218
3.00	3	25	100	4	S7183.0	S2183.0
4.00	4	31	100	4	S7184.0	S2184.0
5.00	5	31	100	4	S7185.0	S2185.0
6.00	6	38	100	4	S7186.0	S2186.0
8.00	8	41	100	4	S7188.0	S2188.0
10.00	10	57	125	4	S71810.0	S21810.0
12.00	12	75	150	4	S71812.0	S21812.0
14.00	14	75	150	4	S71814.0	S21814.0
16.00	16	75	150	4	S71816.0	S21816.0
18.00	18	75	150	4	S71818.0	S21818.0
20.00	20	75	150	4	S71820.0	S21820.0

- S761** • Frese
• Schafffräser
- S260** • Vingerfrees
• Fraises de finition

S761	▪	1.1	1.2	1.3	1.4	1.5	2.1	2.2	3.1	3.2	3.3	3.4	4.2	5.2
S260	▪	1.6	1.7	2.3	2.4	4.3	5.3							

S761	HM		N	Z 4		$\lambda 40^\circ$ $\gamma 10^\circ$	DIN 6535HA		h9		
S260	HM		N	Z 4		$\lambda 40^\circ$ $\gamma 4^\circ$	DIN 6535HA		h9		

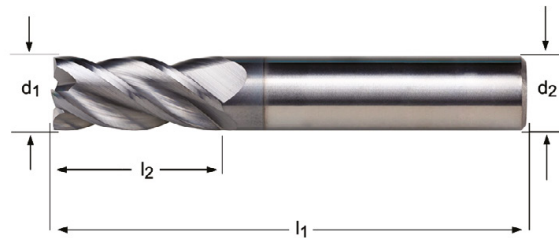





d_1 \varnothing mm	d_2 $\varnothing h_6$ mm	l_2 mm	l_1 mm	z	S761	S260
3.00	6	9	57	4	S7613.0	S2603.0
4.00	6	12	57	4	S7614.0	S2604.0
5.00	6	13	57	4	S7615.0	S2605.0
6.00	6	13	57	4	S7616.0	S2606.0
8.00	8	20	64	4	S7618.0	S2608.0
10.00	10	22	72	4	S76110.0	S26010.0
12.00	12	26	83	4	S76112.0	S26012.0
14.00	14	32	83	4	S76114.0	S26014.0
16.00	16	32	92	4	S76116.0	S26016.0
18.00	18	38	92	4		S26018.0
20.00	20	38	104	4	S76120.0	S26020.0

S766

- Frese
- Schafffräser
- Vingerfrees
- Fraises de finition

S766 ■ 1.1 1.2 1.3 1.4 1.5 2.1 2.2 3.1 3.2 3.3 3.4 4.2 5.2

S766 **HM**  **N**      **h9**  

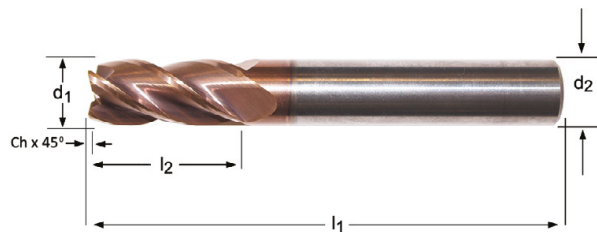

d_1 Ø mm	Ch ±0.02x45° mm	d_2 Ø _{h6} mm	l_2 mm	l_1 mm	z	S766
4.00	0.10	6	11	57	4	S7664.0
5.00	0.10	6	13	57	4	S7665.0
6.00	0.10	6	13	57	4	S7666.0
8.00	0.20	8	20	64	4	S7668.0
10.00	0.20	10	22	72	4	S76610.0
12.00	0.20	12	26	83	4	S76612.0
14.00	0.30	14	26	83	4	S76614.0
16.00	0.30	16	32	92	4	S76616.0
20.00	0.40	20	38	104	4	S76620.0

- S225** • Frese a finire
• Feinstschicht Fräser
- S525** • Frees voor finishing
• Fraises de finition

S225	▪	1.6	2.3	2.4	4.3	5.3
S525	▪	1.7	1.8			

S225	HM		N	Z 6-8		$\lambda 50^\circ$ $\gamma 3^\circ$	DIN 6535HA		AITIN	h9	
S525	HM		N	Z 6-8		$\lambda 50^\circ$ $\gamma -26^\circ$	DIN 6535HA		TISIN	h9	

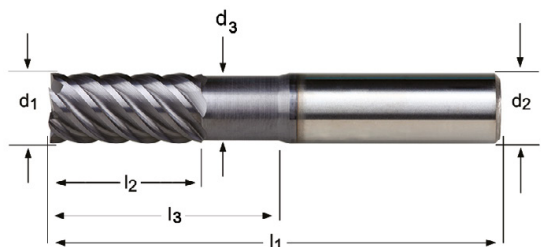

d_1 Ø mm	d_2 Ø _{h6} mm	l_2 mm	l_1 mm	z	l_3 mm	d_3 Ø mm	S225	S525
3.00	6	8	50	6	20.0	2.8	S2253.0	S5253.0
4.00	6	11	50	6	20.0	3.7	S2254.0	S5254.0
6.00	6	15	50	6	20.0	5.5	S2256.0	S5256.0
8.00	8	20	64	6	30.0	7.4	S2258.0	S5258.0
10.00	10	22	70	6	32.0	9.2	S22510.0	S52510.0
12.00	12	25	75	6	37.0	11.0	S22512.0	S52512.0
14.00	14	30	90	6	44.0	13.0	S22514.0	S52514.0
16.00	16	30	90	8	46.0	15.0	S22516.0	S52516.0
18.00	18	35	100	8	53.0	17.0	S22518.0	S52518.0
20.00	20	38	100	8	58.0	19.0	S22520.0	S52520.0

S226 • Frese a finire
• Feinstschicht Fräser

S526 • Frees voor finishing
• Fraises de finition

S226	▪	1.6	2.3	2.4	4.3	5.3
S526	▪	1.7	1.8			

S226	HM		N	Z 6-8		$\lambda 50^\circ$ $\gamma 3^\circ$	DIN 6535HA		h9	
S526	HM		N	Z 6-8		$\lambda 50^\circ$ $\gamma -26^\circ$	DIN 6535HA		h9	

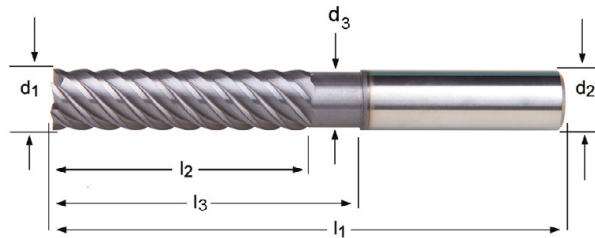

d_1 Ø mm	d_2 Ø _{h_s} mm	l_2 mm	l_1 mm	z	l_3 mm	d_3 Ø mm	S226	S526
3.00	6	19	75	6	30.0	2.8	S2263.0	S5263.0
4.00	6	19	75	6	32.0	3.7	S2264.0	S5264.0
6.00	6	31	75	6	40.0	5.5	S2266.0	S5266.0
8.00	8	31	75	6	40.0	7.4	S2268.0	S5268.0
10.00	10	45	100	6	60.0	9.2	S22610.0	S52610.0
12.00	12	50	100	6	60.0	11.0	S22612.0	S52612.0
14.00	14	57	125	6	85.0	13.0	S22614.0	S52614.0
16.00	16	57	125	8	85.0	15.0	S22616.0	S52616.0
18.00	18	57	125	8	85.0	17.0	S22618.0	S52618.0
20.00	20	57	125	8	85.0	19.0	S22620.0	S52620.0

- S227** • Frese a finire
• Feinstschicht Fräser
- S527** • Frees voor finishing
• Fraises de finition

S227	▪	1.6	2.3	2.4	4.3	5.3
S527	▪	1.7	1.8			

S227	HM		N	Z 6-8		$\lambda 50^\circ$ $\gamma 3^\circ$	DIN 6535HA		h9	
S527	HM		N	Z 6-8		$\lambda 50^\circ$ $\gamma -26^\circ$	DIN 6535HA		h9	

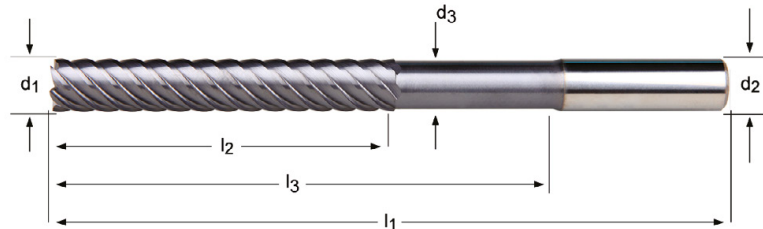

d_1 Ø mm	d_2 Ø _{h6} mm	l_2 mm	l_1 mm	z	l_3 mm	d_3 Ø mm	S227	S527
3.00	6	25	100	6	60.0	2.8		S5273.0
4.00	6	31	100	6	60.0	3.7		S5274.0
6.00	6	38	100	6	60.0	5.5	S2276.0	S5276.0
8.00	8	41	100	6	60.0	7.4	S2278.0	S5278.0
10.00	10	57	125	6	85.0	9.2	S22710.0	S52710.0
12.00	12	75	150	6	110.0	11.0	S22712.0	S52712.0
14.00	14	75	150	6	110.0	13.0	S22714.0	
16.00	16	75	150	8	110.0	15.0	S22716.0	S52716.0
18.00	18	75	150	8	110.0	17.0	S22718.0	
20.00	20	75	150	8	110.0	19.0	S22720.0	S52720.0

S765

- Frese a sgrossare
- Schruppfräser
- Ruwfreies
- Fraises d'ébauche

S765 ■ 1.1 1.2 1.3 1.4 1.5 2.1 2.2 3.1 3.2 3.3 3.4 4.2 5.2

S765 **HM**  **NR**  **Z 4**   **λ 40°**
γ 10°  **AlCrN**  

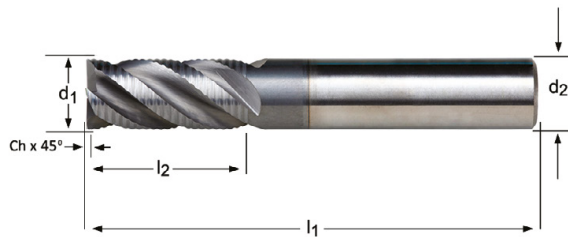

d_1 Ø mm	Ch ±0.02x45° mm	d_2 Ø h_6 mm	l_2 mm	l_1 mm	z	S765
6.00	0.10	6	16	50	4	S7656.0
8.00	0.20	8	20	64	4	S7658.0
10.00	0.20	10	22	70	4	S76510.0
12.00	0.20	12	26	75	4	S76512.0
14.00	0.30	14	32	90	4	S76514.0
16.00	0.30	16	32	90	4	S76516.0
18.00	0.30	18	38	100	4	S76518.0
20.00	0.40	20	38	100	4	S76520.0

S264

- Frese a sgrossare
- Schruppfräser
- Ruwfrees
- Fraises d'ébauche

S264 ■ 1.6 1.7 2.3 2.4 4.3 5.3

S264 **HM** **NR** **Z 4** $\lambda 40^\circ$ $\gamma 4^\circ$ **h9**

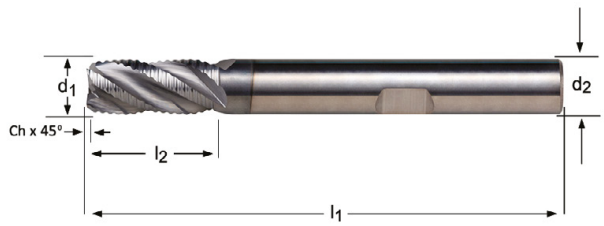

d_1 \varnothing mm	Ch $\pm 0.02 \times 45^\circ$ mm	d_2 $\varnothing h_6$ mm	l_2 mm	l_1 mm	z	S264
6.00	0.10	6	13	57	4	S2646.0
8.00	0.20	8	20	64	4	S2648.0
10.00	0.20	10	22	72	4	S26410.0
12.00	0.20	12	26	83	4	S26412.0
14.00	0.30	14	26	83	4	S26414.0
16.00	0.30	16	32	92	4	S26416.0
18.00	0.30	18	32	92	4	S26418.0
20.00	0.40	20	38	104	4	S26420.0

- S524**
- Frese raggiate
 - Schafffräser mit Eckenradius
 - Vingerfrees met hoekradius
 - Fraises à matrice torique

S524 ■ 1.7 1.8

S524 **HM**  **N**  **Z 4**  **λ 40°**
γ -6°  **DIN 6535HA**  **TISIN** **h9**  **DORMER**

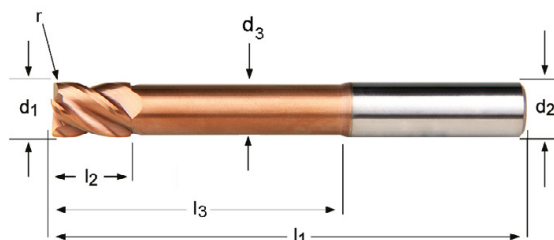

S524



3.00 - 16.00

d_1 Ø mm	r ±0.01 mm	d_2 Ø _{h6} mm	l_2 mm	l_1 mm	z	l_3 mm	d_3 Ø mm	S524
3.00	0.30	6	5	75	4	30.0	2.8	S5243.0XR0.3
4.00	0.30	6	8	75	4	32.0	3.7	S5244.0XR0.3
4.00	0.50	6	8	75	4	32.0	3.7	S5244.0XR0.5
5.00	0.30	6	9	75	4	32.0	4.6	S5245.0XR0.3
5.00	0.50	6	9	75	4	32.0	4.6	S5245.0XR0.5
6.00	0.30	6	10	75	4	40.0	5.5	S5246.0XR0.3
6.00	0.50	6	10	75	4	40.0	5.5	S5246.0XR0.5
6.00	1.00	6	10	75	4	40.0	5.5	S5246.0XR1.0
8.00	0.30	8	12	75	4	40.0	7.4	S5248.0XR0.3
8.00	0.50	8	12	75	4	40.0	7.4	S5248.0XR0.5
8.00	1.00	8	12	75	4	40.0	7.4	S5248.0XR1.0
10.00	0.50	10	14	75	4	40.0	9.2	S52410.0XR0.5
10.00	1.00	10	14	75	4	40.0	9.2	S52410.0XR1.0
10.00	2.00	10	14	75	4	40.0	9.2	S52410.0XR2.0
12.00	0.50	12	16	100	4	60.0	11.0	S52412.0XR0.5
12.00	1.00	12	16	100	4	60.0	11.0	S52412.0XR1.0
12.00	2.00	12	16	100	4	60.0	11.0	S52412.0XR2.0
16.00	0.50	16	22	125	4	85.0	15.0	S52416.0XR0.5
16.00	1.00	16	22	125	4	85.0	15.0	S52416.0XR1.0
16.00	2.00	16	22	125	4	85.0	15.0	S52416.0XR2.0
16.00	3.00	16	22	125	4	85.0	15.0	S52416.0XR3.0

S521

- Frese raggate
- Schafffräser mit Eckenradius
- Vingerfrees met hoekradius
- Fraises à matrice torique

S521 ■ 1.7 1.8

S521 **HM** **N** **Z 4** **$\lambda 45^\circ$**
 $\gamma -10^\circ$ **DIN 6535HA** **TISIN** **h9** **DORMER**

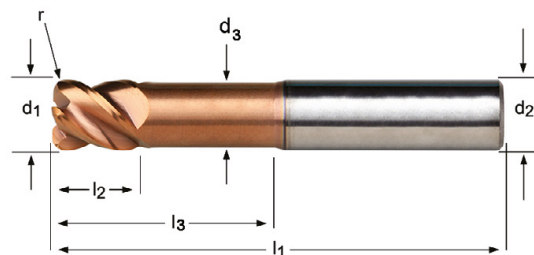

d_1 Ø mm	r ±0.01 mm	d_2 Øh ₆ mm	l ₂ mm	l ₁ mm	z	l ₃ mm	d_3 Ø mm	S521
3.00	0.30	6	4	60	4	14.0	2.8	S5213.0XR0.3
4.00	0.30	6	5	60	4	16.0	3.7	S5214.0XR0.3
4.00	0.50	6	5	60	4	16.0	3.7	S5214.0XR0.5
5.00	0.30	6	6	60	4	18.0	4.6	S5215.0XR0.3
5.00	0.50	6	6	60	4	18.0	4.6	S5215.0XR0.5
6.00	0.50	6	7	60	4	20.0	5.5	S5216.0XR0.5
6.00	1.00	6	7	60	4	20.0	5.5	S5216.0XR1.0
8.00	0.50	8	9	64	4	26.0	7.4	S5218.0XR0.5
8.00	1.00	8	9	64	4	26.0	7.4	S5218.0XR1.0
10.00	1.00	10	11	70	4	31.0	9.2	S52110.0XR1.0
10.00	2.00	10	11	70	4	31.0	9.2	S52110.0XR2.0
12.00	1.00	12	13	75	4	37.0	11.0	S52112.0XR1.0
12.00	2.00	12	13	75	4	37.0	11.0	S52112.0XR2.0
16.00	1.00	16	17	90	4	43.0	15.0	S52116.0XR1.0
16.00	2.00	16	17	90	4	43.0	15.0	S52116.0XR2.0
16.00	3.00	16	17	90	4	43.0	15.0	S52116.0XR3.0

S523

- Frese raggiate
- Schafffräser mit Eckenradius
- Vingerfrees met hoekradius
- Fraises à matrice torique

S523 ■ 1.7 1.8

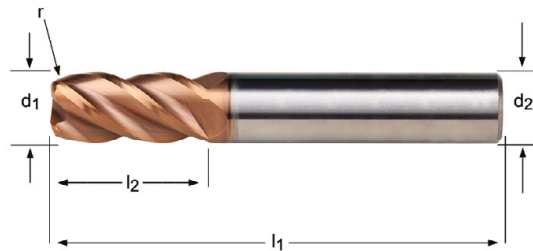

d_1 Ø mm	r ±0.01 mm	d_2 Ø _{h6} mm	l_2 mm	l_1 mm	z	S523
1.50	0.20	6	4.5	50	4	S5231.5XR0.2
2.00	0.20	6	6.5	50	4	S5232.0XR0.2
3.00	0.20	3	9	50	4	S5233.0XR0.2XD3
3.00	0.30	3	9	50	4	S5233.0XR0.3XD3
3.00	0.20	6	9	50	4	S5233.0XR0.2XD6
3.00	0.30	6	9	50	4	S5233.0XR0.3XD6
3.00	0.50	6	9	50	4	S5233.0XR0.5XD6
4.00	0.30	4	12	50	4	S5234.0XR0.3XD4
4.00	0.50	4	12	50	4	S5234.0XR0.5XD4
4.00	0.30	6	12	50	4	S5234.0XR0.3XD6
4.00	0.50	6	12	50	4	S5234.0XR0.5XD6
5.00	0.30	5	15	50	4	S5235.0XR0.3XD5
5.00	0.50	5	15	50	4	S5235.0XR0.5XD5
5.00	0.30	6	15	50	4	S5235.0XR0.3XD6
5.00	0.50	6	15	50	4	S5235.0XR0.5XD6
6.00	0.30	6	16	50	4	S5236.0XR0.3
6.00	0.50	6	16	50	4	S5236.0XR0.5
6.00	1.00	6	16	50	4	S5236.0XR1.0
8.00	0.30	8	20	64	4	S5238.0XR0.3
8.00	0.50	8	20	64	4	S5238.0XR0.5
8.00	1.00	8	20	64	4	S5238.0XR1.0
8.00	2.00	8	20	64	4	S5238.0XR2.0
10.00	0.50	10	22	70	4	S52310.0XR0.5
10.00	1.00	10	22	70	4	S52310.0XR1.0
10.00	1.50	10	22	70	4	S52310.0XR1.5
10.00	2.00	10	22	70	4	S52310.0XR2.0
12.00	0.50	12	25	75	4	S52312.0XR0.5
12.00	1.00	12	25	75	4	S52312.0XR1.0
12.00	2.00	12	25	75	4	S52312.0XR2.0
12.00	3.00	12	25	75	4	S52312.0XR3.0
16.00	0.50	16	32	90	4	S52316.0XR0.5
16.00	1.00	16	32	90	4	S52316.0XR1.0
16.00	2.00	16	32	90	4	S52316.0XR2.0
16.00	3.00	16	32	90	4	S52316.0XR3.0

S763

- Frese raggiate
- Schafffräser mit Eckenradius
- Vingerfrees met hoekradius
- Fraises à matrice torique

S763 ■ 1.1 1.2 1.3 1.4 1.5 2.1 2.2 3.1 3.2 3.3 3.4 4.2 5.2

S763 **HM** **N** $\lambda 40^\circ$ $\gamma 10^\circ$ **h9**

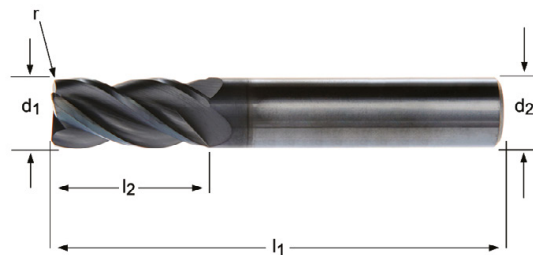

d_1 \varnothing mm	r ± 0.01 mm	d_2 $\varnothing h_6$ mm	l_2 mm	l_1 mm	z	S763
3.00	0.30	3	9	40	4	S7633.0XR0.3
4.00	0.30	4	12	50	4	S7634.0XR0.3
4.00	0.50	4	12	50	4	S7634.0XR0.5
5.00	0.30	5	15	50	4	S7635.0XR0.3
5.00	0.50	5	15	50	4	S7635.0XR0.5
6.00	0.50	6	16	50	4	S7636.0XR0.5
6.00	1.00	6	16	50	4	S7636.0XR1.0
8.00	0.50	8	20	64	4	S7638.0XR0.5
8.00	1.00	8	20	64	4	S7638.0XR1.0
10.00	0.50	10	22	70	4	S76310.0XR0.5
10.00	1.00	10	22	70	4	S76310.0XR1.0
10.00	2.00	10	22	70	4	S76310.0XR2.0
12.00	1.00	12	25	75	4	S76312.0XR1.0
12.00	2.00	12	25	75	4	S76312.0XR2.0
12.00	3.00	12	25	75	4	S76312.0XR3.0
14.00	1.50	14	32	90	4	S76314.0XR1.5
16.00	1.00	16	32	90	4	S76316.0XR1.0
16.00	2.00	16	32	90	4	S76316.0XR2.0
16.00	3.00	16	32	90	4	S76316.0XR3.0
18.00	2.00	18	38	100	4	S76318.0XR2.0
20.00	3.00	20	38	100	4	S76320.0XR3.0

- S262**
- Frese raggate
 - Schafffräser mit Eckenradius
 - Vingerfrees met hoekradius
 - Fraises à matrice torique

S262 ■ 1.6 1.7 2.3 2.4 4.3 5.3

S262 **HM**  **N**   $\lambda 40^\circ$ $\gamma 4^\circ$  **DIN 6535HA**  **AlCrN** **h9**  **DORMER**

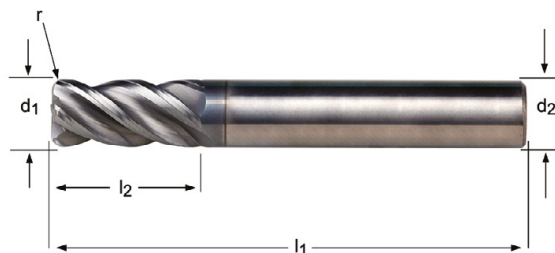

d_1 \emptyset mm	r ± 0.01 mm	d_2 $\emptyset h_6$ mm	l_2 mm	l_1 mm	z	S262
3.00	0.30	6	9	50	4	S2623.0XR0.3
3.00	0.50	6	9	50	4	S2623.0XR0.5
4.00	0.30	6	12	57	4	S2624.0XR0.3
4.00	0.50	6	12	57	4	S2624.0XR0.5
4.00	1.00	6	12	57	4	S2624.0XR1.0
5.00	0.30	6	15	57	4	S2625.0XR0.3
5.00	0.50	6	15	57	4	S2625.0XR0.5
6.00	0.30	6	16	57	4	S2626.0XR0.3
6.00	0.50	6	16	57	4	S2626.0XR0.5
6.00	1.00	6	16	57	4	S2626.0XR1.0
8.00	0.30	8	20	64	4	S2628.0XR0.3
8.00	0.50	8	20	64	4	S2628.0XR0.5
8.00	1.00	8	20	64	4	S2628.0XR1.0
8.00	1.50	8	20	64	4	S2628.0XR1.5
8.00	2.00	8	20	64	4	S2628.0XR2.0
10.00	0.30	10	22	72	4	S26210.0XR0.3
10.00	0.50	10	22	72	4	S26210.0XR0.5
10.00	1.00	10	22	72	4	S26210.0XR1.0
10.00	1.50	10	22	72	4	S26210.0XR1.5
10.00	2.00	10	22	72	4	S26210.0XR2.0
12.00	0.30	12	26	83	4	S26212.0XR0.3
12.00	0.50	12	26	83	4	S26212.0XR0.5
12.00	1.00	12	26	83	4	S26212.0XR1.0
12.00	2.00	12	26	83	4	S26212.0XR2.0
12.00	2.50	12	26	83	4	S26212.0XR2.5
12.00	3.00	12	26	83	4	S26212.0XR3.0
14.00	0.30	14	32	83	4	S26214.0XR0.3
14.00	0.50	14	32	83	4	S26214.0XR0.5
14.00	1.00	14	32	83	4	S26214.0XR1.0
14.00	2.00	14	32	83	4	S26214.0XR2.0
14.00	3.00	14	32	83	4	S26214.0XR3.0
16.00	0.30	16	32	92	4	S26216.0XR0.3
16.00	0.50	16	32	92	4	S26216.0XR0.5
16.00	1.00	16	32	92	4	S26216.0XR1.0
16.00	2.00	16	32	92	4	S26216.0XR2.0
16.00	2.50	16	32	92	4	S26216.0XR2.5
16.00	3.00	16	32	92	4	S26216.0XR3.0
16.00	4.00	16	32	92	4	S26216.0XR4.0
18.00	0.30	18	38	92	4	S26218.0XR0.3
18.00	0.50	18	38	92	4	S26218.0XR0.5

d_1 Ø mm	r ±0.01 mm	d_2 Ø _{h₆} mm	l_2 mm	l_1 mm	z	S262
18.00	1.00	18	38	92	4	S26218.0XR1.0
18.00	2.00	18	38	92	4	S26218.0XR2.0
18.00	3.00	18	38	92	4	S26218.0XR3.0
20.00	0.30	20	38	104	4	S26220.0XR0.3
20.00	0.50	20	38	104	4	S26220.0XR0.5
20.00	1.00	20	38	104	4	S26220.0XR1.0
20.00	2.00	20	38	104	4	S26220.0XR2.0
20.00	2.50	20	38	104	4	S26220.0XR2.5
20.00	3.00	20	38	104	4	S26220.0XR3.0
20.00	4.00	20	38	104	4	S26220.0XR4.0

- S767**
- Frese raggiate
 - Schafffräser mit Eckenradius
 - Vingerfrees met hoekradius
 - Fraises à matrice torique

S767 ■ 1.1 1.2 1.3 1.4 1.5 2.1 2.2 3.1 3.2 3.3 3.4 4.2 5.2

S767 **HM**  **N**    **DIN 6535HA**  **h9** 

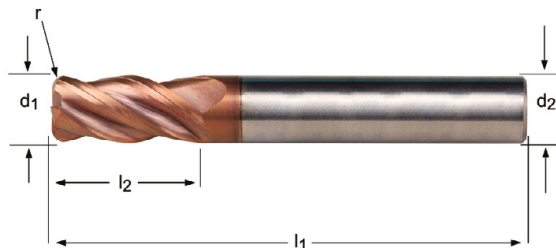

d_1 Ø mm	r ±0.01 mm	d_2 Ø h_6 mm	l_2 mm	l_1 mm	z	S767
4.00	0.30	6	11	57	4	S7674.0XR0.3
4.00	0.50	6	11	57	4	S7674.0XR0.5
5.00	0.30	6	13	57	4	S7675.0XR0.3
5.00	0.50	6	13	57	4	S7675.0XR0.5
6.00	0.30	6	13	57	4	S7676.0XR0.3
6.00	0.50	6	13	57	4	S7676.0XR0.5
6.00	1.00	6	13	57	4	S7676.0XR1.0
8.00	0.30	8	20	64	4	S7678.0XR0.3
8.00	0.50	8	20	64	4	S7678.0XR0.5
8.00	1.00	8	20	64	4	S7678.0XR1.0
10.00	0.30	10	22	72	4	S76710.0XR0.3
10.00	0.50	10	22	72	4	S76710.0XR0.5
10.00	1.00	10	22	72	4	S76710.0XR1.0
12.00	0.30	12	26	83	4	S76712.0XR0.3
12.00	0.50	12	26	83	4	S76712.0XR0.5
12.00	1.00	12	26	83	4	S76712.0XR1.0
12.00	2.00	12	26	83	4	S76712.0XR2.0
16.00	0.30	16	32	92	4	S76716.0XR0.3
16.00	0.50	16	32	92	4	S76716.0XR0.5
16.00	1.00	16	32	92	4	S76716.0XR1.0
16.00	2.00	16	32	92	4	S76716.0XR2.0
20.00	0.30	20	38	104	4	S76720.0XR0.3
20.00	0.50	20	38	104	4	S76720.0XR0.5
20.00	1.00	20	38	104	4	S76720.0XR1.0
20.00	2.00	20	38	104	4	S76720.0XR2.0

- S536**
- Frese ad alta velocità
 - Hoch-Vorschub Fräser
 - Frees voor hoge voeding
 - Fraises grandes avance de Finition

S536 ■ 1.7 1.8

S536 **HM** **N** **Z 4-6** **$\lambda 25^\circ$**
 $\gamma 0^\circ$ **DIN 6535HA** **TISIN** **h9** **DORMER**

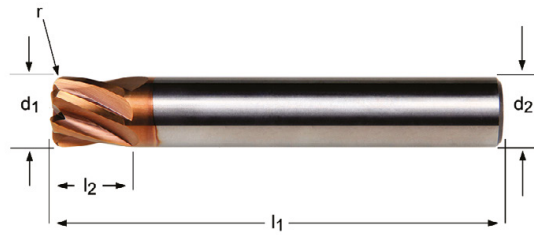

d_1 \varnothing mm	r ± 0.01 mm	d_2 $\varnothing h_6$ mm	l_2 mm	l_1 mm	z	S536
6.00	1.00	6	6	60	4	S5366.0XR1.0
8.00	2.00	8	8	64	6	S5368.0XR2.0
10.00	2.00	10	10	75	6	S53610.0XR2.0
12.00	2.00	12	12	75	6	S53612.0XR2.0

- S229**
- Frese semisferiche
 - Radius - Kopierfräser
 - Radiusfreas
 - Fraises de finition bout hémisphérique

S229 ■ 1.6 2.3 2.4 4.3 5.3

S229 **HM**  **N** **Z 2**  $\lambda 30^\circ$ $\gamma 3^\circ$ **DIN 6535HA**  **h9**  **DORMER**

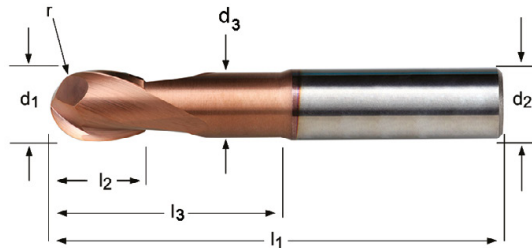

d_1 Ø mm	r +0/-0.02 mm	d_2 Ø _{h6} mm	l_2 mm	l_1 mm	z	l_3 mm	d_3 Ø mm	S229
1.50	0.75	4	3	50	2	6.0	1.4	S2291.5XD4
2.00	1.00	3	4	50	2	8.0	1.9	S2292.0XD3
2.00	1.00	4	4	50	2	8.0	1.9	S2292.0XD4
3.00	1.50	3	5	50	2	14.0	2.8	S2293.0XD3
3.00	1.50	6	5	50	2	14.0	2.8	S2293.0XD6
4.00	2.00	4	8	50	2	20.0	3.7	S2294.0XD4
4.00	2.00	6	8	50	2	20.0	3.7	S2294.0XD6
5.00	2.50	5	9	50	2	20.0	4.6	S2295.0XD5
5.00	2.50	6	9	50	2	20.0	4.6	S2295.0XD6
6.00	3.00	6	10	50	2	20.0	5.5	S2296.0
8.00	4.00	8	12	64	2	30.0	7.4	S2298.0
10.00	5.00	10	14	70	2	32.0	9.2	S22910.0
12.00	6.00	12	16	75	2	38.0	11.0	S22912.0
14.00	7.00	14	32	90	2	44.0	13.0	S22914.0
16.00	8.00	16	32	90	2	46.0	15.0	S22916.0

S231

- Frese semisferiche
- Radius - Kopierfräser
- Radiusfreese
- Fraises de finition bout hémisphérique

S231 ■ 1.6 2.3 2.4 4.3 5.3

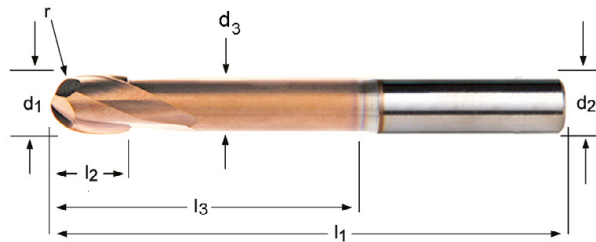

S231 **HM** **N** **Z 2** **λ 30°** **γ 3°** **TiSiN** **h9**



d_1 ∅ mm	r +0/-0.02 mm	d_2 ∅ _{h₆} mm	l_2 mm	l_1 mm	z	l_3 mm	d_3 ∅ mm	S231
1.50	0.75	4	3	75	2	10.0	1.4	S2311.5XD4
2.00	1.00	3	4	60	2	14.0	1.9	S2312.0XD3
2.00	1.00	4	4	75	2	14.0	1.9	S2312.0XD4
3.00	1.50	3	5	60	2	21.0	2.8	S2313.0XD3
3.00	1.50	6	5	75	2	21.0	2.8	S2313.0XD6
4.00	2.00	4	8	60	2	28.0	3.7	S2314.0XD4
4.00	2.00	6	8	75	2	28.0	3.7	S2314.0XD6
5.00	2.50	5	9	60	2	32.0	4.6	S2315.0
6.00	3.00	6	10	75	2	40.0	5.5	S2316.0
8.00	4.00	8	10	75	2	40.0	7.4	S2318.0
10.00	5.00	10	12	75	2	40.0	9.2	S23110.0
12.00	6.00	12	16	100	2	60.0	11.0	S23112.0
16.00	8.00	16	32	125	2	80.0	15.0	S23116.0

- S233**
- Frese semisferiche
 - Radius - Kopierfräser
 - Radiusfreies
 - Fraises de finition bout hémisphérique

S233 ■ 1.6 2.3 2.4 4.3 5.3

S233 **HM**  **N** **Z 2**  $\lambda 30^\circ$ $\gamma 3^\circ$ **DIN 6535HA**  **h9**  **DORMER**

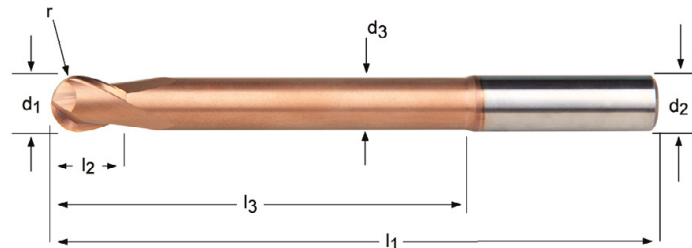

d_1 Ø mm	r +0/-0.02 mm	d_2 Ø _{h6} mm	l_2 mm	l_1 mm	z	l_3 mm	d_3 Ø mm	S233
2.00	1.00	3	4	100	2	20.0	1.9	S2332.0XD3
2.00	1.00	4	4	100	2	20.0	1.9	S2332.0XD4
3.00	1.50	3	5	100	2	30.0	2.8	S2333.0XD3
3.00	1.50	6	5	100	2	30.0	2.8	S2333.0XD6
4.00	2.00	4	8	100	2	40.0	3.7	S2334.0XD4
4.00	2.00	6	8	100	2	40.0	3.7	S2334.0XD6
5.00	2.50	5	9	100	2	50.0	4.6	S2335.0
6.00	3.00	6	10	100	2	60.0	5.5	S2336.0
8.00	4.00	8	12	100	2	60.0	7.4	S2338.0
10.00	5.00	10	14	125	2	85.0	9.2	S23310.0
12.00	6.00	12	16	125	2	85.0	11.0	S23312.0
14.00	7.00	14	32	150	2	110.0	13.0	S23314.0
16.00	8.00	16	32	150	2	110.0	15.0	S23316.0

- S529**
- Frese semisferiche
 - Radius - Kopierfräser
 - Radiusfreies
 - Fraises de finition bout hémisphérique

S529 ■ 1.7 1.8

S529 **HM** **N** **Z 2** **$\lambda 30^\circ$**
 $\gamma -10^\circ$ **DIN 6535HA** **TISIN** **h9** **DORMER**

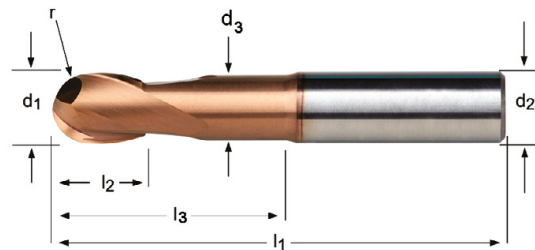

d_1 Ø mm	r +0/-0.02 mm	d_2 Ø _{h6} mm	l_2 mm	l_1 mm	z	l_3 mm	d_3 Ø mm	S529
1.50	0.75	6	3	50	2	6.0	1.4	S5291.5
2.00	1.00	4	4	50	2	8.0	1.9	S5292.0XD4
2.00	1.00	6	4	50	2	8.0	1.9	S5292.0XD6
3.00	1.50	3	5	50	2	14.0	2.8	S5293.0XD3
3.00	1.50	6	5	50	2	14.0	2.8	S5293.0XD6
4.00	2.00	4	8	50	2	20.0	3.7	S5294.0XD4
4.00	2.00	6	8	50	2	20.0	3.7	S5294.0XD6
5.00	2.50	5	9	50	2	20.0	4.6	S5295.0XD5
5.00	2.50	6	9	50	2	20.0	4.6	S5295.0XD6
6.00	3.00	6	10	50	2	20.0	5.5	S5296.0
8.00	4.00	8	12	64	2	30.0	7.4	S5298.0
10.00	5.00	10	14	70	2	32.0	9.2	S52910.0
12.00	6.00	12	16	75	2	38.0	11.0	S52912.0
16.00	8.00	16	32	90	2	46.0	15.0	S52916.0

- S531**
- Frese semisferiche
 - Radius - Kopierfräser
 - Radiusfreese
 - Fraises de finition bout hémisphérique

S531 ■ 1.7 1.8

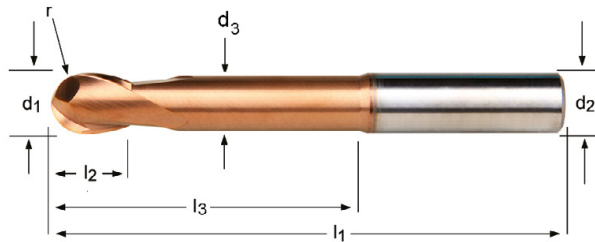

d_1 Ø mm	r +0/-0.02 mm	d_2 Ø _{h6} mm	l_2 mm	l_1 mm	z	l_3 mm	d_3 Ø mm	S531
1.50	0.75	6	3	75	2	10.0	1.4	S5311.5
2.00	1.00	4	4	75	2	14.0	1.9	S5312.0XD4
2.00	1.00	6	4	75	2	14.0	1.9	S5312.0XD6
3.00	1.50	3	5	60	2	21.0	2.8	S5313.0XD3
3.00	1.50	6	5	75	2	21.0	2.8	S5313.0XD6
4.00	2.00	4	8	60	2	28.0	3.7	S5314.0XD4
4.00	2.00	6	8	75	2	28.0	3.7	S5314.0XD6
5.00	2.50	5	9	60	2	32.0	4.6	S5315.0XD5
5.00	2.50	6	9	75	2	32.0	4.6	S5315.0XD6
6.00	3.00	6	10	75	2	40.0	5.5	S5316.0
8.00	4.00	8	12	75	2	40.0	7.4	S5318.0
10.00	5.00	10	14	75	2	40.0	9.2	S53110.0
12.00	6.00	12	16	100	2	60.0	11.0	S53112.0
16.00	8.00	16	32	125	2	80.0	15.0	S53116.0

- S533**
- Frese semisferiche
 - Radius - Kopierfräser
 - Radiusfrees
 - Fraises de finition bout hémisphérique

S533 ■ 1.7 1.8

S533 **HM** **N** **Z 2** **$\lambda 30^\circ$**
 $\gamma -10^\circ$ **TISIN** **h9** **DORMER**

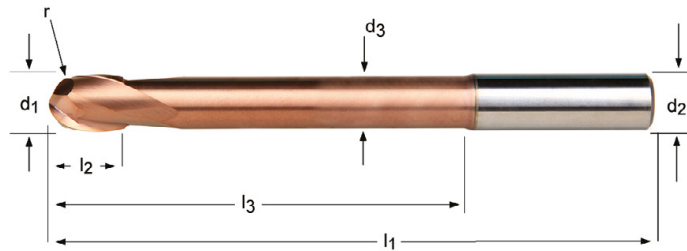

d_1 Ø mm	r +0/-0.02 mm	d_2 Ø mm	l_2 mm	l_1 mm	z	l_3 mm	d_3 Ø mm	S533
2.00	1.00	4	4	100	2	20.0	1.9	S5332.0XD4
2.00	1.00	6	4	100	2	20.0	1.9	S5332.0XD6
3.00	1.50	4	5	100	2	30.0	2.8	S5333.0XD4
3.00	1.50	6	5	100	2	30.0	2.8	S5333.0XD6
4.00	2.00	4	8	100	2	40.0	3.7	S5334.0XD4
4.00	2.00	6	8	100	2	40.0	3.7	S5334.0XD6
5.00	2.50	5	9	100	2	50.0	4.6	S5335.0XD5
5.00	2.50	6	9	100	2	50.0	4.6	S5335.0XD6
6.00	3.00	6	10	100	2	60.0	5.5	S5336.0
8.00	4.00	8	12	100	2	60.0	7.4	S5338.0
10.00	5.00	10	14	125	2	85.0	9.2	S53310.0
12.00	6.00	12	16	125	2	85.0	11.0	S53312.0
14.00	7.00	14	32	150	2	110.0	13.0	S53314.0
16.00	8.00	16	32	150	2	110.0	15.0	S53316.0

- S501**
- Frese semisferiche
 - Radius - Kopierfräser
 - Radiusfreies
 - Fraises de finition bout hémisphérique

S501	▪	1.1	1.2	1.3	1.4	1.5	1.6	2.1	2.2	2.3	3.1	3.2	3.3	3.4	4.1	4.2	4.3	5.1	5.2	5.3	6.1		
		6.2	6.3	6.4	7.1	7.2	7.3	7.4	8.1	8.2	8.3	9.1											
	•	1.7																					

S501

HM

N

Z
2

$\lambda 30^\circ$
 $\gamma 10^\circ$

DIN
6535HA

X-CCEED

h9

DORMER

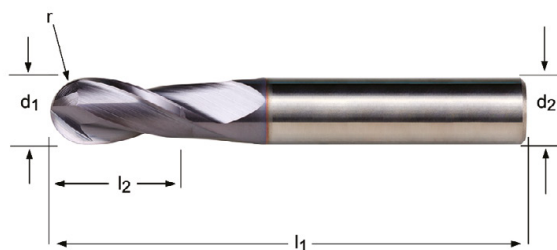

d_1 Ø mm	r ±0.01 mm	d_2 Ø _{h6} mm	l_2 mm	l_1 mm	z	S501
1.00	0.50	3	3	38	2	S5011.0
1.50	0.75	3	3	38	2	S5011.5
2.00	1.00	3	6	38	2	S5012.0
2.50	1.25	3	7	38	2	S5012.5
3.00	1.50	3	7	38	2	S5013.0
4.00	2.00	6	8	57	2	S5014.0
5.00	2.50	6	10	57	2	S5015.0
6.00	3.00	6	10	57	2	S5016.0
7.00	3.50	8	13	63	2	S5017.0
8.00	4.00	8	16	63	2	S5018.0
9.00	4.50	10	16	72	2	S5019.0
10.00	5.00	10	19	72	2	S50110.0
12.00	6.00	12	22	83	2	S50112.0
16.00	8.00	16	26	92	2	S50116.0

- S534**
- Frese semisferiche
 - Radius - Kopierfräser
 - Radiusfrees
 - Fraises de finition bout hémisphérique

S534 ■ 1.7 1.8

S534 **HM** **N** **Z 4** $\lambda 30^\circ$ $\gamma -10^\circ$ **DIN 6535HA** **TISIN** **h9**

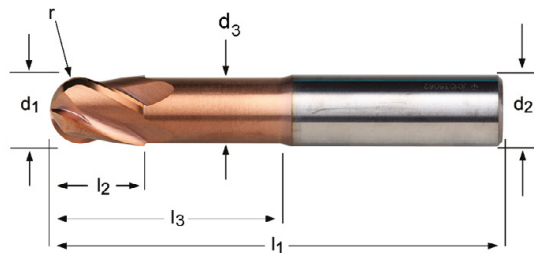

d_1 \emptyset mm	r +0/-0.02 mm	d_2 $\emptyset h_6$ mm	l_2 mm	l_1 mm	z	l_3 mm	d_3 \emptyset mm	S534
3.00	1.50	6	5	50	4	14.0	2.8	S5343.0
4.00	2.00	6	8	50	4	20.0	3.7	S5344.0
5.00	2.50	6	9	50	4	20.0	4.6	S5345.0
6.00	3.00	6	10	50	4	20.0	5.5	S5346.0
8.00	4.00	8	12	64	4	30.0	7.4	S5348.0
10.00	5.00	10	14	70	4	32.0	9.2	S53410.0
12.00	6.00	12	16	75	4	38.0	11.0	S53412.0
14.00	7.00	14	32	90	4	44.0	13.0	S53414.0
16.00	8.00	16	32	90	4	46.0	15.0	S53416.0

- S535**
- Frese semisferiche
 - Radius - Kopierfräser
 - Radiusfreese
 - Fraises de finition bout hémisphérique

S535 ■ 1.7 1.8

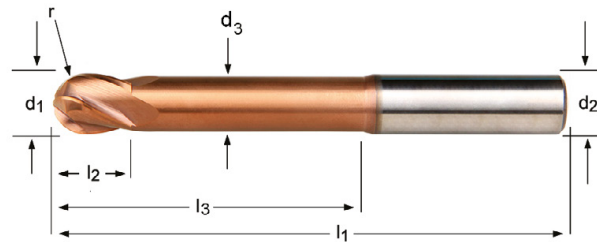

d_1 Ø mm	r +0/-0.02 mm	d_2 Ø _{h6} mm	l_2 mm	l_1 mm	z	l_3 mm	d_3 Ø mm	S535
3.00	1.50	6	5	75	4	21.0	2.8	S5353.0
4.00	2.00	6	8	75	4	28.0	3.7	S5354.0
5.00	2.50	6	9	75	4	32.0	4.6	S5355.0
6.00	3.00	6	10	75	4	40.0	5.5	S5356.0
8.00	4.00	8	12	75	4	40.0	7.4	S5358.0
10.00	5.00	10	14	75	4	40.0	9.2	S53510.0
12.00	6.00	12	16	100	4	60.0	11.0	S53512.0
14.00	7.00	14	32	125	4	80.0	13.0	S53514.0
16.00	8.00	16	32	125	4	80.0	15.0	S53516.0

S511

- Frese semisferiche
- Radius - Kopierfräser
- Radiusfrees
- Fraises de finition bout hémisphérique

S511	▪	1.1	1.2	1.3	1.4	1.5	1.6	2.1	2.2	2.3	3.1	3.2	3.3	3.4	4.1	4.2	4.3	5.1	5.2	5.3	7.3
		7.4	8.2	8.3	9.1																
	•	1.7	6.1	6.2	6.3	6.4	7.1	7.2	8.1												

S511	HM		N	Z 4		λ 30° γ 10°	DIN 6535HA	X-CEED	h9		
------	----	--	---	--------	--	-------------------------------	---------------	--------	----	--	--

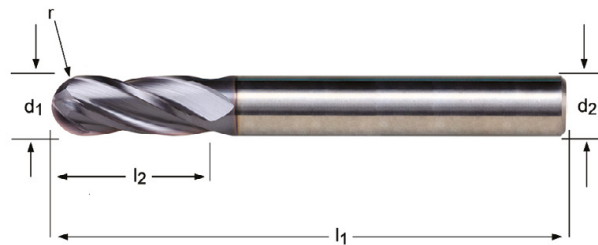

d_1 Ø mm	r ±0.01 mm	d_2 Ø _{h6} mm	l_2 mm	l_1 mm	z	S511
3.00	1.50	6	8	80	4	S5113.0
4.00	2.00	6	11	80	4	S5114.0
5.00	2.50	6	13	80	4	S5115.0
6.00	3.00	6	13	80	4	S5116.0
7.00	3.50	8	16	100	4	S5117.0
8.00	4.00	8	19	100	4	S5118.0
9.00	4.50	10	19	100	4	S5119.0
10.00	5.00	10	22	100	4	S51110.0
12.00	6.00	12	26	100	4	S51112.0
16.00	8.00	16	32	100	4	S51116.0

- S629**
- Frese semisferiche
 - Radius - Kopierfräser
 - Radiusfreese
 - Fraises de finition bout hémisphérique

S629 ■ 6.1 6.2 6.3 6.4 7.1 7.2 7.3 7.4 8.1 8.2

S629 **HM**  **W** **Z 2**  **λ 30°**
γ 15°  **Hi** **h9**  **DORMER**

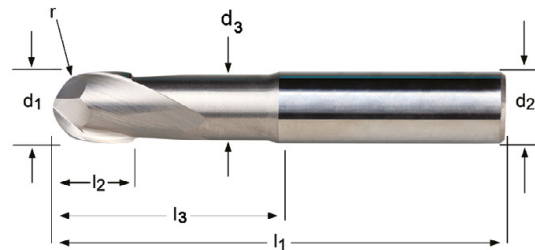

S629



3.00 - 20.00

d_1 Ø mm	r +0/-0.02 mm	d_2 Ø mm	l_2 mm	l_1 mm	z	l_3 mm	d_3 Ø mm	S629
3.00	1.50	6	5	57	2	20.0	2.8	S6293.0
4.00	2.00	6	6	57	2	20.0	3.7	S6294.0
5.00	2.50	6	7	57	2	20.0	4.6	S6295.0
6.00	3.00	6	8	57	2	20.0	5.5	S6296.0
8.00	4.00	8	10	64	2	25.0	7.4	S6298.0
10.00	5.00	10	12	75	2	35.0	9.2	S62910.0
12.00	6.00	12	14	75	2	35.0	11.0	S62912.0
16.00	8.00	16	18	90	2	45.0	15.0	S62916.0
20.00	10.00	20	22	100	2	50.0	19.0	S62920.0

S739

- Frese per smussi - 60°
- Fasenfräser - 60°
- Verzinkfrees - 60°
- Fraise à chanfreiner 60°

S740

- Frese per smussi - 90°
- Fasenfräser - 90°
- Verzinkfrees - 90°
- Fraise à chanfreiner 90°

S739; S740

1.1	1.2	1.3	1.4	1.5	2.1	2.2	3.1	3.2	3.3	3.4	4.2	5.2	6.1	6.2	6.3	6.4
7.1	7.2	7.3	7.4													

S739	HM		N	Z 2		$\lambda 40^\circ$ $\gamma 10^\circ$	DIN 6535HA	AITIN	h9		
S740	HM		N	Z 2		$\lambda 40^\circ$ $\gamma 10^\circ$	DIN 6535HA	AITIN	h9		

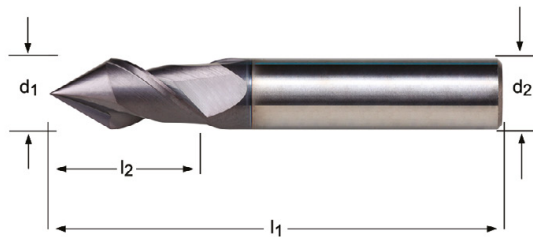

	d_1 Ø mm	d_2 Øh ₆ mm	l_2 mm	l_1 mm	z	S739	S740
60°	3.00	3	9	40	2	S7393.0	
90°	3.00	3	9	40	2		S7403.0
60°	4.00	4	12	50	2	S7394.0	
90°	4.00	4	12	50	2		S7404.0
60°	5.00	5	15	50	2	S7395.0	
90°	5.00	5	15	50	2		S7405.0
60°	6.00	6	16	50	2	S7396.0	
90°	6.00	6	16	50	2		S7406.0
60°	8.00	8	20	64	2	S7398.0	
90°	8.00	8	20	64	2		S7408.0
60°	10.00	10	22	70	2	S73910.0	
90°	10.00	10	22	70	2		S74010.0
60°	12.00	12	25	75	2	S73912.0	
90°	12.00	12	25	75	2		S74012.0
60°	16.00	16	32	90	2	S73916.0	
90°	16.00	16	32	90	2		S74016.0
60°	20.00	20	38	100	2	S73920.0	
90°	20.00	20	38	100	2		S74020.0

S991

- Set frese in metallo duro
- Schafffräser, Satz
- VHM frezenset
- Coffret de fraises de finition, carbure monobloc

A=Tipi in serie, B=No. punte in Set, C=diametri in Set

A=Typen in Satz, B=Anzahl, C=Durchmesser im Satz

A=Type, B=Aantal, C=Diameters

A=Types de coffrets, B=Nombre dans le coffret, C=Diamètres dans le coffret



Nr.	A	B	C	S991
922	S922	6	Ø 3.00 mm, 4.00 mm, 5.00 mm, 6.00 mm, 8.00 mm, 10.00 mm	S991SET922
933	S933	6	Ø 3.00 mm, 4.00 mm, 5.00 mm, 6.00 mm, 8.00 mm, 10.00 mm	S991SET933
944	S944	6	Ø 3.00 mm, 4.00 mm, 5.00 mm, 6.00 mm, 8.00 mm, 10.00 mm	S991SET944

- C110** • Frese per cave
• Langlochfräser
- C126** • Spiebaanfrees
• Fraises à rainurer

C110	▪	1.1	1.2	4.1	5.1	6.1	6.2	6.3												
	•	1.3	1.4	2.1	3.1	3.2	3.3	3.4	4.2	5.2	7.1	7.2	7.3	8.1						
C126	▪	1.1	1.2	1.3	1.4	3.1	3.2	3.3	3.4	4.1	4.2	5.1	5.2	6.1	6.2	6.3				
	•	1.5	1.6	2.1	2.3	4.3	5.3	6.4	7.1	7.2	7.3	7.4	8.1							

C110	HSS-E PM		N	Z 2		$\lambda 30^\circ$ $\gamma 12^\circ$	DIN 1835B		e8		DIN 327D
C126	HSS-E PM		N	Z 2		$\lambda 30^\circ$ $\gamma 12^\circ$	DIN 1835B	TiCN	e8		DIN 327D

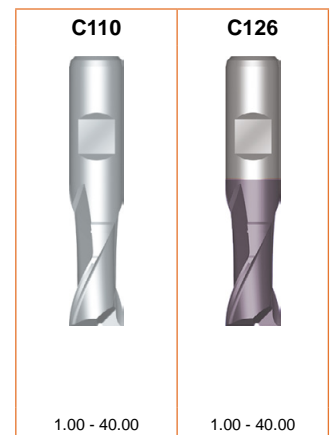
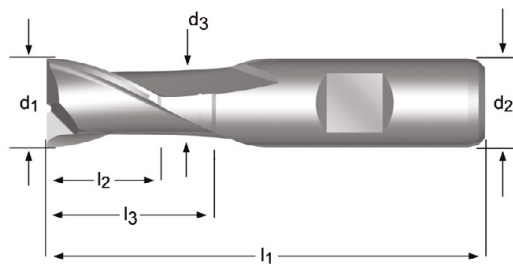

d ₁ Ø Inch	d ₁ Ø mm	d ₂ Øh ₆ mm	l ₂ mm	l ₁ mm	z	l ₃ mm	d ₃ Ø mm	C110	C126
	1.00	6	2.5	47	2	-	-	C1101.0	C1261.0
	1.50	6	3	47	2	-	-	C1101.5	C1261.5
1/16	1.59	6	3	47	2	-	-	C1101/16	
	1.80	6	4	48	2	-	-	C1101.8	
	2.00	6	4	48	2	-	-	C1102.0	C1262.0
3/32	2.38	6	5	49	2	-	-	C1103/32	
	2.50	6	5	49	2	-	-	C1102.5	C1262.5
	2.80	6	5	49	2	-	-	C1102.8	
	3.00	6	5	49	2	-	-	C1103.0	C1263.0
1/8	3.18	6	6	50	2	-	-	C1101/8	
	3.50	6	6	50	2	-	-	C1103.5	C1263.5
	3.80	6	7	51	2	-	-	C1103.8	
	4.00	6	7	51	2	-	-	C1104.0	C1264.0
	4.50	6	7	51	2	-	-	C1104.5	C1264.5
3/16	4.76	6	8	52	2	-	-	C1103/16	
	4.80	6	8	52	2	-	-	C1104.8	¹⁾²⁾
	5.00	6	8	52	2	-	-	C1105.0	C1265.0
	5.50	6	8	52	2	-	-	C1105.5	C1265.5
	5.75	6	8	52	2	-	-	C1105.75	¹⁾²⁾
	6.00	6	8	52	2	-	-	C1106.0	C1266.0
1/4	6.35	10	10	60	2	-	-	C1101/4	
	6.50	10	10	60	2	-	-	C1106.5	C1266.5
	7.00	10	10	60	2	-	-	C1107.0	C1267.0
	7.50	10	10	60	2	-	-	C1107.5	C1267.5
	7.75	10	11	61	2	-	-	C1107.75	¹⁾²⁾
5/16	7.94	10	11	61	2	-	-	C1105/16	
	8.00	10	11	61	2	-	-	C1108.0	C1268.0

¹⁾ Tolleranza sul diametro h10 / Durchmesser-Toleranz h10 / Diameter tolerantie h10 / tolérance sur le diamètre h10

²⁾ ≠ tolleranza P9 / ≠ P9 Toleranz / ≠ P9 tolerantie / ≠ P9 tolérance

d ₁ Ø Inch	d ₁ Ø mm	d ₂ Øh ₆ mm	l ₂ mm	l ₁ mm	z	l ₃ mm	d ₃ Ø mm	C110	C126
	8.50	10	11	61	2	-	-	C1108.5	C1268.5
	9.00	10	11	61	2	-	-	C1109.0	C1269.0
	9.50	10	11	61	2	-	-	C1109.5	C1269.5
3/8	9.52	10	13	63	2	22.5	9.5	C1103/8	
	10.00	10	13	63	2	22.5	9.5	C11010.0	C12610.0
13/32	10.32	12	13	70	2	-	-	C11013/32	
	10.50	12	13	70	2	-	-	C11010.5	C12610.5
	11.00	12	13	70	2	-	-	C11011.0	C12611.0
7/16	11.11	12	13	70	2	-	-	C1107/16	
	11.50	12	13	70	2	-	-	C11011.5	C12611.5
	12.00	12	16	73	2	27.5	11.5	C11012.0	C12612.0
	12.50	12	16	73	2	27.5	11.5	C11012.5	C12612.5
1/2	12.70	12	16	73	2	27.5	11.5	C1101/2	
	13.00	12	16	73	2	27.5	11.5	C11013.0	C12613.0
17/32	13.49	12	16	73	2	27.5	11.5	C11017/32	
	14.00	12	16	73	2	27.5	11.5	C11014.0	C12614.0
9/16	14.29	12	16	73	2	27.5	11.5	C1109/16	
	15.00	12	16	73	2	27.5	11.5	C11015.0	C12615.0
5/8	15.88	16	19	79	2	30.5	15.5	C1105/8	
	16.00	16	19	79	2	30.5	15.5	C11016.0	C12616.0
	17.00	16	19	79	2	30.5	15.5	C11017.0	
11/16	17.46	16	19	79	2	30.5	15.5	C11011/16	
	18.00	16	19	79	2	30.5	15.5	C11018.0	C12618.0
	19.00	16	19	79	2	30.5	15.5	C11019.0	
3/4	19.05	20	22	88	2	37.5	18.5	C1103/4	
	20.00	20	22	88	2	37.5	19.5	C11020.0	C12620.0
	22.00	20	22	88	2	37.5	19.5	C11022.0	C12622.0
7/8	22.22	20	22	88	2	37.5	19.5	C1107/8	
	24.00	25	26	102	2	45.5	23.5	C11024.0	C12624.0
	25.00	25	26	102	2	45.5	24.5	C11025.0	C12625.0
1"	25.40	25	26	102	2	45.5	24.5	C1101	
	26.00	25	26	102	2	45.5	24.5	C11026.0	
	28.00	25	26	102	2	45.5	24.5	C11028.0	
	30.00	25	26	102	2	45.5	24.5	C11030.0	C12630.0
	32.00	32	32	112	2	51.5	31.5	C11032.0	
	35.00	32	32	112	2	51.5	31.5	C11035.0	¹⁾³⁾
	36.00	32	32	112	2	51.5	31.5	C11036.0	¹⁾³⁾
	40.00	40	38	130	2	59.5	39.0	C11040.0	¹⁾³⁾

¹⁾ Tolleranza sul diametro h10 / Durchmesser-Toleranz h10 / Diameter tolerantie h10 / tolérance sur le diamètre h10

²⁾ ± tolleranza P9 / ± P9 Toleranz / ± P9 tolerantie / ± P9 tolérance

³⁾ Disponibile solo in HSCo / nur in HSCo / Alleen in HSCo leverbaar / Disponible en HSCo seulement

- C123** • Frese per cave
• Langlochfräser
- C139** • Spiebaanfrees
• Fraises à rainurer

C123	▪	1.1	1.2	1.3	1.4	4.1	5.1	6.1	6.2	6.3						
	•	2.1	3.1	3.2	3.3	3.4	4.2	5.2	7.1	7.2	7.3	8.1				
C139	▪	1.1	1.2	1.3	1.4	3.1	3.2	3.3	3.4	4.1	4.2	5.1	5.2	6.1	6.2	6.3
	•	1.5	1.6	2.1	2.3	4.3	5.3	6.4	7.1	7.2	7.3	7.4	8.1			

C123	HSS-E PM		N	Z 2		$\lambda 30^\circ$ $\gamma 12^\circ$	DIN 1835B		e8		DIN 844K
C139	HSS-E PM		N	Z 2		$\lambda 30^\circ$ $\gamma 12^\circ$	DIN 1835B	TiCN	e8		DIN 844K

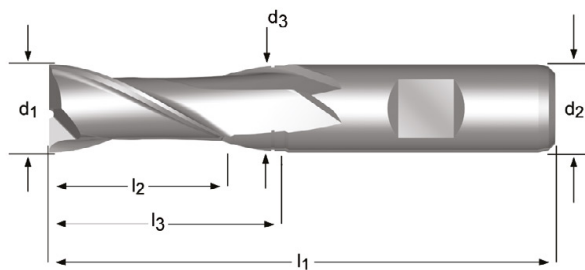

d ₁ Ø Inch	d ₁ Ø mm	d ₂ Ø _{h₆} mm	l ₂ mm	l ₁ mm	z	l ₃ mm	d ₃ Ø mm	C123	C139
1/16	1.59	6	7	51	2	-	-	C1231/16	¹⁾
	2.00	6	7	51	2	-	-	C1232.0	C1392.0
	2.50	6	8	52	2	-	-	C1232.5	
1/8	3.00	6	8	52	2	-	-	C1233.0	C1393.0
	3.18	6	10	54	2	-	-	C1231/8	¹⁾
5/32	3.50	6	10	54	2	-	-	C1233.5	
	3.97	6	11	55	2	-	-	C1235/32	¹⁾
3/16	4.00	6	11	55	2	-	-	C1234.0	C1394.0
	4.50	6	11	55	2	-	-	C1234.5	
	4.76	6	13	57	2	-	-	C1233/16	¹⁾
1/4	5.00	6	13	57	2	-	-	C1235.0	C1395.0
	5.50	6	13	57	2	-	-	C1235.5	C1395.5
	6.00	6	13	57	2	-	-	C1236.0	C1396.0
	6.35	10	16	66	2	-	-	C1231/4	¹⁾
5/16	6.50	10	16	66	2	-	-	C1236.5	C1396.5
	7.00	10	16	66	2	-	-	C1237.0	C1397.0
	7.50	10	16	66	2	-	-	C1237.5	C1397.5
	7.94	10	19	69	2	-	-	C1235/16	¹⁾
	8.00	10	19	69	2	-	-	C1238.0	C1398.0
3/8	8.50	10	19	69	2	-	-	C1238.5	C1398.5
	9.00	10	19	69	2	-	-	C1239.0	C1399.0
	9.50	10	19	69	2	-	-	C1239.5	C1399.5
	9.52	10	22	72	2	31.5	9.5	C1233/8	¹⁾
	10.00	10	22	72	2	31.5	9.5	C12310.0	C13910.0
	11.00	12	22	79	2	-	-	C12311.0	C13911.0
1/2	12.00	12	26	83	2	37.5	11.5	C12312.0	C13912.0
	12.70	12	26	83	2	37.5	11.5	C1231/2	¹⁾
	13.00	12	26	83	2	37.5	11.5	C12313.0	C13913.0

¹⁾ Tolleranza sul diametro -0,0005 / -0,0013 pollici / Durchmesser-Toleranz -.0005 inches / -.0013 inches / Diametertolerantie -.0005" / -.0013" / tolérance sur le diamètre -.0005 inches / -.0013 inches

d_1 Ø Inch	d_1 Ø mm	d_2 Ø _{h₆} mm	l_2 mm	l_1 mm	z	l_3 mm	d_3 Ø mm	C123	C139
	14.00	12	26	83	2	37.5	11.5	C12314.0	C13914.0
	15.00	12	26	83	2	37.5	11.5	C12315.0	C13915.0
	16.00	16	32	92	2	43.5	15.5	C12316.0	C13916.0
	18.00	16	32	92	2	43.5	15.5	C12318.0	C13918.0
	20.00	20	38	104	2	53.5	19.5	C12320.0	C13920.0
	22.00	20	38	104	2	53.5	19.5	C12322.0	C13922.0
	25.00	25	45	121	2	64.5	24.5	C12325.0	C13925.0
	30.00	25	45	121	2	64.5	24.5	C12330.0	

¹⁾ Tolleranza sul diametro -0,0005 / -0,0013 pollici / Durchmesser-Toleranz -0.0005 inches / -0.0013 inches / Diameter tolerantie -0,0005" / -0,0013" / tolérance sur le diamètre -0.0005 inches / -0.0013 inches

²⁾ Tolleranza sul diametro -0,0005 / -0,0015 pollici / Durchmesser-Toleranz -0.0005 inches / -0.0015 inches / Diameter tolerantie -0,0005" / -0,0015" / tolérance sur le diamètre -0.0005 inches / -0.0015 inches

³⁾ Disponibile solo in HSCo / nur in HSCo / Alleen in HSCo leverbaar / Disponible en HSCo seulement

C135

- Frese per cave
- Langlochfräser
- Spiebaanfrees
- Fraises à rainurer

C135	▪	1.1	1.2	5.1	6.1	6.2	6.3								
	•	1.3	1.4	2.1	3.1	3.2	3.3	3.4	4.1	4.2	5.2	7.1	7.2	7.3	8.1

C135 HSS-E P9 N Z 2 λ 30° γ 12° DIN 1835B e8 DORMER

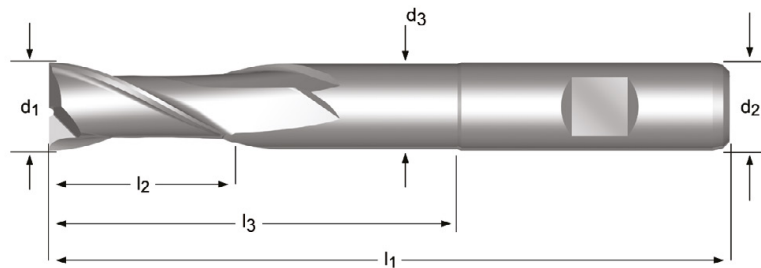

d_1 Ø mm	d_2 Ø _{h6} mm	l_2 mm	l_1 mm	z	l_3 mm	d_3 Ø mm	C135
2.00	6	7	54	2	18.0	1.8	C1352.0
3.00	6	8	56	2	20.0	2.8	C1353.0
4.00	6	11	63	2	27.0	3.7	C1354.0
5.00	6	13	68	2	32.0	4.7	C1355.0
6.00	6	13	68	2	32.0	5.7	C1356.0
8.00	10	19	88	2	48.0	7.5	C1358.0
10.00	10	22	95	2	54.5	9.5	C13510.0
12.00	12	26	110	2	64.5	11.5	C13512.0
14.00	12	26	110	2	64.5	11.5	C13514.0
16.00	16	32	123	2	74.5	15.5	C13516.0
18.00	16	32	123	2	74.5	15.5	C13518.0
20.00	20	38	141	2	90.5	19.5	C13520.0

- C306** • Frese per cave
• Langlochfräser
- C353** • Spiebaanfrees
• Fraises à rainurer

C306	▪	1.2	1.3	4.1	5.1	6.1	6.2	6.3										
	•	1.1	1.4	2.1	3.1	3.2	3.3	3.4	4.2	5.2	7.2	7.3	8.1					
C353	▪	1.2	1.3	1.4	1.5	3.1	3.2	3.3	3.4	4.1	4.2	5.1	5.2	6.1	6.2	6.3		
	•	1.1	1.6	2.1	2.2	2.3	4.3	5.3	6.4	7.2	7.3	7.4	8.1					

C306	HSS-E PM		N	Z 3		$\lambda 30^\circ$ $\gamma 12^\circ$	DIN 1835B		e8 h10		DIN 327D
C353	HSS-E PM		N	Z 3		$\lambda 30^\circ$ $\gamma 12^\circ$	DIN 1835B	Alcrona	e8 h10		DIN 327D

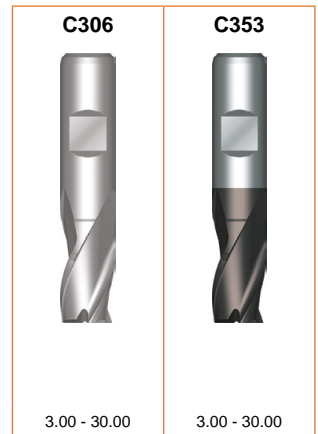
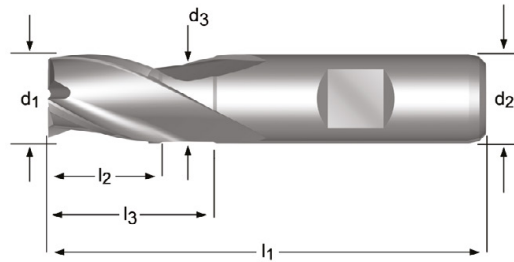

d_1 \emptyset mm	d_2 $\emptyset h_6$ mm	l_2 mm	l_1 mm	z	l_3 mm	d_3 \emptyset mm	C306	C353
3.00	6	5	49	3	-	-	C3063.0	C3533.0
3.50	6	6	50	3	-	-	-	C3533.5
4.00	6	7	51	3	-	-	C3064.0	C3534.0
4.50	6	7	51	3	-	-	-	C3534.5
4.80	6	8	52	3	-	-	-	C3534.8
5.00	6	8	52	3	-	-	C3065.0	C3535.0
5.50	6	8	52	3	-	-	-	C3535.5
6.00	6	8	52	3	-	-	C3066.0	C3536.0
6.50	10	10	60	3	-	-	-	C3536.5
7.00	10	10	60	3	-	-	C3067.0	C3537.0
7.50	10	10	60	3	-	-	-	C3537.5
7.75	10	11	61	3	-	-	-	C3537.75
8.00	10	11	61	3	-	-	C3068.0	C3538.0
8.50	10	11	61	3	-	-	-	C3538.5
9.00	10	11	61	3	-	-	C3069.0	C3539.0
9.50	10	11	61	3	-	-	C3069.5	C3539.5
10.00	10	13	63	3	22.5	9.5	C30610.0	C35310.0
11.00	12	13	70	3	-	-	C30611.0	C35311.0
12.00	12	16	73	3	27.5	11.5	C30612.0	C35312.0
13.00	12	16	73	3	27.5	11.5	-	C35313.0
14.00	12	16	73	3	27.5	11.5	C30614.0	C35314.0
15.00	12	16	73	3	27.5	11.5	C30615.0	C35315.0
16.00	16	19	79	3	30.5	15.5	C30616.0	C35316.0
18.00	16	19	79	3	30.5	15.5	C30618.0	C35318.0
20.00	20	22	88	3	37.5	19.5	C30620.0	C35320.0
22.00	20	22	88	3	37.5	19.5	C30622.0	C35322.0
25.00	25	26	102	3	45.5	24.5	C30625.0	C35325.0
28.00	25	26	102	3	45.5	24.5	-	C35328.0
30.00	25	26	102	3	45.5	24.5	C30630.0	C35330.0

C367

- Frese per cave
- Langlochfräser
- Spiebaanfrees
- Fraises à rainurer

C367	▪	1.1	1.2	2.1	2.2	2.3	2.4	6.1	7.1	
	•	1.3	1.4	4.1	5.1	6.2	6.3	7.2	7.3	8.1

C367 **HSS-E PM** **P9** **N** **Z 3** **λ 40°** **γ 15°** **DIN 1835B** **Alcrona** **e8** **DIN 327D**

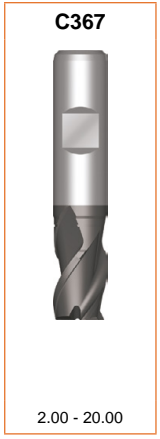
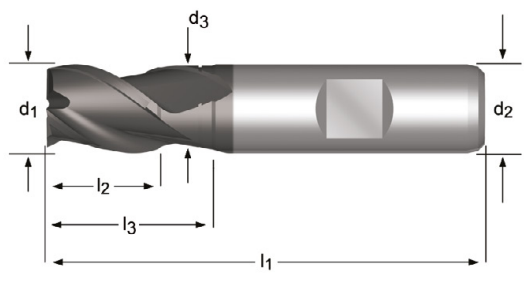

d_1 Ø mm	d_2 Ø mm	l_2 mm	l_1 mm	z	l_3 mm	d_3 Ø mm	C367
2.00	6	4	48	3	-	-	C3672.0
3.00	6	5	49	3	-	-	C3673.0
4.00	6	7	51	3	-	-	C3674.0
5.00	6	8	52	3	-	-	C3675.0
6.00	6	8	52	3	-	-	C3676.0
7.00	10	10	60	3	-	-	C3677.0
8.00	10	11	61	3	-	-	C3678.0
10.00	10	13	63	3	22.5	9.5	C36710.0
11.00	12	13	70	3	-	-	C36711.0
12.00	12	16	73	3	27.5	11.5	C36712.0
14.00	12	16	73	3	27.5	11.5	C36714.0
16.00	16	19	79	3	30.5	15.5	C36716.0
18.00	16	19	79	3	30.5	15.5	C36718.0
20.00	20	22	88	3	37.5	19.5	C36720.0

- C305** • Frese per cave
• Langlochfräser
- C352** • Spiebaanfrees
• Fraises à rainurer

C305	▪	1.2	1.3	4.1	5.1	5.2	6.1	6.2	6.3									
	•	1.1	1.4	2.1	3.1	3.2	3.3	3.4	4.2	7.2	7.3	8.1						
C352	▪	1.2	1.3	1.4	1.5	3.1	3.2	3.3	3.4	4.1	4.2	5.1	5.2	6.1	6.2	6.3		
	•	1.1	1.6	2.1	2.2	2.3	4.3	5.3	6.4	7.2	7.3	7.4	8.1					

C305	HSS-E PM		N	Z 3		λ 30° γ 12°	DIN 1835B		e8		DIN 844K
C352	HSS-E PM		N	Z 3		λ 30° γ 12°	DIN 1835B	Alcrona	e8		DIN 844K

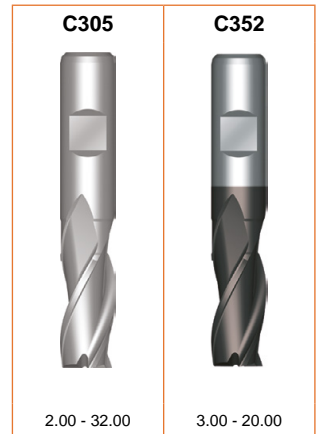
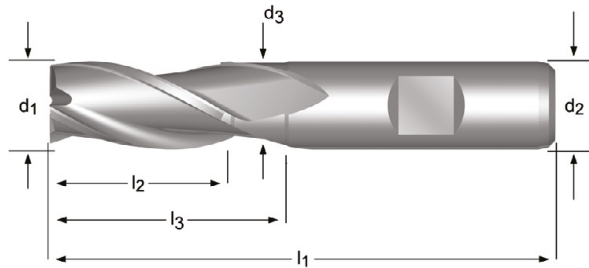

d_1 Ø mm	d_2 Ø _{h6} mm	l_2 mm	l_1 mm	z	l_3 mm	d_3 Ø mm	C305	C352
2.00	6	7	51	3	-	-	C3052.0	
2.50	6	8	52	3	-	-	C3052.5	
3.00	6	8	52	3	-	-	C3053.0	C3523.0
3.50	6	10	54	3	-	-	C3053.5	
4.00	6	11	55	3	-	-	C3054.0	C3524.0
4.50	6	11	55	3	-	-	C3054.5	
5.00	6	13	57	3	-	-	C3055.0	C3525.0
5.50	6	13	57	3	-	-	C3055.5	
6.00	6	13	57	3	-	-	C3056.0	C3526.0
6.50	10	16	66	3	-	-	C3056.5	
7.00	10	16	66	3	-	-	C3057.0	
7.50	10	16	66	3	-	-	C3057.5	
8.00	10	19	69	3	-	-	C3058.0	C3528.0
8.50	10	19	69	3	-	-	C3058.5	
9.00	10	19	69	3	-	-	C3059.0	
10.00	10	22	72	3	31.5	9.5	C30510.0	C35210.0
11.00	12	22	79	3	-	-	C30511.0	
12.00	12	26	83	3	37.5	11.5	C30512.0	C35212.0
13.00	12	26	83	3	37.5	11.5	C30513.0	
14.00	12	26	83	3	37.5	11.5	C30514.0	C35214.0
15.00	12	26	83	3	37.5	11.5	C30515.0	
16.00	16	32	92	3	43.5	15.5	C30516.0	C35216.0
17.00	16	32	92	3	43.5	15.5	C30517.0	
18.00	16	32	92	3	43.5	15.5	C30518.0	C35218.0
19.00	16	32	92	3	43.5	15.5	C30519.0	
20.00	20	38	104	3	53.5	19.5	C30520.0	C35220.0
22.00	20	38	104	3	53.5	19.5	C30522.0	
25.00	25	45	121	3	-	-	C30525.0	
28.00	25	45	121	3	-	-	C30528.0	
30.00	25	45	121	3	-	-	C30530.0	
32.00	32	53	133	3	-	-	C30532.0	

C159

- Frese per cave
- Langlochfräser
- Spiebaanfrees
- Fraises à rainurer

C159	▪	1.1	6.1	6.2	6.3	7.1	7.2	7.3	8.1	8.2
	•	1.2	1.3	2.1	2.2	4.1	5.1			

C159 HSS-E P9 W Z 2 $\lambda 40^\circ$ $\gamma 20^\circ$ DIN 1835B e8 DIN 844K

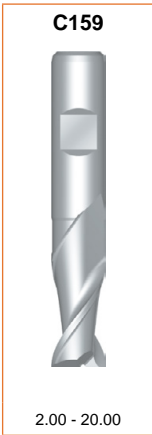
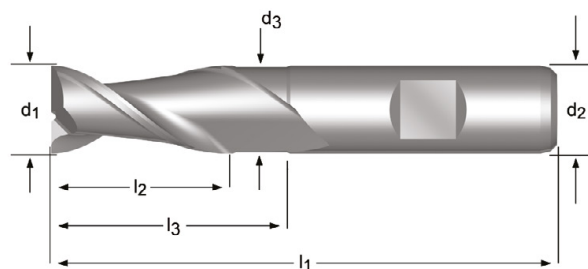

d_1 \varnothing mm	d_2 \varnothing_{h_6} mm	l_2 mm	l_1 mm	z	l_3 mm	d_3 \varnothing mm	C159
2.00	6	7	51	2	-	-	C1592.0
3.00	6	8	52	2	-	-	C1593.0
4.00	6	11	55	2	-	-	C1594.0
5.00	6	13	57	2	-	-	C1595.0
6.00	6	13	57	2	-	-	C1596.0
8.00	10	19	69	2	-	-	C1598.0
10.00	10	22	72	2	-	-	C15910.0
12.00	12	26	83	2	-	-	C15912.0
14.00	12	26	83	2	37.5	11.5	C15914.0
16.00	16	32	92	2	43.5	15.5	C15916.0
18.00	16	32	92	2	43.5	15.5	C15918.0
20.00	20	38	104	2	53.5	19.5	C15920.0

- C336**
- Frese
 - Schaftfräser
 - Vingerfreese
 - Fraises de finition

C336	▪	6.1	6.2	6.3	7.1	7.2	7.3	8.1	8.2
	•	1.1	1.2	1.3	2.1	2.2	4.1	5.1	

C336 HSS-E PM W Z 3 $\lambda 40^\circ$ $\gamma 25^\circ$ DIN 1835B k10 DIN 844K

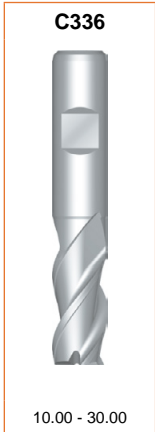
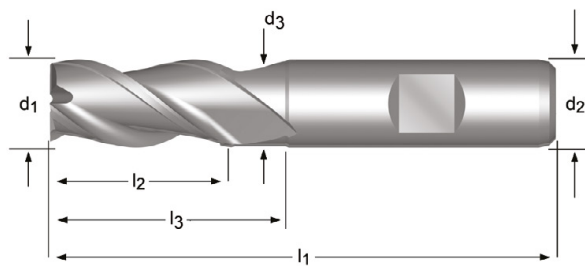

d_1 Ø mm	d_2 Ø _{h6} mm	l_2 mm	l_1 mm	z	l_3 mm	d_3 Ø mm	C336
10.00	10	22	72	3	31.5	9.5	C33610.0
12.00	12	26	83	3	37.5	11.5	C33612.0
14.00	12	26	83	3	37.5	11.5	C33614.0
16.00	16	32	92	3	43.5	15.5	C33616.0
18.00	16	32	92	3	43.5	15.5	C33618.0
20.00	20	38	104	3	53.5	19.5	C33620.0
22.00	20	38	104	3	53.5	19.5	C33622.0
25.00	25	45	121	3	64.5	24.5	C33625.0
30.00	25	45	121	3	64.5	24.5	C33630.0

C167

- Frese
- Schafffräser
- Vingerfrees
- Fraises de finition

C167	▪	1.1	1.2	5.1	6.1	6.2	6.3								
	•	1.3	1.4	2.1	3.1	3.2	3.3	3.4	4.1	4.2	5.2	7.1	7.2	7.3	8.1

C167 HSS-E N Z 2 $\lambda 30^\circ$ $\gamma 12^\circ$ js14

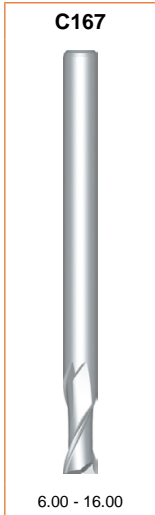
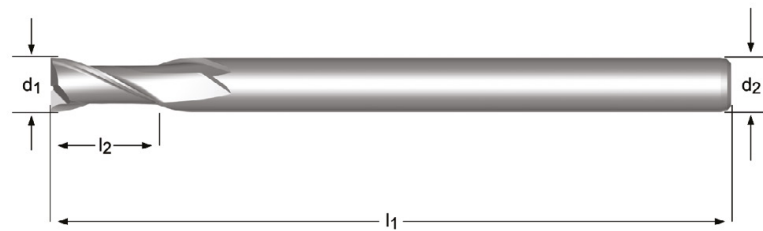

d_1 Ø mm	d_2 Ø _{h6} mm	l_2 mm	l_1 mm	z	C167
6.00	6	13	180	2	C1676.0
8.00	8	19	180	2	C1678.0
10.00	10	22	200	2	C16710.0
12.00	12	26	200	2	C16712.0
16.00	16	32	200	2	C16716.0

C122

- Frese
- Schaftfräser
- Vingerfreies
- Fraises de finition

C122	▪	1.1	1.2	5.1	6.1	6.2	6.3											
	•	1.3	1.4	2.1	3.1	3.2	3.3	3.4	4.1	4.2	5.2	7.1	7.2	7.3	8.1			

C122 HSS-E N Z 2 λ 30° γ 12° DIN 1835A e8 DORMER

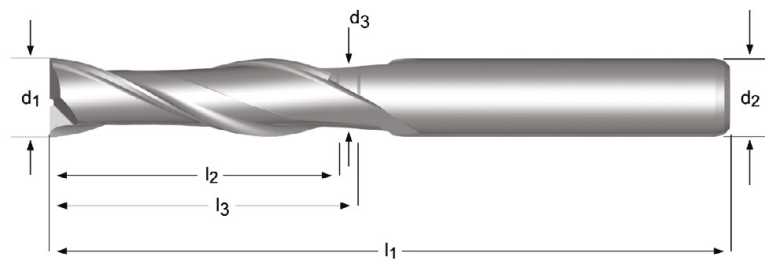

d_1 Ø mm	d_2 Ø _{h6} mm	l_2 mm	l_1 mm	z	l_3 mm	d_3 Ø mm	C122
5.00	5	22	65	2	-	-	C1225.0
6.00	6	27	75	2	-	-	C1226.0
7.00	8	33	85	2	-	-	C1227.0
8.00	8	33	85	2	-	-	C1228.0
10.00	10	40	95	2	-	-	C12210.0
12.00	12	45	110	2	-	-	C12212.0
14.00	12	52	125	2	-	-	C12214.0
16.00	16	58	140	2	69.5	15.5	C12216.0
18.00	16	65	150	2	76.5	15.5	C12218.0
20.00	20	70	160	2	85.5	19.5	C12220.0
22.00	20	75	170	2	90.5	19.5	C12222.0

C346

- Frese
- Schafffräser
- Vingerfrees
- Fraises de finition

C346	▪	1.2	4.1	5.1	6.1	6.2	6.3							
	•	1.1	1.3	1.4	2.1	3.1	3.2	3.3	3.4	4.2	5.2	7.1	7.2	8.1

C346 HSS-E N Z 3 $\lambda 30^\circ$ $\gamma 12^\circ$

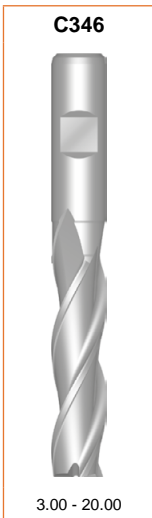
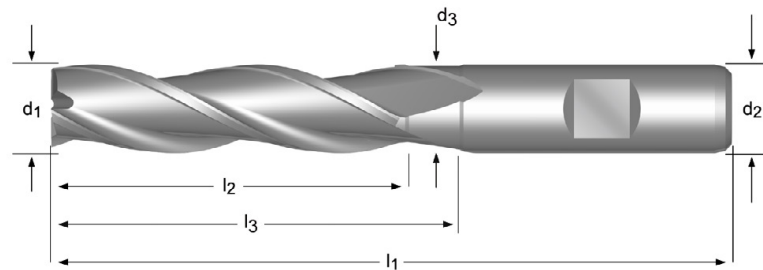

d_1 Ø mm	d_2 Ø _{h6} mm	l_2 mm	l_1 mm	z	l_3 mm	d_3 Ø mm	C346
3.00	6	12	56	3	-	-	C3463.0
4.00	6	19	63	3	-	-	C3464.0
5.00	6	24	68	3	-	-	C3465.0
6.00	6	24	68	3	-	-	C3466.0
7.00	10	30	80	3	-	-	C3467.0
8.00	10	38	88	3	-	-	C3468.0
9.00	10	38	88	3	-	-	C3469.0
10.00	10	45	95	3	-	-	C34610.0
11.00	12	45	102	3	-	-	C34611.0
12.00	12	53	110	3	-	-	C34612.0
13.00	12	53	110	3	64.5	11.5	C34613.0
15.00	12	53	110	3	64.5	11.5	C34615.0
16.00	16	63	123	3	74.5	15.5	C34616.0
20.00	20	75	141	3	90.5	19.5	C34620.0

- C299** • Frese
• Schaftfräser
- C907** • Vingerfrees
• Fraises de finition

C299	▪	1.3	1.4	1.5	2.1	2.3	3.1	3.2	3.3	3.4	4.2	4.3	5.1	5.2	5.3	6.2	7.4		
	•	1.6	2.2	4.1															
C907	▪	1.3	1.4	1.5	1.6	2.1	2.2	2.3	3.1	3.2	3.3	3.4	4.2	4.3	5.1	5.2	5.3	6.2	7.4
	•	4.1																	

C299	HSS-E PM		N	Z 3-5		$\lambda 45^\circ$ $\gamma 12^\circ$	DIN 1835B			k10		DIN 844K
C907	HSS-E PM		N	Z 3-6		$\lambda 45^\circ$ $\gamma 12^\circ$	DIN 1835B		Alcra	k10		DIN 844K

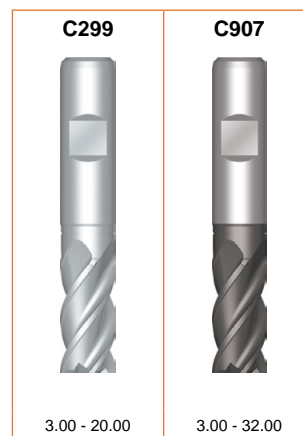
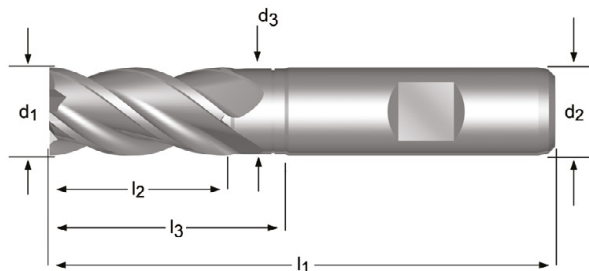

d_1 Ø mm	d_2 Ø _{h₆} mm	l_2 mm	l_1 mm	z	l_3 mm	d_3 Ø mm	C299	C907
3.00	6	8	52	3	-	-	C2993.0	C9073.0
4.00	6	11	55	3	-	-	C2994.0	C9074.0
5.00	6	13	57	3	-	-	C2995.0	C9075.0
6.00	6	13	57	3	-	-	C2996.0	C9076.0
8.00	10	19	69	4	-	-	C2998.0	C9078.0
10.00	10	22	72	4	31.5	9.5	C29910.0	C90710.0
12.00	12	26	83	4	37.5	11.5	C29912.0	C90712.0
14.00	12	26	83	4	37.5	11.5	C29914.0	C90714.0
16.00	16	32	92	4	43.5	15.5	C29916.0	C90716.0
18.00	16	32	92	4	43.5	15.5	C29918.0	C90718.0
20.00	20	38	104	4	53.5	19.5	C29920.0	C90720.0
22.00	20	38	104	5	53.5	19.5		C90722.0
28.00	25	45	121	6	64.5	24.5		C90728.0
30.00	25	45	121	6	64.5	24.5		C90730.0
32.00	32	53	133	6	72.5	31.5		C90732.0

C920

- Frese
- Schafffräser
- Vingerfrees
- Fraises de finition

C920 ■ 1.3 1.4 1.5 1.6 2.1 2.2 2.3 3.1 3.2 3.3 3.4 4.2 4.3 5.1 5.2 5.3 6.2 7.4
 • 4.1

C920 HSS-E PM N Z 3-5 $\lambda 45^\circ$ $\gamma 12^\circ$ DIN 1835B Alcrona k10 DIN 844L

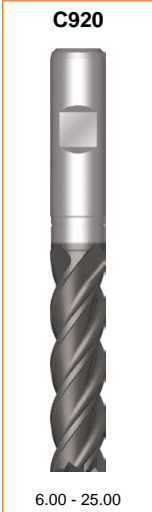
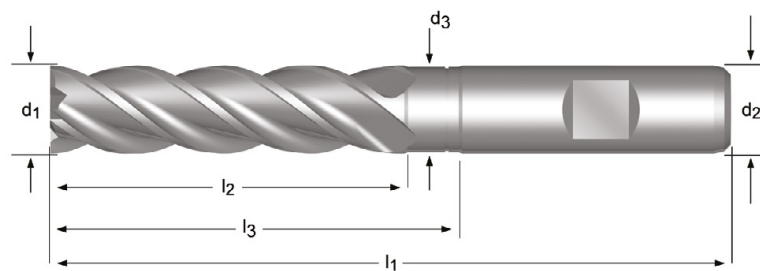

d_1 Ø mm	d_2 Ø _{h6} mm	l_2 mm	l_1 mm	z	l_3 mm	d_3 Ø mm	C920
6.00	6	24	68	3	-	-	C9206.0
8.00	10	38	88	4	-	-	C9208.0
10.00	10	45	95	4	54.5	9.5	C92010.0
12.00	12	53	110	4	64.5	11.5	C92012.0
14.00	12	53	110	4	64.5	11.5	C92014.0
16.00	16	63	123	4	74.5	15.5	C92016.0
18.00	16	63	123	4	74.5	15.5	C92018.0
20.00	20	75	141	4	90.5	19.5	C92020.0
22.00	20	75	141	5	90.5	19.5	C92022.0
25.00	25	90	166	5	109.5	24.5	C92025.0

C247 • Frese
• Schaftfräser

C246 • Vingerfrees
• Fraises de finition

C247	▪	1.1	1.2	1.3	4.1	5.1	6.1	6.2	6.3							
	•	1.4	2.1	3.1	3.2	3.3	3.4	4.2	5.2	7.1	7.2	7.3	8.1			
C246	▪	1.1	1.2	1.3	1.4	3.1	3.2	3.3	3.4	4.1	4.2	5.1	5.2	6.1	6.2	6.3
	•	1.5	1.6	2.1	2.3	4.3	5.3	6.4	7.1	7.2	7.3	7.4	8.1			

C247	HSS-E PM		N	Z 4-8		$\lambda 30^\circ$ $\gamma 12^\circ$	DIN 1835B		k10		DIN 844K
C246	HSS-E PM		N	Z 4-6		$\lambda 30^\circ$ $\gamma 12^\circ$	DIN 1835B	TiCN	k10		DIN 844K

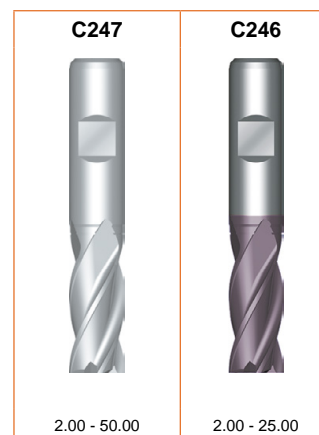
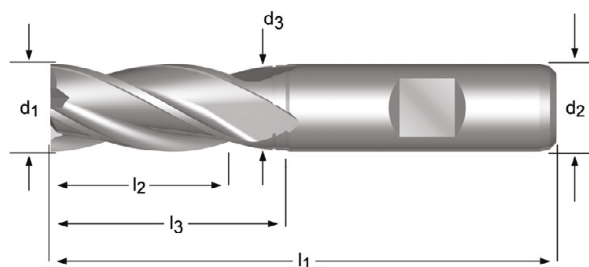

d ₁ Ø Inch	d ₁ Ø mm	d ₂ Ø _{h₆} mm	l ₂ mm	l ₁ mm	z	l ₃ mm	d ₃ Ø mm	C247	C246
	2.00	6	7	51	4	-	-	C2472.0	C2462.0
	2.50	6	8	52	4	-	-	C2472.5	
	3.00	6	8	52	4	-	-	C2473.0	C2463.0
1/8	3.18	6	10	54	4	-	-	C2471/8 ¹⁾	
	3.50	6	10	54	4	-	-	C2473.5	
	4.00	6	11	55	4	-	-	C2474.0	C2464.0
	4.50	6	11	55	4	-	-	C2474.5	
3/16	4.76	6	13	57	4	-	-	C2473/16 ¹⁾	
	5.00	6	13	57	4	-	-	C2475.0	C2465.0
	5.50	6	13	57	4	-	-	C2475.5	
	6.00	6	13	57	4	-	-	C2476.0	C2466.0
1/4	6.35	10	16	66	4	-	-	C2471/4 ¹⁾	
	6.50	10	16	66	4	-	-	C2476.5	
	7.00	10	16	66	4	-	-	C2477.0	C2467.0
	7.50	10	16	66	4	-	-	C2477.5	
5/16	7.94	10	19	69	4	-	-	C2475/16 ¹⁾	
	8.00	10	19	69	4	-	-	C2478.0	C2468.0
	8.50	10	19	69	4	-	-	C2478.5	
	9.00	10	19	69	4	-	-	C2479.0	
	9.50	10	19	69	4	-	-	C2479.5	
3/8	9.52	10	22	72	4	31.5	9.5	C2473/8 ¹⁾	
	10.00	10	22	72	4	31.5	9.5	C24710.0	C24610.0
	11.00	12	22	79	4	-	-	C24711.0	C24611.0
	12.00	12	26	83	4	37.5	11.5	C24712.0	C24612.0
1/2	12.70	12	26	83	4	37.5	11.5	C2471/2 ¹⁾	
	13.00	12	26	83	4	37.5	11.5	C24713.0	C24613.0
	14.00	12	26	83	4	37.5	11.5	C24714.0	C24614.0
9/16	14.29	12	26	83	4	37.5	11.5	C2479/16 ¹⁾	
	15.00	12	26	83	4	37.5	11.5	C24715.0	C24615.0
5/8	15.88	16	32	92	4	43.5	15.5	C2475/8 ¹⁾	

¹⁾ Tolleranza sul diametro +0,0025 / -0,0005 pollici / Durchmesser-Toleranz +.0025 inches / -.0005 inches / Diameter tolerantie +0,0025" / -0,0005" / tolérance sur le diamètre +.0025 inches / -.0005 inches

d ₁ Ø Inch	d ₁ Ø mm	d ₂ Øh ₆ mm	l ₂ mm	l ₁ mm	z	l ₃ mm	d ₃ Ø mm	C247	C246
	16.00	16	32	92	4	43.5	15.5	C24716.0	C24616.0
	17.00	16	32	92	4	43.5	15.5	C24717.0	
	18.00	16	32	92	4	43.5	15.5	C24718.0	C24618.0
	19.00	16	32	92	4	43.5	15.5	C24719.0	
3/4	19.05	20	38	104	4	53.5	18.5	C2473/4	¹⁾
	20.00	20	38	104	4	53.5	19.5	C24720.0	C24620.0
	21.00	20	38	104	4	53.5	19.5	C24721.0	
	22.00	20	38	104	5	53.5	19.5	C24722.0	C24622.0
7/8	22.22	20	38	104	5	53.5	19.5	C2477/8	¹⁾
	23.00	20	38	104	5	53.5	19.5	C24723.0	
	24.00	25	45	121	5	64.5	23.5	C24724.0	
	25.00	25	45	121	5	64.5	24.5	C24725.0	C24625.0
1"	25.40	25	45	121	5	64.5	24.5	C2471	¹⁾
	26.00	25	45	121	6	64.5	24.5	C24726.0	
	28.00	25	45	121	6	64.5	24.5	C24728.0	
	30.00	25	45	121	6	64.5	24.5	C24730.0	
	32.00	32	53	133	6	72.5	31.5	C24732.0	
	36.00	32	53	133	6	72.5	31.5	C24736.0	²⁾³⁾
	40.00	40	63	155	6	84.5	39.0	C24740.0	²⁾³⁾
	50.00	50	75	177	8	96.5	48.0	C24750.0	²⁾³⁾

¹⁾ Tolleranza sul diametro +0,0025 / -0,0005 pollici / Durchmesser-Toleranz +.0025 inches / -.0005 inches / Diameter tolerantie +0,0025" / -0,0005" / tolérance sur le diamètre +.0025 inches / -.0005 inches

²⁾ senza tagliente al centro / kein Zentrumschnitt / Niet centrumsnijdend / Pas de coupe au centre

³⁾ Disponibile solo in HSCo / nur in HSCo / Alleen in HSCo leverbaar / Disponible en HSCo seulement

- C273** • Frese
• Schaftfräser
- C295** • Vingerfrees
• Fraises de finition

C273	▪	1.1	1.2	1.3	4.1	5.1	6.1	6.2	6.3											
	•	1.4	2.1	3.1	3.2	3.3	3.4	4.2	5.2	7.1	7.2	7.3	8.1							
C295	▪	1.1	1.2	1.3	1.4	3.1	3.2	3.3	3.4	4.1	4.2	5.1	5.2	6.1	6.2	6.3				
	•	1.5	1.6	2.1	2.3	4.3	5.3	6.4	7.1	7.2	7.3	7.4	8.1							

C273	HSS-E PM		N	Z 4-6		λ 30° γ 12°	DIN 1835B		k10			DIN 844L
C295	HSS-E PM		N	Z 4-6		λ 30° γ 12°	DIN 1835B		TiCN			DIN 844L

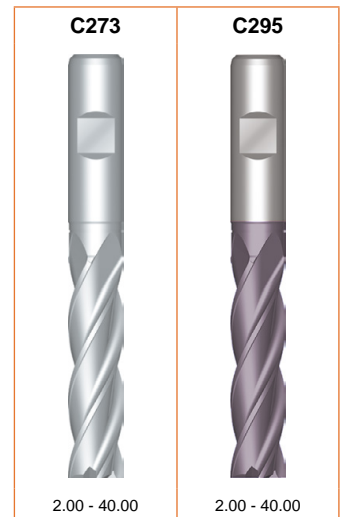
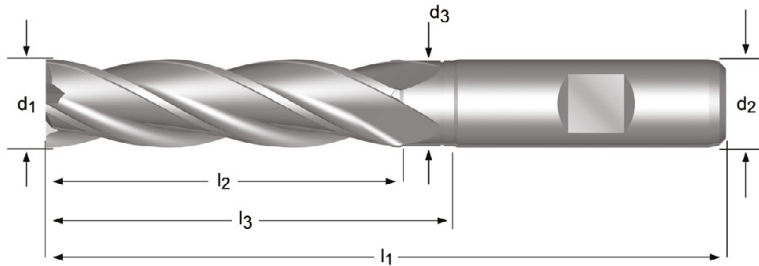

d_1 Ø Inch	d_1 Ø mm	d_2 Ø _{h6} mm	l_2 mm	l_1 mm	z	l_3 mm	d_3 Ø mm	C273	C295
	2.00	6	10	54	4	-	-	C2732.0	C2952.0
	2.50	6	12	56	4	-	-	C2732.5	
	3.00	6	12	56	4	-	-	C2733.0	C2953.0
1/8	3.18	6	15	59	4	-	-	C2731/8 ¹⁾	
	3.50	6	15	59	4	-	-	C2733.5	
	4.00	6	19	63	4	-	-	C2734.0	C2954.0
	4.50	6	19	63	4	-	-	C2734.5	
3/16	4.76	6	24	68	4	-	-	C2733/16 ¹⁾	
	5.00	6	24	68	4	-	-	C2735.0	C2955.0
	5.50	6	24	68	4	-	-	C2735.5	
	6.00	6	24	68	4	-	-	C2736.0	C2956.0
1/4	6.35	10	30	80	4	-	-	C2731/4 ¹⁾	
	7.00	10	30	80	4	-	-	C2737.0	C2957.0
	8.00	10	38	88	4	-	-	C2738.0	C2958.0
	9.00	10	38	88	4	-	-	C2739.0	C2959.0
3/8	9.52	10	45	95	4	54.5	9.5	C2733/8 ¹⁾	
	10.00	10	45	95	4	54.5	9.5	C27310.0	C29510.0
	11.00	12	45	102	4	-	-	C27311.0	C29511.0
	12.00	12	53	110	4	64.5	11.5	C27312.0	C29512.0
1/2	12.70	12	53	110	4	64.5	11.5	C2731/2 ¹⁾	
	13.00	12	53	110	4	64.5	11.5	C27313.0	
	14.00	12	53	110	4	64.5	11.5	C27314.0	
	15.00	12	53	110	4	64.5	11.5	C27315.0	C29515.0
5/8	15.88	16	63	123	4	74.5	15.5	C2735/8 ¹⁾	
	16.00	16	63	123	4	74.5	15.5	C27316.0	C29516.0
	18.00	16	63	123	4	74.5	15.5	C27318.0	C29518.0

¹⁾ Tolleranza sul diametro +0,0025 / -0,0005 pollici / Durchmesser-Toleranz +.0025 inches / -.0005 inches / Diameter tolerantie +0,0025" / -0,0005" / tolérance sur le diamètre +.0025 inches / -.0005 inches

d ₁ Ø Inch	d ₁ Ø mm	d ₂ Øh ₅ mm	l ₂ mm	l ₁ mm	z	l ₃ mm	d ₃ Ø mm	C273	C295
3/4	19.05	20	75	141	4	90.5	18.5	C2733/4 ¹⁾	
	20.00	20	75	141	4	90.5	19.5	C27320.0	C29520.0
	22.00	20	75	141	5	90.5	19.5	C27322.0	
	25.00	25	90	166	5	109.5	24.5	C27325.0	C29525.0
1"	25.40	25	90	166	5	109.5	24.5	C2731 ¹⁾	
	28.00	25	90	166	6	109.5	24.5	C27328.0	
	30.00	25	90	166	6	109.5	24.5	C27330.0	C29530.0
	32.00	32	106	186	6	125.5	31.5	C27332.0	C29532.0
	40.00	40	125	217	6	146.5	39.0	C27340.0 ²⁾³⁾	C29540.0

¹⁾ Tolleranza sul diametro +0,0025 / -0,0005 pollici / Durchmesser-Toleranz +.0025 inches / -.0005 inches / Diameter tolerantie +0,0025" / -0,0005" / tolérance sur le diamètre +.0025 inches / -.0005 inches

²⁾ Disponibile solo in HSCo / nur in HSCo / Alleen in HSCo leverbaar / Disponible en HSCo seulement

³⁾ senza tagliente al centro / kein Zentrumschnitt / Niet centrumsnijdend / Pas de coupe au centre

- C333**
- Frese
 - Schaftfräser
 - Vingerfreies
 - Fraises de finition

C333 ■ 6.1 6.2 6.3 7.1 7.2 7.3 8.1 8.2

C333 HSS-E PM W Z 3 λ 40° γ 25° DIN 1835B k10 DIN 844L

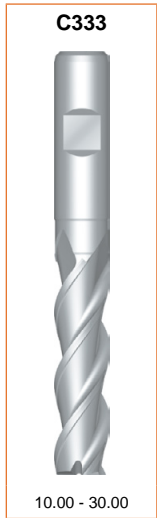
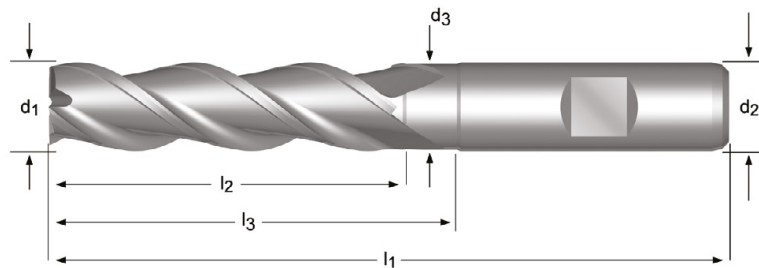

d_1 \emptyset mm	d_2 $\emptyset h_6$ mm	l_2 mm	l_1 mm	z	l_3 mm	d_3 \emptyset mm	C333
10.00	10	45	95	3	54.5	9.5	C33310.0
12.00	12	53	110	3	64.5	11.5	C33312.0
14.00	12	53	110	3	64.5	11.5	C33314.0
16.00	16	63	123	3	74.5	15.5	C33316.0
18.00	16	63	123	3	74.5	15.5	C33318.0
20.00	20	75	141	3	90.5	19.5	C33320.0
25.00	25	90	166	3	109.5	24.5	C33325.0
30.00	25	90	166	3	109.5	24.5	C33330.0

C922

- Frese a sgrossare
- Schruppfräser
- Ruwfrees
- Fraises d'ébauche

C922	▪	1.4	1.5	1.6	2.1	2.2	2.3	3.1	3.2	3.3	3.4	4.2	4.3	5.2	5.3	6.2	7.4
	•	1.3	4.1	5.1	6.4												

C922 **HSS-E PM** **HRA** **Z 3-4** $\lambda 35^\circ$ $\gamma 12^\circ$ **DIN 1835B** **Alcrona** **k12** **DIN 844K**

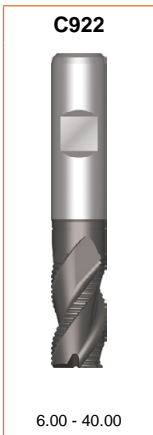
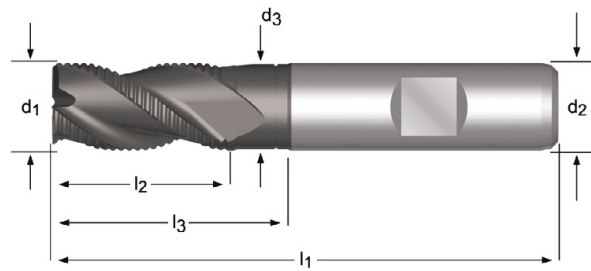

d_1 Ø mm	d_2 Ø _{h8} mm	l_2 mm	l_1 mm	z	l_3 mm	d_3 Ø mm	C922
6.00	6	13	57	3	-	-	C9226.0
7.00	10	16	66	3	-	-	C9227.0
8.00	10	19	69	3	-	-	C9228.0
9.00	10	19	69	3	-	-	C9229.0
10.00	10	22	72	3	31.5	9.5	C92210.0
11.00	12	22	79	3	-	-	C92211.0
12.00	12	26	83	3	37.5	11.5	C92212.0
13.00	12	26	83	3	37.5	11.5	C92213.0
14.00	12	26	83	3	37.5	11.5	C92214.0
15.00	12	26	83	3	37.5	11.5	C92215.0
16.00	16	32	92	3	43.5	15.5	C92216.0
18.00	16	32	92	3	43.5	15.5	C92218.0
20.00	20	38	104	3	53.5	19.5	C92220.0
22.00	20	38	104	3	53.5	19.5	C92222.0
24.00	25	45	121	4	64.5	23.5	C92224.0
25.00	25	45	121	4	64.5	24.5	C92225.0
28.00	25	45	121	4	64.5	24.5	C92228.0
32.00	32	53	133	4	72.5	31.5	C92232.0

C428

- Frese a grossare
- Schruppfräser
- Ruwfreies
- Fraises d'ébauche

C428	▪	1.4	1.5	1.6	2.1	2.2	2.3	3.1	3.2	3.3	3.4	4.2	4.3	5.2	5.3	6.2	7.4
	•	1.3	4.1	5.1	6.4												

C428 HSS-E PM HRA Z 4-6 $\lambda 35^\circ$ $\gamma 12^\circ$ DIN 1835B Alcrona k12 DIN 844K

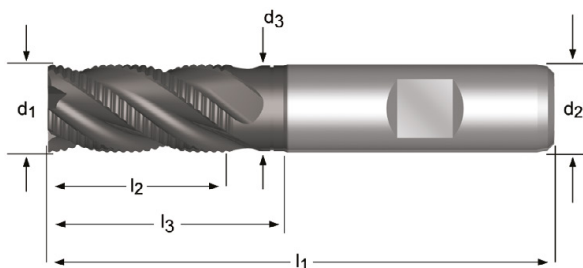

C428



6.00 - 40.00

d_1 Ø mm	d_2 Ø _{h6} mm	l_2 mm	l_1 mm	z	l_3 mm	d_3 Ø mm	C428
6.00	6	13	57	4	-	-	C4286.0
7.00	10	16	66	4	-	-	C4287.0
8.00	10	19	69	4	-	-	C4288.0
9.00	10	19	69	4	-	-	C4289.0
10.00	10	22	72	4	31.5	9.5	C42810.0
11.00	12	22	79	4	-	-	C42811.0
12.00	12	26	83	4	37.5	11.5	C42812.0
13.00	12	26	83	4	37.5	11.5	C42813.0
14.00	12	26	83	4	37.5	11.5	C42814.0
15.00	12	26	83	4	37.5	11.5	C42815.0
16.00	16	32	92	4	43.5	15.5	C42816.0
18.00	16	32	92	4	43.5	15.5	C42818.0
20.00	20	38	104	4	53.5	19.5	C42820.0
22.00	20	38	104	4	53.5	19.5	C42822.0
25.00	25	45	121	6	64.5	24.5	C42825.0
28.00	25	45	121	6	64.5	24.5	C42828.0
30.00	25	45	121	6	64.5	24.5	C42830.0
32.00	32	53	133	6	72.5	31.5	C42832.0
36.00	32	53	133	6	72.5	31.0	C42836.0
40.00	40	63	155	6	84.5	39.0	C42840.0

C492

- Frese a sgrossare
- Schruppfräser
- Ruwfrees
- Fraises d'ébauche

C492 ■ 1.3 1.4 1.5 1.6 2.1 2.2 2.3 3.1 3.2 3.3 3.4 4.2 4.3 5.2 5.3 6.2 7.4
 • 4.1 5.1 6.4

C492 HSS-E PM HRA Z 3-6 λ 35° γ 12° DIN 1835B Alcrona k12 DIN 844L

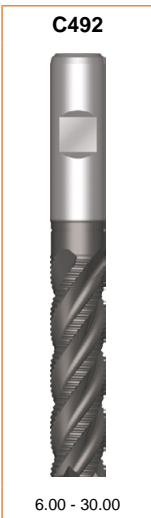
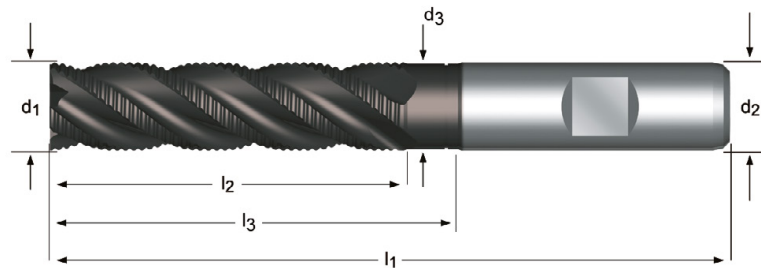

d_1 Ø mm	d_2 Ø _{h6} mm	l_2 mm	l_1 mm	z	l_3 mm	d_3 Ø mm	C492
6.00	6	24	68	3	-	-	C4926.0
8.00	10	38	88	3	-	-	C4928.0
10.00	10	45	95	4	54.5	9.5	C49210.0
12.00	12	53	110	4	64.5	11.5	C49212.0
14.00	12	53	110	4	64.5	11.5	C49214.0
16.00	16	63	123	4	74.5	15.5	C49216.0
18.00	16	63	123	4	74.5	15.5	C49218.0
20.00	20	75	141	4	90.5	19.5	C49220.0
22.00	20	75	141	4	90.5	19.5	C49222.0
25.00	25	90	166	6	109.5	24.5	C49225.0
30.00	25	90	166	6	109.5	24.5	C49230.0

C407 • Frese a sgrossare
• Schruppfräser

C908 • Ruwfreies
• Fraises d'ébauche

C407	▪	1.2	1.3	1.4	1.5	2.1	2.3	3.1	3.2	3.3	3.4	4.2	4.3	5.2	5.3	6.2	
	•	1.1	1.6	2.2	4.1	5.1	6.4	7.4									
C908	▪	1.3	1.4	1.5	2.1	2.2	2.3	3.1	3.2	3.3	3.4	4.2	4.3	5.2	5.3	6.2	
	•	1.6	4.1	5.1	6.4	7.4											

C407	HSS-E PM		NRA	Z 4-6		λ 35° γ 12°	DIN 1835B		Alcrona	k12		DIN 844K
C908	HSS-E PM		NRA	Z 4-6		λ 35° γ 12°	DIN 1835B		Alcrona	k12		DIN 844K

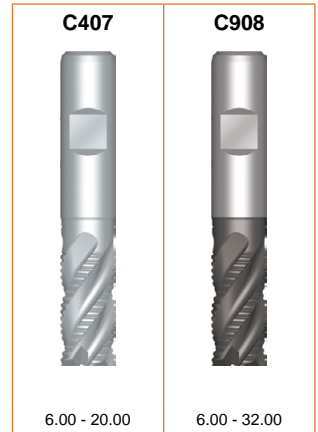
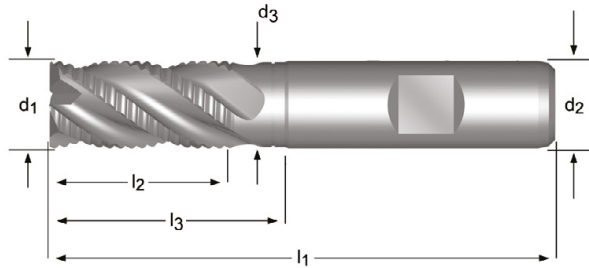

d_1 Ø mm	d_2 Ø _{h₅} mm	l_2 mm	l_1 mm	z	l_3 mm	d_3 Ø mm	C407	C908
6.00	6	13	57	4	-	-	C4076.0	C9086.0
7.00	10	16	66	4	-	-	C4077.0	C9087.0
8.00	10	19	69	4	-	-	C4078.0	C9088.0
9.00	10	19	69	4	-	-	C4079.0	C9089.0
10.00	10	22	72	4	31.5	9.5	C40710.0	C90810.0
11.00	12	22	79	4	-	-	C40711.0	C90811.0
12.00	12	26	83	4	37.5	11.5	C40712.0	C90812.0
13.00	12	26	83	4	37.5	11.5	C40713.0	C90813.0
14.00	12	26	83	4	37.5	11.5	C40714.0	C90814.0
15.00	12	26	83	4	37.5	11.5	C40715.0	C90815.0
16.00	16	32	92	4	43.5	15.5	C40716.0	C90816.0
18.00	16	32	92	4	43.5	15.5	C40718.0	C90818.0
20.00	20	38	104	4	53.5	19.5	C40720.0	C90820.0
22.00	20	38	104	4	53.5	19.5		C90822.0
25.00	25	45	121	6	64.5	24.5		C90825.0
30.00	25	45	121	6	64.5	24.5		C90830.0
32.00	32	53	133	6	72.5	31.5		C90832.0

C948

- Frese a sgrossare
- Schruppfräser
- Ruwfrees
- Fraises d'ébauche

C948 ■ 1.3 1.4 1.5 1.6 2.1 2.2 2.3 3.1 3.2 3.3 3.4 4.2 4.3 5.2 5.3 6.2 7.4
 • 4.1 5.1 6.4

C948 HSS-E PM NRA Z 4-6 λ 35° γ 12° DIN 1835B Alcrona k12 DIN 844L

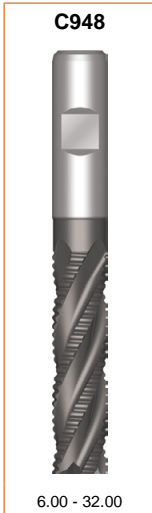
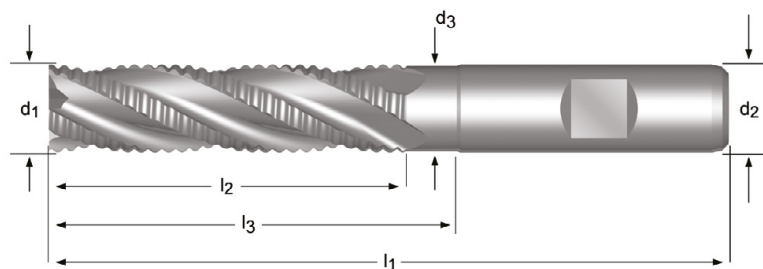

d ₁ Ø mm	d ₂ Ø _{h₆} mm	l ₂ mm	l ₁ mm	z	l ₃ mm	d ₃ Ø mm	C948
6.00	6	24	68	4	-	-	C9486.0
8.00	10	38	88	4	-	-	C9488.0
10.00	10	45	95	4	54.5	9.5	C94810.0
12.00	12	53	110	4	64.5	11.5	C94812.0
14.00	12	53	110	4	64.5	11.5	C94814.0
16.00	16	63	123	4	74.5	15.5	C94816.0
18.00	16	63	123	4	74.5	15.5	C94818.0
20.00	20	75	141	4	90.5	19.5	C94820.0
25.00	25	90	166	6	109.5	24.5	C94825.0
30.00	25	90	166	6	109.5	24.5	C94830.0
32.00	32	106	186	6	125.5	31.5	C94832.0

- C400** • Frese a sgrossare
• Schruppfräser
- C413** • Ruwfreies
• Fraises d'ébauche

C400	▪	1.2	1.3	6.2	6.3											
	•	1.1	1.4	2.1	3.1	3.2	3.3	3.4	4.1	4.2	5.1	5.2	6.1	7.2	7.3	8.1
C413	▪	1.2	1.3	1.4	3.1	3.2	3.3	3.4	4.2	5.2	6.2	6.3				
	•	1.1	1.5	1.6	2.1	2.3	4.1	4.3	5.1	5.3	6.1	6.4	7.2	7.3	7.4	8.1

C400	HSS-E		NF	Z 4-6		λ 30° γ 12°	DIN 1835B		k12		DIN 844K
C413	HSS-E		NF	Z 4-6		λ 30° γ 12°	DIN 1835B	TiCN	k12		DIN 844K

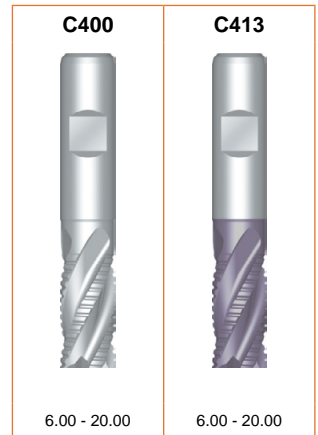
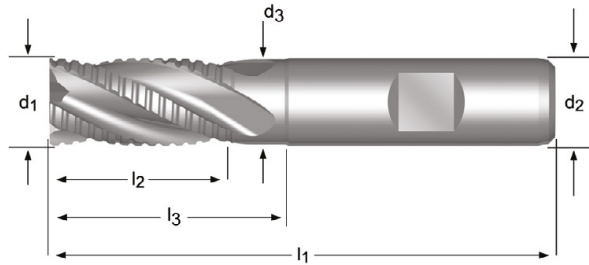

d_1 Ø mm	d_2 Ø _{h6} mm	l_2 mm	l_1 mm	z	l_3 mm	d_3 Ø mm	C400	C413
6.00	6	13	57	4	-	-	C4006.0	C4136.0
8.00	10	19	69	4	-	-	C4008.0	C4138.0
10.00	10	22	72	4	-	-	C40010.0	C41310.0
12.00	12	26	83	4	-	-	C40012.0	C41312.0
14.00	12	26	83	4	37.5	11.5	C40014.0	C41314.0
16.00	16	32	92	4	43.5	15.5	C40016.0	C41316.0
18.00	16	32	92	4	43.5	15.5	C40018.0	C41318.0
20.00	20	38	104	4	53.5	19.5	C40020.0	C41320.0

C403

- Frese a sgrossare
- Schruppfräser
- Ruwfreies
- Fraises d'ébauche

C403 ■ 1.2 1.3 6.2 6.3
 • 1.1 1.4 2.1 3.1 3.2 3.3 3.4 4.1 4.2 5.1 5.2 6.1 7.2 7.3 8.1

C403 HSS-E NF Z 4-6 $\lambda 30^\circ$ $\gamma 12^\circ$ DIN 1835B k12 DIN 844L

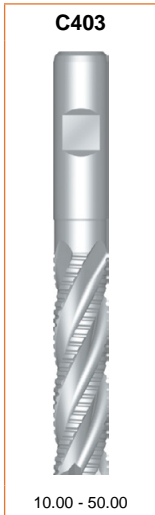
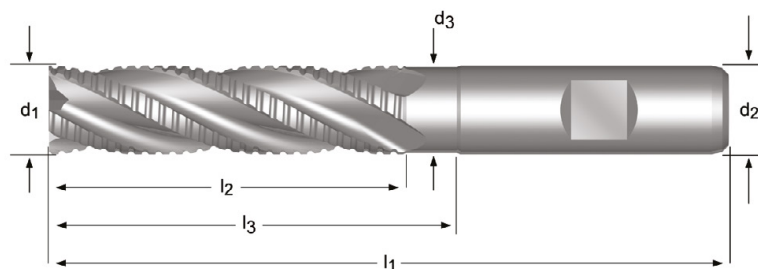

d_1 Ø mm	d_2 Ø _{h6} mm	l_2 mm	l_1 mm	z	l_3 mm	d_3 Ø mm	C403
10.00	10	45	95	4	-	-	C40310.0
12.00	12	53	110	4	-	-	C40312.0
14.00	12	53	110	4	64.5	11.5	C40314.0
16.00	16	63	123	4	74.5	15.5	C40316.0
18.00	16	63	123	4	74.5	15.5	C40318.0
20.00	20	75	141	4	90.5	19.5	C40320.0
30.00	25	90	166	5	109.5	24.5	C40330.0
32.00	32	106	186	6	125.5	31.0	C40332.0
36.00	32	106	186	6	125.5	31.5	C40336.0
40.00	40	125	217	6	146.5	39.0	C40340.0
45.00	40	125	217	6	146.5	39.5	C40345.0
50.00	50	150	252	6	171.5	48.0	C40350.0

- C500**
- Frese semisferiche
 - Radius - Kopierfräser
 - Radiusfreies
 - Fraises de finition bout hémisphérique

C500	▪	1.1	1.2	4.1	5.1	6.1	6.2	6.3							
	•	1.3	1.4	2.1	3.1	3.2	3.3	3.4	4.2	5.2	7.1	7.2	7.3	8.1	

C500 HSS-E  N  Z 2   $\lambda 30^\circ$ $\gamma 12^\circ$   

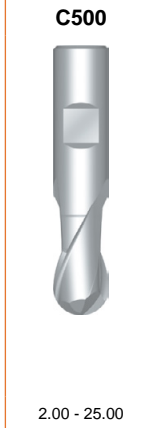
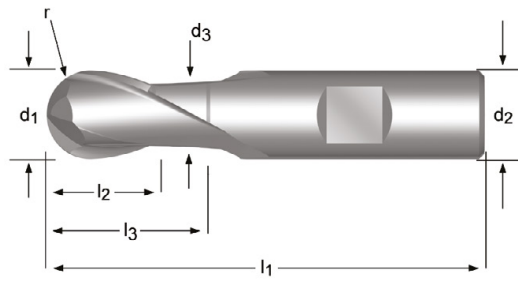

d_1 Ø mm	r ±0.05 mm	d_2 Ø _{h6} mm	l_2 mm	l_1 mm	z	l_3 mm	d_3 Ø mm	C500
2.00	1.00	6	4	48	2	-	-	C5002.0
3.00	1.50	6	5	49	2	-	-	C5003.0
4.00	2.00	6	7	51	2	-	-	C5004.0
5.00	2.50	6	8	52	2	-	-	C5005.0
6.00	3.00	6	8	52	2	-	-	C5006.0
7.00	3.50	10	10	60	2	-	-	C5007.0
8.00	4.00	10	11	61	2	-	-	C5008.0
9.00	4.50	10	11	61	2	-	-	C5009.0
10.00	5.00	10	13	63	2	-	-	C50010.0
12.00	6.00	12	16	73	2	-	-	C50012.0
14.00	7.00	12	16	73	2	27.5	11.5	C50014.0
15.00	7.50	12	16	73	2	27.5	11.5	C50015.0
16.00	8.00	16	19	79	2	30.5	15.5	C50016.0
18.00	9.00	16	19	79	2	30.5	15.5	C50018.0
20.00	10.00	20	22	88	2	37.5	19.5	C50020.0
25.00	12.50	25	26	102	2	45.5	24.5	C50025.0

- C505**
- Frese semisferiche
 - Radius - Kopierfräser
 - Radiusfrees
 - Fraises de finition bout hémisphérique

C505	▪	1.1	1.2	4.1	5.1	6.1	6.2	6.3										
	•	1.3	1.4	2.1	3.1	3.2	3.3	3.4	4.2	5.2	7.1	7.2	7.3	8.1				

C505 HSS-E N Z 2 $\lambda 30^\circ$ $\gamma 12^\circ$

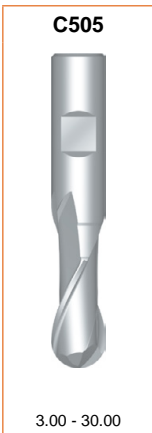
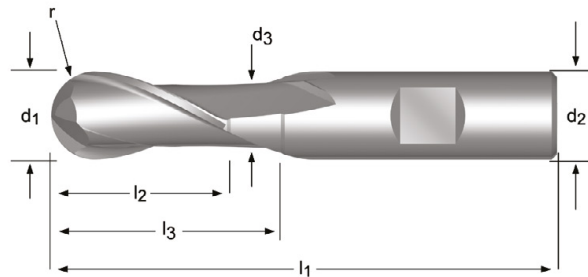

d_1 Ø mm	r ±0.05 mm	d_2 Ø _{h6} mm	l_2 mm	l_1 mm	z	l_3 mm	d_3 Ø mm	C505
3.00	1.50	6	8	52	2	-	-	C5053.0
4.00	2.00	6	11	55	2	-	-	C5054.0
5.00	2.50	6	13	57	2	-	-	C5055.0
6.00	3.00	6	13	57	2	-	-	C5056.0
8.00	4.00	10	19	69	2	-	-	C5058.0
10.00	5.00	10	22	72	2	-	-	C50510.0
12.00	6.00	12	26	83	2	-	-	C50512.0
14.00	7.00	12	26	83	2	37.5	11.5	C50514.0
16.00	8.00	16	32	92	2	43.5	15.5	C50516.0
20.00	10.00	20	38	104	2	53.5	19.5	C50520.0
22.00	11.00	20	38	104	2	53.5	19.5	C50522.0
25.00	12.50	25	45	121	2	64.5	24.5	C50525.0
28.00	14.00	25	45	121	2	64.5	24.5	C50528.0
30.00	15.00	25	45	121	2	64.5	24.5	C50530.0

C800

- Frese per scanalature a T
- T-Nutenfräser
- T-gleuffrees
- Fraises pour rainures en T

C800	1.1	1.2	1.3	1.4	1.5	1.6	2.1	2.2	2.3	3.1	3.2	3.3	3.4	4.1	4.2	4.3	5.1	5.2	5.3	6.1
	6.2	6.3	6.4	7.1	7.2	7.3	7.4	8.1	10.1											

C800 HSS-E  N  Z 6-8  $\lambda 15^\circ$ $\gamma 10^\circ$  DIN 1835  d11  DIN 851

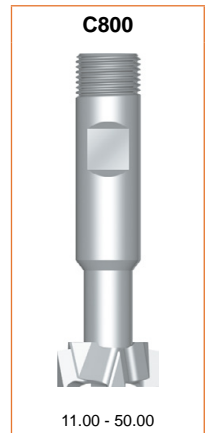
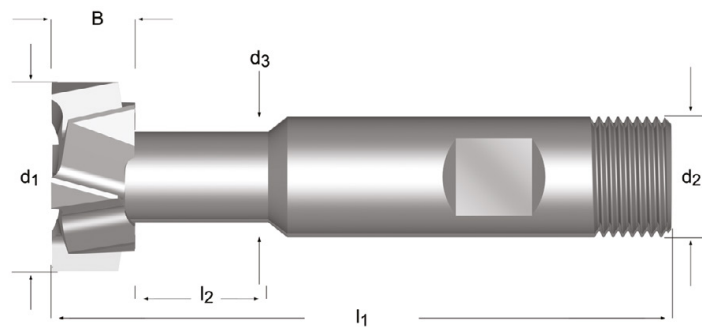

B	d ₁ ∅ mm	T DIN650	d ₃ ∅ mm	l ₂ mm	l ₁ mm	d ₂ ∅h ₆ mm	z	C800
4.0	11.00	5	4	6.5	53.5	10	6	C80011.0X5.0
6.0	12.50	6	5	9	57.0	10	6	C80012.5X6.0
8.0	16.00	8	7	12	62.0	10	6	C80016.0X8.0
8.0	18.00	10	8	15	70.0	12	6	C80018.0X10.0
9.0	21.00	12	10	18	74.0	12	8	C80021.0X12.0
11.0	25.00	14	12	20	82.0	16	8	C80025.0X14.0
14.0	32.00	18	15	26	90.0	16	8	C80032.0X18.0
18.0	40.00	22	19	27	108.0	25	8	C80040.0X22.0
22.0	50.00	28	25	34	124.0	32	8	C80050.0X28.0

C810

- Frese per scanalature a T
- T-Nutenfräser
- Duivenstaartfrees
- Fraises pour rainures en T

C810	▪	1.1	1.2	1.3	1.4	2.1	3.1	3.2	3.3	3.4	4.1	5.1	6.1	6.2	6.3	6.4	7.1	7.2	7.3	
	•	1.5	1.6	2.2	2.3	4.2	4.3	5.2	5.3	7.4	8.1	10.1								

C810 HSS N Z 6-8 $\lambda 12^\circ$ $\gamma 10^\circ$

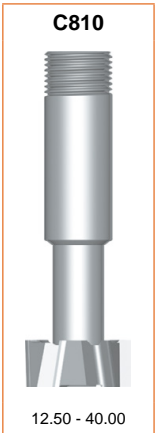
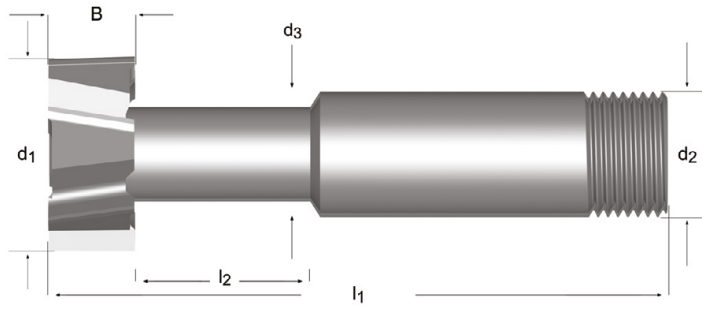

B	d ₁ Ø	T DIN650	d ₃ Ø	l ₂	l ₁	d ₂ Ø, -0.025	z	C810
mm	mm		mm	mm	mm	mm		
6.00	12.50	6.0	5.00	11	57.0	10.0	6	C8106.0
8.00	16.00	8.0	7.00	13	61.0	10.0	6	C8108.0
8.00	18.00	10.0	8.00	17	65.0	12.0	6	C81010.0
9.00	21.00	12.0	10.00	20	69.0	12.0	6	C81012.0
11.00	25.00	14.0	12.00	23	79.0	16.0	6	C81014.0
12.00	28.00	16.0	13.00	23	76.0	16.0	6	C81016.0
14.00	32.00	18.0	15.00	27	98.0	25.0	8	C81018.0
16.00	36.00	20.0	17.00	30	100.0	25.0	8	C81020.0
18.00	40.00	22.0	19.00	33	108.0	25.0	8	C81022.0

⁹⁾ Standard - BS 122/4 / Standard - BS 122/4 / Standaard - BS 122/4 / Standard - BS 122/4

- C825**
- Frese per scanalature a T
 - T-Nutenfräser
 - Duivenstaartfrees
 - Fraises pour rainures en T

C825	1.1	1.2	1.3	1.4	1.5	1.6	2.1	2.2	2.3	3.1	3.2	3.3	3.4	4.1	4.2	4.3	5.1	5.2	5.3	6.1	
	6.2	6.3	6.4	7.1	7.2	7.3	7.4	8.1	10.1												

C825 HSS-E  N  Z 8-12  $\lambda 15^\circ$ $\gamma 15^\circ$  js16  

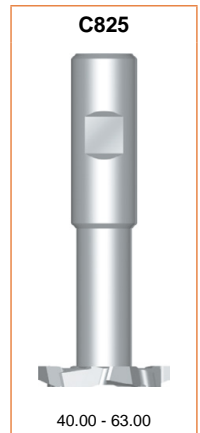
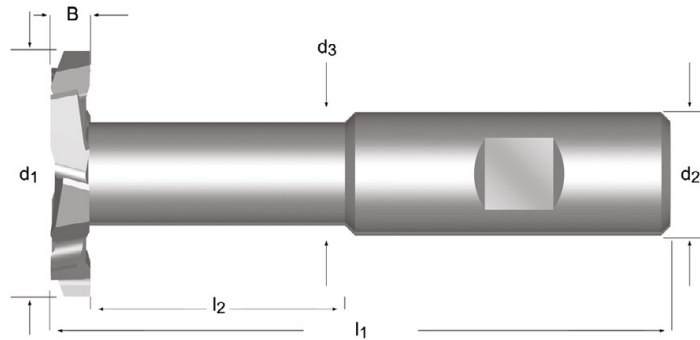

B	d ₁ ∅ mm	Ch	d ₃ ∅ mm	l ₂	l ₁	d ₂ ∅ _{h₆} mm	z	C825
3	40	0.15	19.2	46	100	20	8	C8253.0X40.0
4	40	0.15	19.2	45	100	20	8	C8254.0X40.0
5	40	0.15	19.2	44	100	20	8	C8255.0X40.0
6	40	0.15	19.2	43	100	20	8	C8256.0X40.0
8	40	0.15	19.2	41	100	20	8	C8258.0X40.0
10	40	0.15	19.2	39	100	20	8	C82510.0X40.0
6	63	0.15	24.2	67	130	25	12	C8256.0X63.0
8	63	0.15	24.2	65	130	25	12	C8258.0X63.0
10	63	0.15	24.2	63	130	25	12	C82510.0X63.0
12	63	0.15	24.2	61	130	25	12	C82512.0X63.0
14	63	0.15	24.2	59	130	25	12	C82514.0X63.0
16	63	0.15	24.2	57	130	25	12	C82516.0X63.0

C801

- Frese per scanalature a T
- T-Nutenfräser
- Duivenstaartfrees
- Fraises pour rainures en T

C801	1.1	1.2	1.3	1.4	1.5	1.6	2.1	2.2	2.3	3.1	3.2	3.3	3.4	4.1	4.2	4.3	5.1	5.2	5.3	6.1	
	6.2	6.3	6.4	7.1	7.2	7.3	7.4	8.1	10.1												

C801 HSS-E

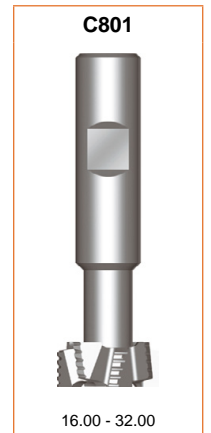
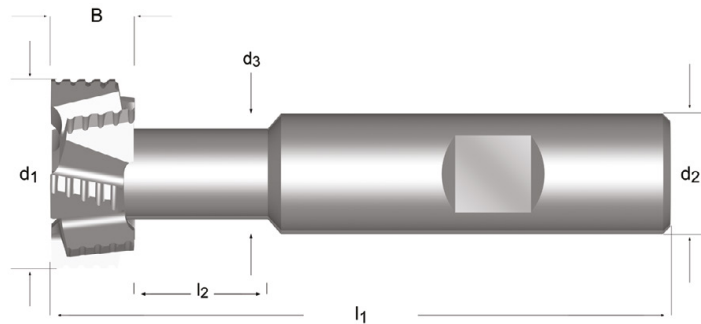

B	d ₁ Ø	T DIN650	d ₃ Ø	l ₂	l ₁	d ₂ Øh ₆	z	C801
8.0	16.0	8	7	10	62	10	6	C80116.0X8.0
8.0	18.0	10	8	13	70	12	6	C80118.0X10.0
9.0	21.0	12	10	16	74	12	6	C80121.0X12.0
11.0	25.0	14	12	17	82	16	8	C80125.0X14.0
14.0	32.0	18	15	22	90	16	8	C80132.0X18.0

C822

- Fresa per chiavetta Woodruff
- Schlitzfräser für Scheibenfeder
- Schijfspiefrees
- Fraises Woodruff

C822	1.1	1.2	1.3	1.4	1.5	1.6	2.1	2.2	2.3	3.1	3.2	3.3	3.4	4.1	4.2	4.3	5.1	5.2	5.3	6.1	
	6.2	6.3	6.4	7.1	7.2	7.3	7.4	8.1	10.1												

C822 HSS-E  N  Z 6-12  $\lambda 10^\circ$ $\gamma 10^\circ$  DIN 1835  h11  DIN 850

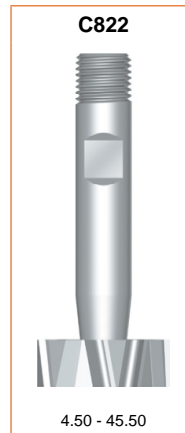
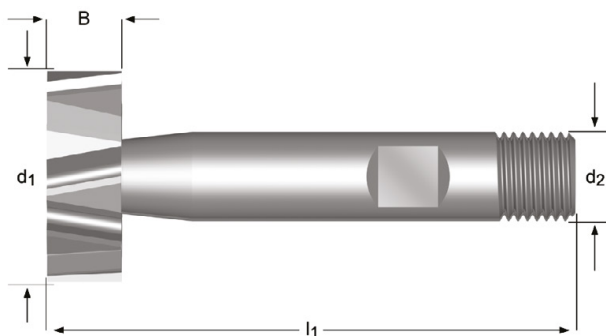

B	d ₁ Ø	l ₁	d ₂ Ø _{h₆}	z	C822
mm	mm	mm	mm		
1.0	4.50	50	6	6	C8224.5X1.0
1.5	7.50	50	6	6	C8227.5X1.5
2.0	7.50	50	6	6	C8227.5X2.0
2.0	10.50	50	6	8	C82210.5X2.0
2.5	10.50	50	6	8	C82210.5X2.5
3.0	10.50	50	6	8	C82210.5X3.0
3.0	13.50	56	10	8	C82213.5X3.0
4.0	13.50	56	10	8	C82213.5X4.0
3.0	16.50	56	10	8	C82216.5X3.0
4.0	16.50	56	10	8	C82216.5X4.0
5.0	16.50	56	10	8	C82216.5X5.0
3.0	19.50	63	10	10	C82219.5X3.0
4.0	19.50	63	10	10	C82219.5X4.0
5.0	19.50	63	10	10	C82219.5X5.0
5.0	22.50	63	10	10	C82222.5X5.0
6.0	22.50	63	10	10	C82222.5X6.0
8.0	22.50	63	10	10	C82222.5X8.0
6.0	25.50	63	10	12	C82225.5X6.0
6.0	28.50	63	10	12	C82228.5X6.0
8.0	28.50	63	10	12	C82228.5X8.0
10.0	28.50	71	12	12	C82228.5X10.0
8.0	32.50	71	12	12	C82232.5X8.0
10.0	32.50	71	12	12	C82232.5X10.0
10.0	45.50	71	12	12	C82245.5X10.0

C820

- Fresa per chiavetta Woodruff
- Schlitzfräser für Scheibenfeder
- Schijfspiefrees
- Fraises Woodruff

C820	▪	1.1	1.2	1.3	1.4	2.1	2.2	3.1	3.2	3.3	3.4	4.1	5.1	6.1	6.2	6.3	7.1	7.2	7.3	
	•	1.5	1.6	2.3	4.2	4.3	5.2	5.3	6.4	7.4	8.1	10.1								

C820 HSS N Z 6-12 $\lambda 12^\circ$ $\gamma 10^\circ$

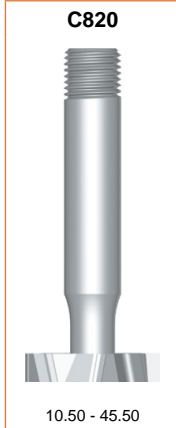
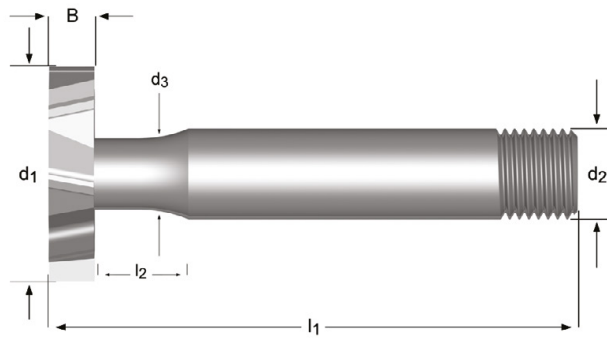

Nr.	B Inch	B mm	d ₁ Ø Inch	d ₁ Ø mm	d ₃ Ø mm	l ₂ mm	l ₁ mm	d ₂ Ø _{0,-0.025} Inch	d ₂ Ø _{0,-0.025} mm	z	C820
		2.00		10.50	3.90	10	57.0		12.0	6	C82010.5X2.0
		2.50		10.50	3.90	10	57.0		12.0	6	C82010.5X2.5
		3.00		10.50	4.20	10	57.0		12.0	6	C82010.5X3.0
204	1/16	1.59	1/2	12.70	3.30	10	57.0	1/2	12.7	6	C820204 ⁹⁾
404	1/8	3.18	1/2	12.70	4.85	10	57.0	1/2	12.7	6	C820404 ⁹⁾
		2.00		13.50	4.00	10	57.0		12.0	6	C82013.5X2.0
		2.50		13.50	4.00	10	57.0		12.0	6	C82013.5X2.5
		3.00		13.50	5.00	10	57.0		12.0	6	C82013.5X3.0
		4.00		13.50	5.00	10	57.0		12.0	6	C82013.5X4.0
405	1/8	3.18	5/8	15.88	5.65	10	57.0	1/2	12.7	6	C820405 ⁹⁾
505	5/32	3.97	5/8	15.88	6.35	10	57.0	1/2	12.7	6	C820505 ⁹⁾
		2.50		16.50	4.00	10	57.0		12.0	6	C82016.5X2.5
		3.00		16.50	5.00	10	57.0		12.0	6	C82016.5X3.0
		4.00		16.50	5.00	10	57.0		12.0	6	C82016.5X4.0
		5.00		16.50	5.60	10	57.0		12.0	6	C82016.5X5.0
406	1/8	3.18	3/4	19.05	5.50	10	57.0	1/2	12.7	6	C820406 ⁹⁾
506	5/32	3.97	3/4	19.05	6.35	10	57.0	1/2	12.7	6	C820506 ⁹⁾
606	3/16	4.76	3/4	19.05	7.15	10	57.0	1/2	12.7	6	C820606 ⁹⁾
		3.00		19.50	5.60	10	57.0		12.0	6	C82019.5X3.0
		4.00		19.50	5.60	10	57.0		12.0	6	C82019.5X4.0
		5.00		19.50	6.00	10	57.0		12.0	6	C82019.5X5.0
507	5/32	3.97	7/8	22.23	6.35	10	63.5	1/2	12.7	8	C820507 ⁹⁾
607	3/16	4.76	7/8	22.23	7.15	10	63.5	1/2	12.7	8	C820607 ⁹⁾
807	1/4	6.35	7/8	22.23	8.75	10	63.5	1/2	12.0	8	C820807 ⁹⁾
		4.00		22.50	5.60	10	63.5		12.0	8	C82022.5X4.0
		5.00		22.50	6.00	10	63.5		12.0	8	C82022.5X5.0
		6.00		22.50	6.50	10	63.5		12.0	8	C82022.5X6.0
608	3/16	4.76	1"	25.40	7.15	10	70.0	1/2	12.7	8	C820608 ⁹⁾
808	1/4	6.35	1"	25.40	8.75	10	70.0	1/2	12.7	8	C820808 ⁹⁾
		5.00		25.50	7.50	10	70.0		12.0	8	C82025.5X5.0
		6.00		25.50	7.50	10	70.0		12.0	8	C82025.5X6.0
		8.00		25.50	8.00	10	70.0		12.0	8	C82025.5X8.0
		5.00		28.50	8.00	12	70.0		12.0	8	C82028.5X5.0
		6.00		28.50	8.50	12	70.0		12.0	8	C82028.5X6.0
		8.00		28.50	9.00	12	70.0		12.0	8	C82028.5X8.0
610	3/16	4.76	1.1/4	31.75	7.95	12	70.0	1/2	12.7	10	C820610 ⁹⁾
810	1/4	6.35	1.1/4	31.75	9.50	12	70.0	1/2	12.7	10	C820810 ⁹⁾

⁹⁾ Standard - BS 122/4 / Standard - BS 122/4 / Standaard - BS 122/4 / Standard - BS 122/4

Nr.	B Inch	B mm	d ₁ Ø Inch	d ₁ Ø mm	d ₃ Ø mm	l ₂ mm	l ₁ mm	d ₂ Ø0,-0.025 Inch	d ₂ Ø0,-0.025 mm	z	C820
1210	3/8	9.53	1.1/4	31.75	11.95	12	70.0	1/2	12.7	10	C8201210 ⁹⁾
		5.00		32.50	8.00	12	70.0		12.0	10	C82032.5X5.0 ⁹⁾
		6.00		32.50	8.50	12	70.0		12.0	10	C82032.5X6.0
		8.00		32.50	9.00	12	70.0		12.0	10	C82032.5X8.0
811	1/4	6.35	1.3/8	34.93	11.10	20	76.0	1/2	12.7	10	C820811 ⁹⁾
1211	3/8	9.53	1.3/8	34.93	11.95	20	76.0	1/2	12.7	10	C8201211 ⁹⁾
		6.00		35.50	9.50	20	76.0		12.0	10	C82035.5X6.0
		8.00		35.50	11.50	20	76.0		12.0	10	C82035.5X8.0
812	1/4	6.35	1.1/2	38.10	11.10	20	76.0	1/2	12.7	10	C820812 ⁹⁾
1212	3/8	9.53	1.1/2	38.10	11.95	20	76.0	1/2	12.7	10	C8201212 ⁹⁾
		8.00		38.50	11.50	20	76.0		12.0	10	C82038.5X8.0
		10.00		38.50	11.50	20	76.0		12.0	10	C82038.5X10.0
		10.00		45.50	11.50	20	76.0		12.0	12	C82045.5X10.0

C837

- Frese a coda di rondine
- Winkel-Schaftfräser
- Zwaluwstaartfrees
- Fraises coniques

C837	▪	1.1	1.2	1.3	1.4	2.1	3.1	3.2	3.3	3.4	4.1	5.1	6.1	6.2	6.3	7.1	7.2	7.3	
	•	1.5	1.6	2.2	2.3	4.2	4.3	5.2	5.3	6.4	7.4	8.1							

C837 HSS

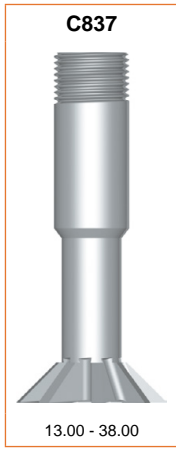
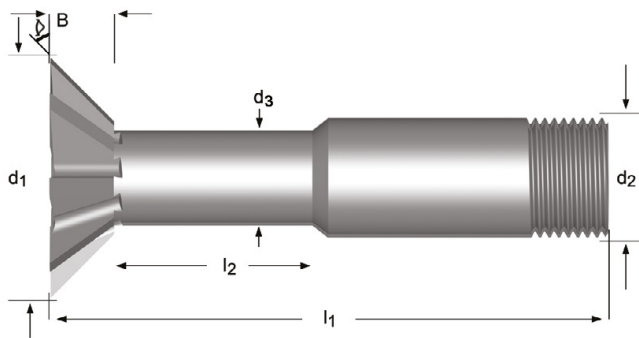

	B	d ₁ Ø	d ₁ Ø	d ₃ Ø	l ₂	l ₁	d ₂ Ø, -0.025	d ₂ Ø, -0.025	z	C837
	mm	Inch	mm	mm	mm	mm	Inch	mm		
45°	3.0		13.00	4.75	16.5	63.5		12.00	6	C83713.0
45°	4.0	5/8	15.88	6.35	17.5	66.5	1/2	12.70	6	C8375/8 ⁹⁾
45°	4.0		16.00	6.35	17.5	66.5		12.00	6	C83716.0
45°	5.5		19.00	6.35	16.0	66.5		12.00	6	C83719.0
45°	5.5	3/4	19.05	6.35	16.0	66.5	1/2	12.70	6	C8373/4 ⁹⁾
45°	6.5		22.00	7.15	16.0	68.5		12.00	6	C83722.0
45°	6.5	7/8	22.23	7.15	16.0	68.5	1/2	12.70	6	C8377/8 ⁹⁾
45°	7.5		25.00	7.95	16.5	70.0		12.00	6	C83725.0
45°	8.0	1"	25.40	7.95	16.0	70.0	1/2	12.70	6	C8371
45°	8.5		28.00	9.55	17.0	71.5		16.00	6	C83728.0
45°	10.5		38.00	12.70	16.0	78.5		25.00	8	C83738.0

⁹⁾ Standard - BS 122/4 / Standard - BS 122/4 / Standaard - BS 122/4 / Standard - BS 122/4

C835

- Frese a coda di rondine
- Winkel-Schaftfräser
- Zwaluwstaartfrees
- Fraises coniques

C835	▪	1.1	1.2	1.3	1.4	2.1	3.1	3.2	3.3	3.4	4.1	5.1	6.1	6.2	6.3	7.1	7.2	7.3	
	•	1.5	1.6	2.2	2.3	4.2	4.3	5.2	5.3	6.4	7.4	8.1							

C835 HSS N Z 6-8 $\lambda 0^\circ$ $\gamma 0^\circ$ DIN 1835D

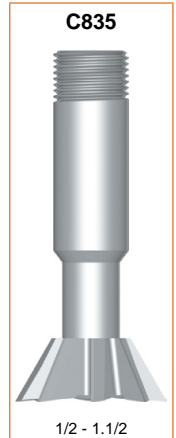
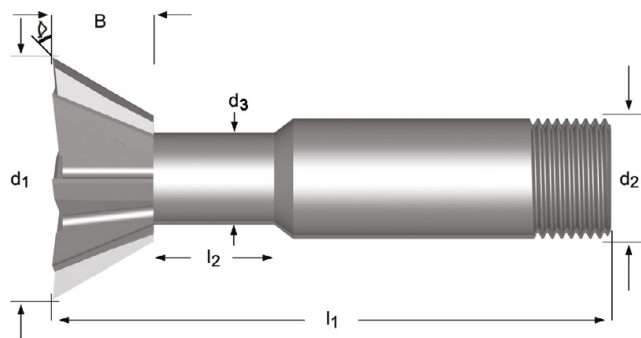

\triangle	B	d ₁ Ø	d ₁ Ø	d ₃ Ø	l ₂	l ₁	d ₂ Ø, -0.025	d ₂ Ø, -0.025	z	C835
	mm	Inch	mm	mm	mm	mm	Inch	mm		
60°	4.0	1/2	12.70	7.15	16.5	63.5	1/2	12.70	6	C8351/2 ⁹⁾
60°	4.0		13.00	7.15	16.5	63.5		12.00	6	C83513.0
60°	5.5	5/8	15.88	7.55	18.0	66.5	1/2	12.70	6	C8355/8 ⁹⁾
60°	5.5		16.00	7.55	18.0	66.5		12.00	6	C83516.0
60°	7.0		19.00	8.35	17.5	67.5		12.00	6	C83519.0
60°	7.0	3/4	19.05	8.35	17.5	67.5	1/2	12.70	6	C8353/4 ⁹⁾
60°	9.5		22.00	8.75	15.0	67.5		12.00	6	C83522.0
60°	9.5	7/8	22.23	8.75	15.0	67.5	1/2	12.70	6	C8357/8 ⁹⁾
60°	12.0		25.00	8.75	15.0	70.0		12.00	6	C83525.0
60°	12.0	1"	25.40	8.75	15.0	70.0	1/2	12.70	6	C8351 ⁹⁾
60°	12.5		28.00	11.10	15.5	73.0		16.00	6	C83528.0
60°	12.5	1.1/8	28.58	11.10	15.5	73.0	5/8	15.88	6	C8351.1/8 ⁹⁾
60°	13.5		32.00	12.70	16.0	74.5		16.00	8	C83532.0
60°	13.5	1.1/4	31.75	12.70	16.0	74.5	5/8	15.88	8	C8351.1/4 ⁹⁾
60°	14.5	1.3/8	34.93	12.70	16.0	82.5	1"	25.40	8	C8351.3/8 ⁹⁾
60°	14.5		35.00	12.70	16.0	82.5		25.00	8	C83535.0
60°	16.0		38.00	17.45	16.0	84.0		25.00	8	C83538.0
60°	16.0	1.1/2	38.10	17.45	16.0	84.0	1"	25.40	8	C8351.1/2 ⁹⁾

C830

- Frese a coda di rondine
- Winkel-Schaftfräser
- Zwaluwstaartfrees
- Fraises coniques

C830	1.1	1.2	1.3	1.4	1.5	1.6	2.1	2.2	2.3	3.1	3.2	3.3	3.4	4.1	4.2	4.3	5.1	5.2	5.3	6.1	
	6.2	6.3	6.4	7.1	7.2	7.3	7.4	8.1	10.1												

C830 HSS-E N Z 10-12 $\lambda 0^\circ$ $\gamma 0^\circ$

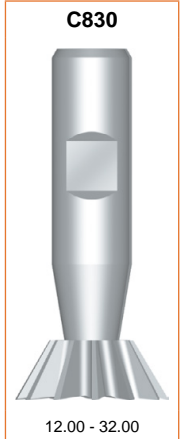
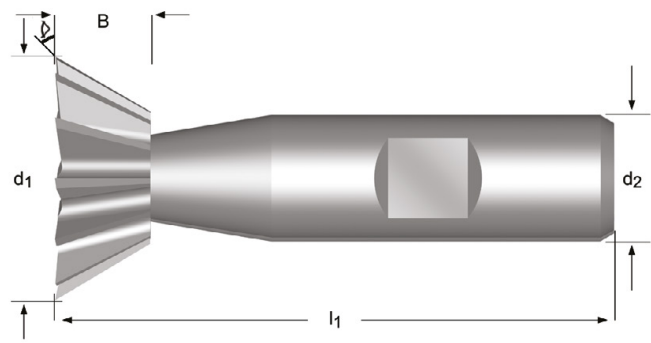

	B mm	d ₁ ∅ mm	l ₁ mm	d ₂ ∅ _{h₆} mm	z	C830
45°	3.5	12.0	54	10	10	C83012.0X45
45°	4.0	16.0	60	12	10	C83016.0X45
45°	5.0	20.0	63	12	10	C83020.0X45
45°	6.3	25.0	67	12	10	C83025.0X45
45°	8.0	32.0	71	16	12	C83032.0X45
60°	5.0	12.0	54	10	10	C83012.0X60
60°	6.3	16.0	60	12	10	C83016.0X60
60°	8.0	20.0	63	12	10	C83020.0X60
60°	10.0	25.0	67	12	10	C83025.0X60
60°	12.5	32.0	71	16	12	C83032.0X60

C831

- Frese a coda di rondine inversa
- Winkelstirnfräser
- Duivenstaartfrees
- Fraises coniques cône direct

C831	1.1	1.2	1.3	1.4	1.5	1.6	2.1	2.2	2.3	3.1	3.2	3.3	3.4	4.1	4.2	4.3	5.1	5.2	5.3	6.1	
	6.2	6.3	6.4	7.1	7.2	7.3	7.4	8.1	10.1												

C831 HSS-E  N  Z 10-12  $\lambda 0^\circ$ $\gamma 0^\circ$  DIN 1835B  js16  DIN 1833D

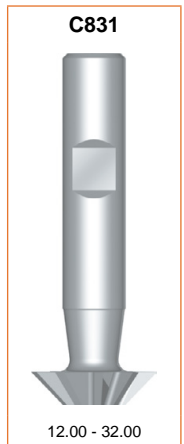
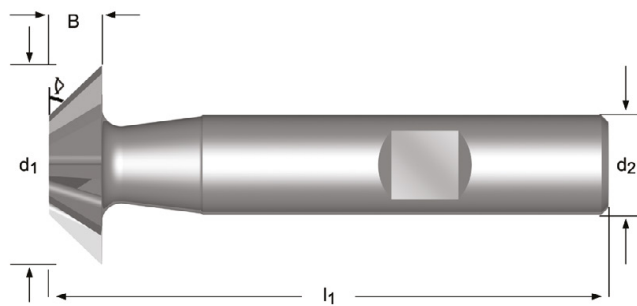

	B	d_1	l_1	d_2	z	C831
	mm	\varnothing mm	mm	\varnothing_{h_6} mm		
45°	3.5	12.0	54	10	10	C83112.0X45
45°	4.0	16.0	60	12	10	C83116.0X45
45°	5.0	20.0	63	12	10	C83120.0X45
45°	6.3	25.0	67	12	10	C83125.0X45
45°	8.0	32.0	71	16	12	C83132.0X45
60°	5.0	12.0	54	10	10	C83112.0X60
60°	6.3	16.0	60	12	10	C83116.0X60
60°	8.0	20.0	63	12	10	C83120.0X60
60°	10.0	25.0	67	12	10	C83125.0X60
60°	12.5	32.0	71	16	12	C83132.0X60

C710

- Frese raggate
- Viertelrund-Profilfräser
- Kwartholfrees
- Fraises concaves

C710	▪	1.1	1.2	1.3	1.4	2.1	2.2	3.1	3.2	3.3	3.4	4.1	4.2	5.1	5.2	6.1	6.2	6.3	7.1	7.2	7.3	
	•	1.5	1.6	2.3	4.3	5.3	6.4	7.4	10.1													

C710	HSS		N	Z 4		$\lambda 0^\circ$ $\gamma 0^\circ$						BS 122/4
------	-----	--	---	--------	--	---------------------------------------	--	--	--	--	--	-------------

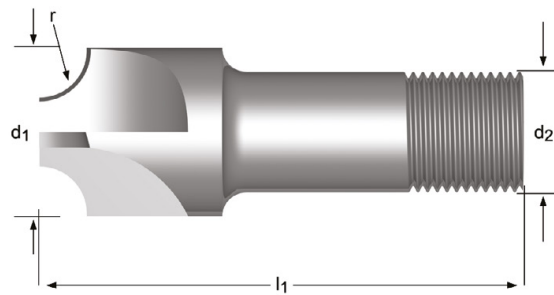

r Inch	d ₁ Ø Inch	d ₂ Øh ₈ Inch	d ₂ Ø mm	l ₁ mm	z	C710
1/16	3/8	3/8	9.53	60.5	4	C7101/16
1/8	1/2	1/2	12.70	60.5	4	C7101/8
5/32	9/16	1/2	12.70	60.5	4	C7105/32
3/16	5/8	5/8	15.88	60.5	4	C7103/16
1/4	7/8	5/8	15.88	63.5	4	C7101/4
3/8	1.1/16	1"	25.40	76.0	4	C7103/8
1/2	1.3/8	1"	25.40	82.5	4	C7101/2

C700

- Frese raggate
- Viertelrund-Profilfräser
- Kwartholfrees
- Fraises concaves

C700	1.1	1.2	1.3	1.4	1.5	1.6	2.1	2.2	2.3	3.1	3.2	3.3	3.4	4.1	4.2	4.3	5.1	5.2	5.3	6.1	
	6.2	6.3	6.4	7.1	7.2	7.3	7.4	10.1													

C700 HSS-E   N  Z 4-6  DIN 1835B 

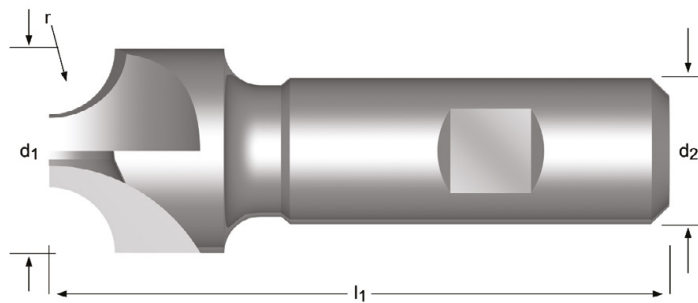

r mm	d ₁ Ø mm	d ₂ Ø _{h₈} mm	l ₁ mm	z	C700
1.00	10	10	60	4	C7001.0
1.50	10	10	60	4	C7001.5
2.00	10	10	60	4	C7002.0
2.50	10	10	60	4	C7002.5
3.00	12	12	60	4	C7003.0
3.50	12	12	60	4	C7003.5
4.00	15	12	60	4	C7004.0
5.00	18	16	70	4	C7005.0
6.00	21	16	70	4	C7006.0
7.00	24	16	70	4	C7007.0
8.00	24	16	70	4	C7008.0
9.00	28	20	85	4	C7009.0
10.00	28	20	85	4	C70010.0
12.00	35	20	100	4	C70012.0
12.50	35	20	100	4	C70012.5
14.00	42	25	100	4	C70014.0
15.00	48	25	105	5	C70015.0
16.00	48	25	105	5	C70016.0
20.00	60	32	115	6	C70020.0

- D200** • Fresa a tre tagli
 • Scheibenfräser, kreuzverzahnt
- D763** • Schijffrees
 • Fraise 3 tailles

D200; D763	1.1	1.2	1.3	1.4	1.5	1.6	2.1	2.2	2.3	3.1	3.2	3.3	3.4	4.1	4.2	4.3	5.1	5.2
	5.3	6.1	6.2	6.3	6.4	7.1	7.2	7.3	7.4	8.1								

D200	HSS-E			Z 16-30		$\lambda 15^\circ$ $\gamma 10^\circ$			js16		DIN 885A
D763	HSS-E			Z 28-44		$\lambda 15^\circ$ $\gamma 10^\circ$			js16		DIN 885A

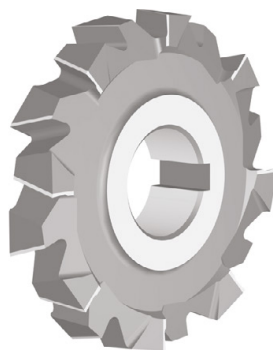
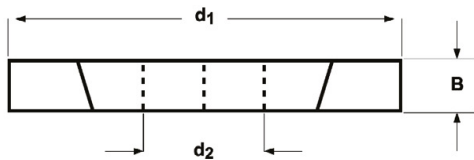

d ₁ ∅ mm	B mm	d ₂ ∅ mm	z	D200	D763
50.00	4.0	16	16	D20050.0X4.0	
50.00	5.0	16	16	D20050.0X5.0	
63.00	1.6	22	32		D76363.0X1.6
63.00	2.0	22	32		D76363.0X2.0
63.00	2.5	22	32		D76363.0X2.5
63.00	3.0	22	28		D76363.0X3.0
63.00	3.5	22	28		D76363.0X3.5
63.00	6.0	22	18	D20063.0X6.0	
63.00	8.0	22	18	D20063.0X8.0	
80.00	10.0	27	18	D20080.0X10.0	
80.00	2.0	27	36		D76380.0X2.0
80.00	2.5	27	36		D76380.0X2.5
80.00	3.0	27	32		D76380.0X3.0
80.00	3.5	27	32		D76380.0X3.5
80.00	6.0	27	20	D20080.0X6.0	
80.00	8.0	27	20	D20080.0X8.0	
100.00	10.0	32	22	D200100.0X10.0	
100.00	12.0	32	20	D200100.0X12.0	
100.00	14.0	32	20	D200100.0X14.0	
100.00	16.0	32	20	D200100.0X16.0	
100.00	2.0	32	44		D763100.0X2.0
100.00	3.0	32	40		D763100.0X3.0
100.00	8.0	32	22	D200100.0X8.0	
125.00	10.0	32	24	D200125.0X10.0	
125.00	12.0	32	22	D200125.0X12.0	
125.00	2.0	32	44		D763125.0X2.0
125.00	3.0	32	44		D763125.0X3.0

- D745**
- Seghe circolari
 - Metallkreissägeblatt
 - Zaagfrees met grove vertanding
 - Fraises scies

D745	▪	1.1	1.2	1.3	1.4	3.1	3.2	3.3	6.1	6.2	6.3	7.1	7.2	7.3	8.1	
	•	2.1	2.2													

D745 HSS   Z 28-100  $\gamma 15^\circ$  DIN 1838

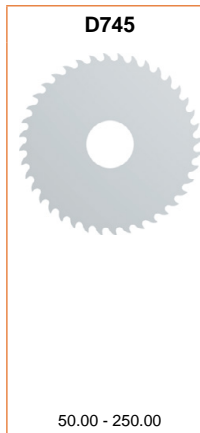
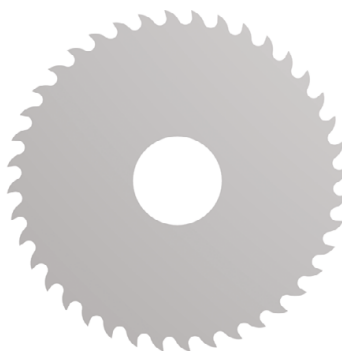
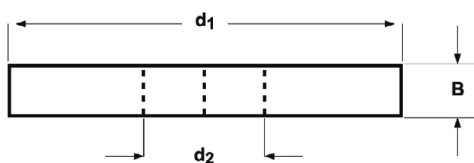

d_1 Ø mm	B mm	d_2 Ø mm	z	D745
50.00	0.5	13	48	D74550.0X.5
50.00	0.6	13	48	D74550.0X.6
50.00	0.8	13	40	D74550.0X.8
50.00	1.0	13	40	D74550.0X1.0
50.00	1.2	13	40	D74550.0X1.2
50.00	1.5	13	32	D74550.0X1.5
50.00	1.6	13	32	D74550.0X1.6
50.00	2.0	13	32	D74550.0X2.0
63.00	0.5	16	64	D74563.0X.5
63.00	0.6	16	48	D74563.0X.6
63.00	0.8	16	48	D74563.0X.8
63.00	1.0	16	48	D74563.0X1.0
63.00	1.2	16	40	D74563.0X1.2
63.00	1.5	16	40	D74563.0X1.5
63.00	1.6	16	40	D74563.0X1.6
63.00	2.0	16	40	D74563.0X2.0
80.00	1.0	22	48	D74580.0X1.0
80.00	1.2	22	48	D74580.0X1.2
80.00	1.5	22	48	D74580.0X1.5
80.00	1.6	22	48	D74580.0X1.6
80.00	2.0	22	40	D74580.0X2.0
80.00	2.5	22	40	D74580.0X2.5
80.00	3.0	22	40	D74580.0X3.0
100.00	1.0	22	64	D745100.0X1.0
100.00	1.2	22	64	D745100.0X1.2
100.00	1.5	22	48	D745100.0X1.5
100.00	1.6	22	48	D745100.0X1.6
100.00	2.0	22	48	D745100.0X2.0
100.00	2.5	22	48	D745100.0X2.5
100.00	3.0	22	40	D745100.0X3.0
100.00	4.0	22	40	D745100.0X4.0
125.00	1.0	22	80	D745125.0X1.0
125.00	1.2	22	64	D745125.0X1.2
125.00	1.5	22	64	D745125.0X1.5
125.00	1.6	22	64	D745125.0X1.6
125.00	2.0	22	64	D745125.0X2.0
125.00	2.5	22	48	D745125.0X2.5
125.00	3.0	22	48	D745125.0X3.0
125.00	4.0	22	48	D745125.0X4.0

d₁ ∅ mm	B mm	d₂ ∅ mm	z	D745
160.00	1.6	32	80	D745160.0X1.6
160.00	2.0	32	64	D745160.0X2.0
160.00	2.5	32	64	D745160.0X2.5
160.00	3.0	32	64	D745160.0X3.0
160.00	4.0	32	48	D745160.0X4.0
200.00	1.6	32	80	D745200.0X1.6
200.00	2.0	32	80	D745200.0X2.0
200.00	2.5	32	80	D745200.0X2.5
200.00	3.0	32	64	D745200.0X3.0
200.00	4.0	32	64	D745200.0X4.0
250.00	2.0	32	100	D745250.0X2.0
250.00	2.5	32	80	D745250.0X2.5
250.00	3.0	32	80	D745250.0X3.0

- D747**
- Seghe circolari
 - Metallkreissägeblatt fein
 - Zaagfrees met grove vertanding
 - Fraises scies

D747	▪	1.1	1.2	1.3	1.4	3.1	3.2	3.3	6.1	6.2	6.3	7.1	7.2	7.3	8.1	
	•	2.1	2.2													

D747 HSS   Z 40-200  $\gamma 5^\circ$  DIN 1837

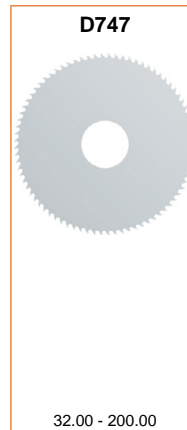
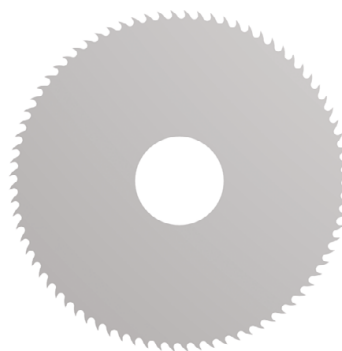
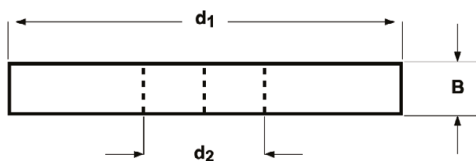

d_1 Ø mm	B mm	d_2 Ø mm	z	D747
32.00	0.3	8	80	D74732.0X.3
32.00	0.4	8	80	D74732.0X.4
32.00	0.5	8	80	D74732.0X.5
32.00	0.6	8	64	D74732.0X.6
32.00	0.8	8	64	D74732.0X.8
32.00	1.0	8	64	D74732.0X1.0
32.00	1.2	8	48	D74732.0X1.2
32.00	1.5	8	48	D74732.0X1.5
32.00	1.6	8	48	D74732.0X1.6
32.00	2.0	8	48	D74732.0X2.0
40.00	0.3	10	100	D74740.0X.3
40.00	0.4	10	100	D74740.0X.4
40.00	0.5	10	80	D74740.0X.5
40.00	0.6	10	80	D74740.0X.6
40.00	0.8	10	80	D74740.0X.8
40.00	1.0	10	64	D74740.0X1.0
40.00	1.2	10	64	D74740.0X1.2
40.00	1.5	10	64	D74740.0X1.5
40.00	1.6	10	64	D74740.0X1.6
40.00	2.0	10	48	D74740.0X2.0
50.00	0.3	13	128	D74750.0X.3
50.00	0.4	13	100	D74750.0X.4
50.00	0.5	13	100	D74750.0X.5
50.00	0.6	13	100	D74750.0X.6
50.00	0.8	13	80	D74750.0X.8
50.00	1.0	13	80	D74750.0X1.0
50.00	1.2	13	80	D74750.0X1.2
50.00	1.5	13	64	D74750.0X1.5
50.00	1.6	13	64	D74750.0X1.6
50.00	2.0	13	64	D74750.0X2.0
50.00	2.5	13	64	D74750.0X2.5
50.00	3.0	13	48	D74750.0X3.0
63.00	0.5	16	128	D74763.0X.5
63.00	0.6	16	100	D74763.0X.6
63.00	0.8	16	100	D74763.0X.8
63.00	1.0	16	100	D74763.0X1.0
63.00	1.2	16	80	D74763.0X1.2

d₁ ∅ mm	B mm	d₂ ∅ mm	z	D747
63.00	1.5	16	80	D74763.0X1.5
63.00	1.6	16	80	D74763.0X1.6
63.00	2.0	16	80	D74763.0X2.0
63.00	2.5	16	64	D74763.0X2.5
63.00	3.0	16	64	D74763.0X3.0
63.00	4.0	16	64	D74763.0X4.0
80.00	0.5	22	128	D74780.0X.5
80.00	0.6	22	128	D74780.0X.6
80.00	0.8	22	128	D74780.0X.8
80.00	1.0	22	100	D74780.0X1.0
80.00	1.2	22	100	D74780.0X1.2
80.00	1.5	22	100	D74780.0X1.5
80.00	1.6	22	100	D74780.0X1.6
80.00	2.0	22	80	D74780.0X2.0
80.00	2.5	22	80	D74780.0X2.5
80.00	3.0	22	80	D74780.0X3.0
80.00	4.0	22	64	D74780.0X4.0
100.00	0.5	22	160	D747100.0X.5
100.00	0.6	22	160	D747100.0X.6
100.00	0.8	22	128	D747100.0X.8
100.00	1.0	22	128	D747100.0X1.0
100.00	1.2	22	128	D747100.0X1.2
100.00	1.5	22	100	D747100.0X1.5
100.00	1.6	22	100	D747100.0X1.6
100.00	2.0	22	100	D747100.0X2.0
100.00	2.5	22	100	D747100.0X2.5
100.00	3.0	22	80	D747100.0X3.0
100.00	4.0	22	80	D747100.0X4.0
125.00	1.0	22	160	D747125.0X1.0
125.00	1.2	22	128	D747125.0X1.2
125.00	1.5	22	128	D747125.0X1.5
125.00	1.6	22	128	D747125.0X1.6
125.00	2.0	22	128	D747125.0X2.0
125.00	2.5	22	100	D747125.0X2.5
125.00	3.0	22	100	D747125.0X3.0
125.00	4.0	22	100	D747125.0X4.0
160.00	1.0	32	160	D747160.0X1.0
160.00	1.2	32	160	D747160.0X1.2
160.00	1.5	32	160	D747160.0X1.5
160.00	1.6	32	160	D747160.0X1.6
160.00	2.0	32	128	D747160.0X2.0
160.00	2.5	32	128	D747160.0X2.5
160.00	3.0	32	128	D747160.0X3.0
160.00	4.0	32	100	D747160.0X4.0
160.00	5.0	32	100	D747160.0X5.0
200.00	1.0	32	200	D747200.0X1.0
200.00	1.2	32	200	D747200.0X1.2
200.00	2.0	32	160	D747200.0X2.0
200.00	3.0	32	128	D747200.0X3.0

- D752** • Seghe circolari
• Metallkreissägeblatt
- D753** • Cirkelzaag met grove vertanding
• Fraises scies

D752; D753	▪	1.1	1.2	1.3	1.4	3.1	3.2	3.3	6.1	6.2	6.3	7.1	7.2	7.3	8.1	
	•	2.1	2.2													

D752	HSS			Z 80-180		$\gamma 18^\circ$			ST				
D753	HSS			Z 100-140		$\gamma 18^\circ$			ST				

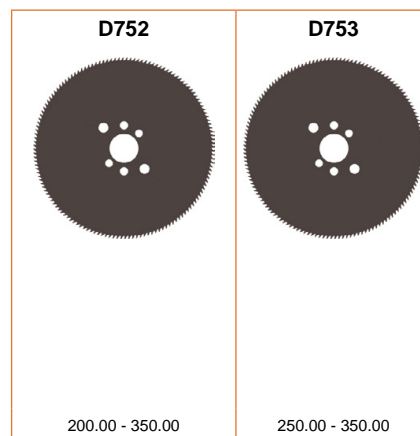
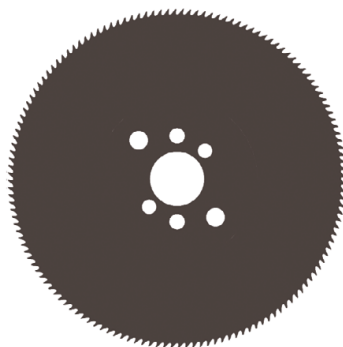
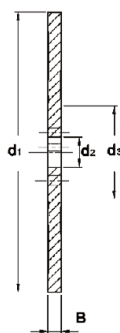
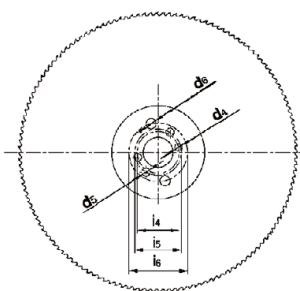

d ₁ Ø mm	B mm	d ₂ Ø mm	z	P mm	d ₃ Ø mm	d ₄ Ø mm	i ₄ mm	d ₅ Ø mm	i ₅ mm	d ₆ Ø mm	i ₆ mm	D752	D753
250	2.0	32	100	8	100	8	45	9	50	11	63		D753250.0X2.0
250	2.0	32	128	6	100	8	45	9	50	11	63	D752250.0X2.0X128	
275	2.5	32	110	8	100	8	45	9	50	11	63	D752275.0X2.5X110	
300	2.5	32	120	8	100	8	45	9	50	11	63	D752300.0X2.5X160	D753300.0X2.5
300	2.5	32	160	6	100	8	45	9	50	11	63		
315	2.5	32	120	8	100	8	45	9	50	11	63		D753315.0X2.5
315	2.5	32	160	6	100	8	45	9	50	11	63	D752315.0X2.5X160	
350	2.5	32	140	8	120	8	45	9	50	11	63		D753350.0X2.5
350	2.5	32	180	6	120	8	45	9	50	11	63	D752350.0X2.5X180	

- D750** • Seghe circolari
• Metallkreissägeblatt
- D751** • Cirkelzaag met grove vertanding
• Fraises scies

D750; D751	▪	1.1	1.2	1.3	1.4	3.1	3.2	3.3	6.1	6.2	6.3	7.1	7.2	7.3	8.1	
	•	2.1	2.2													

D750	HSS			Z 128-220		$\gamma 18^\circ$		ST			
D751	HSS			Z 160-350		$\gamma 18^\circ$		ST			

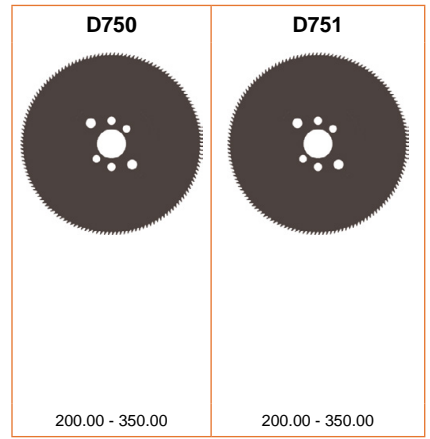
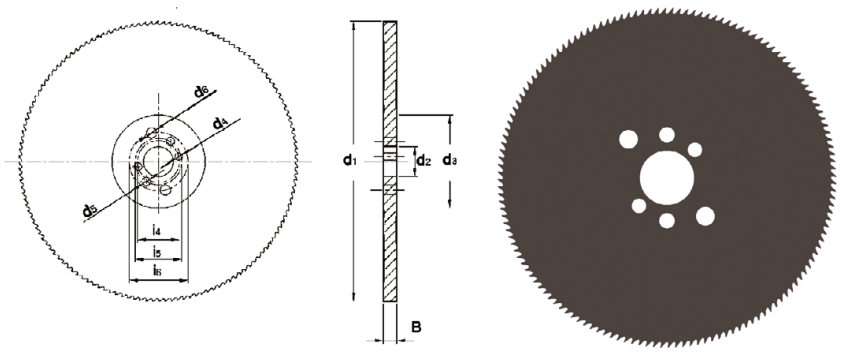

d ₁ Ø mm	B mm	d ₂ Ø mm	z	P mm	d ₃ Ø mm	d ₄ Ø mm	i ₄ mm	d ₅ Ø mm	i ₅ mm	d ₆ Ø mm	i ₆ mm	D750	D751
200	1.8	32	130	5	100	8	45	9	50	11	63	D750200.0X1.8	
200	1.8	32	160	4	100	8	45	9	50	11	63		D751200.0X1.8X160
200	1.8	32	200	3	100	8	45	9	50	11	63		D751200.0X1.8X200
225	2.0	32	140	5	100	8	45	9	50	11	63	D750225.0X2.0	
225	2.0	32	180	4	100	8	45	9	50	11	63		D751225.0X2.0X180
225	2.0	32	220	3	100	8	45	9	50	11	63		D751225.0X2.0X220
250	2.0	32	160	5	100	8	45	9	50	11	63	D750250.0X2.0	
250	2.0	32	200	4	100	8	45	9	50	11	63		D751250.0X2.0X200
250	2.0	32	250	3	100	8	45	9	50	11	63		D751250.0X2.0X250
275	2.5	32	180	5	100	8	45	9	50	11	63	D750275.0X2.5	
275	2.5	32	220	4	100	8	45	9	50	11	63		D751275.0X2.5X220
275	2.5	32	280	3	100	8	45	9	50	11	63		D751275.0X2.5X280
300	2.5	32	180	5	100	8	45	9	50	11	63	D750300.0X2.5	
300	2.5	32	220	4	100	8	45	9	50	11	63		D751300.0X2.5X220
300	2.5	32	300	3	100	8	45	9	50	11	63		D751300.0X2.5X300
315	2.5	32	200	5	100	8	45	9	50	11	63	D750315.0X2.5	
315	2.5	32	240	4	100	8	45	9	50	11	63		D751315.0X2.5X240
315	2.5	32	320	3	100	8	45	9	50	11	63		D751315.0X2.5X320
350	2.5	32	220	5	120	8	45	9	59	11	63	D750350.0X2.5	
350	2.5	32	280	4	120	8	45	9	50	11	63		D751350.0X2.5X280
350	2.5	32	350	3	120	8	45	9	50	11	63		D751350.0X2.5X350

D400 • Frese con foro (senza codolo)
• Walzenstirnfräser

D420 • Mantelkopffrees
• Fraises 2 tailles finition

D400	▪	1.1	1.2	1.3	1.4	2.1	2.3	3.1	3.2	3.3	3.4	4.1	5.1	6.1	6.2	6.3	7.2	7.3			
	•	1.5	1.6	2.2	4.2	4.3	5.2	5.3	6.4	7.1	7.4	8.1	8.2	8.3	10.1						
D420	▪	1.1	1.2	1.3	1.4	1.5	1.6	2.1	2.2	2.3	3.1	3.2	3.3	3.4	4.1	4.2	4.3	5.1	5.2	5.3	6.1
		6.2	6.3	6.4	7.2	7.3	7.4	8.1	10.1												
	•	7.1	8.2	8.3																	

D400	HSS-E		N	Z 8-12		$\lambda 30^\circ$ $\gamma 12^\circ$		js16		DIN 1880
D420	HSS-E		N	Z 8-12		$\lambda 30^\circ$ $\gamma 12^\circ$	TICN 	js16		DIN 1880

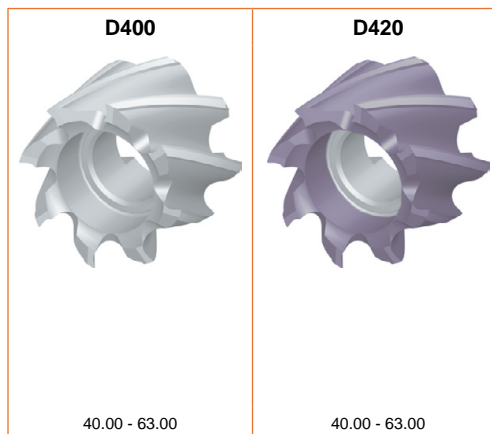
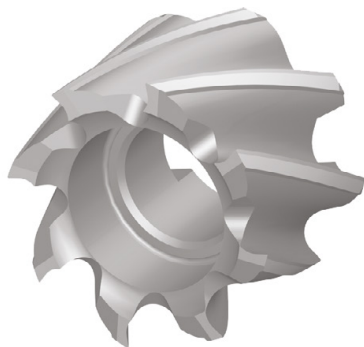
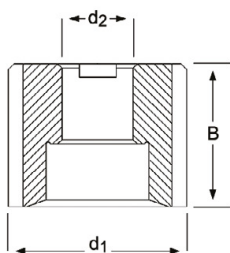

d_1 Ø mm	B mm	d_2 Ø mm	z	D400	D420
40.00	32	16	8	D40040.0	D42040.0
50.00	36	22	8	D40050.0	D42050.0
63.00	40	27	8	D40063.0	D42063.0

D402 • Frese con foro (senza codolo)
• Walzenstirnfräser

D422 • Mantelkop-ruwfrees
• Fraises 2 tailles finition

D402	▪	1.1	1.2	1.3	1.4	2.1	2.3	3.1	3.2	3.3	3.4	4.1	5.1	6.1	6.2	6.3	7.2	7.3			
	•	1.5	1.6	2.2	4.2	4.3	5.2	5.3	6.4	7.1	7.4	8.1	8.2	8.3	10.1						
D422	▪	1.1	1.2	1.3	1.4	1.5	1.6	2.1	2.2	2.3	3.1	3.2	3.3	3.4	4.1	4.2	4.3	5.1	5.2	5.3	6.1
		6.2	6.3	6.4	7.2	7.3	7.4	8.1	10.1												
	•	7.1	8.2	8.3																	

D402	HSS-E		NR	Z 6-10		$\lambda 30^\circ$ $\gamma 12^\circ$		js16		DIN 1880
D422	HSS-E		NR	Z 6-10		$\lambda 30^\circ$ $\gamma 12^\circ$	TICN	js16		DIN 1880

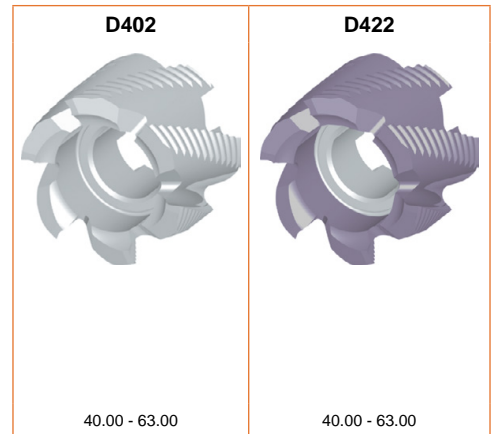
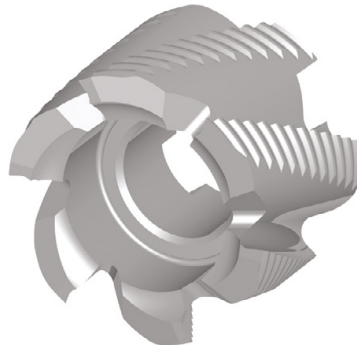
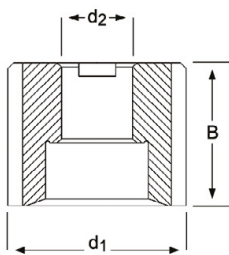

d_1 Ø mm	B mm	d_2 Ø mm	z	D402	D422
40.00	32	16	6	D40240.0	D42240.0
50.00	36	22	6	D40250.0	D42250.0
63.00	40	27	8	D40263.0	D42263.0

P601	502	P721	520	P817	517
P605	506	P801	501	P819	518
P607	508	P801C	501	P821	519
P609	510	P803	503	P821C	519
P611	512	P803C	503	P823	521
P613	514	P805	505	P825	522
P615	516	P805C	505	P831	502
P621	520	P807	507	P833	504
P701	502	P807C	507	P835	506
P703	504	P809	509	P837	508
P705	506	P811	511	P841	512
P707	508	P811C	511	P842	520
P709	510	P813	513	P843	523
P711	512	P813C	513	P844	524
P713	514	P815	515	P880	525
P715	516	P815C	515	P890	526

495 - 526

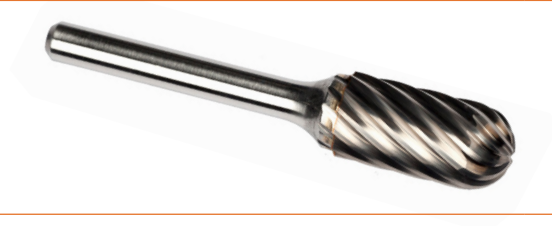

Materiale	Material	Materiaal	Matière
Applicazione	Anwendung	Toepassing	Utilisation
spallamento	Stirngeometrie	Kopvertanding	Coupe en bout
Trattamento superficiale	Oberfläche	Oppervlaktebehandeling	Revêtement
Angolo al vertice	Spitzenwinkel	Punthoek	Affûtage
Tipo	Typ	Type	Type
Normativa	Standard	Norm	Standard
<ul style="list-style-type: none"> ■ Raccomandato ● Accettabile <p>Esempio 10 = Velocità periferica in m/min +/- 10%</p>	<p>Sehr gut für die Anwendung Gut für die Anwendung</p> <p>Beispiel 10 = Schnittgeschwindigkeit (m/min) +/- 10 %</p>	<p>Uitstekend voor deze toepassing Acceptabel voor deze toepassing</p> <p>Voorbeeld 10= snijsnelheid in m/min +/-10%</p>	<p>Excellent pour les applications Acceptable pour les applications</p> <p>Exemple 10 = Vitesse périphérique en mètres/ minute +/- 10%</p>
Codice prodotto	Produktbezeichnung	Productcode	Codes
Gamma diametri	Durchmesserbereich	Diameterreeks	Gamme

AMG	Italiano	Deutsch	Nederlands	Français
1.1	Acciaio dolce magnetico	Magnetweicheisen	Automatenstaal, zachtstaal	Acier doux magnétique
1.2	Acciaio da costruzione e da cementazione	Baustahl, Einsatzstahl	Constructiestaal, inzetstaal	Acier de construction, Acier de cémentation
1.3	Acciaio al carbonio	Kohlenstoffstahl	Koolstofstaal	Acier au carbone ordinaire
1.4	Acciaio legato	Legierter Stahl	Gelegeerd staal	Acier allié
1.5	Acciaio legato / Acciaio bonificato e temprato	Legierter und vergüteter Stahl	Gelegeerd en veredeld staal	Acier allié/ Acier trempé et revenu
1.6	Acciaio legato / Acciaio bonificato e temprato	Legierter und vergüteter Stahl	Hooggelegeerd veredeld staal	Acier allié/ Acier trempé et revenu
1.7	Acciaio legato/temprato	Legierter gehärteter Stahl	Gelegeerd en gehard staal	Acier allié trempé
1.8	Acciaio legato/temprato	Legierter gehärteter Stahl	Gelegeerd en gehard staal	Acier allié trempé
2.1	Acciaio inossidabile/automatico	Rostfreier Stahl, geschwefelt	Roestvast automatenstaal	Acier inoxydable de décolletage
2.2	Austenitico	Austenitisch	Austenitisch	Austénitique
2.3	Ferritico+Austenitico, Martensitico	Ferritisch+Austenitisch, Martensitisch	Ferritisch+Austenitisch, Martensitisch	Ferritique + Austénitique, Martensitique
2.4	Acciai inossidabili con indurimento da precipitazione	Vergüteter rostfreier Stahl	Precipitatiehardend roestvast staal	Acier inoxydable Treppe
3.1	Ghisa con grafite lamellare	Grauguss	Gietijzer Lamellair	Graphite lamellaire
3.2	Ghisa con grafite lamellare	Vergüteter Grauguss	Gietijzer Lamellair	Graphite lamellaire
3.3	Ghisa malleabile con grafite sferoidale	Kugelgraphitguss, Temperguss	Nodulair gietijzer / Smeedbaar gietijzer	Graphite nodulaire/ Fonte malléable
3.4	Ghisa malleabile con grafite sferoidale	Kugelgraphitguss, Temperguss	Nodulair gietijzer / Smeedbaar gietijzer	Graphite nodulaire/ Fonte malléable
4.1	Titanio non legato	Reintitan	Titaan, ongelegeerd	Titane, non-allié
4.2	Leghe di titanio	Titan-Legierungen	Titaan, gelegeerd	Titane, allié
4.3	Leghe di titanio	Titan-Legierungen	Titaan, gelegeerd	Titane, allié
5.1	Nichel non legato	Reinnickel	Nikkel, ongelegeerd	Nickel, non-allié
5.2	Leghe di nichel	Nickel-Legierungen	Nikkel, gelegeerd	Nickel, allié
5.3	Leghe di nichel	Nickel-Legierungen	Nikkel, gelegeerd	Nickel, allié
6.1	6.1 Rame	Kupfer	Koper	Cuivre
6.2	β-Ottone, Bronzo	Kurzspanendes Messing, Bronze	β-Messing, brons	β-Laiton, Bronze
6.3	α-Ottone	Langspanendes Messing	α-Messing	α-Laiton
6.4	Bronzo ad alta resistenza	Cu-Al-Fe-Legierung, (Ampco)	Extra-sterk brons	Bronze, haute résistance
7.1	Al, Mg, non legato	Al, Mg, unlegiert	Al, Mg, ongelegeerd	Al, Mg, non-allié
7.2	Leghe di Al, Si < 0.5%	Al legiert, Si<0.5 %	Al gelegeerd, Si < 0.5%	Al allié, Si < 0.5%
7.3	Leghe di Al, Si > 0.5% < 10%	Al legiert, Si>0.5 %<10 %	Al gelegeerd, Si > 0.5% < 10%	Al allié, Si > 0.5% < 10%
7.4	Leghe di Al, Si > 10% Rinforzate Whisker Leghe di Al, Leghe di Mg	Al legiert, Si>10 % Whisker verstärkte Al-Legierung, Mg-Legierung	Al gelegeerd, Si>10% whisker versterkt Al-legierungen, Mg-legierungen	Al allié, Si>10% Alliages d'Al ou Mg, céramique renforcée
8.1	Materiali termoplastici	Thermoplaste	Thermoplasten	Thermoplastiques
8.2	Materiali plastici termoindurenti	Duroplaste	Duraplasten	Plastiques thermodurcissables
8.3	Materiali plastici rinforzati	Faserverstärkte Kunststoffe	Versterkte kunststofmaterialen	Plastiques renforcés
9.1	Cermets (materiali metallo-ceramic)	Cermets (Metallkeramik)	Cermets (metal-ceramics)	Cermets (céramiques métalliques)
10.1	Grafite standard	Graphit	Standaard Grafiet	Graphite standard

	HM	HM	HM	HM	HM	HM	HM	HM	HM	HM	HM	HM	HM	HM	HM		
	A	A	A	A	A	B	B	B	B	C	C	C	C	C	D	D	
		TiAIN					TiAIN									TiAIN	
	DC	DC	ST	VA	AL	DC	DC	ST	AL	DC	DC	ST	VA	AL	DC	DC	
	P801	P801C	P701	P601	P831	P803	P803C	P703	P833	P805	P805C	P705	P605	P835	P807	P807C	
	3.00 - 16.00	3.00 - 12.70	6.00 - 12.70	3.00 - 12.70	6.00 - 12.70	3.00 - 16.00	3.00 - 12.70	6.00 - 12.70	6.00 - 12.70	3.00 - 16.00	3.00 - 12.70	6.00 - 12.70	3.00 - 12.70	6.00 - 12.70	3.00 - 16.00	3.00 - 12.70	
AMG	501	501	502	502	502	503	503	504	504	505	505	506	506	506	507	507	ISO
1.1	■	■	■			■	■	■		■	■	■			■	■	P 1
1.2	■	■	■			■	■	■		■	■	■			■	■	P 1
1.3	■	■	■			■	■	■		■	■	■			■	■	P 2
1.4	■	■	■			■	■	■		■	■	■			■	■	P 3
1.5	■	■	■			■	■	■		■	■	■			■	■	P 4
1.6	■	■	■			■	■	■		■	■	■			■	■	H 1
1.7	■	■	■			■	■	■		■	■	■			■	■	H 3
1.8	■	■	■			■	■	■		■	■	■			■	■	H 4
2.1	■	■	■	■	●	■	■	■	●	■	■	■	■	■	■	■	M 1
2.2	■	■	■	■		■	■	■		■	■	■	■	■	■	■	M 3
2.3	■	■	■	■		■	■	■		■	■	■	■	■	■	■	M 2
2.4	■	■	■	■		■	■	■		■	■	■	■	■	■	■	S 2
3.1	■	■	■	■		■	■	■		■	■	■	■	■	■	■	K 1
3.2	■	■	■	■		■	■	■		■	■	■	■	■	■	■	K 2
3.3	■	■	■	■		■	■	■		■	■	■	■	■	■	■	K 3
3.4	■	■	■	■		■	■	■		■	■	■	■	■	■	■	K 4
4.1	■	■	■	■	●	■	■	■	●	■	■	■	■	■	■	■	S 1
4.2	■	■	■	■		■	■	■		■	■	■	■	■	■	■	S 2
4.3	■	■	■	■		■	■	■		■	■	■	■	■	■	■	S 3
5.1	■	■	■	■	●	■	■	■	●	■	■	■	■	■	■	■	S 1
5.2	■	■	■	■		■	■	■		■	■	■	■	■	■	■	S 2
5.3	■	■	■	■		■	■	■		■	■	■	■	■	■	■	S 3
6.1	●	●	■	■		■	■	■	●	■	■	■	■	■	■	■	N 3
6.2	■	■	■	■	●	■	■	■	●	■	■	■	■	■	■	■	N 4
6.3	■	■	■	■		■	■	■		■	■	■	■	■	■	■	N 3
6.4	■	■	■	■		■	■	■		■	■	■	■	■	■	■	N 4
7.1				■					■				■				N 1
7.2				■					■				■				N 1
7.3				■					■				■				N 1
7.4				■					■				■				N 2
8.1				■					■				■				O
8.2				■					■				■				O
8.3				■					■				■				O
9.1	■	■				■	■			■	■				■	■	H
10.1																	O

	HM	HM	HM	HM	HM	HM	HM	HM	HM	HM	HM	HM	HM	HM	HM	HM	
	D	D	D	E	E	E	F	F	F	F	F	G	G	G	G	H	
	ST	VA	AL	DC	ST	VA	DC	DC	ST	VA	AL	DC	DC	ST	VA	DC	
	P707	P607	P837	P809	P709	P609	P811	P811C	P711	P611	P841	P813	P813C	P713	P613	P815	
	6.00 - 12.70	3.00 - 12.70	6.00 - 12.70	3.00 - 16.00	12.70	8.00 - 12.70	3.00 - 16.00	3.00 - 12.70	6.00 - 12.70	3.00 - 12.70	6.00 - 12.70	3.00 - 16.00	3.00 - 12.70	6.00 - 12.70	6.00 - 12.70	3.00 - 16.00	
AMG	508	508	508	509	510	510	511	511	512	512	512	513	513	514	514	515	ISO
1.1	■			■	■		■	■	■			■	■	■		■	P 1
1.2	■			■	■		■	■	■			■	■	■		■	P 1
1.3	■			■	■		■	■	■			■	■	■		■	P 2
1.4	■			■	■		■	■	■			■	■	■		■	P 3
1.5	■			■	■		■	■	■			■	■	■		■	P 4
1.6	■			■	■		■	■	■			■	■	■		■	H 1
1.7				■	■		■	■	■			■	■	■		■	H 3
1.8				■	■		■	■	■			■	■	■		■	H 4
2.1		■	●	■		■	■	■		■	●	■	■		■	■	M 1
2.2		■		■		■	■	■		■		■	■		■	■	M 3
2.3		■		■		■	■	■		■		■	■		■	■	M 2
2.4		■		■		■	■	■		■		■	■		■	■	S 2
3.1				■		■	■	■		■		■	■		■	■	K 1
3.2				■		■	■	■		■		■	■		■	■	K 2
3.3				■		■	■	■		■		■	■		■	■	K 3
3.4				■		■	■	■		■		■	■		■	■	K 4
4.1			●	■		■	■	■		■	●	■	■		■	■	S 1
4.2				■		■	■	■		■		■	■		■	■	S 2
4.3				■		■	■	■		■		■	■		■	■	S 3
5.1			●	■		■	■	■		■	●	■	■		■	■	S 1
5.2				■		■	■	■		■		■	■		■	■	S 2
5.3				■		■	■	■		■		■	■		■	■	S 3
6.1				■		■	●	●		■		■	●	●	■	●	N 3
6.2			●	■		■	■	■		■	●	■	■		■	■	N 4
6.3				■		■	■	■		■		■	■		■	■	N 3
6.4				■		■	■	■		■		■	■		■	■	N 4
7.1		■										■					N 1
7.2		■										■					N 1
7.3		■										■					N 1
7.4		■										■					N 2
8.1		■										■					O
8.2		■										■					O
8.3		■										■					O
9.1				■			■	■				■	■			■	H
10.1																	O

	HM	HM	HM	HM	HM	HM	HM	HM	HM	HM	HM	HM	HM	HM		
	H	H	H	J	K	L	L	L	L	L	M	N				
	TiAIN						TiAIN									
				60°	90°								135°	180°		
	DC	ST	VA	DC	DC	DC	DC	ST	VA	AL	DC	DC	GRP	GRP		
	P815C	P715	P615	P817	P819	P821	P821C	P721	P621	P842	P823	P825	P843	P844		
	8.00 - 12.70	8.00 - 12.70	8.00 - 12.70	3.00 - 16.00	3.00 - 16.00	3.00 - 16.00	3.00 - 12.70	10.00 - 12.70	8.00 - 12.70	6.00 - 12.70	3.00 - 16.00	3.00 - 16.00	3.00 - 8.00	3.00 - 8.00		
AMG		515	516	516	517	518	519	519	520	520	520	521	522	523	524	ISO
1.1	■	■		■	■	■	■	■	■			■	■			P 1
1.2	■	■		■	■	■	■	■	■			■	■			P 1
1.3	■	■		■	■	■	■	■	■			■	■			P 2
1.4	■	■		■	■	■	■	■	■			■	■			P 3
1.5	■	■		■	■	■	■	■	■			■	■			P 4
1.6	■	■		■	■	■	■	■	■			■	■			H 1
1.7	■			■	■	■	■	■	■			■	■			H 3
1.8	■			■	■	■	■	■	■			■	■			H 4
2.1	■		■	■	■	■	■	■	■	■	■	■	■			M 1
2.2	■		■	■	■	■	■	■	■	■	■	■	■			M 3
2.3	■		■	■	■	■	■	■	■	■	■	■	■			M 2
2.4	■		■	■	■	■	■	■	■	■	■	■	■			S 2
3.1	■			■	■	■	■	■	■			■	■			K 1
3.2	■			■	■	■	■	■	■			■	■			K 2
3.3	■			■	■	■	■	■	■			■	■			K 3
3.4	■			■	■	■	■	■	■			■	■			K 4
4.1	■			■	■	■	■	■	■	■	■	■	■			S 1
4.2	■			■	■	■	■	■	■	■	■	■	■			S 2
4.3	■			■	■	■	■	■	■	■	■	■	■			S 3
5.1	■			■	■	■	■	■	■	■	■	■	■			S 1
5.2	■			■	■	■	■	■	■	■	■	■	■			S 2
5.3	■			■	■	■	■	■	■	■	■	■	■			S 3
6.1	■			■	■	■	■	■	■	■	■	■	■			N 3
6.2	■			■	■	■	■	■	■	■	■	■	■			N 4
6.3	■			■	■	■	■	■	■	■	■	■	■			N 3
6.4	■			■	■	■	■	■	■	■	■	■	■			N 4
7.1										■						N 1
7.2										■						N 1
7.3										■						N 1
7.4										■						N 2
8.1										■			■	■		O
8.2										■			■	■		O
8.3										■			■	■		O
9.1	■			■	■	■	■				■	■				H
10.1																O



P880
Set



P890
Set

AMG	525	526	ISO
1.1			P 1
1.2			P 1
1.3			P 2
1.4			P 3
1.5			P 4
1.6			H 1
1.7			H 3
1.8			H 4
2.1			M 1
2.2			M 3
2.3			M 2
2.4			S 2
3.1			K 1
3.2			K 2
3.3			K 3
3.4			K 4
4.1			S 1
4.2			S 2
4.3			S 3
5.1			S 1
5.2			S 2
5.3			S 3
6.1			N 3
6.2			N 4
6.3			N 3
6.4			N 4
7.1			N 1
7.2			N 1
7.3			N 1
7.4			N 2
8.1			O
8.2			O
8.3			O
9.1			H
10.1			O

AL

DC

RPM / min

AMG	ISO	d ₁ Ø mm							
		3	6	8	10	12	16	20	
1.1 - 1.5	P	64 000	32 000	24 000	20 000	16 000	12 000	10 000	min
		83 000	42 000	32 000	25 000	21 000	16 000	13 000	max
1.6 - 1.8	H	51 000	26 000	20 000	16 000	13 000	10 000	8 000	min
		71 000	36 000	27 000	22 000	18 000	14 000	11 000	max
2	M	45 000	23 000	17 000	14 000	12 000	9 000	7 000	min
		64 000	32 000	24 000	20 000	16 000	12 000	10 000	max
3	K	58 000	29 000	22 000	19 000	15 000	11 000	9 000	min
		77 000	39 000	29 000	23 000	20 000	15 000	12 000	max
4	S 1	45 000	23 000	17 000	14 000	12 000	9 000	7 000	min
		58 000	29 000	22 000	18 000	15 000	11 000	9 000	max
5	S 1	45 000	23 000	17 000	14 000	12 000	9 000	7 000	min
		58 000	29 000	22 000	18 000	15 000	11 000	9 000	max
6	N	64 000	32 000	24 000	20 000	16 000	12 000	10 000	min
		71 000	36 000	27 000	22 000	18 000	14 000	11 000	max
7	N	71 000	36 000	27 000	22 000	18 000	14 000	11 000	min
		96 000	48 000	36 000	29 000	24 000	18 000	15 000	max
8	O	77 000	39 000	29 000	23 000	20 000	15 000	12 000	min
		96 000	48 000	36 000	29 000	24 000	18 000	15 000	max

ST

AMG	ISO		d ₁ Ø mm			
			3	6	10	12
1	P	Max	100 000	65 000	55 000	35 000
		Low	60 000	45 000	30 000	20 000
		High	80 000	60 000	40 000	30 000

VA

AMG	ISO		d ₁ Ø mm			
			3	6	10	12
2	M	Max	100 000	65 000	55 000	35 000
		Low	60 000	30 000	20 000	15 000
		High	80 000	45 000	30 000	22 000

GRP

AMG	ISO		d ₁ Ø mm					
			2	3	4	6	10	12
8	O	Low	40 000	25 000	20 000	20 000	15 000	10 000
		High	45 000	30 000	25 000	25 000	20 000	22 000

P801

- Lime rotative - cilindrico senza spallamento
- Frässtift- Zylinder ohne Stirverzahnung
- Stiffrees - Cilindrisch zonder kopvertanding
- Lime rotative - Cylindrique sans coupe en bout

brasato su 6.00 mm
 Gelötet, wenn der Kopfdurchmesser größer 6 mm ist
 > Ø 6mm gesoldeerd
 Brasée au-dessus de 6,00 mm

P801C

P801; P801C	▪	1.1	1.2	1.3	1.4	1.5	1.6	1.7	1.8	2.1	2.2	2.3	2.4	3.1	3.2	3.3	3.4	4.1	4.2	
		4.3	5.1	5.2	5.3	6.2	6.3	6.4	9.1											
	•	6.1																		

P801	HM	A					DC	
P801C	HM	A				TAIN	DC	



d_1 Ø mm	d_2 Øh ₇ mm	l_2 mm	l_1 mm	P801	P801C
3.00	3	14	38	P8013.0X3.0 ¹⁾	P801C3.0X3.0 ¹⁾
6.30	3	12.7	45	P8016.3X3.0	
6.00	6	18	50	P8016.0X6.0 ¹⁾	P801C6.0X6.0 ¹⁾
8.00	6	19	64	P8018.0X6.0	P801C8.0X6.0
9.60	6	19	64	P8019.6X6.0	P801C9.6X6.0
12.70	6	25	70	P80112.7X6.0	P801C12.7X6.0
16.00	6	25	70	P80116.0X6.0	

¹⁾ d2 tolleranza h6 / d2 toleranz h6 / d2 tolerantie h6 / d2 tolérance h6

- P701** • Lime rotative - cilindrico senza spallamento
P601 • Frässtift- Zylinder ohne Stirnverzahnung
P831 • Stiffrees - Cilindrisch zonder kopverzanding
 • Lime rotative - Cylindrique sans coupe en bout

brasato su 6.00 mm
 Gelötet, wenn der Kopfdurchmesser größer 6 mm ist
 > Ø 6mm gesoldeerd
 Brasée au-dessus de 6,00 mm

P701	▪	1.1	1.2	1.3	1.4	1.5	1.6	
P601	▪	2.1	2.2	2.3	2.4			
P831	▪	7.1	7.2	7.3	7.4	8.1	8.2	8.3
	•	2.1	4.1	5.1	6.2			

P701	HM	A					ST	
P601	HM	A					VA	
P831	HM	A					AL	

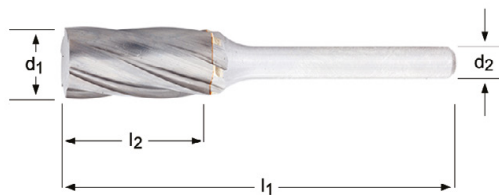

	P701	P601	P831
	6.00 - 12.70	3.00 - 12.70	6.00 - 12.70
d ₁ Ø mm	P701	P601	P831
3.00		P6013.0X3.0 ¹⁾	
6.30		P6016.3X3.0	
6.00	P7016.0X6.0 ¹⁾	P6016.0X6.0 ¹⁾	P8316.0X6.0 ¹⁾
8.00	P7018.0X6.0	P6018.0X6.0	
9.60	P7019.6X6.0	P6019.6X6.0	P8319.6X6.0
12.70	P70112.7X6.0	P60112.7X6.0	P83112.7X6.0

d ₁ Ø mm	d ₂ Ø _h mm	l ₂ mm	l ₁ mm
3.00	3	14	38
6.30	3	12.7	45
6.00	6	18	50
8.00	6	19	64
9.60	6	19	64
12.70	6	25	70

P803

- Lime rotative - cilindrico con spallamento
- Frässtift- Zylinder mit Stirverzahnung
- Stiffrees - Cilindrisch met kopveranding
- Lime rotative - Cylindrique avec coupe en bout

brasato su 6.00 mm
 Gelötet, wenn der Kopfdurchmesser größer 6 mm ist
 > Ø 6mm gesoldeerd
 Brasée au-dessus de 6,00 mm

P803C

P803; P803C

▪	1.1	1.2	1.3	1.4	1.5	1.6	1.7	1.8	2.1	2.2	2.3	2.4	3.1	3.2	3.3	3.4	4.1	4.2
	4.3	5.1	5.2	5.3	6.2	6.3	6.4	9.1										
•	6.1																	

P803

HM

B



DC

DORMER



P803C

HM

B



DC

DORMER



P803



3.00 - 16.00

P803C



3.00 - 12.70

d ₁ Ø mm	d ₂ Øh ₇ mm	l ₂ mm	l ₁ mm	P803	P803C
3.00	3	14	38	P8033.0X3.0 ¹⁾	P803C3.0X3.0 ¹⁾
6.30	3	12.7	45	P8036.3X3.0	
6.00	6	18	50	P8036.0X6.0 ¹⁾	P803C6.0X6.0 ¹⁾
8.00	6	19	64	P8038.0X6.0	P803C8.0X6.0
9.60	6	19	64	P8039.6X6.0	P803C9.6X6.0
12.70	6	25	70	P80312.7X6.0	P803C12.7X6.0
16.00	6	25	70	P80316.0X6.0	

¹⁾ d2 tolleranza h6 / d2 toleranz h6 / d2 tolerantie h6 / d2 tolérance h6

- P703**
- Lime rotative - cilindrico con spallamento
 - Frässtift- Zylinder mit Stirnverzahnung
- P833**
- Stiffrees - Cilindrisch met kopvertanding
 - Lime rotative - Cylindrique avec coupe en bout

brasato su 6.00 mm
 Gelötet, wenn der Kopfdurchmesser größer 6 mm ist
 > Ø 6mm gesoldeerd
 Brasée au-dessus de 6,00 mm

P703 ■ 1.1 1.2 1.3 1.4 1.5 1.6

P833 ■ 7.1 7.2 7.3 7.4 8.1 8.2 8.3

• 2.1 4.1 5.1 6.2

P703

HM

B



ST

DORMER



P880
525

P833

HM

B



AL

DORMER

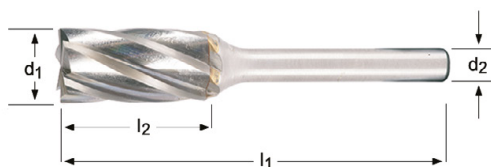

P703



6.00 - 12.70

P833



6.00 - 12.70

d_1 Ø mm	d_2 Øh ₇ mm	l_2 mm	l_1 mm	P703	P833
6.00	6	18	50	P7036.0X6.0 ¹⁾	P8336.0X6.0 ¹⁾
8.00	6	19	64	P7038.0X6.0	
9.60	6	19	64	P7039.6X6.0	P8339.6X6.0
12.70	6	25	70	P70312.7X6.0	P83312.7X6.0

P805

- Lime rotative - cilindrico a punta sferica
- Frässtift- Walzenrund

brasato su 6.00 mm

Gelötet, wenn der Kopfdurchmesser größer 6 mm ist

P805C

- Stiffrees - Ronde walsvorm
- Lime rotative - Cylindrique à bout rond

> Ø 6mm gesoldeerd

Brasée au-dessus de 6,00 mm

P805; P805C	▪	1.1	1.2	1.3	1.4	1.5	1.6	1.7	1.8	2.1	2.2	2.3	2.4	3.1	3.2	3.3	3.4	4.1	4.2
		4.3	5.1	5.2	5.3	6.2	6.3	6.4	9.1										
	•	6.1																	

P805	HM	C			DC			
P805C	HM	C		TiAIN	DC			



d ₁ Ø mm	d ₂ Øh ₇ mm	l ₂ mm	l ₁ mm	P805	P805C
3.00	3	14	38	P8053.0X3.0 ¹⁾	P805C3.0X3.0 ¹⁾
6.30	3	12.7	45	P8056.3X3.0	
6.00	6	18	50	P8056.0X6.0 ¹⁾	P805C6.0X6.0 ¹⁾
8.00	6	19	64	P8058.0X6.0	P805C8.0X6.0
9.60	6	19	64	P8059.6X6.0	P805C9.6X6.0
12.70	6	25	70	P80512.7X6.0	P805C12.7X6.0
16.00	6	25	70	P80516.0X6.0	

¹⁾ d2 tolleranza h6 / d2 toleranz h6 / d2 tolerantie h6 / d2 tolérance h6

- P705** • Lime rotative - cilindrico a punta sferica
P605 • Frässtift- Walzenrund
P835 • Stiffrees - Ronde walsvorm
 • Lime rotative - Cylindrique à bout rond

brasato su 6.00 mm
 Gelötet, wenn der Kopfdurchmesser größer 6 mm ist
 > Ø 6mm gesoldeerd
 Brasée au-dessus de 6,00 mm

P705	▪	1.1	1.2	1.3	1.4	1.5	1.6	
P605	▪	2.1	2.2	2.3	2.4			
P835	▪	7.1	7.2	7.3	7.4	8.1	8.2	8.3
	•	2.1	4.1	5.1	6.2			

P705	HM	C					ST		
P605	HM	C					VA		
P835	HM	C					AL		

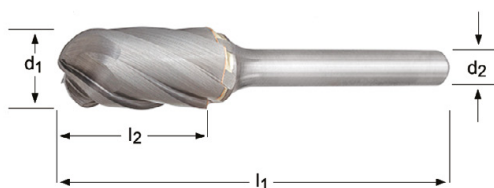

P705	P605	P835
		
6.00 - 12.70	3.00 - 12.70	6.00 - 12.70
P705	P605	P835
	P6053.0X3.0 ¹⁾	
	P6056.3X3.0	
P7056.0X6.0 ¹⁾	P6056.0X6.0 ¹⁾	P8356.0X6.0 ¹⁾
P7058.0X6.0	P6058.0X6.0	
P7059.6X6.0	P6059.6X6.0	P8359.6X6.0
P70512.7X6.0	P60512.7X6.0	P83512.7X6.0

d_1 Ø mm	d_2 Ø _{h7} mm	l_2 mm	l_1 mm
3.00	3	14	38
6.30	3	12.7	45
6.00	6	18	50
8.00	6	19	64
9.60	6	19	64
12.70	6	25	70

P807

- Lime rotative - a palla
- Frässtift- Kugel

brasato su 6.00 mm

Gelötet, wenn der Kopfdurchmesser größer 6 mm ist

P807C

- Stiffrees - Kogelvorm
- Lime rotative - Boule

> Ø 6mm gesoldeerd

Brasée au-dessus de 6,00 mm

P807; P807C	▪	1.1	1.2	1.3	1.4	1.5	1.6	1.7	1.8	2.1	2.2	2.3	2.4	3.1	3.2	3.3	3.4	4.1	4.2	
		4.3	5.1	5.2	5.3	6.2	6.3	6.4	9.1											
	•	6.1																		

P807	HM	D				DC		
P807C	HM	D			TiAlN	DC		

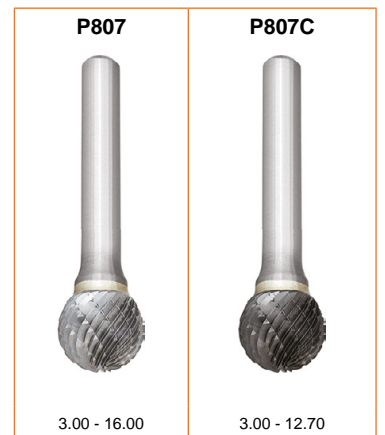
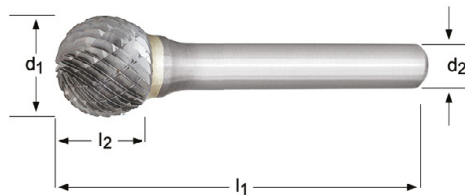

d_1 Ø mm	d_2 Ø _{h7} mm	l_2 mm	l_1 mm	P807	P807C
3.00	3	2.5	38	P8073.0X3.0 ¹⁾	P807C3.0X3.0 ¹⁾
4.00	3	3.4	38	P8074.0X3.0 ¹⁾	
6.30	3	5	38	P8076.3X3.0	
6.00	6	4.7	50	P8076.0X6.0 ¹⁾	P807C6.0X6.0 ¹⁾
8.00	6	6	52	P8078.0X6.0	P807C8.0X6.0
9.60	6	8	54	P8079.6X6.0	P807C9.6X6.0
12.70	6	11	56	P80712.7X6.0	P807C12.7X6.0
16.00	6	14	59	P80716.0X6.0	

¹⁾ d2 tolleranza h6 / d2 toleranz h6 / d2 tolerantie h6 / d2 tolérance h6

- P707** • Lime rotative - a palla
P607 • Frässtift- Kugel
P837 • Stiffrees - Kogelvorm
 • Lime rotative - Boule















brasato su 6.00 mm

Gelötet, wenn der Kopfdurchmesser größer 6 mm ist

> Ø 6mm gesoldeerd

Brasée au-dessus de 6,00 mm

P707	▪	1.1	1.2	1.3	1.4	1.5	1.6	
P607	▪	2.1	2.2	2.3	2.4			
P837	▪	7.1	7.2	7.3	7.4	8.1	8.2	8.3
	•	2.1	4.1	5.1	6.2			

P707	HM	D					ST		
P607	HM	D					VA		
P837	HM	D					AL		

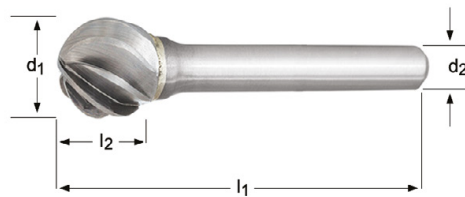

	P707	P607	P837
			
	6.00 - 12.70	3.00 - 12.70	6.00 - 12.70
	P707	P607	P837
		P6073.0X3.0 ¹⁾	
		P6076.3X3.0	
	P7076.0X6.0 ¹⁾	P6076.0X6.0 ¹⁾	P8376.0X6.0 ¹⁾
	P7078.0X6.0	P6078.0X6.0	
	P7079.6X6.0	P6079.6X6.0	P8379.6X6.0
	P70712.7X6.0	P60712.7X6.0	P83712.7X6.0

d ₁ Ø mm	d ₂ Ø _{h₇} mm	l ₂ mm	l ₁ mm	P707	P607	P837
3.00	3	2.5	38		P6073.0X3.0 ¹⁾	
6.30	3	5	38		P6076.3X3.0	
6.00	6	4.7	50	P7076.0X6.0 ¹⁾	P6076.0X6.0 ¹⁾	P8376.0X6.0 ¹⁾
8.00	6	6	52	P7078.0X6.0	P6078.0X6.0	
9.60	6	8	54	P7079.6X6.0	P6079.6X6.0	P8379.6X6.0
12.70	6	11	56	P70712.7X6.0	P60712.7X6.0	P83712.7X6.0

P809

- Lime rotative - ovale
- Frässtift- Tropfen
- Stiffrees - Druppelvorm
- Lime rotative - Ovale

brasato su 6.00 mm
 Gelötet, wenn der Kopfdurchmesser größer 6 mm ist
 > Ø 6mm gesoldeerd
 Brasée au-dessus de 6,00 mm

P809	▪	1.1	1.2	1.3	1.4	1.5	1.6	1.7	1.8	2.1	2.2	2.3	2.4	3.1	3.2	3.3	3.4	4.1	4.2	4.3	5.1
		5.2	5.3	6.2	6.3	6.4	9.1														
	•	6.1																			

P809 **HM** **E**

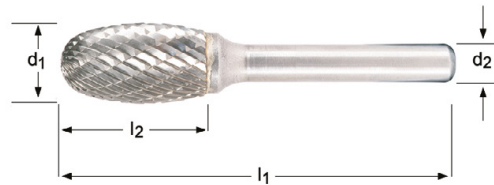

d_1 Ø mm	d_2 Ø _{h7} mm	l_2 mm	l_1 mm	P809
3.00	3	6	38	P8093.0X3.0 ¹⁾
6.30	3	9.5	42	P8096.3X3.0
6.00	6	10	50	P8096.0X6.0 ¹⁾
8.00	6	15	60	P8098.0X6.0
9.60	6	16	60	P8099.6X6.0
12.70	6	22	67	P80912.7X6.0
16.00	6	25	70	P80916.0X6.0

¹⁾ d2 tolleranza h6 / d2 toleranz h6 / d2 tolerantie h6 / d2 tolérance h6

P709

- Lime rotative - ovale
- Frässtift- Tropfen

brasato
Gelötet
gesoldeerd
Brasée

P609

- Stiffrees - Druppelvorm
- Lime rotative - Ovale

P709	▪	1.1	1.2	1.3	1.4	1.5	1.6
P609	▪	2.1	2.2	2.3	2.4		

P709	HM	E					ST	
P609	HM	E					VA	

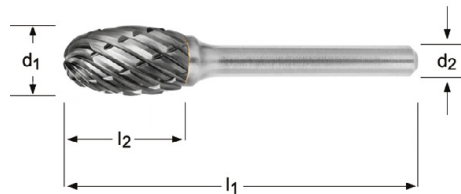

P709	P609
	
12.70	8.00 - 12.70
P709	P609
	P6098.0X6.0
	P6099.6X6.0
P70912.7X6.0	P60912.7X6.0

d_1 Ø mm	d_2 Ø _{h7} mm	l_2 mm	l_1 mm	P709	P609
8.00	6	15	60		P6098.0X6.0
9.60	6	16	60		P6099.6X6.0
12.70	6	22	67	P70912.7X6.0	P60912.7X6.0

P811

- Lime rotative - ad albero a punta sferica
- Frässtift- Rundbogen

brasato su 6.00 mm

Gelötet, wenn der Kopfdurchmesser größer 6 mm ist

P811C

- Stiffrees - Ronde boogvorm
- Lime rotative - Ogive à bout rond

> Ø 6mm gesoldeerd

Brasée au-dessus de 6,00 mm

P811; P811C	▪	1.1	1.2	1.3	1.4	1.5	1.6	1.7	1.8	2.1	2.2	2.3	2.4	3.1	3.2	3.3	3.4	4.1	4.2
		4.3	5.1	5.2	5.3	6.2	6.3	6.4	9.1										
	•	6.1																	

P811	HM	F					DC			P890 526
P811C	HM	F				TiAIN	DC			P880 525



d_1 Ø mm	d_2 Ø _{h7} mm	l_2 mm	l_1 mm	P811	P811C
3.00	3	14	38	P8113.0X3.0 ¹⁾	P811C3.0X3.0 ¹⁾
6.30	3	12.7	45	P8116.3X3.0	
6.00	6	18	50	P8116.0X6.0 ¹⁾	P811C6.0X6.0 ¹⁾
8.00	6	20	65	P8118.0X6.0	
9.60	6	19	64	P8119.6X6.0	P811C9.6X6.0
12.70	6	25	70	P81112.7X6.0	P811C12.7X6.0
16.00	6	25	70	P81116.0X6.0	

¹⁾ d2 tolleranza h6 / d2 toleranz h6 / d2 tolerantie h6 / d2 tolérance h6

- P711** • Lime rotative - ad albero a punta sferica
P611 • Frässtift- Rundbogen
P841 • Stiffrees - Ronde boogvorm
 • Lime rotative - Ogive à bout rond

brasato su 6.00 mm
 Gelötet, wenn der Kopfdurchmesser größer 6 mm ist
 > Ø 6mm gesoldeerd
 Brasée au-dessus de 6,00 mm

P711	▪	1.1	1.2	1.3	1.4	1.5	1.6	
P611	▪	2.1	2.2	2.3	2.4			
P841	▪	7.1	7.2	7.3	7.4	8.1	8.2	8.3
	•	2.1	4.1	5.1	6.2			

P711	HM	F					ST		
P611	HM	F					VA		
P841	HM	F					AL		

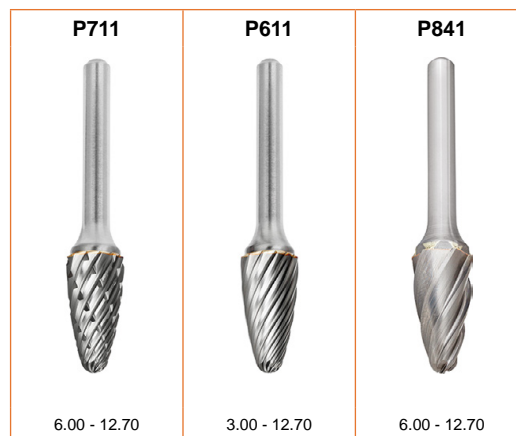
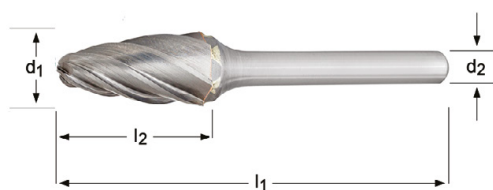

d_1 Ø mm	d_2 Ø _{h₇} mm	l_2 mm	l_1 mm	P711	P611	P841
3.00	3	14	38		P6113.0X3.0 ¹⁾	
6.30	3	12.7	45		P6116.3X3.0	
6.00	6	18	50	P7116.0X6.0 ¹⁾	P6116.0X6.0 ¹⁾	P8416.0X6.0 ¹⁾
8.00	6	20	65	P7118.0X6.0	P6118.0X6.0	
9.60	6	19	64	P7119.6X6.0	P6119.6X6.0	P8419.6X6.0
12.70	6	25	70	P71112.7X6.0	P61112.7X6.0	P84112.7X6.0

¹⁾ d2 tolleranza h6 / d2 toleranz h6 / d2 tolerantie h6 / d2 tolérance h6
 512

P813

- Lime rotative - ad albero a punta
- Frässtift- Spitzbogen

brasato su 6.00 mm

Gelötet, wenn der Kopfdurchmesser größer 6 mm ist

P813C

- Stiffrees - Spitze boogvorm
- Lime rotative - Ogive à bout pointu

> Ø 6mm gesoldeerd

Brasée au-dessus de 6,00 mm

P813; P813C	▪	1.1	1.2	1.3	1.4	1.5	1.6	1.7	1.8	2.1	2.2	2.3	2.4	3.1	3.2	3.3	3.4	4.1	4.2
		4.3	5.1	5.2	5.3	6.2	6.3	6.4	9.1										
	•	6.1																	

P813	HM	G				DC			
P813C	HM	G			TiAIN	DC			

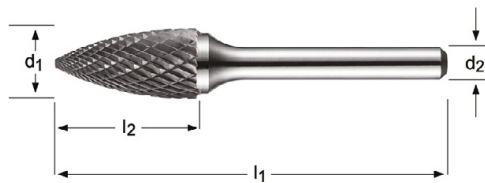

d_1 Ø mm	d_2 Ø _{h7} mm	l_2 mm	l_1 mm	P813	P813C
3.00	3	14	38	P8133.0X3.0 ¹⁾	P813C3.0X3.0 ¹⁾
6.30	3	12.7	45	P8136.3X3.0	
6.00	6	18	50	P8136.0X6.0 ¹⁾	P813C6.0X6.0 ¹⁾
8.00	6	19	64	P8138.0X6.0	
9.60	6	19	64	P8139.6X6.0	P813C9.6X6.0
12.70	6	25	70	P81312.7X6.0	P813C12.7X6.0
16.00	6	25	70	P81316.0X6.0	

¹⁾ d2 tolleranza h6 / d2 toleranz h6 / d2 tolerantie h6 / d2 tolérance h6

- P713**
- Lime rotative - ad albero a punta
 - Frässtift- Spitzbogen
- P613**
- Stiffrees - Spitze boogvorm
 - Lime rotative - Ogive à bout pointu

brasato su 6.00 mm
 Gelötet, wenn der Kopfdurchmesser größer 6 mm ist
 > Ø 6mm gesoldeerd
 Brasée au-dessus de 6,00 mm

P713 ■ 1.1 1.2 1.3 1.4 1.5 1.6

P613 ■ 2.1 2.2 2.3 2.4

P713 HM G     ST 

P613 HM G    VA 



d_1 Ø mm	d_2 Ø _{h7} mm	l_2 mm	l_1 mm	P713	P613
6.00	6	18	50	P7136.0X6.0 ¹⁾	P6136.0X6.0 ¹⁾
8.00	6	19	64	P7138.0X6.0	P6138.0X6.0
9.60	6	19	64	P7139.6X6.0	P6139.6X6.0
12.70	6	25	70	P71312.7X6.0	P61312.7X6.0

P815

- Lime rotative - a fiamma
- Frässtift- Flamme
- Stiffrees - Vlamvorm
- Lime rotative - Flamme

brasato su 6.00 mm
 Gelötet, wenn der Kopfdurchmesser größer 6 mm ist
 > Ø 6mm gesoldeerd
 Brasée au-dessus de 6,00 mm

P815C

- Lime rotative - a fiamma
- Frässtift- Flamme
- Stiffrees - Vlamvorm
- Lime rotative - Flamme

brasato
 Gelötet
 gesoldeerd
 Brasée

P815; P815C	▪	1.1	1.2	1.3	1.4	1.5	1.6	1.7	1.8	2.1	2.2	2.3	2.4	3.1	3.2	3.3	3.4	4.1	4.2
		4.3	5.1	5.2	5.3	6.2	6.3	6.4	9.1										
	•	6.1																	

P815	HM	H					DC	
P815C	HM	H			TiAIN		DC	

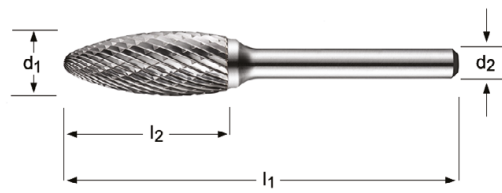

d_1 Ø mm	d_2 Ø _{h7} mm	l_2 mm	l_1 mm	P815	P815C
3.00	3	6	38	P8153.0X3.0 ¹⁾	
6.00	6	14	50	P8156.0X6.0 ¹⁾	
8.00	6	19	64	P8158.0X6.0	P815C8.0X6.0
9.60	6	19	65	P8159.6X6.0	
12.70	6	32	77	P81512.7X6.0	P815C12.7X6.0
16.00	6	36	81	P81516.0X6.0	

¹⁾ d2 tolleranza h6 / d2 toleranz h6 / d2 tolerantie h6 / d2 tolérance h6

P715 • Lime rotative - a fiamma
• Frässtift- Flamme

P615 • Stiffrees - Vlamvorm
• Lime rotative - Flamme

brasato
Gelötet
gesoldeerd
Brasée

P715 ▫ 1.1 1.2 1.3 1.4 1.5 1.6

P615 ▫ 2.1 2.2 2.3 2.4

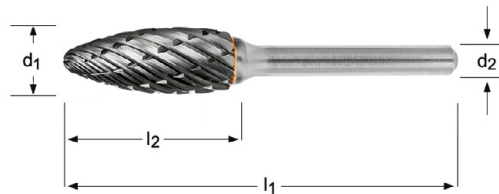

d_1 Ø mm	d_2 Ø _{h7} mm	l_2 mm	l_1 mm	P715	P615
8.00	6	19	64	P7158.0X6.0	P6158.0X6.0
9.60	6	19	65		P6159.6X6.0
12.70	6	32	77	P71512.7X6.0	P61512.7X6.0

P817

- Lime rotative - svasatore a 60°k
- Frässtift- 60° Kegelsenker
- Stiffrees - 60° verzink kegelvorm
- Lime rotative - Fraisure à 60°

brasato su 6.00 mm
 Gelötet, wenn der Kopfdurchmesser größer 6 mm ist
 > Ø 6mm gesoldeerd
 Brasée au-dessus de 6,00 mm

P817	▪	1.1	1.2	1.3	1.4	1.5	1.6	1.7	1.8	2.1	2.2	2.3	2.4	3.1	3.2	3.3	3.4	4.1	4.2	4.3	5.1
		5.2	5.3	6.2	6.3	6.4	9.1														
	•	6.1																			

P817 **HM** **J** **DC**



d_1 Ø mm	d_2 Øh ₇ mm	l_2 mm	l_1 mm	P817
3.00	3	2.5	38	P8173.0X3.0 ¹⁾
6.00	6	4	50	P8176.0X6.0 ¹⁾
9.60	6	8	56	P8179.6X6.0
12.70	6	11	59	P81712.7X6.0
16.00	6	14.5	63	P81716.0X6.0

¹⁾ d2 tolleranza h6 / d2 toleranz h6 / d2 tolerantie h6 / d2 tolérance h6

P819

- Lime rotative - svasatore a 90°k
- Frässtift- 90° Kegelsenker
- Stiffrees - 90° verzinkt kegelvorm
- Lime rotative - Fraisure à 90°

brasato su 6.00 mm
 Gelötet, wenn der Kopfdurchmesser größer 6 mm ist
 > Ø 6mm gesoldeerd
 Brasée au-dessus de 6,00 mm

P819	▪	1.1	1.2	1.3	1.4	1.5	1.6	1.7	1.8	2.1	2.2	2.3	2.4	3.1	3.2	3.3	3.4	4.1	4.2	4.3	5.1	
		5.2	5.3	6.2	6.3	6.4	9.1															
		• 6.1																				

P819 HM K    90° DC 

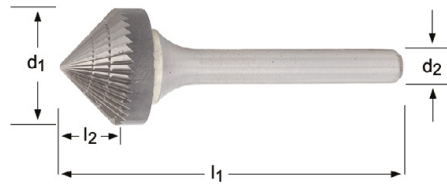

d ₁ Ø mm	d ₂ Øh ₇ mm	l ₂ mm	l ₁ mm	P819
3.00	3	1.5	38	P8193.0X3.0 ¹⁾
6.00	6	3	50	P8196.0X6.0 ¹⁾
9.60	6	4.7	53	P8199.6X6.0
12.70	6	6.3	55	P81912.7X6.0
16.00	6	8	57	P81916.0X6.0

¹⁾ d2 tolleranza h6 / d2 toleranz h6 / d2 tolerantie h6 / d2 tolérance h6
 518

P821

- Lime rotative - conico a palla
- Frässtift- Rundkegel

brasato su 6.00 mm

Gelötet, wenn der Kopfdurchmesser größer 6 mm ist

P821C

- Stiffrees - Ronde kegelvorm
- Lime rotative - Conique à bout rond

> Ø 6mm gesoldeerd

Brasée au-dessus de 6,00 mm

P821; P821C	▪	1.1	1.2	1.3	1.4	1.5	1.6	1.7	1.8	2.1	2.2	2.3	2.4	3.1	3.2	3.3	3.4	4.1	4.2
		4.3	5.1	5.2	5.3	6.2	6.3	6.4	9.1										
	•	6.1																	

P821	HM	L				DC		
P821C	HM	L			TiAIN	DC		

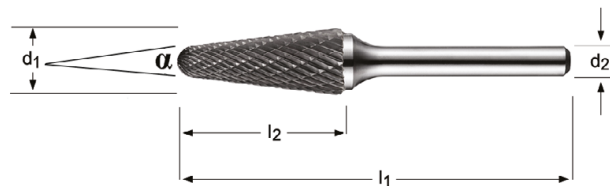

d_1 Ø mm	d_2 Ø _{h7} mm	l_2 mm	l_1 mm	α	P821	P821C
3.00	3	14	38	8°	P8213.0X3.0 ¹⁾	P821C3.0X3.0 ¹⁾
6.00	6	18	50	14°	P8216.0X6.0 ¹⁾	
8.00	6	25.4	70	14°	P8218.0X6.0	
9.60	6	30	76	14°	P8219.6X6.0	
12.70	6	32	77	14°	P82112.7X6.0	P821C12.7X6.0
16.00	6	33	78	14°	P82116.0X6.0	

¹⁾ d2 tolleranza h6 / d2 toleranz h6 / d2 tolerantie h6 / d2 tolérance h6

- P721**
- Lime rotative - conico a palla
 - Frässtift- Rundkegel
- P621**
- Stiffrees - Ronde kegelvorm
 - Lime rotative - Conique à bout rond

brasato
Gelötet
gesoldeerd
Brasée

- P842**
- Lime rotative - conico a palla
 - Frässtift- Rundkegel
 - Stiffrees - Ronde kegelvorm
 - Lime rotative - Conique à bout rond

brasato su 6.00 mm
Gelötet, wenn der Kopfdurchmesser größer 6 mm ist
> Ø 6mm gesoldeerd
Brasée au-dessus de 6,00 mm

P721	▪	1.1	1.2	1.3	1.4	1.5	1.6	
P621	▪	2.1	2.2	2.3	2.4			
P842	▪	7.1	7.2	7.3	7.4	8.1	8.2	8.3
	•	2.1	4.1	5.1	6.2			

P721	HM	L					ST		
P621	HM	L					VA		
P842	HM	L					AL		



	P721	P621	P842
			
	10.00 - 12.70	8.00 - 12.70	6.00 - 12.70
	P721	P621	P842
			P8426.0X6.0 ¹⁾
	P72110.0X6.0 P7219.6X6.0 P72112.7X6.0	P6218.0X6.0 P62110.0X6.0 P62112.7X6.0	P8429.6X6.0 P84212.7X6.0

d_1 Ø mm	d_2 Ø _{h7} mm	l_2 mm	l_1 mm				
6.00	6	18	50	14°			P8426.0X6.0 ¹⁾
8.00	6	25.4	70	14°			
10.00	6	20	65	14°	P72110.0X6.0	P62110.0X6.0	
9.60	6	30	76	14°	P7219.6X6.0		P8429.6X6.0
12.70	6	32	77	14°	P72112.7X6.0	P62112.7X6.0	P84212.7X6.0

P823

- Lime rotative - conico
- Frässtift- Spitzkegel
- Stiffrees - Spitze kegelvorn
- Lime rotative - Conique à bout rond

brasato su 6.00 mm
 Gelötet, wenn der Kopfdurchmesser größer 6 mm ist
 > Ø 6mm gesoldeerd
 Brasée au-dessus de 6,00 mm

P823	▪	1.1	1.2	1.3	1.4	1.5	1.6	1.7	1.8	2.1	2.2	2.3	2.4	3.1	3.2	3.3	3.4	4.1	4.2	4.3	5.1	
		5.2	5.3	6.2	6.3	6.4	9.1															
	•	6.1																				

P823 **HM** **M** **DC**

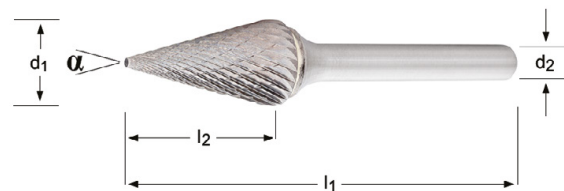

d_1 Ø mm	d_2 Ø _{h7} mm	l_2 mm	l_1 mm		P823
3.00	3	11	38	14°	P8233.0X3.0 ¹⁾
6.30	3	12.7	49	22°	P8236.3X3.0
6.00	6	20	50	14°	P8236.0X6.0 ¹⁾
9.60	6	16	64	28°	P8239.6X6.0
12.70	6	22	71	28°	P82312.7X6.0
16.00	6	25	71	31°	P82316.0X6.0

¹⁾ d2 tolleranza h6 / d2 toleranz h6 / d2 tolerantie h6 / d2 tolérance h6

P825

- Lime rotative - conico invertito
- Frässtift- umgekehrter Kegel
- Stiffrees - Omgekeerde kegelvorm
- Lime rotative - Conique inverse

brasato su 6.00 mm
 Gelötet, wenn der Kopfdurchmesser größer 6 mm ist
 > Ø 6mm gesoldeerd
 Brasée au-dessus de 6,00 mm

P825	▪	1.1	1.2	1.3	1.4	1.5	1.6	1.7	1.8	2.1	2.2	2.3	2.4	3.1	3.2	3.3	3.4	4.1	4.2	4.3	5.1	
		5.2	5.3	6.2	6.3	6.4	9.1															
	•	6.1																				

P825

HM

N



DC

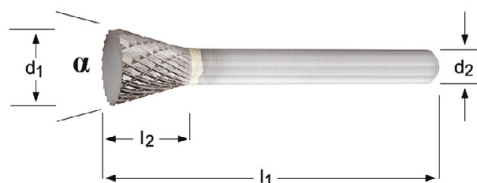

P825



3.00 - 16.00

d_1 Ø mm	d_2 Ø _{h7} mm	l_2 mm	l_1 mm	▷	P825
3.00	3	4	38	10°	P8253.0X3.0 ¹⁾
6.30	3	6	39	12°	P8256.3X3.0
6.00	6	8	50	10°	P8256.0X6.0 ¹⁾
9.60	6	9.5	55	16°	P8259.6X6.0
12.70	6	12.7	58	28°	P82512.7X6.0
16.00	6	19	64	18°	P82516.0X6.0

¹⁾ d2 tolleranza h6 / d2 toleranz h6 / d2 tolerantie h6 / d2 tolérance h6

- P843**
- Fresa verticale diamantata – punta di foratura a 135°
 - Diamantfräser – Verzahnung – 135°-Bohrschneide
 - Router – 135° punthoek
 - Fraise à taille diamant – Pointe de foret 135°

P843 ■ 8.1 8.2 8.3

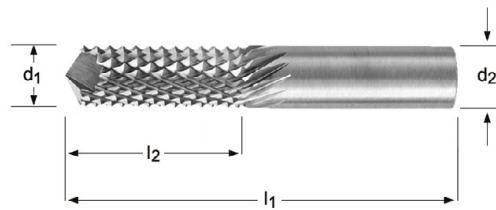

d_1 Ø mm	d_2 Ø _{h₆} mm	l_2 mm	l_1 mm	P843
3.00	3	13	45	P8433.0X3.0
6.00	6	19	63	P8436.0X6.0
8.00	8	25	63	P8438.0X8.0

P844

- Fresa verticale diamantata – fresa frontale
- Diamantfräser – Verzahnung – 180°-Bohrschneide
- Router – Tweesnijder
- Fraise à taille diamant – Fraise de finition

P844 ■ 8.1 8.2 8.3

P844

HM



180°

GRP

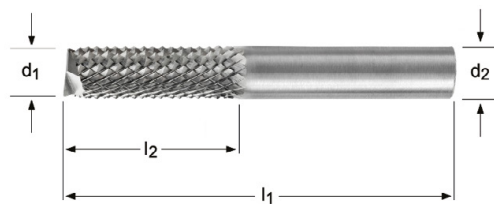

P844



3.00 - 8.00

d_1 Ø mm	d_2 Ø _{h6} mm	l_2 mm	l_1 mm	P844
3.00	3	13	45	P8443.0X3.0
6.00	6	19	63	P8446.0X6.0
8.00	8	25	63	P8448.0X8.0

P880

- set Lime rotative
- Frässtife-Satz
- Stiffrees - Set
- Set de limes rotatives

A=Tipi in serie, B=No. punte in Set, C=diametri in Set
 A=Typen in Satz, B=Stücken, C=Durchmesser im Satz
 A=Type, B=Aantal, C=Diameters
 A=Types de coffrets, B=Nombre dans le coffret, C=Diamètres dans le coffret



Nr.	A	B	C	P880
Nr01	P803 + P805 + P807 + P809 + P813	5	P8039.6X6.0, P8059.6X6.0, P8079.6X6.0, P8099.6X6.0, P8139.6X6.0	P88001
Nr02	P803C + P805C + P807C + P811C + P813C	5	P803C9.6X6.0, P805C9.6X6.0, P807C9.6X6.0, P811C9.6X6.0, P813C9.6X6.0	P88002
Nr03	P601 + P605 + P607 + P611 + P621	5	P6019.6X6.0, P6059.6X6.0, P6079.6X6.0, P6119.6X6.0, P62110.0X6.0	P88003
Nr04	P703 + P705 + P707 + P711 + P721	5	P7039.6X6.0, P7059.6X6.0, P7079.6X6.0, P7119.6X6.0, P72110.0X6.0	P88004

P890

- Espositore lime rotative
- Frässtiftesponder
- Stiffrees - Display
- Présentoir de limes rotatives

A=Tipi in serie, B=No. punte in Set, C=diametri in Set
 A=Typen in Satz, B=Stücken, C=Durchmesser im Satz
 A=Type, B=Aantal, C=Diameters

A=Types de coffrets, B=Nombre dans le coffret, C=Diamètres dans le coffret



Nr.	A	B	C	P890
Nr01	P803 + P805 + P811 + P813 + P821	40	P803(6.0X6.0, 8.0X6.0, 9.6X6.0, 12.7X6.0) X 2, P805(6.0X6.0, 8.0X6.0, 9.6X6.0, 12.7X6.0) X 2, P811(6.0X6.0, 8.0X6.0, 9.6X6.0, 12.7X6.0) X 2, P813(6.0X6.0, 8.0X6.0, 9.6X6.0, 12.7X6.0) X 2, P821(6.0X6.0, 8.0X6.0, 9.6X6.0, 12.7X6.0) X 2	P89001

K100	536	K305	533
K101	536	K310	534
K102	536	K311	534
K103	537	K312	534
K104	537	K313	534
K200	538	K314	534
K201	538	K330	535
K202	538	K520	539
K203	538	K521	540
K204	538	K522	541
K300	533	M150	542
K301	533	M151	543
K302	533	M152	544
K303	533	M200	545
K304	533		

527 - 546

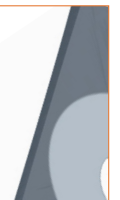
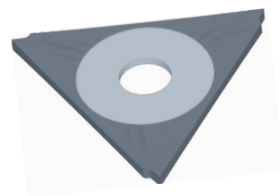

Materiale	Material	Materiaal	Matière
Trattamento superficiale	Oberfläche	Oppervlaktebehandeling	Revêtement
Normativa	Standard	Norm	Standard
Inclinazione tagliente	Abstechwinkel	Afsteekhoek	Angle de coupe
Applicazione	Anwendung	Toepassing	Utilisation
Senso di rotazione	Abstechrichtung	Snijrichting	Direction de coupe
Larghezza inserto	Plattengröße	Grootte	Taille
■ Raccomandato	Sehr gut für die Anwendung	Uitstekend voor deze toepassing	Excellent pour les applications
● Accettabile	Gut für die Anwendung	Acceptabel voor deze toepassing	Acceptable pour les applications
Esempio 10 = Velocità periferica in m/min +/- 10%	Beispiel 10 = Schnittgeschwindigkeit (m/min) +/- 10 %	Voorbeeld 10= snijnsnelheid in m/min +/-10%	Exemple 10 = Vitesse périphérique en mètres/ minute +/- 10%
Codice prodotto	Produktbezeichnung	Productcode	Codes
Gamma diametri	Durchmesserbereich	Diameterreeks	Gamme

AMG	Italiano	Deutsch	Nederlands	Français
1.1	Acciaio dolce magnetico	Magnetweicheisen	Automatenstaal, zachtstaal	Acier doux magnétique
1.2	Acciaio da costruzione e da cementazione	Baustahl, Einsatzstahl	Constructiestaal, inzetstaal	Acier de construction, Acier de cémentation
1.3	Acciaio al carbonio	Kohlenstoffstahl	Koolstofstaal	Acier au carbone ordinaire
1.4	Acciaio legato	Legierter Stahl	Gelegeerd staal	Acier allié
1.5	Acciaio legato / Acciaio bonificato e temprato	Legierter und vergüteter Stahl	Gelegeerd en veredeld staal	Acier allié/ Acier trempé et revenu
1.6	Acciaio legato / Acciaio bonificato e temprato	Legierter und vergüteter Stahl	Hooggelegeerd veredeld staal	Acier allié/ Acier trempé et revenu
1.7	Acciaio legato/temprato	Legierter gehärteter Stahl	Gelegeerd en gehard staal	Acier allié trempé
1.8	Acciaio legato/temprato	Legierter gehärteter Stahl	Gelegeerd en gehard staal	Acier allié trempé
2.1	Acciaio inossidabile/automatico	Rostfreier Stahl, geschwefelt	Roestvast automatenstaal	Acier inoxydable de décolletage
2.2	Austenitico	Austenitisch	Austenitisch	Austénitique
2.3	Ferritico+Austenitico, Martensitico	Ferritisch+Austenitisch, Martensitisch	Ferritisch+Austenitisch, Martensitisch	Ferritique + Austénitique, Martensitique
2.4	Acciai inossidabili con indurimento da precipitazione	Vergüteter rostfreier Stahl	Precipitatiehardend roestvast staal	Acier inoxydable Trempé
3.1	Ghisa con grafite lamellare	Grauguss	Gietijzer Lamellair	Graphite lamellaire
3.2	Ghisa con grafite lamellare	Vergüteter Grauguss	Gietijzer Lamellair	Graphite lamellaire
3.3	Ghisa malleabile con grafite sferoidale	Kugelgraphitguss, Temperguss	Nodulair gietijzer / Smeedbaar gietijzer	Graphite nodulaire/ Fonte malléable
3.4	Ghisa malleabile con grafite sferoidale	Kugelgraphitguss, Temperguss	Nodulair gietijzer / Smeedbaar gietijzer	Graphite nodulaire/ Fonte malléable
4.1	Titanio non legato	Reintitan	Titaan, ongelegeerd	Titane, non-allié
4.2	Leghe di titanio	Titan-Legierungen	Titaan, gelegeerd	Titane, allié
4.3	Leghe di titanio	Titan-Legierungen	Titaan, gelegeerd	Titane, allié
5.1	Nichel non legato	Reinnickel	Nikkel, ongelegeerd	Nickel, non-allié
5.2	Leghe di nichel	Nickel-Legierungen	Nikkel, gelegeerd	Nickel, allié
5.3	Leghe di nichel	Nickel-Legierungen	Nikkel, gelegeerd	Nickel, allié
6.1	6.1 Rame	Kupfer	Koper	Cuivre
6.2	β-Ottone, Bronzo	Kurzspanendes Messing, Bronze	β-Messing, brons	β-Laiton, Bronze
6.3	α-Ottone	Langspanendes Messing	α-Messing	α-Laiton
6.4	Bronzo ad alta resistenza	Cu-Al-Fe-Legierung, (Ampco)	Extra-sterk brons	Bronze, haute résistance
7.1	Al, Mg, non legato	Al, Mg, unlegiert	Al, Mg, ongelegeerd	Al, Mg, non-allié
7.2	Leghe di Al, Si < 0.5%	Al legiert, Si<0.5 %	Al gelegeerd, Si < 0.5%	Al allié, Si < 0.5%
7.3	Leghe di Al, Si > 0.5% < 10%	Al legiert, Si>0.5 %<10 %	Al gelegeerd, Si > 0.5% < 10%	Al allié, Si > 0.5% < 10%
7.4	Leghe di Al, Si > 10% Rinforzate Whisker Leghe di Al, Leghe di Mg	Al legiert, Si>10 % Whisker verstärkte Al-Legierung, Mg-Legierung	Al gelegeerd, Si>10% whisker versterkt Al-Legierungen, Mg-Legierungen	Al allié, Si>10% Alliages d'Al ou Mg, céramique renforcée
8.1	Materiali termoplastici	Thermoplaste	Thermoplasten	Thermoplastiques
8.2	Materiali plastici termoindurenti	Duroplaste	Duraplasten	Plastiques thermodurcissables
8.3	Materiali plastici rinforzati	Faserverstärkte Kunststoffe	Versterkte kunststofmaterialen	Plastiques renforcés
9.1	Cermets (materiali metallo-ceramici)	Cermets (Metallkeramik)	Cermets (metal-ceramics)	Cermets (céramiques métalliques)
10.1	Grafite standard	Graphit	Standaard Grafiet	Graphite standard

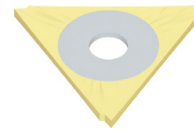
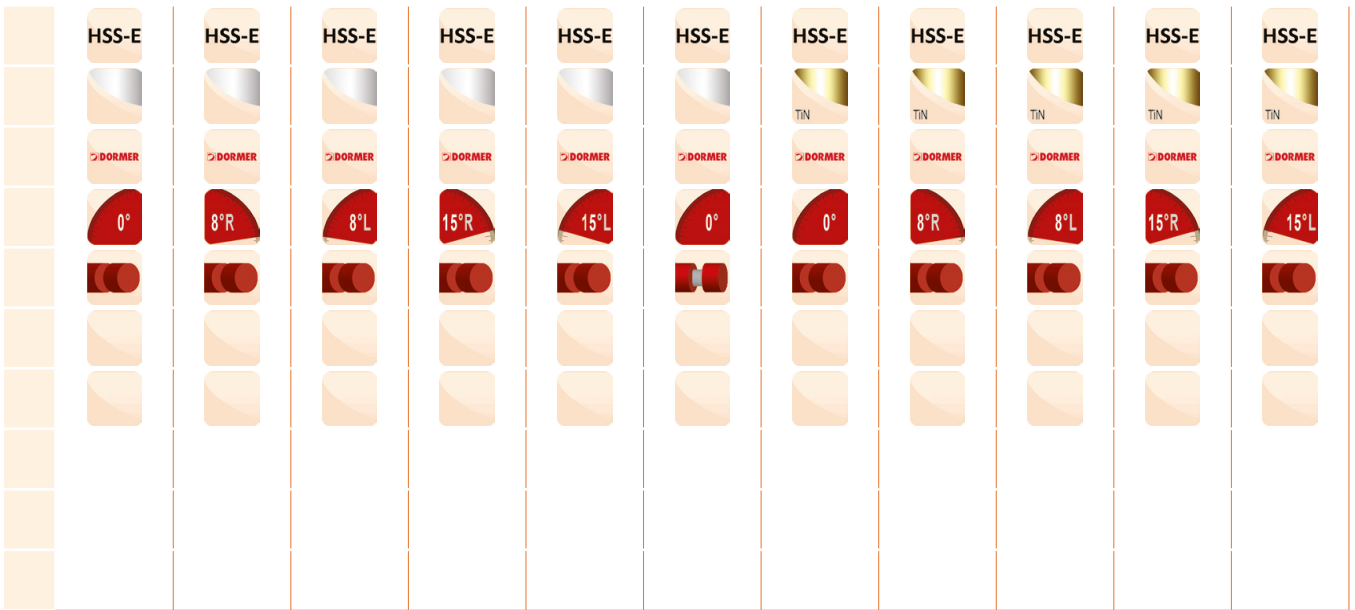

	K300	K301	K302	K303	K304	K305	K310	K311	K312	K313	K314
	1.50 - 2.50	1.50 - 2.50	1.50 - 2.50	1.50 - 2.50	1.50 - 2.50	1.10 - 2.15	23.00 - 40.00	23.00 - 40.00	23.00 - 40.00	23.00 - 40.00	23.00 - 40.00

AMG	533	533	533	533	533	533	534	534	534	534	534	ISO
1.1	■50A	■50A	■50A	■50A	■50A	■50A	■120A	■120A	■120A	■120A	■120A	P 1
1.2	■40B	■40B	■40B	■40B	■40B	■40B	■100B	■100B	■100B	■100B	■100B	P 1
1.3	●30C	●30C	●30C	●30C	●30C	●30C	●60C	●60C	●60C	●60C	●60C	P 2
1.4	●20D	●20D	●20D	●20D	●20D	●20D	●50D	●50D	●50D	●50D	●50D	P 3
1.5							●20E	●20E	●20E	●20E	●20E	P 4
1.6												H 1
1.7												H 3
1.8												H 4
2.1	●15C	●15C	●15C	●15C	●15C	●15C	■20C	■20C	■20C	■20C	■20C	M 1
2.2							■20C	■20C	■20C	■20C	■20C	M 3
2.3							●10B	●10B	●10B	●10B	●10B	M 2
2.4												S 2
3.1												K 1
3.2												K 2
3.3												K 3
3.4												K 4
4.1												S 1
4.2												S 2
4.3												S 3
5.1												S 1
5.2												S 2
5.3												S 3
6.1	●100B	●100B	●100B	●100B	●100B	●100B	■250B	■250B	■250B	■250B	■250B	N 3
6.2	■65C	■65C	■65C	■65C	■65C	■65C	■160C	■160C	■160C	■160C	■160C	N 4
6.3	■100B	■100B	■100B	■100B	■100B	■100B	■250B	■250B	■250B	■250B	■250B	N 3
6.4												N 4
7.1	●150A	●150A	●150A	●150A	●150A	●150A	■370A	■370A	■370A	■370A	■370A	N 1
7.2	●150B	●150B	●150B	●150B	●150B	●150B	■370B	■370B	■370B	■370B	■370B	N 1
7.3							■110C	■110C	■110C	■110C	■110C	N 1
7.4							●45D	●45D	●45D	●45D	●45D	N 2
8.1												O
8.2												O
8.3												O
9.1												H
10.1												O

	23mm	40mm
A	0.20	0.25
B	0.15	0.20
C	0.10	0.15
D	0.05	0.10
E	0.03	0.05

	23mm	40mm
A	0.20	0.25
B	0.15	0.20
C	0.10	0.15
D	0.05	0.10
E	0.03	0.05

HSS-E



DORMER



K330

23.00 - 40.00



23mm



23mm



23mm



40mm



40mm



K100

10.00 - 20.00



K101

12.00 - 20.00



K102

10.00 - 14.00



K103

16.00 - 32.00



K104

16.00 - 32.00

AMG



535

- 120A
- 100B
- 60C
- 50D
- 20E

- 20C
- 20C
- 10B

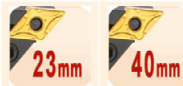

A	0.20	0.25
B	0.15	0.20
C	0.10	0.15
D	0.05	0.10
E	0.03	0.05

- 250B
- 160C
- 250B

- 370A
- 370B
- 110C
- 45D

536

536

536

537

537

ISO

1.1										P 1
1.2										P 1
1.3										P 2
1.4										P 3
1.5										P 4
1.6										H 1
1.7										H 3
1.8										H 4
2.1										M 1
2.2										M 3
2.3										M 2
2.4										S 2
3.1										K 1
3.2										K 2
3.3										K 3
3.4										K 4
4.1										S 1
4.2										S 2
4.3										S 3
5.1										S 1
5.2										S 2
5.3										S 3
6.1										N 3
6.2										N 4
6.3										N 3
6.4										N 4
7.1										N 1
7.2										N 1
7.3										N 1
7.4										N 2
8.1										O
8.2										O
8.3										O
9.1										H
10.1										O

						HSS-E	HSS-E	HSS-E	
						DIN 4964 B	DIN 4964 A	DIN 4964 D	
						h13	h9	h13	
	K200	K201	K202	K203	K204	K520	K521	K522	
	1.50	1.50	1.50	2.50	2.50	4.00 - 5/8"	3.00 - 20	10.00 - 25	
AMG	538	538	538	538	538	539	540	541	ISO
1.1						■80A	■80A	■80A	P 1
1.2						■80A	■80A	■80A	P 1
1.3						■65A	■65A	■65A	P 2
1.4						■55A	■55A	■55A	P 3
1.5						●35A	●35A	●35A	P 4
1.6									H 1
1.7									H 3
1.8									H 4
2.1						●37A	●37A	●37A	M 1
2.2						●30A	●30A	●30A	M 3
2.3									M 2
2.4									S 2
3.1						■60A	■60A	■60A	K 1
3.2						■50A	■50A	■50A	K 2
3.3						■40A	■40A	■40A	K 3
3.4						■25A	■25A	■25A	K 4
4.1									S 1
4.2									S 2
4.3									S 3
5.1									S 1
5.2									S 2
5.3									S 3
6.1						■100A	■100A	■100A	N 3
6.2						■65A	■65A	■65A	N 4
6.3						■100A	■100A	■100A	N 3
6.4						●50A	●50A	●50A	N 4
7.1						●120A	●120A	●120A	N 1
7.2						●150A	●150A	●150A	N 1
7.3									N 1
7.4									N 2
8.1									O
8.2									O
8.3									O
9.1									H
10.1									O

	M150	M151	M152	M200	M200	M200	ISO
	542	543	544	545	545	545	
1.1				■			P 1
1.2				■		●	P 1
1.3				■		●	P 2
1.4				■		●	P 3
1.5				■		■	P 4
1.6				■		■	H 1
1.7				●		■	H 3
1.8				●		■	H 4
2.1				■		■	M 1
2.2				■		■	M 3
2.3				■		■	M 2
2.4				●		■	S 2
3.1				■		●	K 1
3.2				■		●	K 2
3.3				■		●	K 3
3.4				■		●	K 4
4.1				■		■	S 1
4.2				■		■	S 2
4.3				■		■	S 3
5.1				■		■	S 1
5.2				■		■	S 2
5.3				■		■	S 3
6.1					●		N 3
6.2					●		N 4
6.3					●		N 3
6.4					●		N 4
7.1					■		N 1
7.2					■		N 1
7.3					■		N 1
7.4					■		N 2
8.1							O
8.2							O
8.3							O
9.1							H
10.1							O

K300

- Insetti per troncatura
- Abstech-Wendeschneidplatte
- Type wisselplaat
- Plaquettes de tronçonnage



K301

- Insetti per troncatura
- Abstech-Wendeschneidplatte
- Type wisselplaat
- Plaquettes de tronçonnage



K302

- Insetti per troncatura
- Abstech-Wendeschneidplatte
- Type wisselplaat
- Plaquettes de tronçonnage



K303

- Insetti per troncatura
- Abstech-Wendeschneidplatte
- Type wisselplaat
- Plaquettes de tronçonnage



K304

- Insetti per troncatura
- Abstech-Wendeschneidplatte
- Type wisselplaat
- Plaquettes de tronçonnage



K305

- Insetti per troncatura
- Abstech-Wendeschneidplatte
- Type wisselplaat
- Plaquettes de tronçonnage



K300; K301; K302; K303; K304; K305 ■ 1.1 1.2 6.2 6.3
 • 1.3 1.4 2.1 6.1 7.1 7.2

K300	HSS-E						
K301	HSS-E						
K302	HSS-E						
K303	HSS-E						
K304	HSS-E						
K305	HSS-E						

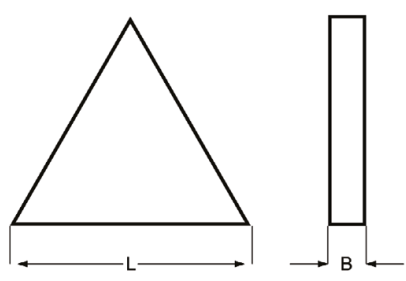

	K300	K301	K302	K303	K304	K305
	1.50 - 2.50	1.50 - 2.50	1.50 - 2.50	1.50 - 2.50	1.50 - 2.50	1.10 - 2.15

L	B	d min-max mm	K300	K301	K302	K303	K304	K305
23	1.10	9 - 17						K30523.0X1.1
23	1.30	18 - 26						K30523.0X1.3
23	1.50		K30023.0X1.5	K30123.0X1.5	K30223.0X1.5	K30323.0X1.5	K30423.0X1.5	
23	1.60	28 - 35						K30523.0X1.6
40	1.85	36 - 48						K30540.0X1.85
40	2.15	50 - 63						K30540.0X2.15
40	2.50		K30040.0X2.5	K30140.0X2.5	K30240.0X2.5	K30340.0X2.5	K30440.0X2.5	

K310

- Insetti per troncatura
- Abstech-Wendeschneidplatte
- Type wisselplaat
- Plaquettes de tronçonnage



K311

- Insetti per troncatura
- Abstech-Wendeschneidplatte
- Type wisselplaat
- Plaquettes de tronçonnage



K312

- Insetti per troncatura
- Abstech-Wendeschneidplatte
- Type wisselplaat
- Plaquettes de tronçonnage



K313

- Insetti per troncatura
- Abstech-Wendeschneidplatte
- Type wisselplaat
- Plaquettes de tronçonnage



K314

- Insetti per troncatura
- Abstech-Wendeschneidplatte
- Type wisselplaat
- Plaquettes de tronçonnage



K310; K311; K312; K313; K314	▪	1.1	1.2	1.3	2.1	2.2	6.1	6.2	6.3	7.1	7.2	7.3
	•	1.4	1.5	2.3	7.4							

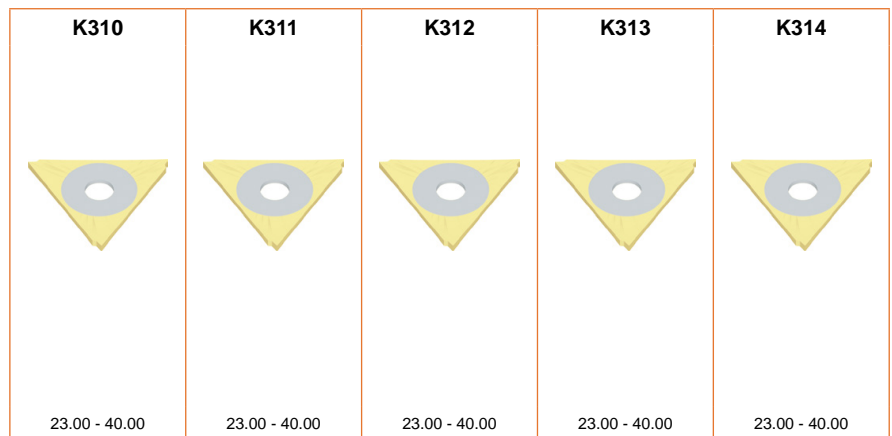
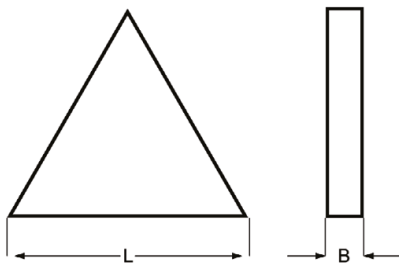

L	B	K310	K311	K312	K313	K314
23	1.50	K31023.0X1.5	K31123.0X1.5	K31223.0X1.5	K31323.0X1.5	K31423.0X1.5
40	2.50	K31040.0X2.5	K31140.0X2.5	K31240.0X2.5	K31340.0X2.5	K31440.0X2.5

K330

- Inserti per troncatura
- Abstech-Wendeschneidplatte
- Type wisselplaat
- Plaquettes de tronçonnage



K330	▪	1.1	1.2	1.3	2.1	2.2	6.1	6.2	6.3	7.1	7.2	7.3
	•	1.4	1.5	2.3	7.4							

K330 HSS-E TiAIN DORMER 0°

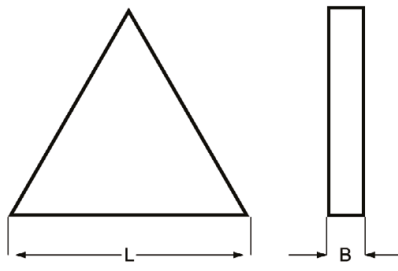

K330

23.00 - 40.00

L	B	K330
23	1.50	K33023.0X1.5

- K100** • Portainseri
- K101** • Abstechhalter
- K102** • Wisselplaathouder
- Porte-outils pour plaquettes

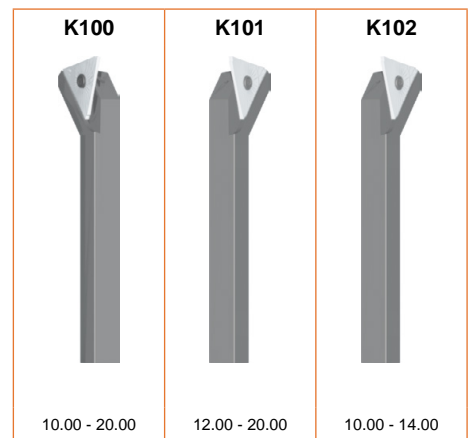
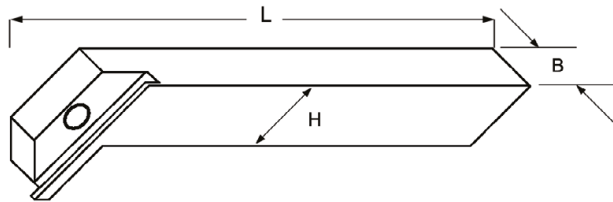

H	B	L	K100	K101	K102
10	10	125	K10010.0		K10210.0
12	12	125	K10012.0	K10112.0	
20	12	125	K10020.0	K10120.0	

- K103** • Portainseriti
• Abstechhalter
- K104** • Wisselplaathouder
• Porte-outils pour plaquettes

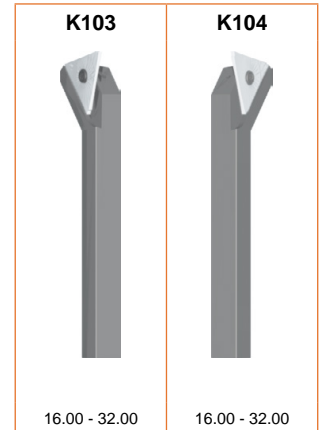
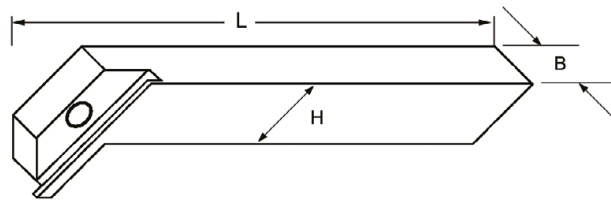

H	B	L	K103	K104
16	16	140	K10316.0	K10416.0
25	16	140	K10325.0	K10425.0

- K200** • Parti di ricambio per portainseri
- K201** • Ersatzteile für Abstechwerkzeuge
- K202** • Onderdelen voor wisselplaathouders
- K203** • Pièces de rechange pour outil à tronçonner
- K204** • Pièces de rechange pour outil à tronçonner



size	tool code	K200	K201	K202	K203	K204
1.5	Excentric	K200ECC1.5				
1.5	Spanner		K201SPAN1.5			
1.5-2.5	Pin			K2022.5X12.0		
2.5	Excentric				K203ECC2.5	
2.5	Spanner					K204SPAN2.5

K520

- Barrette sezione quadra h13
- Drehlinge Vierkant h13
- Toolbits Vierkant h13
- Barreaux rectifiés Carré h13

K520	▪	1.1	1.2	1.3	1.4	3.1	3.2	3.3	3.4	6.1	6.2	6.3
	•	1.5	2.1	2.2	6.4	7.1	7.2					

K520 HSS-E

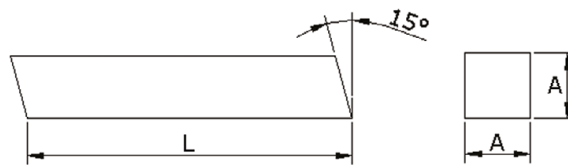

A	L	K520
4	100	K5204.0X100.0
5	160	K5205.0X160.0
6	100	K5206.0X100.0
6	160	K5206.0X160.0
6	200	K5206.0X200.0
8	100	K5208.0X100.0
8	160	K5208.0X160.0
8	200	K5208.0X200.0
10	100	K52010.0X100.0
10	160	K52010.0X160.0
10	200	K52010.0X200.0
12	100	K52012.0X100.0
12	160	K52012.0X160.0
12	200	K52012.0X200.0
14	160	K52014.0X160.0
14	200	K52014.0X200.0
16	100	K52016.0X100.0
16	160	K52016.0X160.0
16	200	K52016.0X200.0
20	160	K52020.0X160.0
20	200	K52020.0X200.0
25	200	K52025.0X200.0
3/16	2.1/2	K5203/16X2.1/2
1/4	2.1/2	K5201/4X2.1/2
1/4	4"	K5201/4X4
5/16	2.1/2	K5205/16X2.1/2
5/16	3"	K5205/16X3
5/16	4"	K5205/16X4
3/8	3"	K5203/8X3
3/8	4"	K5203/8X4
3/8	6"	K5203/8X6
7/16	3.1/2	K5207/16X3.1/2
1/2	4"	K5201/2X4
1/2	6"	K5201/2X6
5/8	4.1/2	K5205/8X4.1/2
5/8	6"	K5205/8X6

K521

- Barrette sezione circolare h9
- Drehlinge Rund h9
- Toolbits Rond h9
- Barreaux rectifiés Rond h9

K521	▪	1.1	1.2	1.3	1.4	3.1	3.2	3.3	3.4	6.1	6.2	6.3
	•	1.5	2.1	2.2	6.4	7.1	7.2					

K521 HSS-E   

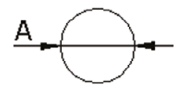
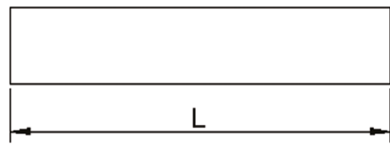

A	L	K521
3	100	K5213.0X100.0
4	100	K5214.0X100.0
5	160	K5215.0X160.0
6	100	K5216.0X100.0
6	160	K5216.0X160.0
8	100	K5218.0X100.0
8	160	K5218.0X160.0
8	200	K5218.0X200.0
10	100	K52110.0X100.0
10	200	K52110.0X200.0
12	100	K52112.0X100.0
12	200	K52112.0X200.0
14	200	K52114.0X200.0
16	200	K52116.0X200.0
20	200	K52120.0X200.0

K522

- Barrette sezione rettangolare h13
- Drehlinge Rechteck h13
- Toolbits Rechthoek h13
- Barreaux rectifiés Rectangle h13

K522	▪	1.1	1.2	1.3	1.4	3.1	3.2	3.3	3.4	6.1	6.2	6.3
	•	1.5	2.1	2.2	6.4	7.1	7.2					

K522 HSS-E

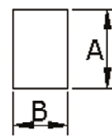
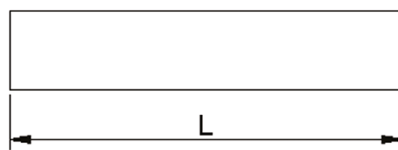

A	B	L	K522
10	3	200	K52210.0X3.0X200.0
12	3	200	K52212.0X3.0X200.0
10	4	200	K52210.0X4.0X200.0
16	4	200	K52216.0X4.0X200.0
20	4	200	K52220.0X4.0X200.0
18	5	200	K52218.0X5.0X200.0
20	5	200	K52220.0X5.0X200.0
10	6	200	K52210.0X6.0X200.0
12	6	200	K52212.0X6.0X200.0
16	6	200	K52216.0X6.0X200.0
20	6	200	K52220.0X6.0X200.0
25	6	200	K52225.0X6.0X200.0
12	8	200	K52212.0X8.0X200.0
16	8	200	K52216.0X8.0X200.0
20	8	200	K52220.0X8.0X200.0
12	10	200	K52212.0X10.0X200.0
16	10	200	K52216.0X10.0X200.0
20	10	200	K52220.0X10.0X200.0
25	12	200	K52225.0X12.0X200.0
25	16	200	K52225.0X16.0X200.0

M150

- Bussole di riduzione coniche e resistenti all'olio
- Reduzierhülsen, ölgehärtet und geschliffen
- Reduceerhuls, oliegehard
- Cône de réduction trempé

K=Ext. K1=Int.

K= äußerer MK, K1= innerer MK

K= uitw. K1= inw.

K=Ext.(externe) K1=Int. (Interne)



M150



Nr.	K = Nr.	K1 = Nr.	M150
10	1	0	M1501-0
21	2	1	M1502-1
31	3	1	M1503-1
41	4	1	M1504-1
32	3	2	M1503-2
42	4	2	M1504-2
52	5	2	M1505-2
43	4	3	M1504-3
53	5	3	M1505-3
54	5	4	M1505-4
65	6	5	M1506-5

M151

- Bussole di riduzione coniche, temprate e rettificate
- Reduzierhülsen, gehärtet und geschliffen
- Reduceerhuls, gehard en geslepen
- Cône de réduction

K=Ext. K1=Int.

K= äußerer MK, K1= innerer MK

K= uitw. K1= inw.

K=Ext.(externe) K1=Int. (Interne)



Nr.	K = Nr.	K1 = Nr.	M151
10	1	0	M1511-0
21	2	1	M1512-1
31	3	1	M1513-1
41	4	1	M1514-1
32	3	2	M1513-2
42	4	2	M1514-2
52	5	2	M1515-2
43	4	3	M1514-3
53	5	3	M1515-3
54	5	4	M1515-4
65	6	5	M1516-5

M152

- Estrattore di coni morse
- Austreibkeil
- Uitdrijfspie
- Extracteur d'outils



M152



Nr.	M152
0	M1520
1 + 2	M15212
3 + 4	M15234
4 + 5	M15245
6	M1526

M200

- Olio intero da taglio
- Hochleistungs-Schneidöl
- Snijolie
- Huile de coupe



A		M200
1/4 Ltr. 12x	1BLUE	M2000.25NR.1BLUE
1/4 Ltr. 12x	2RED	M2000.25NR.2RED
1/4 Ltr. 12x	3GREEN	M2000.25NR.3GREEN
1 Ltr.	1BLUE	M2001.0NR.1BLUE
1 Ltr.	2RED	M2001.0NR.2RED
1 Ltr.	3GREEN	M2001.0NR.3GREEN
5 Ltr.	1BLUE	M2005.0NR.1BLUE
5 Ltr.	2RED	M2005.0NR.2RED
5 Ltr.	3GREEN	M2005.0NR.3GREEN
20 Ltr.	1BLUE	M20020.0NR.1BLUE

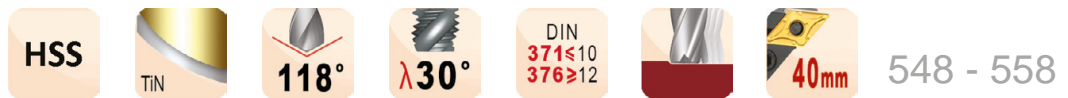

548 - 558

Informazioni Generali - Italiano 559 - 578

Allgemeine Informationen - Deutsch 579 - 598

Algemene informatie - Nederlands 599 - 618

Informations Générales - Français 619 - 638

547 - 640



Icone in comune / Allgemeine Symbole
Algemene symbolen / Symboles standards

Materiale
Material
Materiaal
Matière



Metallo duro
Hartmetall
Hardmetaal
Carbure



Acciaio super-rapido
Hochleistungsschnellarbeitsstahl
Snelstaal
Acier rapide



Acciaio super-rapido al cobalto
Hochlegierter Schnellarbeitsstahl
Cobalt gelegeerd snelstaal
Acier rapide au cobalt



Acciaio Sinterizzato al Cobalto
HSS-E-Pulvermetallurgisch
Cobalt gelegeerd "poedermetallurgisch" snelstaal
Acier rapide au cobalt fritté



Acciaio HSS-Metallo duro saldobrasato
Hochleistungsschnellarbeitsstahl/ Hartmetall
Snelstaal/ Hardmetaal
Acier rapide/ Carbure

Tratt.superficiali
Oberfläche
Oppervlak
Revêtement



Nitruro di Alluminio e Cromo
Aluminium-Chromnitrid
Alumium Chrom Nitride
Nitrure d'aluminium de chrome



Finitura Extra Lucida
Poliert
Gepolijst
Poli



Nitruro di Titanio e Silicio
Titan-Siliziumnitrid
Titanium Silicium Nitride
Nitrure de titane silicone



Senza trattamento / Steam Tempering
Dampfangelassen
Stoomontlaten
Traitement vapeur



Senza trattamento
Blank
Blank
Brillant



Bronzeo
Bronzefarben
Bronskleurig
Bronze



Diamante
Diamant- Beschichtung
Diamant gecoat
Diamant



Cromatura
Hartverchromt
Hardverchromd
Chrome dur



Super B



Nitruro di titanio e alluminio
Titanaluminiumnitrid-Beschichtung
Titanium-aluminium-nitride
Nitrure de titane aluminium



Carbo-nitruro di titanio
Titanicarbonitrid- Beschichtung
Titanium-carbonitride
Carbonitride de titane



Nitruro di titanio
Titanitrid-Beschichtung
Titanium-nitride
Nitrure de titane



Senza trattamento / Steam Tempering
Blank/Dampfangelassen
Blank/Stoomontlaten
Brillant/traitement vapeur



Senza trattamento/Nitruro di titanio
Blank/Titanitrid-Beschichtung
Blank/Titaniumnitride
Brillant/Nitrure de titane



Steam Tempering / Bronzeo
Dampfangelassen / Bronzefarben
Stoomontlaten / Bronskleurig
Traitement vapeur / Bronze



Nitruro di alluminio e titanio - Top
Titanaluminiumnitrid-Beschichtung - Top
Titanium-aluminium-nitride - Top
Nitrure de titane aluminium - Top



X-CEED



Ti-phon



Carbo-nitruro di alluminio e titanio
Aluminiumtitanicarbonitrid-Beschichtung
Aluminium-Titanium-carbonitride
Carbonitride d'aluminium titane



Nitruro di alluminio e titanio
Aluminiumtitanitrid-Beschichtung
Aluminium-Titanium-nitride
Nitrure d'aluminium titane



Alcrona



Alcrona Top



Alcrona Pro

Legenda Icone / Symbolerklärung
Verklaring symbolen / Description des symboles

Icone in comune / Allgemeine Symbole
Algemene symbolen / Symboles standard

Senso di rotazione Richtung Draairichting Direction		
	Destra Rechts Rechts À droite	Sinistra Links Links À gauche

Prestazioni Eignung Geschiktheid Appréciations		
	Raccomandata Sehr gut Uitstekend Excellent	Accettabile Gut Acceptabel Acceptable

Profondità Tiefe Diepte Profondeur									

Icone Foratura / Symbole Bohrwerkzeuge
Boor symbolen / Symboles pour le perçage









Angolo al vertice Spitzenwinkel Punthoek ° d'affûtage								
--	--	--	--	--	--	--	--	--

° di svasatura Senkwinkel Verzinkhoek ° d'épaulement				
	Punte a centrare a 60° Zentrierbohrer 60° Verzinkhoek 60° Chanfrein 60°	Punte a centrare con raggio Zentrierbohrer mit Radius Verzinkboor met radius Chanfrein à rayon	Punte a gradino a 90° eliche indipendenti Mehrfasen-Stufenbohrer 90° Meerfasen trapporen 90° Angle d'épaulement à 90°	Punte a gradino a 180° eliche indipendenti Mehrfasen-Stufenbohrer 180° Meerfasen trapporen 180° Angle d'épaulement à 180°
	Punte a gradino 90° Stufenbohrer 90° Trapporen 90° Forets étagés 90°	Punte a gradino 180° Stufenbohrer 180° Trapporen 180° Forets étagés 180°		

Forma Form Uitvoering Forme				
				Nucleo ad assottigliamento continuo Durchgehende Kernausspitzung Permanent uitgedunde kern Ame totalement amincie

Lubrificazione Kühlung Koeling Lubrification	
	Passaggio di Lubrorefrigerante Innere Kühlmittelzuführung Inwendig koelkanaal Lubrification interne

Icone Foratura / Symbole Bohrwerkzeuge
Boor symbolen / Symboles pour le perçage

Codolo Schaft Schacht Queue			
	Codolo cilindrico Zylinderschaft Cilindrisch Queue cylindrique	Codolo conico Morse Morsekegelschaft Morseconus Queue cône morse	DIN 6535 HA
			
	DIN 6535 HE DIN 6535 HE DIN 6535 HE DIN 6535 HE	Codolo con tenone Schaft mit Mitnehmerlappen Schacht met meeneemlip Queue avec tenon	Codolo con quadro Schaft mit Vierkant Schacht met vierkant Queue avec carré
			
	Codolo ridotto Reduzierter Schaft Verjongde schacht Queue réduite	DIN 6535 HB DIN 6535 HE DIN 6535 HB / HE Weldon of Whistle notch schacht	

Normativa
Standard
Norm
Standard

NAS 907	DIN 333A	DIN 333R	DIN 338	DIN 340	DIN 341	DIN 345	DIN 1869/1	DIN 1869/2	DIN 1869/3	DIN 1870/1
DIN 1870/2	DIN 1897	DIN 1899	DIN 6537 K	DIN 6537 L	DIN 6539	DIN 8037	DIN 8374	DIN 8376	DIN 8377	DIN ANSI
BS 328										

Legenda Icone / Symbolerklärung
 Verklaring symbolen / Description des symboles

Icone Alesatori - Svasatori / Symbole für Reibahlen und Kegelsenker
 Brotsjing - Verzinkers symbol / Symboles pour les alesages et les fraises coniques

Gradi di conicità al tagliente Kegelwinkel Coniciteit Conicité		
--	--	--

Tolleranza Toleranz Tolerantie Tolérance			
---	--	--	--

















Applicazione Anwendung Toepassing Utilisation	 Svasatore Kegelsenker Verzinkboren Fraises à chanfreiner	 Lamatore Flachsenken Kopverzinkboren Fraises pour logement de tête de vis	 G314	 M138
--	---	--	----------	----------

° di svasatura Senkwinkel Verzinkhoek Escareador ° d'épaulement	 60°	 82°	 90°	 100°
			 180° G314	 20° M138



Codolo Schaft Schacht Queue	 Codolo cilindrico Zylinderschaft Cilindrisch Queue cylindrique	 Codolo conico Morse Morsekegelschaft Morseconus Queue cône morse
--------------------------------------	---	---

Normativa Standard Standaard Standard											

Icone Filettatura / Symbole Gewindewerkzeuge
Schroefdraad symbolen / Symboles pour le taraudage

<p>Forma Filettatura Gewindeform Draadsoort Forme de filet</p>	 <p>M</p> <p>Filettatura metrica ISO grossa Metrisch Metrisch Métrique</p>	 <p>MF</p> <p>Filettatura metrica ISO fine Metrisch fein Metrisch fijn Métrique fin</p>	 <p>UNC</p> <p>Filettatura unificata ISO grossa Amerikanisches Einheits-Grobgewinde Amerikaanse draad grof Filetage américain</p>	 <p>UNF</p> <p>Filettatura unificata ISO fine Amerikanisches Einheits-Feingewinde Amerikaanse draad fijn Filetage américain pas fin</p>
	 <p>UN</p> <p>Filettatura unificata Einheitsgewinde für besondere Zwecke Amerikaanse draad Filetage américain</p>	 <p>G</p> <p>Filettatura cilindrica whitworth per tubi Rohrgewinde Gasdraad Filetage Gaz</p>	 <p>NPT</p> <p>Filettatura conica americana per tubi Amerikanisches Standard-Rohrgewinde kegelig Conische gasdraad Filetage Gaz conique</p>	 <p>NPTF</p> <p>Filettatura conica americana per tubi "dryseal" Amerikanisches kegelliges Feinrohrgewinde Whitworth Fijn Filetage NPTF</p>
	 <p>NPSF</p> <p>Filettatura cilindrica americana per tubi "dryseal" Zylindrisches Rohringewinde Rechte Amerikaanese gasdraad Filetage NPSF</p>	 <p>NPSM</p> <p>Filettatura cilindrica americana per tubi Zylindrisches Rohrgewinde Rechte Amerikaanese gasdraad Filetage NPSM</p>	 <p>BA</p> <p>Filettatura British Association British Association Standard-Gewinde Draad volgens Britse Norm Filetage BA</p>	 <p>BSF</p> <p>Filettatura British Standard Fine British Standard-Feingewinde Whitworth Fijn Withworth pas fin</p>
	 <p>BSW</p> <p>Filettatura Whitworth Grossa British Standard Whitworth-Grobgewinde Whitworth Grof Withworth</p>	 <p>EGM</p> <p>Filettatura metrica ISO grossa per inserti Einsatzgewinde metrisch Inzet schroefdraad Pour filets rapportés</p>	 <p>PG</p> <p>Filettatura per tubi corazzati Panzerrohrgewinde Pantserdraad Pour tubes électriques</p>	 <p>Rc</p> <p>Filettatura Conica Whitworth per Tubi Konisches Whitworth-Gewinde für Rohre Conische gasdraad Gaz conique Withworth</p>

<p>Geometria Geometrie Geometrie Géométrie</p>	 <p>Scanalature diritte Geradegenutet Rechte spaangroeven Goujures droites</p>	 <p>Scanalature diritte, imbocco corretto Geradegenutet mit Schälanschnitt Rechte groeven met schilaansnijding Coupe gun</p>	 <p>a rullare Gewindeformer Rolltappen A reouler</p>	 <p>a rullare, Canali di lubrificazione Gewindeformer, Ölnoten / Schmiernoten Rolltappen met smeergroeven A reouler, rainures de lubrification</p>
	 <p>λ 10°</p> <p>Scanalature elicoidali 10° Spiralgenutet 10° Gespiraliseerde spaangroeven 10° Goujures hélicoïdales 10°</p>	 <p>λ 15°</p> <p>15°</p>	 <p>λ 27°</p> <p>27°</p>	 <p>λ 30°</p> <p>30°</p>
	 <p>λ 35°</p> <p>35°</p>	 <p>λ 40°</p> <p>40°</p>	 <p>λ 45°</p> <p>45°</p>	 <p>λ 48°</p> <p>48°</p>

<p>Tipo di foro Art der Bohrung Type gat Type de trou</p>	 <p>Foro passante Durchgangsbohrung Doorlopend gat Trou débouchant</p>	 <p>Foro cieco Grundbohrung Blind gat Trou borgne</p>	 <p>Foro passante/cieco Durchgangs- oder Grundbohrung Doorlopend of blind gat Trou débouchant/borgne</p>
---	---	--	---

Legenda Icone / Symbolerklärung
Verklaring symbolen / Description des symboles

Icone Filettatura / Symbole Gewindewerkzeuge
Schroefdraad symbolen / Symboles pour le taraudage

Lunghezza Imbocco Anschnitt Aansnijding Chanfrein	B 3.5-5	C 2-3	C 2-3.5	E 1.5-2
Forma Imbocco B Anschnitt Form B Aansnijding vorm B Chanfrein No. B 3.5 - 5 X p	A 6-8 C 2-3	D18-20 C 2-3	1.75XP	2.25XP

Tolleranza Toleranz Tolerantie Tolérance	2A	2B	6G	6GX	6g	6H	6HX	Class A
---	-----------	-----------	-----------	------------	-----------	-----------	------------	----------------

Medium

Medio
Mittel
Middel
Moyen

Normal

Normale
Normal
Normaal
Normal

Codolo Schaft Schacht Queue	DIN 6535HA 	DIN 6535HB
--------------------------------------	--------------------------	--------------------------

Normativa Standard Norm Standard	DORMER DIN	DORMER ISO	DORMER ANSI	DIN 351	DIN 352	DIN 357	DIN 371	DIN 374	DIN 376	DIN 371≤10 376≥12	DIN 382
	DIN 2174	DIN 2181	DIN 2184-1	ISO 2283	ISO 2284	DIN 5156	DIN 5157	DIN 40432	DIN-EN 22568	ISO 529	ISO 2568
	ANSI	ANSI B94.9	BS 1127: 1950								

Icone Fresatura / Symbole Fräswerkzeuge
Frees symbolen / Symboles pour le fraisage

Tipo Typ Type Type	FS	HRA	N
	Rompitrucciolo per semi-finitura Schlichtfräser mit Spanbrecher Fijnruwvertanding Semi-finition Ebauche	Rompitrucciolo a profilo arrotondato asimmetrico a passo fine Asymetrische feine Schruppkordel-Verzahnung Fijnruwvertanding met asymmetrisch rond profiel Brise-copeaux ronds fins asymétrique	Tipo di elica per acciai da bassa ad alta resistenza Schlichtfräser Voor staal, lage tot hoge treksterkte Pour aciers de moyenne à haute résistance
	NF	NRA	W
	Rompitrucciolo a profilo piatto a passo grosso Schruppschlicht-Verzahnung Ruwvertanding met afgeplat rond profiel Brise-copeaux plats	Rompitrucciolo a profilo arrotondato asimmetrico a passo grosso Asymetrische Schruppkordel-Verzahnung Ruwvertanding met asymmetrisch rond profiel Brise copeaux ronds asymétrique	Tipo di elica per materiali duttili e malleabili Für weiche und langspanende Materialien Frezen voor zachte en smeedbare materialen Fraise pour les matières douces et malléables
	NR		
	Rompitrucciolo a profilo arrotondato a passo grosso Schruppkordel-Verzahnung Ruwvertanding met rond profiel Brise-copeaux ronds fins	Passo largo Grobe Zahnteilung Grove vertanding	Passo stretto Feine Zahnteilung Fijne vertanding

Applicazione Anwendung Toepassing Utilisation	P9			
	Fresa per cave tolleranza P9 Langlochfräsen in P9 Toleranz Spiebaanfrezen P9 Rainurage P9	Fresa per cave Langlochfräsen Spiebaanfrezen Rainurage	Super-Finitura Schlichtfräsen Glad nafrezen Super finition	Fresa per finitura Schlichten Nafrezen Finition
	Sgrossatura Schrupfräsen Voorfrezen Ébauche	Fresa semisferica Kopierfräsen Kopierfrezen Bout hémisphérique	Frese raggate mit Eckenradius Frezen met hoekradius A matrice torique	Alta velocità Hochvorschubfräsen (HFC) Hoge voeding frezen Grandes avance de Finition
	Frese per smussi Fasenfräsen Verzinkfrezen A chanfreiner	Fresa per scanalature a T T-Nutenfräsen T-gleuffrezen Pour rainures en T	Fresa per cave Woodruff Schlitzfräser für Scheibenfeder-Nuten Schijfspie-frezen Fraises Woodruff	Fresa a coda di rondine - divergente Winkelfräsen Zwaluwstaartfrezen Fraises coniques cône renversé
	Fresa a coda di rondine - convergente Winkelfräsen Duivenstaartfrezen Fraises coniques cône direct	Fresa a Raggio Concava Viertelrund-Profilfräser konkav Kwartholfrezen conkaaf Fraises concaves 1/4 de cercle	Fresa a disco Schlitzfräser/Sägeblätter Sleuffrezen/Zaagbladen Fraise 3 tailles	Multi Meersnijder
	Fresa a manicotto Walzenstirnfräsen Mantelkopfrezen Fraise 2 tailles finition	Sgrossatura Schruppen ruw ébauche		

Icone Fresatura / Symbole Fräswerkzeuge
Frees symbolen / Symboles pour le fraisage

Direzione Richtung Richtung Direction				
	Contornatura, in rampa e a tuffo. Kontourfräsen, Schrägeintauchen, Tauchen, Spiebaan-, insteek-, boren- en contourfrezzen Rainurage, ramping, plongée	Contornatura e in rampa. Kontourfräsen, Schrägeintauchen Helling- en contourfrezzen	Contornatura Kontourfräsen Contourfrezzen	Spianatura Kontourfräsen Contourfrezzen
	Rainurage, ramping, plongée	Rainurage, ramping	Finition	Fraisage

Lung. di taglio Schneidenlänge Snijkants lengte Longueur de coupe												
	Extra corta Extra kurz Extra kort Extra court				Media Mittel Middel Moyen				Extra lunga Extra lang Extra lang Extra Long			

Tolleranza diametro Schneiden-toleranz Tolerantie Tolérance	d11	e8	h9	h10	h11	h12	k10	k12	js14	js16
--	------------	-----------	-----------	------------	------------	------------	------------	------------	-------------	-------------



tolleranza e8 per diametri pieni e mezzi, h10 per gli altri
e8 für volle und halbe Durchmesser ansonsten h10
e8 voor hele en halve diameter, verder h10
e8 cotes rondes et intermédiaires, h10 autres

Angolo d'Elica/ Angolo di spoglia frontale Drallwinkel / Spanwinkel Hellingshoek / Spaanhoek Angle d'hélice / Angle de coupe	$\gamma 5^\circ$	$\gamma 15^\circ$	$\gamma 18^\circ$	$\lambda 0^\circ$ $\gamma 0^\circ$	$\lambda \neq$ $\gamma 10^\circ$	$\lambda 10^\circ$ $\gamma 10^\circ$	$\lambda 12^\circ$ $\gamma 10^\circ$	$\lambda 15^\circ$ $\gamma 10^\circ$	$\lambda 15^\circ$ $\gamma 15^\circ$	$\lambda 25^\circ$ $\gamma 0^\circ$	$\lambda 25^\circ$ $\gamma 20^\circ$
	$\lambda 30^\circ$ $\gamma -10^\circ$	$\lambda 30^\circ$ $\gamma 3^\circ$	$\lambda 30^\circ$ $\gamma 9^\circ$	$\lambda 30^\circ$ $\gamma 10^\circ$	$\lambda 30^\circ$ $\gamma 12^\circ$	$\lambda 30^\circ$ $\gamma 15^\circ$	$\lambda 30^\circ$ $\gamma 20^\circ$	$\lambda 35^\circ$ $\gamma 9^\circ$	$\lambda 35^\circ$ $\gamma 12^\circ$	$\lambda 40^\circ$ $\gamma -6^\circ$	$\lambda 40^\circ$ $\gamma 3^\circ$
	$\lambda 40^\circ$ $\gamma 4^\circ$	$\lambda 40^\circ$ $\gamma 10^\circ$	$\lambda 40^\circ$ $\gamma 15^\circ$	$\lambda 40^\circ$ $\gamma 20^\circ$	$\lambda 40^\circ$ $\gamma 25^\circ$	$\lambda 45^\circ$ $\gamma -10^\circ$	$\lambda 45^\circ$ $\gamma 12^\circ$	$\lambda 50^\circ$ $\gamma -26^\circ$	$\lambda 50^\circ$ $\gamma 3^\circ$		

N° Taglienti Zähneanzahl aantal tanden Dent	Z 1	Z 2	Z 3	Z 3-4	Z 3-5	Z 3-6	Z 4	Z 4-6	Z 4-8	Z 6-8	Z 6-10
	Z 6-12	Z 8-12	Z 10-12	Z 16-30	Z 28-44	Z 28-100	Z 40-200	Z 80-180	Z 100-140	Z 128-220	Z 160-350



4 taglienti - Spazio tra i taglienti differenziato
4 Zähne - ungleiche Teilung
4 tanden - Differentialiaal vertand
4 dents - pas inégal

Icone Filettatura / Symbole Fräswerkzeuge
Frees symbolen / Symboles pour le fraisage

Codolo Schaft Schacht Queue	<p>DIN 1835A</p>	<p>DIN 1835B</p>	<p>DIN1835 D B </p>	<p>DIN 1835D</p>
	<p>Cilindrico Form A, Glattschaft</p> <p>Glad cilindrisch</p>	<p>Form B, mit Mitnahmefläche (Weldon)</p> <p>Recht spanvlak, "Weldon"</p>	<p>Filettato/ Weldon Form D, mit Anzugsgewinde Form B, mit Mitnahmefläche (Weldon) Aantrekdraad/"Weldon"</p>	<p>Filettato Form D, mit Anzugsgewinde Aantrekdraad</p>
	<p>DIN 6535HA</p>	<p>DIN 6535HB</p>		
	<p>Cilindrico HA, Glattschaft Gladde eenheidsschacht</p>	<p>HB, Mitnahmefläche (Weldon) Eenheidsschacht met "Weldon"</p>		

Normativa Standard Norm Standard		<p>DIN 327D</p>	<p>DIN 844K</p>	<p>DIN 844L</p>	<p>DIN 850</p>	<p>DIN 851</p>	<p>DIN 885A</p>	<p>DIN 1833C</p>	<p>DIN 1833D</p>	<p>DIN 1837</p>	<p>DIN 1838</p>
		<p>DIN 1880</p>	<p>DIN 6527K</p>	<p>DIN 6527L</p>							

Icone sbavatore / Symbole Frässtift
Stiffrees symbolen / Symboles pour les Limes rotatives

Applicazione Anwendung Uitvoering Utilisation	A	B	C	D
	A	B	C	D
	cilindrico lavorazione sul lato Zylinder ohne Stirnverzahnung Cilindrisch zonder kopvertanding Cylindrique sans coupe en bout	cilindrico lavorazione lato e testa Zylinder mit Stirnverzahnung Cilindrisch met kopvertanding Cylindrique avec coupe en bout	cilindrico a testa sferica Walzenrund Ronde walsvorm Cylindrique à bout rond	a palla Kugel Kogelvorm Boule
	E	F	G	H
	ovale Tropfen Druppelvorm Ovale	ad albero a punta sferica Rundbogen Ronde boogvorm Ogive à bout rond	ad albero a punta Spitzbogen Spitze boogvorm Ogive à bout pointu	a fiamma Flamme Vlamvorm Vlamvorm
	J	K	L	M
	svasatore a 60°k 60° Kegelsenker 60° verzink kegelvorm Fraisure à 60°	svasatore a 90°k 90° Kegelsenker 90° verzink kegelvorm Fraisure à 90°	conico a palla Rundkegel Ronde kegelvorm Conique à bout rond	conico Spitzkegel Spitze kegelvorm Conique à bout rond
	N			
	conico invertito umgekehrter Kegel Omgekeerde kegelvorm Conique inverse	Lavorazione fibre di vetro Für faserverstärktes Material Router voor vezelversterkt materiaal Fraisage de la fibre de verre		

Tipo Typ Type Type	ST	VA	AL	GRP
	ST	VA	AL	GRP
	Generico	Acciaio inossidabile	Alluminio	Fibra di vetro
	Hohes Spanvolumen in Stählen	Hohes Spanvolumen in Edelmetallen	Alu-Verzahnung für NE-Metalle und Kunststoffe	Glasfaser und Verbundwerkstoffe
	Taux d'enlèvement élevé dans les aciers	Taux d'enlèvement élevé dans les aciers inoxydables	Coupe aluminium pour les matériaux non-ferreux et les plastiques	Fibre de verre et composites
	DC			
	Taglio doppio per lavorazioni generiche Kreuzverzahnung für allgemeine Anwendungen			
	Denture croisée pour utilisation générale			

tipi di taglio Stirngeometrie kopvertanding coupe en bout			
	1	2	3
	Lavorazione di testa Stirnverzahnung Standaard Standard	Forante e contornatura Bohrschneide Pointe de foret	Forante Schafffräser Fraise de finition

Icone Inserti di troncatura / Symbole für Abstechwerkzeuge
Wisselplatten symbol / Symboles pour les outils de tronçonnage

Inclinazione
tagliente
Abstechwinkel
Afsteekhoek
Angle de coupe



0°



8° sinistro / destro
8° links - rechts
8° Links - Rechts
8° à gauche - à droite



15° sinistro / destro
15° links - rechts
15° Links - Rechts
15° à gauche - à droite

Lunghezza
tagliente
Plattengröße
Grootte
Taille



23mm



40mm

Mano utensile
Abstechrichtung
Snijrichting
Direction de coupe



Destra
Rechts
Rechts
À droite



Sinistra
Links
Links
À gauche

Applicazione
Anwendung
Toepassing
Utilisation



Troncatura
Abstechen
Afsteken
Tronçonnage



Scanalatura
Einstecken
Ranhura
Gorge

Sezione
Drehlingsform
Form
Forme



Tonda
Rund
Rond
Rond



Quadrata
Vierkant
Vierkant
Carré



Rettangolare
Rechteckig
Rechthoekig
Rectangulaire

Tolleranza
Toleranz
Tolerantie
Tolérance



h9



h13

Normativa
Standard
Norm
Standard



Italiano		Durezza	Resistenza	ISO
Applicazione per Gruppi di Materiali		HB	N/mm ²	
1. Acciaio	1.1 Acciaio dolce magnetico	< 120	< 400	P 1
	1.2 Acciaio da costruzione e da cementazione	< 200	< 700	P 1
	1.3 Acciaio al carbonio	< 250	< 850	P 2
	1.4 Acciaio legato	< 250	< 850	P 3
	1.5 Acciaio legato / Acciaio bonificato e temprato	> 250 < 350	> 850 < 1200	P 4
	1.6 Acciaio legato / Acciaio bonificato e temprato	> 350	> 1200 < 1620	H 1
	1.7 Acciaio legato/temprato	49-55HRC	> 1620	H 3
	1.8 Acciaio legato/temprato	55-63HRC	> 1980	H 4
2. Acciaio inossidabile	2.1 Acciaio inossidabile/automatico	< 250	< 850	M 1
	2.2 Austenitico	< 320	< 1100	M 3
	2.3 Ferritico+Austenitico, Martensitico	< 300	< 1000	M 2
	2.4 Acciai inossidabili con indurimento da precipitazione	>320 <410	>1100 <1400	S 2
3. Ghisa	3.1 Ghisa con grafite lamellare	< 150	> 500	K 1
	3.2 Ghisa con grafite lamellare	> 150 <300	> 500 < 1000	K 2
	3.3 Ghisa malleabile con grafite sferoidale	< 200	< 700	K 3
	3.4 Ghisa malleabile con grafite sferoidale	> 200 < 300	> 700 < 1000	K 4
4. Titanio	4.1 Titanio non legato	< 200	< 700	S 1
	4.2 Leghe di titanio	< 270	< 900	S 2
	4.3 Leghe di titanio	> 270 < 350	> 900 ≤ 1250	S 3
5. Nichel	5.1 Nichel non legato	< 150	< 500	S 1
	5.2 Leghe di nichel	< 270	> 900	S 2
	5.3 Leghe di nichel	> 270 < 350	> 900 < 1200	S 3
6. Rame	6.1 Rame	< 100	< 350	N 3
	6.2 β-Ottone, Bronzo	< 200	< 700	N 4
	6.3 α-Ottone	< 200	< 700	N 3
	6.4 Bronzo ad alta resistenza	< 470	< 1500	N 4
7. Alluminio Magnesio	7.1 Al, Mg, non legato	< 100	< 350	N 1
	7.2 Leghe di Al, Si < 0.5%	< 150	< 500	N 1
	7.3 Leghe di Al, Si > 0.5% < 10%	< 120	< 400	N 1
	7.4 Leghe di Al, Si > 10% Rinforzate Whisker Leghe di Al, Leghe di Mg	< 120	< 400	N 2
8. Materiali sintetici	8.1 Materiali termoplastici	***	***	O
	8.2 Materiali plastici termoidurenti	***	***	O
	8.3 Materiali plastici rinforzati	***	***	O
9. Materiali duri	9.1 Cermets (materiali metallo-ceramici)	< 550	< 1700	H
	10. Grafite	***	< 100	O

ESEMPI DI MATERIALI CLASSIFICATI
SECONDO STANDARD DIVERSI

AMS	EN	W.Nr.	DIN	BS	SS	USA	UNS	ISO
1.1		1.1015, 1.1013	Rle60, Rle100	230M07, 050A12	1160	Lead Steels	G12120	P 1
1.2	EN 10 025 - S235JR2	1.1012, 1.1053, 1.7131	S137-2, 16MnCr5, S150-2	060A35, 080M40, 4360-50B	1312, 1412, 1914	135, 30	G10100	P 1
1.3	EN 10 025 - E295	1.1191, 1.0601	CK45, C60	080M46, 080A62	1550, 2142, 2172	1024, 1060, 1061	G10600	P 2
1.4	EN 10 083-1 - 42 CrMo 4 - EN 10 270-2	1.7225, 1.3505, 1.6582, 1.3247	42CrMo4, 100Cr6, 34CrNiMo6, S2-10-1-8	708M40/42, 817M40, 534A99, BM2, BT42	1672-04, 2090, 2244-02, 2541-02	4140, A2, 4340, M42, M2	G41270, G41470, T30102, T11342	P 3
1.5	EN ISO 4857 - H86-5-2 - EN ISO 4857 - H86-5-2.5	1.2510, 1.2713, 1.3247, 1.2080	100MnCrW12, 55NiCrMoV6, X210Cr12, S2-10-1-8	801, BM2, BT142, 826 M40, 830M31	2244-04, 2541-03, 2550, 2722, 2723	01, L6, M42, D3, A2, M2, 4140, 8630	G96300, T30102, T11302, T30403, T11342	P 4
1.6	EN ISO 4857 - HS2-9-1-8	1.2510, 1.2713, 1.3247, 1.2080	100MnCrW12, X210Cr12, S2-10-1-8	801, 826 M40, 830M31	2244-05, 2541-05, , HARDOX 400	01, L6, M42, D3, 4140, 8130	T30403, G41400, J14047	H 1
1.7	EN ISO 4857 - HS2-9-1-8	1.2510	100MnCrW4	BO1, BD3, BH13	HARDOX 500			H 3
1.8	EN ISO 4857 - X40CrMoV5-1	1.3343, 1.2344	S6-5-2, GX40CrMoV5-1	BM2, BH13	2242, HARDOX 600			H 4
2.1	EN 10 088-3 - X14CrMoS17	1.4305, 1.4104	X10CrNiSi189, X12CrMoS17	303 S21, 416 S37	2301, 2312, 2314, 2346, 2380	303, 416, 430F	S30300, S41600, S43020	M 1
2.2	EN 10 088-2-0 - 3 - 1, 4301+AT	1.4301, 1.4541, 1.4571	X5CrNi189, X10CrNiMoTi1810	304 S15, 321 S17, 316 S, 320 S12	2310, 2333, 2337, 2343, 2353, 2377	304, 321, 316	S30400, S32100, S31600	M 3
2.3	EN 10 088-3 - 1, 4460	1.4460, 1.4512, 1.4582	X8CrNiMo275, X4CrNiMoNi6257	317 S16, 316 S16	2324, 2387, 2570	409, 430, 436	S40900, S4300, S43600	M 2
2.4	EN 1,4547	1.4547	X2CrNiMo20-18-6	HR41	2378	17-4PH	S31254	S 2
3.1	EN 1561 - EN-JL1030	0.6010, 0.6040	GG10, GG40	Grade150, Grade 400	0120, 0212, 0814	ASTM A48 class 20	F11401, F12801	K 1
3.2	EN 1561 - EN-JL1050	0.6025, 0.6040	GG25, GG40	Grade200, Grade 400	0125, 0130, 0140, 0217	ASTM A48 class 40, STM A48 class 60	F12801, F14101	K 2
3.3	EN 1561 - EN-JL2040	0.7040, 0.7070, 0.8145, 0.8045	GGG40, GGG70, GTS45-06, GTW45-07	420/12, P4407, 700/2, 309/72	0219, 0717, 0727, 0732, 0852	ASTM A220 grade 40010, ASTM A602 grade M4504	F22830, F20001	K 3
3.4	EN 1561 - EN-JL2050	0.7040, 0.7070, 0.8145, 0.8045	GGG40, GGG70, GTS45-06, GTW45-07	420/12, P4407, 700/2, 309/72	0221, 0223, 0737, 0854	ASTM A220 grade 90001, ASTM A602 grade M8501	F26230, 20005	K 4
4.1		3,7024LN	T199,8	TA1 to 9	T199,8	ASTM B265 grade 1	R50250	S 1
4.2		3,7164LN, 3,7119LN	TA16V4, TA165n2	TA10 to 14, TA17	TA16V4, TA165n2	AMS4928	R54790	S 2
4.3		3,7164LN, 3,7174LN, 3,7184LN	TA16V4, TA16V5Sn2, TA14MoSn2	TA10 to 13, TA28	TA16V5Sn2	AMS4928, AMS4971	R56400, R54790	S 3
5.1		2,4060, 2,4066	Nickel 200, 270, N199,6	NA 11, NA12	NI200, NI270	Nickel 200, Nickel 230	N02200, N02230	S 1
5.2		2,4630LN, 2,4602, 2,4650LN	Nimonic 75, Monel 400, Hastelloy C, Inconel 600	HR203, 3027-76		Nimonic 75, Monel 400, Hastelloy, Inconel600	N06075, N10002, N04400, N06600	S 2
5.3		2,4668LN, 2,4631LN, 2,6554LN	Inconel 718, Nimonic 80A, Waspaloy	HR8, HR401, 601		Inconel 718, 625, Nimonic 80	N07718, N07080, N06625	S 3
6.1	EN 1652 - CW004A	2,0060, 2,0070	E-Cu57, SE-Cu	C101	5010	101	C10100, C1020	N 3
6.2	EN 1652 - CW612N	2,0380, 2,0360, 2,1030, 2,1080	CuZn39Pb2, CuZn40, CuSn8, CuSn6Zn	CZ120, CZ109, PB104	5168		C28000, C37710	N 4
6.3	EN 1652 - CW508L	2,0321, 2,0260	CuZn37, CuZn28	CZ108, CZ106	5150		C2600, C27200	N 3
6.4			Ampco 18, Ampco 25	AB1 type	5238, JM7-20			N 4
7.1	EN 485-2 - EN AW-1070A	3,0255	A199,5	LMO, 1 B (1050A)	4005	EC, 1060, 1100	A91060, A91100	N 1
7.2	EN 755-2 - EN AW-5005	3,1355, 3,3525	AlCuMg2, AlMg2Mn0,8	LM5, 10, 12, N4 (5251)	4106, 4212	380, 520,0, 520,2, 2024, 6061	A03800, A05200, A92024	N 1
7.3	EN 1706 - EN AC-42000	3,2162,05, 3,2341,01	GD-ALSi8Cu, G-ALSi5Mg	LM2,4,16,18,21,22,, 24,25,26,27,L109	4244	319,0, 333,0, 319,1, 356,0	A03190, A03330, C35600	N 1
7.4	SS-EN 1706 - EN AC-47000	3,2581,01	G-ALSi18, G-ALSi12	LM6, 12,13, 20, 28, 29, 30	4260, 4261, 4262	4032, 222,1, A332,0	A94032, A02220, A13320	N 2
8.1		8,1	Polystyrene, Nylon, PVC Cellulose, Acetate & Nitrate			Polystyrene, Nylon, PVC		O
8.2			Ebonite, Tufnol, Bakelite			Bakelite		O
8.3			Kevlar, Pinned Circuit boards			Kevlar		O
9.1		9,1	Ferroc, Ferroclitanti					H
10.1			Graphite					O

Tabella delle velocità di taglio



Vc (Velocità di taglio)																	
m/min	5	8	10	15	20	25	30	40	50	60	70	80	90	100	110	150	
Feet/Min	16	26	32	50	66	82	98	130	165	197	230	262	296	330	362	495	
Ø		Giri/minuto (RPM)															
mm	inch																
1,00		1592	2546	3183	4775	6366	7958	9549	12732	15916	19099	22282	25465	28648	31831	35014	47747
1,50		1061	1698	2122	3183	4244	5305	6366	8488	10610	12732	14854	16977	19099	21221	23343	31831
2,00		796	1273	1592	2387	3183	3979	4775	6366	7958	9549	11141	12732	14324	15916	17507	23873
2,50		637	1019	1273	1910	2546	3183	3820	5093	6366	7639	8913	10186	11459	12732	14006	19099
3,00		531	849	1061	1592	2122	2653	3183	4244	5305	6366	7427	8488	9549	10610	11671	15916
3,18	1/8	500	801	1001	1501	2002	2502	3003	4004	5005	6006	7007	8008	9009	10010	11011	15015
3,50		455	728	909	1364	1819	2274	2728	3638	4547	5457	6366	7276	8185	9095	10004	13642
4,00		398	637	796	1194	1592	1989	2387	3183	3979	4775	5570	6366	7162	7958	8754	11937
4,50		354	566	707	1061	1415	1768	2122	2829	3537	4244	4951	5659	6366	7074	7781	10610
4,76	3/16	334	535	669	1003	1337	1672	2006	2675	3344	4012	4681	5350	6018	6687	7356	10031
5,00		318	509	637	955	1273	1592	1910	2546	3183	3820	4456	5093	5730	6366	7003	9549
6,00		265	424	531	796	1061	1326	1592	2122	2653	3183	3714	4244	4775	5305	5836	7958
6,35	1/4	251	401	501	752	1003	1253	1504	2005	2506	3008	3509	4010	4511	5013	5514	7519
7,00		227	364	455	682	909	1137	1364	1819	2274	2728	3183	3638	4093	4547	5002	6821
7,94	5/16	200	321	401	601	802	1002	1203	1604	2004	2405	2806	3207	3608	4009	4410	6013
8,00		199	318	398	597	796	995	1194	1592	1989	2387	2785	3183	3581	3979	4377	5968
9,00		177	283	354	531	707	884	1061	1415	1768	2122	2476	2829	3183	3537	3890	5305
9,53	3/8	167	267	334	501	668	835	1002	1336	1670	2004	2338	2672	3006	3340	3674	5010
10,00		159	255	318	477	637	796	955	1273	1592	1910	2228	2546	2865	3183	3501	4775
11,11	7/16	143	229	287	430	573	716	860	1146	1433	1719	2006	2292	2579	2865	3152	4298
12,00		133	212	265	398	531	663	796	1061	1326	1592	1857	2122	2387	2653	2918	3979
12,70	1/2	125	201	251	376	501	627	752	1003	1253	1504	1754	2005	2256	2506	2757	3760
14,00		114	182	227	341	455	568	682	909	1137	1364	1592	1819	2046	2274	2501	3410
14,29	9/16	111	178	223	334	446	557	668	891	1114	1337	1559	1782	2005	2228	2450	3341
15,00		106	170	212	318	424	531	637	849	1061	1273	1485	1698	1910	2122	2334	3183
15,88	5/8	100	160	200	301	401	501	601	802	1002	1203	1403	1604	1804	2004	2205	3007
16,00		99	159	199	298	398	497	597	796	995	1194	1393	1592	1790	1989	2188	2984
17,46	11/16	91	146	182	273	365	456	547	729	912	1094	1276	1458	1641	1823	2005	2735
18,00		88	141	177	265	354	442	531	707	884	1061	1238	1415	1592	1768	1945	2653
19,05	3/4	84	134	167	251	334	418	501	668	835	1003	1170	1337	1504	1671	1838	2506
20,00		80	127	159	239	318	398	477	637	796	955	1114	1273	1432	1592	1751	2387
24,00		66	106	133	199	265	332	398	531	663	796	928	1061	1194	1326	1459	1989
25,00		64	102	127	191	255	318	382	509	637	764	891	1019	1146	1273	1401	1910
27,00		59	94	118	177	236	295	354	472	589	707	825	943	1061	1179	1297	1768
30,00		53	85	106	159	212	265	318	424	531	637	743	849	955	1061	1167	1592
32,00		50	80	99	149	199	249	298	398	497	597	696	796	895	995	1094	1492
36,00		44	71	88	133	177	221	265	354	442	531	619	707	796	884	973	1326
40,00		40	64	80	119	159	199	239	318	398	477	557	637	716	796	875	1194
50,00		32	51	64	95	127	159	191	255	318	382	446	509	573	637	700	955

HV Vickers	HRC Rockwell	HB Brinell	N/ mm ²	Tons/ sq. in.
940	68			
900	67			
864	66			
829	65			
800	64			
773	63			
745	62			
720	61			
698	60			
675	59			
655	58		2200	142
650		618	2180	141
640		608	2145	139
639	57	607	2140	138
630		599	2105	136
620		589	2070	134
615	56	584	2050	133
610		580	2030	131
600		570	1995	129
596	55	567	1980	128
590		561	1955	126
580		551	1920	124
578	54	549	1910	124
570		542	1880	122
560	53	532	1845	119
550		523	1810	117
544	52	517	1790	116
540		513	1775	115
530		504	1740	113
527	51	501	1730	112
520		494	1700	110
514	50	488	1680	109
510		485	1665	108
500		475	1630	105
497	49	472	1620	105
490		466	1595	103
484	48	460	1570	102
480		456	1555	101
473	47	449	1530	99
470		447	1520	98
460		437	1485	96
458	46	435	1480	96
450		428	1455	94
446	45	424	1440	93
440		418	1420	92

HV Vickers	HRC Rockwell	HB Brinell	N/ mm ²	Tons/ sq. in.
434	44	413	1400	91
423	43	402	1360	88
413	42	393	1330	86
403	41	383	1300	84
392	40	372	1260	82
382	39	363	1230	80
373	38	354	1200	78
364	37	346	1170	76
355	36	337	1140	74
350		333	1125	73
345	35	328	1110	72
340		323	1095	71
336	34	319	1080	70
330		314	1060	69
327	33	311	1050	68
320		304	1030	67
317	32	301	1020	66
310	31	295	995	64
302	30	287	970	63
300		285	965	62
295		280	950	61
293	29	278	940	61
290		276	930	60
287	28	273	920	60
285		271	915	59
280	27	266	900	58
275		261	880	57
272	26	258	870	56
270		257	865	56
268	25	255	860	56
265		252	850	55
260	24	247	835	54
255	23	242	820	53
250	22	238	800	52
245		233	785	51
243	21	231	780	50
240		228	770	50
235		223	755	49
230		219	740	48
225		214	720	47
220		209	705	46
215		204	690	45
210		199	675	44
205		195	660	43
200		190	640	41

Tabella delle tolleranze



Toll	Ø mm							
	> 1 ≤ 3	> 3 ≤ 6	> 6 ≤ 10	> 10 ≤ 18	> 18 ≤ 30	> 30 ≤ 50	> 50 ≤ 80	> 80 ≤ 120
	µm							
e8	-14 / -28	-20 / -38	-25 / -47	-32 / -59	-40 / -73	-50 / -89	-60 / -106	-72 / -126
f6	-6 / -12	-10 / -18	-13 / -22	-16 / -27	-20 / -33	-25 / -41	-30 / -49	-36 / -58
f7	-6 / -16	-10 / -22	-13 / -28	-16 / -34	-20 / -41	-25 / -50	-30 / -60	-36 / -71
h6	0 / -6	0 / -8	0 / -9	0 / -11	0 / -13	0 / -16	0 / -19	0 / -22
h7	0 / -10	0 / -12	0 / -15	0 / -18	0 / -21	0 / -25	0 / -30	0 / -35
h8	0 / -14	0 / -18	0 / -22	0 / -27	0 / -33	0 / -39	0 / -46	0 / -54
h9	0 / -25	0 / -30	0 / -36	0 / -43	0 / -52	0 / -62	0 / -74	0 / -87
h10	0 / -40	0 / -48	0 / -58	0 / -70	0 / -84	0 / -100	0 / -120	0 / -140
h11	0 / -60	0 / -75	0 / -90	0 / -110	0 / -130	0 / -160	0 / -190	0 / -220
h12	0 / -100	0 / -120	0 / -150	0 / -180	0 / -210	0 / -250	0 / -300	0 / -350
k10	+40 / 0	+48 / 0	+58 / 0	+70 / 0	+84 / 0	+100 / 0	+120 / 0	+140 / 0
k12	+100 / 0	+120 / 0	+150 / 0	+180 / 0	+210 / 0	+250 / 0	+300 / 0	+350 / 0
m7	+2 / +12	+4 / +16	+6 / +21	+7 / +25	+8 / +29	+9 / +34	+11 / +41	+13 / +48
js14	+/- 125	+/- 150	+/- 180	+/- 215	+/- 260	+/- 310	+/- 370	+/- 435
js16	+/- 300	+/- 375	+/- 450	+/- 550	+/- 650	+/- 800	+/- 950	+/- 1100
H7	+10 / 0	+12 / 0	+15 / 0	+18 / 0	+21 / 0	+25 / 0	+30 / 0	+35 / 0
H8	+14 / 0	+18 / 0	+22 / 0	+27 / 0	+33 / 0	+39 / 0	+46 / 0	+54 / 0

1µm = 0.001mm

FORATURA

Informazioni Generali sulla Foratura

1. Selezionate la punta più idonea per l'applicazione, per il tipo di materiale da lavorare, le caratteristiche della macchina utensile ed il lubrificante da usare.
2. Troppo gioco tra il pezzo da lavorare ed il mandrino della macchina possono rovinare l'utensile, il pezzo stesso e la macchina – assicuratevi sempre che vi sia la massima stabilità, che, comunque, può essere migliorata selezionando la punta più corta in relazione al lavoro da eseguire.
3. La tenuta dell'utensile è un aspetto importante nelle operazioni di foratura e la punta non deve né ruotare né muoversi nel portautensili.
4. L'uso corretto di un codolo cono Morse dipende dal perfetto accoppiamento tra le superfici coniche dell'utensile ed il portautensili. E' consigliabile l'uso di un martello di materiale tenero per inserire la punta nel portautensili.
5. E' consigliabile l'uso di lubrificanti o lubrificanti in operazioni di foratura. Assicurarsi di un'emissione copiosa di lubrificante o lubrificante in particolare sul punto di foratura.
6. La rimozione del truciolo in fase di foratura è essenziale per garantire una lavorazione corretta. Non lasciare che i trucioli intasino le scanalature.
7. In fase di riaffilatura della punta, far sempre in modo che la geometria originale sia ripristinata e che tutti i segni di usura vengano eliminati.

TIPI DI PUNTE

Con il continuo progredire delle configurazioni geometriche, dei materiali di fabbricazione e dei rivestimenti aumenta la capacità di una punta di forare con diversi valori di tolleranza sul diametro. In generale, un utensile a geometria standard da origine ad un foro con tolleranza H12. Con l'aumento della complessità geometrica della punta il foro potrà raggiungere, in condizioni favorevoli, anche tolleranza H8.

- Punta in acciaio super-rapido per impieghi generali – H12
- Punta per foratura profonda in acciaio super-rapido /HSS-E a scanalatura parabolica (PFX) – H10
- Punta in metallo duro per alte prestazioni rivestite al TiN / TiALN (CDX) – H8/H9

FORATURA PROFONDA

Per operazioni di foratura profonda si possono usare vari metodi per ottenere la profondità richiesta. L'esempio sotto riportato mostra quattro diversi modi di forare con profondità di 10 x il diametro della punta.

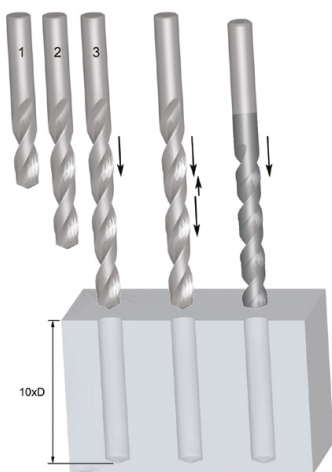

	Foratura in Serie	Foratura in Serie
Nr/ Di punte	3 (2,5xD, 6xD, 10xD)	2 (2,5xD, 10xD)
Tipo di punta	Geometria standard, impieghi generali	2.5xD ADX or PFX 10xD PFX
+ / -	Costoso Lungo	Più efficace, veloce

	Foratura ad utensile unico - con più estrazioni	Foratura ad utensile unico - senza estrazioni
Nr/ Di punte	1 (10xD)	1 (10xD)
Tipo di punta	Geometria standard, impieghi generali	Geometria PFX ed utensili per impieghi specifici
+ / -	Lungo	Efficace Veloce

RISOLUZIONE PROBLEMI DURANTE LA FORATURA

PROBLEMA	CAUSA	SOLUZIONE
Tenoni rotti o deformati	Cattiva tenuta tra codolo e portautensile	Verificare che codolo e portautensile siano puliti e esenti da danni.
Fessurazione del nucleo	Avanzamento troppo elevato	Ridurre avanzamento a valori ottimali
	Insufficiente spoglia iniziale	Riaffilare secondo specifiche
	Eccessivo assottigliamento del nucleo	Riaffilare secondo specifiche
	Grave urto al vertice dell'utensile	Evitare il fenomeno. Fare attenzione in fase di inserimento/estrazione nel/dal mandrino di punta a codolo conico
Spigoli di taglio consumati	Velocità eccessiva	Ridurre la velocità a valori ottimali - si potrebbe aumentare l'avanzamento
Spigoli di taglio esterni danneggiati	Cattivo assemblaggio	Ridurre il gioco fra i componenti
Taglienti scheggiati	Eccessivo gioco iniziale	Riaffilare secondo specifica
Rottura ad inizio scanalatura	Intasamento delle scanalature	Adottare concetto di foratura con scarichi intermedi
	Slittamento utensile nel mandrino	Assicurarsi che l'utensile sia fissato correttamente nel mandrino porta-punta
Traccia "a spirale" nel foro	Avanzamento insufficiente	Aumentare avanzamento
	Scarsa precisione nel posizionamento	Usare una punta da centro prima della foratura
Diametro foro eccessivamente largo	Geometria non corretta dell'utensile	Verificare la geometria di riaffilatura
	Rimozione truciolo insufficiente	Modificare velocità, avanzamento e numero di scarichi per consentire una migliore evacuazione del truciolo.

INFORMAZIONI GENERALI SULL' ALESATURA

Per ottenere i migliori risultati nell'utilizzo degli alesatori è necessario farli "lavorare".

E' un errore comune preparare i fori per l'alesatura con sovrametallo troppo scarso. Se il sovrametallo è insufficiente l'alesatore tenderà a comprimere il materiale piuttosto che tagliarlo, usurandosi velocemente con conseguente perdita di diametro. E' altrettanto importante non lasciare troppo sovrametallo nel foro di preparazione (Vedere Rimozione del Sovrametallo sotto riportata).

1. Selezionare l'alesatore, la velocità e l'avanzamento più consoni per l'operazione. Assicurarsi che i prefori abbiano il diametro corretto.
2. Il pezzo deve essere mantenuto rigido ed il mandrino non avere gioco.
3. Il mandrino che regge l'alesatore a codolo cilindrico deve essere di buona qualità. Se l'alesatore ruotasse nel mandrino e l'avanzamento fosse automatico, l'alesatore potrebbe arrivare a rottura.
4. Mantenere al minimo la lunghezza libera dell'utensile fuori dal mandrino della macchina.
5. Usare esclusivamente lubrificanti raccomandati per salvaguardare la vita dell'utensile e verificare che il fluido giunga nelle zone di taglio in modo corretto. Poichè l'alesatura non è un'operazione gravosa, l'impiego di una emulsione diluita 40: 1 è sufficiente. Per ghisa grigia, in operazioni a secco, si può impiegare anche un getto d'aria.
6. Le scanalature dell'alesatore non dovranno mai intasarsi di trucioli.
7. Prima della riaffilatura dell'alesatore verificare il valore di concentricità disponendo l'utensile fra i centri. In molti casi sarà sufficiente riaffilare solo lo smusso imbocco.
8. Gli alesatori devono essere sempre affilati. Una frequente riaffilatura è utile, ma è importante comprendere che gli alesatori tagliano solo sullo smusso e non sui taglienti cilindrici. Di conseguenza solo tali smussi richiedono la riaffilatura. L'accuratezza nell'operazione è indispensabile per salvaguardare la qualità dei fori e la vita dell'utensile.

RIMOZIONE DEL SOVRAMETALLO

Nelle operazioni di alesatura la quantità di sovrametallo da rimuovere dipende dal tipo di materiale e di finitura superficiale del pre-foro. Una guida per la rimozione del sovrametallo viene indicata nelle tabelle sotto riportate:

Misura del foro alesato (mm)	Con pre-foro	Con allargatore	Misura del foro alesato (pollici)	Con preforo	Con allargatore
Sotto 4	0.1	0.1	Sotto 3/16	0.004	0.004
Da 4 a 11	0.2	0.15	Da 3/16 a 1/2	0.008	0.006
Da 39 a 50	0.3	0.2	Da 1/2 a 1. 1/2	0.010	0.008
Da 39 a 50	0.4	0.3	Da 1.1/2 a 2	0.016	0.010

LIMITI DI TOLLERANZA



1. DIAMETRO DI TAGLIO DI ALESATORI STANDARD

Il diametro (d_1) è misurato sul diametro immediatamente prossimo allo smusso. la tolleranza è secondo DIN 1420 e dà origine a fori H7.

TOLLERANZA ALESATORE			
Diametro (mm)		Limite di tolleranza (mm)	
Oltre	Fino a incluso	Alta +	Bassa +
	3	0.008	0.004
3	6	0.010	0.005
6	10	0.012	0.006
10	18	0.015	0.008

TOLLERANZA ALESATORE			
Diametro (mm)		Limite di tolleranza (mm)	
Oltre	Fino a incluso	Alta +	Bassa +
18	30	0.017	0.009
30	50	0.021	0.012
50	80	0.025	0.014

2. FORO H7

La tolleranza più comune su un foro H7 (vedi tabella sotto). Per qualsiasi altra tolleranza usare il punto 3 per il calcolo del campo di tolleranza e la dimensione dell'alesatore.

TOLLERANZA FORO			
Diametro (mm)		Limite di tolleranza (mm)	
Oltre	Fino a incluso	Alta +	Bassa +
	3	0.010	0
3	6	0.012	0
6	10	0.015	0
10	18	0.018	0

TOLLERANZA FORO			
Diametro (mm)		Limite di tolleranza (mm)	
Oltre	Fino a incluso	Alta +	Bassa +
18	30	0.021	0
30	50	0.025	0
50	80	0.030	0

3. Quando necessario, definire le dimensioni di un alesatore speciale per operazioni di taglio secondo tolleranze specifiche, come ad esempio D8, si consiglia la consultazione di questo manuale.

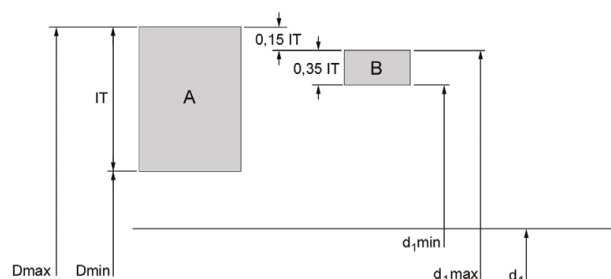

A = Tolleranza foro
 B = Tolleranza alesatore
 IT = Campo di tolleranza
 Dmax = Diametro max del foro
 Dmin = Diametro min del foro
 d_1 = Diametro nominale
 $d_{1,max}$ = Diametro max alesatore
 $d_{1,min}$ = Diametro min alesatore

Campo di tolleranza	Campo di tolleranza (μm) in relazione al diametro (mm)							
	da 1 fino a 3	da 3 fino a 6	da 6 fino a 10	da 10 fino a 18	da 18 fino a 30	da 30 fino a 50	da 50 fino a 80	da 80 fino a 120
IT5	4	5	6	8	9	11	13	15
IT6	6	8	9	11	13	16	19	22
IT7	10	12	15	18	21	25	30	35
IT8	14	18	22	27	33	39	46	54
IT9	25	30	36	43	52	62	74	87
IT10	40	48	58	70	84	100	120	140
IT11	60	75	90	110	130	160	190	220
IT12	100	120	150	180	210	250	300	350

Esempio di foro da 10mm con tolleranza D8, Diametro Massimo del Foro = 10.062, Diametro Minimo del Foro = 10.040

Il limite massimo per l'alesatore è il limite massimo della grandezza del foro ridotta di 0.15 volte la tolleranza del foro. Il valore è, poi, arrotondato al multiplo superiore di 0.001mm

$0.15 \times \text{tolleranza foro (IT8)} = 0.0033$, arrotondato = 0.004

Il limite minimo per l'alesatore è il limite massimo dell'alesatore stesso ridotto di 0.35 volte la tolleranza del foro. Il valore è, poi, arrotondato al multiplo superiore di 0.001mm.

$0.35 \times \text{tolleranza foro (IT8)} = 0.0077$, arrotondato = 0.008

Limite massimo per l'alesatore = $10.062 - 0.004 = 10.058$

Limite minimo per l'alesatore = $10.058 - 0.008 = 10.050$

RISOLUZIONE DEI PROBLEMI DURANTE L'ALESATURA

PROBLEMA	CAUSA	SOLUZIONE
tenoni rotti o deformati	Tenuta insufficiente tra codolo e bussola di presa	Verificare che codolo e bussola siano puliti ed esenti da danni
Rapida usura utensile	Insufficiente sovrametallo da rimuovere	Aumentare il quantitativo di sovrametallo da asportare
Foro sovradimensionato	Eccessiva variazione in altezza del tagliente	Riaffilare a specifica
	Il mandrino della macchina è instabile	Eseguire Rettifica mandrino
	Difetti del portautensile	Sostituire il portautensile
	Codolo dell'utensile danneggiato	Sostituire o riaffilare il codolo
	Ovalizzazione dell'utensile	Sostituire o riaffilare l'utensile
	Avanzamento o velocità di taglio troppo elevate	Riaffilare a specifica
	Avanzamento o velocità di taglio troppo elevate	Correggere i parametri di taglio secondo il catalogo o il Selector.
Foro sottodimensionato	Insufficiente sovrametallo da rimuovere	Aumentare il quantitativo di sovrametallo da asportare
	Eccessivo sviluppo di calore in fase d'alesatura. Il foro prima si dilata e poi si contrae.	Aumentare il flusso di refrigerante
	Il diametro dell'utensile è usurato e sotto misura.	Riaffilare a specifica.
	Avanzamento o velocità di taglio troppo basse	Correggere i parametri di taglio secondo il catalogo o il Selector
	Preforo troppo piccolo	Diminuire il quantitativo di sovrametallo da asportare
Fori ovali e conici	Il mandrino della macchina è instabile	Eseguire rettifica mandrino
	Disallineamento tra utensile e foro	Utilizzare un alesatore per chiodi
	Angolo di smusso asimmetrico	Riaffilare a specifica.
Cattiva finitura del foro	Eccessivo sovrametallo da rimuovere	Diminuire il quantitativo di sovrametallo da asportare
	Utensile danneggiato	Riaffilare a specifica.
	Angolo di taglio troppo piccolo	Riaffilare a specifica.
	Emulsione o olio da taglio troppo diluito	Aumentare % di concentrazione
	Avanzamento o velocità di taglio troppo basse	Correggere i parametri di taglio secondo il catalogo o il Selector
	Velocità di taglio troppo elevata	Correggere i parametri di taglio secondo il catalogo o il Selector
L'utensile si incolla e si rompe	Utensile danneggiato	Riaffilare a specifica.
	Rastrematura posteriore dell'utensile insufficiente	Verificare e sostituire/ modificare l'utensile
	La larghezza del bordino è eccessiva	Verificare e sostituire/ modificare l'utensile
	Il materiale tende a comprimersi	Usare un alesatore centesimale per compensare la variazione
	Pre-foro troppo piccolo	Diminuire lo spessore di sovrametallo da asportare
	Materiale eterogeneo con inclusioni d'elevata durezza	Usare un alesatore in metallo duro

FRESA A FILETTARE

INFORMAZIONI GENERALI SULLE FRESE A FILETTARE

1. La fresatura per filettare è un processo che genera un filetto per interpolazione di una fresa con una specifica geometria.
2. Per impiegare una fresa a filettare occorre impiegare una macchina a controllo numerico che possa eseguire una interpolazione.
3. I moderni centri di lavoro CNC sono dotati di programmi per l'esecuzione di fresature di filetti.
4. Consultate il manuale oppure contattate il fornitore della macchina per avere le informazioni

VANTAGGI E CARATTERISTICHE

1. La fresatura di filetti garantisce una maggiore affidabilità e una maggiore vita utensile
2. La fresatura di filetti produce un truciolo sottile che lascia il filetto libero
3. Tolleranze e regolazioni possono essere ottenuti con modifiche di programmazione
4. Si può ottenere un filetto completo fino al fondo del foro
5. Si può lavorare su un'ampia varietà di materiali
6. La stessa fresa può produrre differenti dimensioni di filetto purchè il passo sia il medesimo
7. Filetti sinistri e destri possono essere generati dal medesimo utensile
8. Alcune frese a filettare possono anche eseguire lo smusso in entrata (J200, J205, J260)

SCEGLIETE IL VOSTRO UTENSILE

Le frese a filettare hanno un codice basato sulla tipologia, diametro (d1) e passo (P).

Questo codice è il numero da utilizzare per ordinare l'utensile.

Consultare sempre il catalogo per essere sicuri di avere il passo corretto.

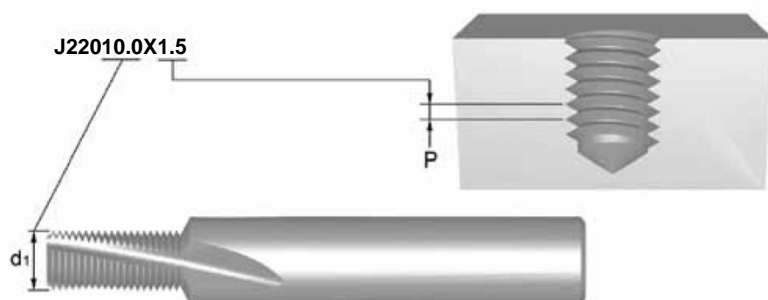

Questa fresa a filettare può essere impiegata per filettature \geq M12x1.5 (M14x1.5, M18x1.5 etc)

PROGRAMMARE CON Rprg

- Per una facile correzione della tolleranza del filetto si consiglia di programmare con la correzione del raggio
- Il valore Rprg è il valore iniziale per una nuova fresa ed è visibile nel gambo della fresa. Questo valore deve essere inserito nella memoria di programmazione.
- Rprg è basato sulla linea zero teorica del filetto, quindi se si programma con Rprg il filetto non sarà mai maggiorato, ma leggermente stretto
- Questo significa che con una leggera modifica alle coordinate si ottiene un filetto della grandezza richiesta

CONSIGLI

- Usare sempre i parametri indicati (vedere la tabella sul catalogo a pagina 198)
- Impiegare la punta del diametro indicato per il filetto da eseguire, come per i maschi convenzionali.
- Per una facile correzione della tolleranza del filetto iniziare sempre con il valore Rprg impresso sul gambo della fresa
- Impiegare un calibro per controllare le tolleranze del primo filetto se il raggio deve essere corretto. Il raggio può essere corretto 2 o 3 volte prima che la fresa sia usurata
- Nelle lavorazioni a secco, impiegare aria compressa per favorire l'evacuazione del truciolo
- Per filettare materiali difficili, occorre effettuare 2 o 3 passate

FILETTATURA

INFORMAZIONI GENERALI SULLA MASCHIATURA

Il successo di ogni operazione di filettatura dipende da vari fattori, che insieme influenzano la qualità del prodotto finito.

1. Selezionare il tipo di maschio più idoneo al tipo di materiale da lavorare e al tipo di foro, cioè passante o cieco, dalla tabella di classificazione dei materiali.
2. Assicurarci che il pezzo da lavorare sia bloccato saldamente – movimenti laterali possono causare la rottura del maschio o filetti di qualità scadente.
3. Scegliere il formato corretto della punta dalla rispettiva pagina del catalogo. Garantire sempre che l'incrudimento del materiale del componente sia mantenuto al minimo.
4. Selezionare la velocità di taglio più consona, come riportato sulla pagina del catalogo dedicata al prodotto.
5. Utilizzare il refrigerante idoneo per il tipo di applicazione.
6. In applicazioni CN assicurarsi che la velocità d'avanzamento sia corretta. In caso si utilizzi un mandrino portamaschio a compensazione si raccomanda un avanzamento pari al 95 - 97% del passo, per permettere al maschio di generare il proprio passo.
7. Dove possibile, bloccare saldamente il maschio con un mandrino porta-maschio di buona qualità e con limitazione della coppia massima, al fine di permettere un movimento assiale libero del maschio stesso, e assicurarsi che l'utensile si presenti perpendicolare al foro. Questo tipo di mandrino protegge inoltre il maschio da rotture, nel caso dovesse accidentalmente urtare contro il fondo di un foro cieco.
8. Assicurarci che il maschio entri dolcemente nel foro: un avanzamento sbagliato può causare fenomeni di "imboccatura a campana" (bell mouting).

TABELLA CLASSI DI TOLLERANZA DEL MASCHIO CONTRO TOLLERANZA DELLA FILETTATURA INTERNA (MADREVITE)

Classe Tolleranza, Maschio			Tolleranza, Filettatura Interna (Madrevite)					Applicazione
ISO	DIN	ANSI BS						
ISO 1	4 H	3 B	4 H	5 H				Accoppiamento preciso senza gioco
ISO 2	6 H	2 B	4 G	5 G	6 H			Accoppiamento normale
ISO 3	6 G	1 B			6 G	7 H	8 H	Accoppiamento con tolleranza ampia
-	7 G	-				7 G	8 G	Accoppiamento con gioco per successivo trattamento o rivestimento

RISOLUZIONE DEI PROBLEMI DURANTE LA FILETTATURA CON MASCHI

PROBLEMA	CAUSA	SOLUZIONE
Filettatura maggiorata	Tolleranza non corretta	Scegliere un maschio con tolleranza di filettatura inferiore
	Avanzamento assiale non corretto	Ridurre l'avanzamento del 5-10% o aumentare la compressione del mandrino porta maschio
	Tipo di maschio non adatto all'applicazione	Usare un maschio con imbocco corretto per fori passanti o un maschio con scanalature elicoidali per fori ciechi. Usare un utensile rivestito per prevenire la formazione del tagliente di riporto. Consultare il catalogo o il Web Selector per l'alternativa più idonea
	Maschio non centrato sul foro	Verificare le condizioni del mandrino porta-maschio e posizionare il centro del maschio sul foro
	Mancanza di lubrificazione	Assicurare una buona lubrificazione per prevenire la formazione del tagliente di riporto. Consultare la sezione sulla lubrificazione nel nostro manuale tecnico.
	Velocità di taglio del maschio troppo bassa	Seguire le raccomandazioni del catalogo/ Web Selector
Filettatura minorata	Tipo di maschio non adatto all'applicazione	Usare un maschio con imbocco corretto per fori passanti o un maschio con scanalature elicoidali per fori ciechi. Usare un utensile rivestito per prevenire la formazione del tagliente di riporto. Usare un maschio con angolo di taglio maggiore. Consultare il catalogo o il Web Selector per l'alternativa più idonea
	Tolleranza non corretta	Scegliere un maschio con tolleranza di filettatura maggiore, in particolare su materiali con bassa tendenza a creare filettature maggiorate (<i>oversize</i>), quali ghisa o acciaio inossidabile
	Lubrificazione non corretta o mancante	Assicurare una buona lubrificazione per prevenire l'intasamento del truciolo nel foro. Consultare la sezione sulla lubrificazione nel nostro manuale tecnico.
	Diametro di pre-foro troppo piccolo	Aumentare il diametro di pre-foro sino al valore massimo permesso. Verificare le tabelle dei preforni di maschiatura.
	Il materiale si richiude dopo la maschiatura	Consultare il catalogo o il <i>Web Selector</i> per scegliere l'utensile appropriato.
Scheggiatura	Tipo di maschio non adatto all'applicazione	Scegliere un maschio con angolo di taglio più basso e/o con imbocco spogliato più lungo. Usare un maschio con imbocco corretto per fori passanti o un maschio con scanalature elicoidali per fori ciechi, in modo da evitare l'intasamento dei trucioli nel foro. Usare un utensile rivestito per prevenire la formazione del tagliente di riporto. Consultare il catalogo o il Web Selector per l'alternativa più idonea.
	Lubrificazione non corretta o mancante	Assicurare una buona lubrificazione per evitare la formazione del tagliente di riporto. Consultare la sezione sulla lubrificazione nel nostro manuale tecnico.
	Il maschio urta contro il fondo del foro	Aumentare la profondità di foratura o diminuire la profondità di filettatura.
	Incrudimento superficiale del materiale lavorato	Ridurre la velocità, usare utensili rivestiti, assicurare una corretta lubrificazione. Consultare la sezione sulla lavorazione dell'acciaio inossidabile nel nostro manuale tecnico.
	Truciolo intrappolato durante la fase di ritorno	Evitare un'inversione improvvisa della rotazione del maschio.
	L'imbocco urta contro l'entrata del foro	Verificare la posizione assiale e ridurre l'errore assiale del centro del maschio rispetto al centro del foro.
	Diametro di pre-foro troppo piccolo	Aumentare il diametro di pre-foro sino al valore massimo permesso. Verificare le tabelle dei preforni di maschiatura.

RISOLUZIONE DEI PROBLEMI DURANTE LA FILETTATURA CON MASCHI

PROBLEMA	CAUSA	SOLUZIONE
Rottura	Maschio usurato	Usare un maschio nuovo o riaffilare il vecchio.
	Mancanza di lubrificazione	Assicurare una buona lubrificazione per evitare la formazione del tagliente di riporto e l'intasamento dei trucioli. Consultare la sezione sulla lubrificazione nel nostro manuale tecnico.
	Maschio urta contro il fondo del foro	Aumentare la profondità di foratura o diminuire la profondità di filettatura.
	Velocità di taglio del maschio troppo elevata	Ridurre la velocità di taglio. Seguire le raccomandazioni sul catalogo o sul Web Selector.
	Incrudimento superficiale del materiale lavorato	Ridurre la velocità. Usare utensili rivestiti. Assicurare una buona lubrificazione. Consultare la sezione sulla lavorazione dell'acciaio inossidabile nel nostro manuale tecnico.
	Diametro di pre-foro troppo piccolo	Aumentare il diametro di pre-foro sino al valore massimo permesso. Consultare le tabelle di riferimento.
	Coppia troppo alta	Usare un mandrino porta-maschio con frizione per la regolazione della coppia.
	Il materiale si richiude dopo la maschiatura	Seguire le raccomandazioni sul catalogo o sul Web Selector per l'utensile più idoneo.
Usura rapida	Tipo di maschio non adatto all'applicazione	Usare un maschio con angolo di taglio più basso e/o spoglia radiale più alta e/o imbocco più lungo. Usare un utensile rivestito. Consultare il catalogo o il Web Selector per l'alternativa più idonea.
	Mancanza di lubrificazione	Assicurare una buona lubrificazione per prevenire la formazione del tagliente di riporto e l'insorgere di stress termici sul tagliente. Consultare la sezione sulla lubrificazione nel nostro manuale tecnico.
	Velocità di taglio del maschio troppo elevata	Ridurre la velocità di taglio. Seguire le raccomandazioni riportate sul catalogo e sul Web Selector.
Tagliente di riporto	Tipo di maschio non adatto all'applicazione	Usare un maschio con un angolo di taglio più basso e/o con spoglia radiale più alta. Consultare il catalogo o il Web Selector per l'utensile più idoneo.
	Mancanza di lubrificazione	Assicurare una buona lubrificazione per evitare la formazione del tagliente di riporto. Consultare la sezione sulla lubrificazione nel nostro manuale tecnico.
	Trattamento superficiale non idoneo	Scegliere un maschio con rivestimento raccomandato.
	Velocità di taglio del maschio troppo bassa	Seguire le raccomandazioni sul catalogo o sul Web Selector.

Fresatura

INFORMAZIONI GENERALI SULLA FRESATURA

L'operazione di fresatura consiste nell'asportazione di materiale (sotto forma di truciolo) attraverso un movimento rotatorio dell'utensile fresa associato ad un movimento di avanzamento affidato al pezzo in lavoro o all'utensile stesso. La fresa è per definizione un utensile di rotazione dotato di un numero definito di taglienti, i quali entrano in contatto in maniera sequenziale con il pezzo in lavorazione.

TIPI DI FRESE

Le tre operazioni di fresatura di base sono descritte qui di seguito: (A) fresatura periferica, (B) fresatura frontale e (C) fresatura periferico - frontale.

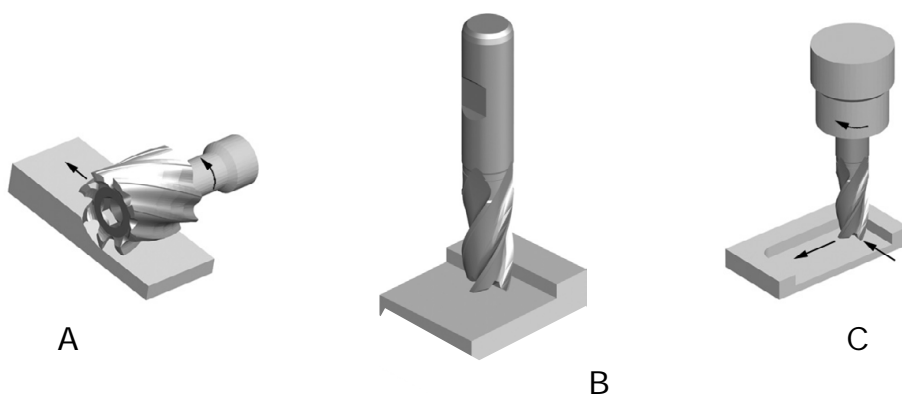

Nella fresatura periferica l'asse di rotazione della fresa è parallelo alla superficie in lavoro. La fresa è munita di una serie di denti disposti lungo la circonferenza, ogni dente agisce come un utensile da taglio a punta singola, definito fresa semplice. Le frese impiegate nella fresatura periferica possono essere dotate di denti dritti o elicoidali.

Nella fresatura frontale la fresa è montata su di un mandrino che ruota lungo un asse perpendicolare alla superficie in lavoro. I taglienti principali sono disposti in corrispondenza della base del corpo cilindrico fresa.

Nella fresatura periferico - frontale l'utensile fresa è dotato di taglienti principali (normalmente di tipo elicoidale) posizionati sulla superficie cilindrica, e di taglienti secondari posizionati frontalmente in corrispondenza della base cilindrica.

APPLICAZIONI

L'MRR ed i vari tipi di lavorazione sono fra loro strettamente legati. Ogni tipo di lavorazione è caratterizzata da un MRR specifico, il quale varia a seconda dei parametri di lavoro utilizzati: profondità assiale e radiale, avanzamento utensile. Il catalogo Dormer identifica le diverse applicazioni con l'ausilio di icone.

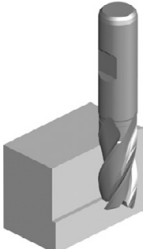
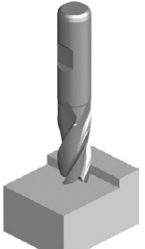
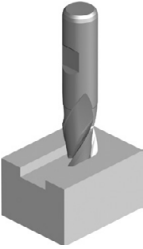
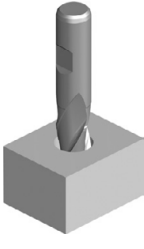
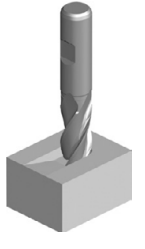
Finitura/semifinitura	Contornatura di sgrossatura	Fresatura di cave (*)	Fresatura "a Tuffo"	Fresatura a Rampa
				
La profondità radiale del taglio deve essere pari a 0.1 del diametro nominale fresa per operazioni di finitura e pari a 0.25 per fresatura di semifinitura.	La profondità radiale del taglio deve essere non superiore a 0.9 del diametro utensile.	La profondità radiale di taglio è pari al diametro della fresa.	Utilizzando frese con taglienti al centro è possibile effettuare operazioni di foratura. Nota: maggiori informazioni all'interno del paragrafo strategie di foratura.	L'utensile fresa è dotato di 2 movimenti combinati: assiale e radiale. Nota: maggiori informazioni all'interno del paragrafo riguardante le strategie di foratura.

RISOLUZIONE DEI PROBLEMI DURANTE LA FRESATURA

PROBLEMA	CAUSA	SOLUZIONE
Rottura	Eccessivo materiale asportato nell'unità di tempo (carico tagliente troppo elevato)	Diminuire l'avanzamento per dente
	Avanzamento troppo veloce	Ridurre avanzamento
Usura	Lunghezza tagliente o sporgenza utensile eccessiva	Posizionare codolo più in profondità all'interno del mandrino portautensili, usare una fresa più corta
	Materiale in lavoro caratterizzato da bassa lavorabilità	Consultare il catalogo o il Web Selector per definire l'utensile ed i parametri più idonei
	Avanzamento e velocità non corretti	Consultare il catalogo o il Web Selector per definire i parametri più idonei
	Scarsa rimozione del truciolo	Posizionare correttamente gli ugelli del lubrorefrigerante
	Fresatura convenzionale	Fresatura concorde
	Geometria – materiale – rivestimento utensile	Consultare il catalogo o il Web Selector per utensili più adeguati
Scheggiatura	Avanzamento utensile troppo alto	Ridurre avanzamento
	Vibrazione utensile	Ridurre il numero di giri/minuto
	Velocità di taglio bassa	Aumentare il numero di giri/minuto
	Aumentare il numero di giri/minuto	Fresatura concorde
	Bassa rigidità dell'utensile	Posizionare il codolo più in profondità all'interno del mandrino portautensili, usare una fresa più rigida (maggiore numero denti, minore lunghezza, massimo diametro utensile adottabile). Utilizzare sistemi porta utensili più rigidi (es.: calettamento a caldo)
	Rigidità del pezzo	Serrare bene il pezzo
Vita utensile breve	Materiale difficile da lavorare	Consultare il catalogo o Web Selector per un'alternativa di utensile più idonea
	Angolo di spoglia frontale o dorsale non idonei	Scegliere utensile con geometria adeguata
	Eccessiva temperatura raggiunta dai taglienti in lavoro	Usare un utensile rivestito
Scarsa finitura superficiale	Avanzamento troppo elevato	Ridurre l'avanzamento utensile
	Velocità di taglio troppo bassa	Aumentare la velocità di taglio
	Truciolo irregolare	Diminuire il quantitativo di sovrametallo asportato
	Usura eccessiva utensile	Sostituire o riaffilare l'utensile
	Formazione di tagliente di riporto	Utilizzare geometria idonea (angolo elica, angolo di spoglia dorsale e frontale)
	Saldatura del truciolo sui taglienti in lavoro	Aumentare il quantitativo di refrigerante

PROBLEMA	CAUSA	SOLUZIONE
Scarsa precisione dimensionale del pezzo lavorato	Flessione dell'utensile	Posizionare il codolo più in profondità all'interno del mandrino portautensili, usare una fresa più rigida (maggiore numero denti, minore lunghezza, massimo diametro utensile adottabile)
	Numero insufficiente di taglienti.	Usare un utensile con più taglienti.
	Portautensili usurato	Riparare o sostituire il portautensili
	Scarsa rigidità del portautensili	Sostituire con portautensili più rigido (es.: calettamento a caldo)
	Scarsa rigidità del mandrino	Usare mandrino di maggiori dimensioni
Vibrazione utensile	Avanzamento e velocità troppo elevate	Correggere avanzamento e velocità con l'ausilio del catalogo/ Web Selector
	Lunghezza tagliente o sporgenza utensile eccessiva	Posizionare il codolo più in profondità all'interno del mandrino portautensili, usare una fresa più corta
	Profondità assiale troppo elevata	Ridurre la profondità assiale
	Scarsa rigidità (sistema complessivo macchina e portautensili)	Verificare il portautensili e sostituirlo se necessario

LIME ROTATIVE

CONSIGLI GENERICI SULLE LIME ROTATIVE

Le lime rotative sono ampiamente usate per lavorare e finire componenti in una vasta gamma di materiali.

Sono generalmente impiegate a mano su utensili ad aria compressa

CARATTERISTICHE E VANTAGGI

Steli tenacizzati e induriti migliorano la rigidità e riducono il rischio di deformazioni e vibrazioni

Steli accuratamente rettificati migliorano il bloccaggio e riducono la possibilità di slittamenti

Una speciale saldo-brasatura previene il distacco in alte temperature e garantisce resistenza alla pressione e all'impatto

Geometria universale a doppio taglio adatta ad una vasta gamma di materiali e applicazioni

Sono anche disponibili specifiche geometrie per diversi materiali: Acciaio (ST), Acciaio inossidabile (VA), Alluminio (AL) e Fibreglass (GRP)

Disponibile con rivestimento TiAlN per un aumento di durata su materiali abrasivi

Le lime rotative a testa sferica sono rettificate con la geometria "Skip Flute"

Questa geometria è di fatto attiva fino al centro della lima, migliora l'azione di taglio e riduce le possibilità del tagliente di riporto e dell'incollamento

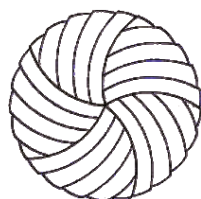

Skip

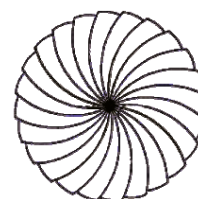

Normale

LA SICUREZZA PRIMA DI TUTTO

Le lime rotative ad alta velocità possono essere pericolose se impiegate male

Ricordarsi di staccare l'utensile dalla presa d'aria durante la sostituzione della lima rotativa

Controllare le condizioni dell'utensile e se possibile usare i tipi con basse vibrazioni

Impiegare sempre le appropriate protezioni ed assicurarsi che tutti i lavoratori siano protetti



Le dotazioni personali protettive devono sempre essere indossate

CONSIGLI

- Impiegare sempre il mandrino con l'appropriato numero di giri
- La manutenzione di routine degli utensili è importante, assicurarsi che siano oliati e che i cuscinetti non siano usurati
- Quando si cambia la lima occorre pulire sempre gli elementi bloccanti, pinze e coni interni del mandrino.
- Occorre cercare di evitare evitare shock meccanici e pesanti impatti della lima
- Occorre cercare di evitare shock termici non permettendo che la lima sia troppo sotto carico
- Non immergere la lima decisamente nel pezzo e non usarla in profondità negli spigoli o nei canali.

Soluzione problemi LIME ROTATIVE

PROBLEMA	CAUSA
Scheggiatura dente della lima	Giri troppo bassi, possono causare rimbalzo
	Eccentricità (mandrino usurato, pinza o cuscinetti)
	Immersione e inceppamento della lima nel pezzo in lavorazione
Incollamento sui taglienti	Lunghezza tagliente o lunghezza totale troppo elevata
	Geometria non corretta per il tipo di materiale
Usura prematura	Giri troppo elevati per il diametro della lima ed il tipo di materiale
	Eccentricità (mandrino usurato, pinza o cuscinetti)
Distacco della testa dal gambo	Giri troppo elevati possono causare surriscaldamento
	Lavorare per un periodo prolungato causa surriscaldamento

Deutsch		Härte	Zugfestigkeit	ISO
Anwendungsmaterialgruppen		HB	N/mm ²	
1. Stahl	1.1 Magnetweicheisen	< 120	< 400	P 1
	1.2 Baustahl, Einsatzstahl	< 200	< 700	P 1
	1.3 Kohlenstoffstahl	< 250	< 850	P 2
	1.4 Legierter Stahl	< 250	< 850	P 3
	1.5 Legierter und vergüteter Stahl	> 250 < 350	> 850 < 1200	P 4
	1.6 Legierter und vergüteter Stahl	> 350	> 1200 < 1620	H 1
	1.7 Legierter gehärteter Stahl	49-55HRC	> 1620	H 3
	1.8 Legierter gehärteter Stahl	55-63HRC	> 1980	H 4
2. Rostfreier Stahl	2.1 Rostfreier Stahl, geschwefelt	< 250	< 850	M 1
	2.2 Austenitisch	< 320	< 1100	M 3
	2.3 Ferritisch+Austenitisch, Martensitisch	< 300	< 1000	M 2
3. Gusseisen	2.4 Vergüteter rostfreier Stahl	> 320 < 410	> 1100 < 1400	S 2
	3.1 Grauguss	< 150	> 500	K 1
	3.2 Vergüteter Grauguss	> 150 < 300	> 500 < 1000	K 2
	3.3 Kugelgraphitguss, Temperguss	< 200	< 700	K 3
	3.4 Kugelgraphitguss, Temperguss	> 200 < 300	> 700 < 1000	K 4
	4.1 Reintitan	< 200	< 700	S 1
4. Titan	4.2 Titan-Legierungen	< 270	< 900	S 2
	4.3 Titan-Legierungen	> 270 < 350	> 900 ≤ 1250	S 3
	5.1 Reinnickel	< 150	< 500	S 1
5. Nickel	5.2 Nickel-Legierungen	< 270	> 900	S 2
	5.3 Nickel-Legierungen	> 270 < 350	> 900 < 1200	S 3
	6.1 Kupfer	< 100	< 350	N 3
6. Kupfer	6.2 Kurzspanendes Messing, Bronze	< 200	< 700	N 4
	6.3 Langspanendes Messing	< 200	< 700	N 3
	6.4 Cu-Al-Fe-Legierung, (Ampco)	< 470	< 1500	N 4
	7.1 Al, Mg, unlegiert	< 100	< 350	N 1
7. Aluminium Magnesium	7.2 Al legiert, Si < 0.5 %	< 150	< 500	N 1
	7.3 Al legiert, Si > 0.5 % < 10 %	< 120	< 400	N 1
	7.4 Al legiert, Si > 10 % Whisker verstärkte Al-Legierung, Mg-Legierung	< 120	< 400	N 2
8. Kunststoffe	8.1 Thermoplaste	---	---	O
	8.2 Duroplaste	---	---	O
	8.3 Faserverstärkte Kunststoffe	---	---	O
9. Hartstoffe	9.1 Cermets (Metallkeramik)	< 550	< 1700	H
10. Graphit	10.1 Graphit	---	< 100	O

BEISPIELE VON WERKSTÜCKMATERIALIEN
VERSCHIEDENER STANDARDS

AMG	EN	W.Nr.	DIN	BS	SS	USA	UNS	ISO
1.1	EN 10 025 - S235JRG2	1.1015, 1.1013	Rb60, Rb100	230Mn7, 050A12	1160	Leaded Steels	G12120	P 1
1.2	EN 10 025 - S235JRG2	1.1012, 1.1053, 1.17131	S137-2, 16MnCr5, S150-2	060A35, 080M40, 4360-50B	1312, 1412, 1914	135, 30	G10100	P 1
1.3	EN 10 025 - E295	1.1191, 1.0601	CK45, C60	080M46, 080A62	1550, 2142, 2172	1024, 1060, 1061	G10600	P 2
1.4	EN 10 083-1 - 42 CrMo 4 - EN 10 270-2	1.7225, 1.3505, 1.6582, 1.3247	42CrMo4, 100Cr6, 34CrNiMo6, S2-10-1-8	708M40/42, 817M40, 534A99, BM2, BT42	1672-04, 2090, 2244-02, 2541-02	4140, A2, 4340, M42, M2	G41270, G41470, T30102, T11342	P 3
1.5	EN ISO 4957 - HS6-5-25	1.2510, 1.2713, 1.3247, 1.2080	100MnCrW12, 5NiCrMoV6, X210Cr12, S2-10-1-8	B01, BM2, BT42, 826 M40, 830M31	2244-04, 2541-03, 2550, 2722, 2723	01, L6, M42, D3, A2, M2, 4140, 8630	G86300, T30102, T11302, T30403, T11342	P 4
1.6	EN ISO 4957 - HS2-9-1-8	1.2510, 1.2713, 1.3247, 1.2080	100MnCrW12, X210Cr12, S2-10-1-8	801, 826 M40, 830M31	2244-05, 2541-05, ,HARDOX 400	01, L6, M42, D3, 4140, 8130	T30403, G41400, J14047	H 1
1.7	EN ISO 4957 - HS2-9-1-8	1.2510	100MnCrW12	B01, BD3, BH13	HARDOX 500			H 3
1.8	EN ISO 4957 - X40CrMoV5-1	1.3343, 1.2344	S6-5-2, GX40CrMoV5-1	BM2, BH13	2242 HARDOX 600			H 4
2.1	EN 10 088-3 - X14CrMoS17	1.4305, 1.4104	X10CrNiS189, X12CrMoS17	303 S21, 416 S37	2301, 2312, 2314, 2346, 2380	303, 416, 430F	S30300, S41600, S43020	M 1
2.2	EN 10 088-2-0-3 - 1.4301+AT	1.4301, 1.4541, 1.4571	X5CrNi189 X10CrNiMoTi1810	304 S15, 321 S17, 316 S, 320 S12	2310, 2333, 2337, 2343, 2353, 2377	304, 321, 316	S50400, S32100, S31600	M 3
2.3	EN 10 088-3 - 1.4460	1.4460, 1.4512, 1.4582	X8CrNiMo275, X4CrNiMoN6257	317 S16, 316 S16	2324, 2387, 2570	409, 430, 436	S40900, S4300, S43600	M 2
2.4	EN 1 4547	1.4547	X2CrNiMo20-18-6	HR41	2378	17-4PH	S31254	S 2
3.1	EN 1561 - EN-JL1030	0.6010, 0.6040	GG10, GG40	Grade150, Grade 400	0120, 0212, 0814	ASTM A48 class 20	F11401, F12801	K 1
3.2	EN 1561 - EN-JL1050	0.6025, 0.6040	GG25, GG40	Grade200, Grade 400	0125, 0130, 0140, 0217	ASTM A48 class 40, STM A48 class 60	F12801, F14101	K 2
3.3	EN 1561 - EN-JL2040	0.7040, 0.7070, 0.8145, 0.8045	GG40, GGG70, GTS45-06, GTW45-07	42012, P44007, 7002, 30g/72	0219, 0717, 0727, 0732, 0852	ASTM A220 grade 40010, ASTM A602 grade M4504	F22830, F20001	K 3
3.4	EN 1561 - EN-JL2050	0.7040, 0.7070, 0.8145, 0.8045	GG40, GGG70, GTS45-06, GTW45-07	42012, P44007, 7002, 30g/72	0221, 0223, 0737, 0854	ASTM A220 grade 90001, ASTM A602 grade M8501	F26230, 20005	K 4
4.1		3.7024LN	T89.8	TA1 to 9	T89.8	ASTM B265 grade 1	R50250	S 1
4.2		3.7164LN, 3.7119LN	TA16V4, TA165n2	TA10 to 14, TA17	TA16V4, TA165n2	AMS4928	R54790	S 2
4.3		3.7164LN, 3.7174LN, 3.7184LN	TA16V4, TA16V5Sn2, TA14MoSn2	TA10 to 13, TA28	TA16V5Sn2	AMS4928, AMS4971	R56400, R54790	S 3
5.1		2.4060, 2.4066	Nickel 200, 270, N189.6	NA 11, NA12	N1200, N1270	Nickel 200, Nickel 230	N02200, N02230	S 1
5.2		2.4630LN, 2.4602, 2.4650LN	Nimonic 75, Monel 400, Hastelloy C, Inconel 600	HR203, 3027-76		Nimonic 75, Monel 400, Hastelloy, Inconel 600	N06075, N10002, N04400, N06600	S 2
5.3		2.4668LN, 2.4631LN, 2.6554LN	Inconel 718, Nimonic 80A, Waspaloy	HR8, HR401, 601		Inconel 718, 625, Nimonic 80	N07718, N07080, N06625	S 3
6.1	EN 1652 - CW004A	2.0060, 2.0070	E-Cu57, SE-Cu	C101	5010	101	C10100, C1020	N 3
6.2	EN 1652 - CW612N	2.0360, 2.0360, 2.1030, 2.1080	CuZn39Pb2, CuZn40, CuSn8, CuSn6Zn	CZ120, CZ109, PB104	5168		C28000, C37710	N 4
6.3	EN 1652 - CW508L	2.0321, 2.0260	CuZn37, CuZn28	CZ108, CZ106	5150		C2600, C37720	N 3
6.4			Ampco 18, Ampco 25	AB1 type	5238, JIM7-20			N 4
7.1	EN 485-2 - EN AW-1070A	3.0255	Al99.5	LM0, 1 B (1050A)	4005	EC, 1060, 1100	A91060, A91100	N 1
7.2	EN 755-2 - EN AW-5005	3.1355, 3.3525	AlCuMg2, AlMg2Mn0.8	LM5, 10, 12, N4 (6251)	4106, 4212	380, 520.0, 520.2, 2024, 6061	A03800, A05200, A92024	N 1
7.3	EN 1706 - EN AC-42000	3.2162.05, 3.2341.01	GD-AS18Cu, G-AS5Mg	LM2, 4, 16, 18, 21, 22, 24, 25, 26, 27, L109	4244	319.0, 333.0, 319.1, 356.0	A03190, A03330, C35600	N 1
7.4	SS-EN 1706 - EN AC-47000	3.2581.01	G-AS18, G-AS112	LM6, 12, 13, 20, 28, 29, 30	4260, 4261, 4262	4032, 222.1, A332.0	A94032, A02220, A13320	N 2
8.1				Polystyrene, Nylon, PVC Cellulose, Acetate & Nitrate		Polystyrene, Nylon, PVC		O
8.2				Ebonite, Tufnol, Bakelite		Bakelite		O
8.3				Kevlar, Printed Circuit boards		Kevlar		O
9.1				Ferroc, Ferrotitanit				H
10.1				Graphite				O

		Vc															
m/min		5	8	10	15	20	25	30	40	50	60	70	80	90	100	110	150
Feet/min		16	26	32	50	66	82	98	130	165	197	230	262	296	330	362	495
Ø		U/min															
mm	inch																
1,00		1592	2546	3183	4775	6366	7958	9549	12732	15916	19099	22282	25465	28648	31831	35014	47747
1,50		1061	1698	2122	3183	4244	5305	6366	8488	10610	12732	14854	16977	19099	21221	23343	31831
2,00		796	1273	1592	2387	3183	3979	4775	6366	7958	9549	11141	12732	14324	15916	17507	23873
2,50		637	1019	1273	1910	2546	3183	3820	5093	6366	7639	8913	10186	11459	12732	14006	19099
3,00		531	849	1061	1592	2122	2653	3183	4244	5305	6366	7427	8488	9549	10610	11671	15916
3,18	1/8	500	801	1001	1501	2002	2502	3003	4004	5005	6006	7007	8008	9009	10010	11011	15015
3,50		455	728	909	1364	1819	2274	2728	3638	4547	5457	6366	7276	8185	9095	10004	13642
4,00		398	637	796	1194	1592	1989	2387	3183	3979	4775	5570	6366	7162	7958	8754	11937
4,50		354	566	707	1061	1415	1768	2122	2829	3537	4244	4951	5659	6366	7074	7781	10610
4,76	3/16	334	535	669	1003	1337	1672	2006	2675	3344	4012	4681	5350	6018	6687	7356	10031
5,00		318	509	637	955	1273	1592	1910	2546	3183	3820	4456	5093	5730	6366	7003	9549
6,00		265	424	531	796	1061	1326	1592	2122	2653	3183	3714	4244	4775	5305	5836	7958
6,35	1/4	251	401	501	752	1003	1253	1504	2005	2506	3008	3509	4010	4511	5013	5514	7519
7,00		227	364	455	682	909	1137	1364	1819	2274	2728	3183	3638	4093	4547	5002	6821
7,94	5/16	200	321	401	601	802	1002	1203	1604	2004	2405	2806	3207	3608	4009	4410	6013
8,00		199	318	398	597	796	995	1194	1592	1989	2387	2785	3183	3581	3979	4377	5968
9,00		177	283	354	531	707	884	1061	1415	1768	2122	2476	2829	3183	3537	3890	5305
9,53	3/8	167	267	334	501	668	835	1002	1336	1670	2004	2338	2672	3006	3340	3674	5010
10,00		159	255	318	477	637	796	955	1273	1592	1910	2228	2546	2865	3183	3501	4775
11,11	7/16	143	229	287	430	573	716	860	1146	1433	1719	2006	2292	2579	2865	3152	4298
12,00		133	212	265	398	531	663	796	1061	1326	1592	1857	2122	2387	2653	2918	3979
12,70	1/2	125	201	251	376	501	627	752	1003	1253	1504	1754	2005	2256	2506	2757	3760
14,00		114	182	227	341	455	568	682	909	1137	1364	1592	1819	2046	2274	2501	3410
14,29	9/16	111	178	223	334	446	557	668	891	1114	1337	1559	1782	2005	2228	2450	3341
15,00		106	170	212	318	424	531	637	849	1061	1273	1485	1698	1910	2122	2334	3183
15,88	5/8	100	160	200	301	401	501	601	802	1002	1203	1403	1604	1804	2004	2205	3007
16,00		99	159	199	298	398	497	597	796	995	1194	1393	1592	1790	1989	2188	2984
17,46	11/16	91	146	182	273	365	456	547	729	912	1094	1276	1458	1641	1823	2005	2735
18,00		88	141	177	265	354	442	531	707	884	1061	1238	1415	1592	1768	1945	2653
19,05	3/4	84	134	167	251	334	418	501	668	835	1003	1170	1337	1504	1671	1838	2506
20,00		80	127	159	239	318	398	477	637	796	955	1114	1273	1432	1592	1751	2387
24,00		66	106	133	199	265	332	398	531	663	796	928	1061	1194	1326	1459	1989
25,00		64	102	127	191	255	318	382	509	637	764	891	1019	1146	1273	1401	1910
27,00		59	94	118	177	236	295	354	472	589	707	825	943	1061	1179	1297	1768
30,00		53	85	106	159	212	265	318	424	531	637	743	849	955	1061	1167	1592
32,00		50	80	99	149	199	249	298	398	497	597	696	796	895	995	1094	1492
36,00		44	71	88	133	177	221	265	354	442	531	619	707	796	884	973	1326
40,00		40	64	80	119	159	199	239	318	398	477	557	637	716	796	875	1194
50,00		32	51	64	95	127	159	191	255	318	382	446	509	573	637	700	955

HV	HRC	HB		
Vickers	Rockwell	Brinell	N/ mm ²	Tons/ sq. in.
940	68			
900	67			
864	66			
829	65			
800	64			
773	63			
745	62			
720	61			
698	60			
675	59			
655	58		2200	142
650		618	2180	141
640		608	2145	139
639	57	607	2140	138
630		599	2105	136
620		589	2070	134
615	56	584	2050	133
610		580	2030	131
600		570	1995	129
596	55	567	1980	128
590		561	1955	126
580		551	1920	124
578	54	549	1910	124
570		542	1880	122
560	53	532	1845	119
550		523	1810	117
544	52	517	1790	116
540		513	1775	115
530		504	1740	113
527	51	501	1730	112
520		494	1700	110
514	50	488	1680	109
510		485	1665	108
500		475	1630	105
497	49	472	1620	105
490		466	1595	103
484	48	460	1570	102
480		456	1555	101
473	47	449	1530	99
470		447	1520	98
460		437	1485	96
458	46	435	1480	96
450		428	1455	94
446	45	424	1440	93
440		418	1420	92

HV	HRC	HB		
Vickers	Rockwell	Brinell	N/ mm ²	Tons/ sq. in.
434	44	413	1400	91
423	43	402	1360	88
413	42	393	1330	86
403	41	383	1300	84
392	40	372	1260	82
382	39	363	1230	80
373	38	354	1200	78
364	37	346	1170	76
355	36	337	1140	74
350		333	1125	73
345	35	328	1110	72
340		323	1095	71
336	34	319	1080	70
330		314	1060	69
327	33	311	1050	68
320		304	1030	67
317	32	301	1020	66
310	31	295	995	64
302	30	287	970	63
300		285	965	62
295		280	950	61
293	29	278	940	61
290		276	930	60
287	28	273	920	60
285		271	915	59
280	27	266	900	58
275		261	880	57
272	26	258	870	56
270		257	865	56
268	25	255	860	56
265		252	850	55
260	24	247	835	54
255	23	242	820	53
250	22	238	800	52
245		233	785	51
243	21	231	780	50
240		228	770	50
235		223	755	49
230		219	740	48
225		214	720	47
220		209	705	46
215		204	690	45
210		199	675	44
205		195	660	43
200		190	640	41

Tol	Ø mm							
	> 1 ≤ 3	> 3 ≤ 6	> 6 ≤ 10	> 10 ≤ 18	> 18 ≤ 30	> 30 ≤ 50	> 50 ≤ 80	> 80 ≤ 120
	µm							
e8	-14 / -28	-20 / -38	-25 / -47	-32 / -59	-40 / -73	-50 / -89	-60 / -106	-72 / -126
f6	-6 / -12	-10 / -18	-13 / -22	-16 / -27	-20 / -33	-25 / -41	-30 / -49	-36 / -58
f7	-6 / -16	-10 / -22	-13 / -28	-16 / -34	-20 / -41	-25 / -50	-30 / -60	-36 / -71
h6	0 / -6	0 / -8	0 / -9	0 / -11	0 / -13	0 / -16	0 / -19	0 / -22
h7	0 / -10	0 / -12	0 / -15	0 / -18	0 / -21	0 / -25	0 / -30	0 / -35
h8	0 / -14	0 / -18	0 / -22	0 / -27	0 / -33	0 / -39	0 / -46	0 / -54
h9	0 / -25	0 / -30	0 / -36	0 / -43	0 / -52	0 / -62	0 / -74	0 / -87
h10	0 / -40	0 / -48	0 / -58	0 / -70	0 / -84	0 / -100	0 / -120	0 / -140
h11	0 / -60	0 / -75	0 / -90	0 / -110	0 / -130	0 / -160	0 / -190	0 / -220
h12	0 / -100	0 / -120	0 / -150	0 / -180	0 / -210	0 / -250	0 / -300	0 / -350
k10	+40 / 0	+48 / 0	+58 / 0	+70 / 0	+84 / 0	+100 / 0	+120 / 0	+140 / 0
k12	+100 / 0	+120 / 0	+150 / 0	+180 / 0	+210 / 0	+250 / 0	+300 / 0	+350 / 0
m7	+2 / +12	+4 / +16	+6 / +21	+7 / +25	+8 / +29	+9 / +34	+11 / +41	+13 / +48
js14	+/- 125	+/- 150	+/- 180	+/- 215	+/- 260	+/- 310	+/- 370	+/- 435
js16	+/- 300	+/- 375	+/- 450	+/- 550	+/- 650	+/- 800	+/- 950	+/- 1100
H7	+10 / 0	+12 / 0	+15 / 0	+18 / 0	+21 / 0	+25 / 0	+30 / 0	+35 / 0
H8	+14 / 0	+18 / 0	+22 / 0	+27 / 0	+33 / 0	+39 / 0	+46 / 0	+54 / 0
H9	+25 / 0	+30 / 0	+36 / 0	+43 / 0	+52 / 0	+62 / 0	+74 / 0	+87 / 0
H12	+100 / 0	+120 / 0	+150 / 0	+180 / 0	+210 / 0	+250 / 0	+300 / 0	+350 / 0
P9	-6 / -31	-12 / -42	-15 / -51	-18 / -61	-22 / -74	-26 / -86	-32 / -106	-37 / -124

1µm = 0.001 mm

BOHREN

ALLGEMEINE HINWEISE ZUM BOHREN

1. Die Auswahl des besten Bohrers für die Anwendung erfolgt unter Berücksichtigung des zu bearbeitenden Materials, Eigenschaft des Werkzeugs und der Kühlung.
2. Immer auf maximale Stabilität achten, da Instabilitäten des Werkstückes und/oder der Werkzeugspindel den Bohrer, das Werkstück sowie die Maschine beschädigen können. Es sollte immer der kürzest mögliche Bohrer gewählt werden.
3. Werkzeugspannung ist ein wichtiger Aspekt beim Bohrvorgang. Der Bohrer darf sich keinesfalls im Werkzeughalter auf irgendeine Art bewegen.
4. Die Nutzung geeigneter Kühl- und Schmiermittel je nach Bohrvorgang ist empfehlenswert. Beim Einsatz von Kühl- und Schmiermitteln auf eine ausgiebige Zufuhr achten, besonders an der Bohrspitze.
5. Der Spanabtransport beim Bohren ist entscheidend, um einen korrekten Bohrvorgang zu gewährleisten. Ein Spanstau in den Nuten muss vermieden werden.
6. Beim Nachschleifen eines Bohrers immer darauf achten, dass die korrekte Spitzengeometrie erzeugt und Verschleiß entfernt wurde.

BOHRUNGSGRÖSSE

In dem Maße wie Geometrien, Trägermaterialien und Beschichtungen weiterentwickelt werden, erreicht man immer präzisere Bohrungsgrößen. Allgemein erreicht ein Werkzeug mit Standardgeometrie eine Bohrungsgröße bis H12. Für komplexere Bohrerkonfigurationen können unter günstigen Bedingungen H8-Bohrungstoleranzen realisiert werden. Für eine bessere Übersicht sind im folgenden die Produkttypen und ihre erreichbaren Bohrungsgrößen aufgelistet:

- HSS Standardbohrer – H12
- HSS / HSS-E Tieflochbohrer mit parabolischen Nuten – H10
- Beschichtete Hochleistungs VHM-Bohrer – H8/H9

STRATEGIE FÜR DAS TIEFLOCHBOHREN

Bei großen Bohrtiefen kann die nötige Tiefe mit verschiedenen Methoden erreicht werden. Das folgende Beispiel zeigt vier Wege, eine Bohrung von 10xD Tiefe zu erzeugen.

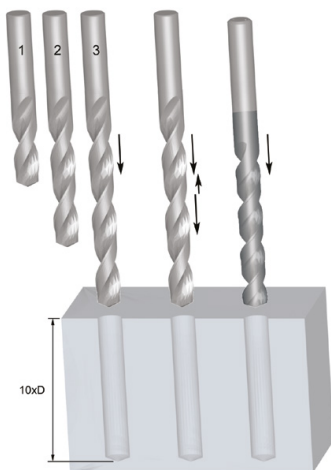

	Serienbohrung	Serienbohrung
Bohreranzahl	3 (2,5xD, 6xD, 10xD)	2 (2,5xD, 10xD)
Bohrertyp	Standardgeometrie, allgemeine Verwendung	Standardgeometrie, allgemeine Verwendung
+ / -	Teuer Zeitaufwendig	Kostengünstiger Schnell

	Bohren mit Entspanen	Bohren ohne Entspanen
Bohreranzahl	1 (10xD)	1 (10xD)
Bohrertyp	Standardgeometrie, allgemeine Verwendung	Anwendung spezifische Werkzeuge
+ / -	Zeitaufwendig	Kostengünstig Schnell

FEHLERSUCHE BEIM BOHREN

PROBLEM	URSACHE	ABHILFE
Abgebrochene oder verformte Mitnehmer	Schlechter Sitz zwischen Schaft und Spannmittel	Schaft und Spannmittel sauber und unbeschädigt halten
Riss im Kern	Vorschub zu hoch	Vorschub bis zum optimalen Wert verringern
	Zu wenig Hinterschliff	Nach korrekter Spezifikation nachschleifen
	Kernausspitzung zu stark	Nach korrekter Spezifikation nachschleifen
	Schlag auf die Querschneide	Schlag auf die Querschneide vermeiden. Morsekegelbohrer vorsichtig in die Spindel einsetzen bzw. austreiben
Eckenverschleiß	Überhöhte Drehzahl	Drehzahl auf das Optimum verringern - möglicherweise Erhöhung des Vorschubs
Ausbruch der Außenkanten	Instabile Arbeitsverhältnisse	Spindelspiel beseitigen
Ausbruch der Schneidkanten	Zu viel Hinterschliff	Nach korrekter Spezifikation nachschleifen
Bruch des Schaftauslaufs	“Abwürgen” der Nuten	Entspanen bzw. Serienbohrung anwenden
	Abrutschen des Bohrers	Sicherstellen, dass der Bohrer sicher in Spannfutter und Spindel sitzt
Spiralenförmiger Abschluss im Kernloch	Vorschub zu gering	Vorschub erhöhen
	Schlechte Positionsgenauigkeit	Bohrung vorher anzentrieren
Bohrungstoleranz zu groß	Falsche Spitzengeometrie	Spitzengeometrie prüfen
	Spanabfuhr nicht effektiv	Drehzahl, Vorschub und Bohrtiefe anpassen, um besseren Spanfluss zu erhalten

REIBEN

ALLGEMEINE HINWEISE ZUM REIBEN

Um die besten Ergebnisse bei der Benutzung von Reibahlen zu erzielen, ist es wichtig, dass sie zerspanen. Es ist ein typischer Fehler, die Bohrung, die gerieben werden soll, mit zu wenig Aufmaß vorzubereiten. Wenn vor dem Reiben zu wenig Material in der Bohrung verbleibt, wird die Reibahle anfangen zu schaben bzw. sehr schnell verschleifen, was zu einem geringeren Durchmesser führt. Es ist aber auch wichtig, nicht zu viel Material in der Bohrung zu belassen. (Siehe Materialabtrag weiter unten).

1. Den optimalen Reibahlen-Typ sowie die optimalen Drehzahlen und Vorschübe für die Anwendung auswählen. Die vorgebohrten Kernlöcher sollten den korrekten Durchmesser haben.
2. Das Werkstück muss fest eingespannt sein und die Maschinenspindel sollte kein Spiel haben.
3. Das Spannfutter für Reibahlen mit Zylinderschaft sollte über eine gute Qualität verfügen. Wenn die Reibahle bei automatischem Vorschub im Spannfutter rutscht, kann diese brechen.
4. Der Überhang vom Werkzeug zur Maschinenspindel sollte so gering wie möglich gehalten werden.
5. Empfohlene Schmiermittel verwenden, um eine möglichst hohe Standzeit des Werkzeugs zu erreichen. Darauf achten, dass es die Schnittkanten erreicht. Da Reiben keine schwere Schnittoperation darstellt, ist eine lösliche Öl 40:1-Verdünnung normalerweise zufriedenstellend. Bei Trockenbearbeitung in Grauguss kann mit Pressluft gearbeitet werden.
6. Die Nuten einer Reibahle dürfen nicht durch Späne blockiert werden.
7. Bevor die Reibahle nachgeschliffen wird, sollte die Rundlaufgenauigkeit zwischen den Zentrierbohrungen überprüft werden. In den meisten Fällen muss nur der Anschnitt nachgeschliffen werden.
8. Reibahlen scharf halten. Regelmäßiges Nachschleifen ist ökonomisch sinnvoll, allerdings ist es wichtig zu verstehen, dass die Reibahle nur mit dem Anschnitt schneidet, nicht mit der Fase. Aus diesem Grund muss nur der Anschnitt nachgeschliffen werden. Die Genauigkeit beim Nachschleifen ist wichtig für die Bohrungsqualität und Standzeit des Werkzeugs.

MATERIALABTRAG

Die empfohlene Materialmenge, die abgetragen werden soll, hängt vom Anwendungsmaterial und der Oberfläche der vorgebohrten Bohrung ab. Allgemeine Richtlinien für Materialabtrag werden in der folgenden Tabelle aufgelistet:

Größe der aufgeriebenen Bohrung (mm)	Wenn vorgebohrt	Wenn aufgebohrt	Größe der aufgeriebenen Bohrung (Zoll)	Wenn vorgebohrt	Wenn aufgebohrt
Unter 4	0.1	0.1	Unter 3/16	0.004	0.004
Über 4 bis 11	0.2	0.15	3/16 bis 1/2	0.008	0.006
Über 11 bis 39	0.3	0.2	1/2 bis 1,1/2	0.010	0.008
Über 39 bis 50	0.4	0.3	1,1/2 bis 2	0.016	0.010

TOLERANZGRENZEN



1. AUF DEM SCHNEIDENDURCHMESSER VON STANDARD-REIBAHLEN

Der Durchmesser (d_1) wird über die kreisförmige Fase hinweg direkt hinter dem Anschnitt oder der Kegelführung gemessen. Die Toleranz in Übereinstimmung mit der DIN 1420 ist dazu gedacht, H7 Bohrungen zu erzeugen.

REIBAHLEN-TOLERANZ			
Durchmesser (mm)		Toleranzgrenze (mm)	
Über	Bis einschließlich	Hoch +	Niedrig +
	3	0.008	0.004
3	6	0.010	0.005
6	10	0.012	0.006
10	18	0.015	0.008

REIBAHLEN-TOLERANZ			
Durchmesser (mm)		Toleranzgrenze (mm)	
Über	Bis einschließlich	Hoch +	Niedrig +
18	30	0.017	0.009
30	50	0.021	0.012
50	80	0.025	0.014

2. BEI EINER H7 BOHRUNG

Die normale Toleranz einer fertigen Bohrung ist H7 (siehe Tabelle unten). Für alle anderen Toleranzen können die Werte aus der Abbildung und der Tabelle unter Punkt 3 zur Berechnung des gewünschten Toleranzbereiches verwendet werden.

BOHRUNGSTOLERANZ			
Durchmesser (mm)		Toleranzgrenze (mm)	
Über	Bis einschließlich	Hoch +	Niedrig +
	3	0.010	0
3	6	0.012	0
6	10	0.015	0
10	18	0.018	0

BOHRUNGSTOLERANZ			
Durchmesser (mm)		Toleranzgrenze (mm)	
Über	Bis einschließlich	Hoch +	Niedrig +
18	30	0.021	0
30	50	0.025	0
50	80	0.030	0

3. Diese Tabelle kann zur Definition der Dimensionen einer speziellen Reibahle genutzt werden, um gemäß einer spezifischen Toleranz zu zerspanen, z. B. D8.

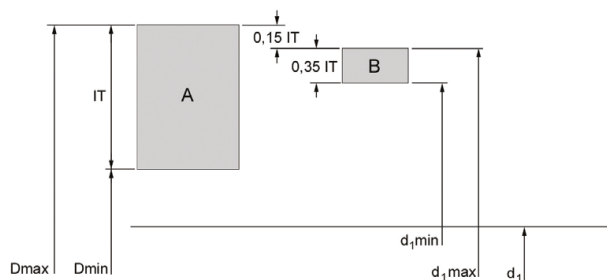

- A = Bohrungstoleranz
- B = Reibahlen-Toleranz
- IT = Toleranzbereich
- Dmax = Maximaler Bohrungsdurchmesser
- Dmin = Minimaler Bohrungsdurchmesser
- d_1 = Nominaler Durchmesser
- $d_{1,max}$ = Maximaler Durchmesser der Reibahle
- $d_{1,min}$ = Minimaler Durchmesser der Reibahle

Toleranzbereich (Mikron)	Durchmesser Toleranzbereich (mm)							
	Über 1 bis 3	Über 3 bis 6	Über 6 bis 10	Über 10 bis 18	Über 18 bis 30	Über 30 bis 50	Über 50 bis 80	Über 80 bis 120
IT5	4	5	6	8	9	11	13	15
IT6	6	8	9	11	13	16	19	22
IT7	10	12	15	18	21	25	30	35
IT8	14	18	22	27	33	39	46	54
IT9	25	30	36	43	52	62	74	87
IT10	40	48	58	70	84	100	120	140
IT11	60	75	90	110	130	160	190	220
IT12	100	120	150	180	210	250	300	350

z. B. 10 mm Bohrung mit Toleranz D8; Maximaler Bohrungsdurchmesser = 10,062; Minimaler Bohrungsdurchmesser = 10,040; Bohrungstoleranz (IT8) = 0,022

Maximalgrenze: $0,15 \times \text{Bohrungstoleranz (IT8)} = 0,0033$; aufgerundet = 0,004
 Minimalgrenze: $0,35 \times \text{Bohrungstoleranz (IT8)} = 0,0077$; aufgerundet = 0,008

Maximalgrenze für Reibahle = $10,062 - 0,004 = 10,058$
 Minimalgrenze für Reibahle = $10,058 - 0,008 = 10,050$

FEHLERSUCHE BEIM REIBEN

PROBLEM	URSACHE	ABHILFE
Abgebrochene oder verdrehte Mitnehmer	Inkorrekter Sitz zwischen Schaft und Spannmittel	Schaft und Spannmittel sauber und unbeschädigt halten
Schneller Werkzeugverschleiß	Zu wenig Aufmaß	Aufmaß vergrößern
Übermaß Bohrung	Übermäßige Schneidhöhen-Differenz	Nach korrekten Spezifikationen nachschleifen
	Kein korrekter Sitz in der Maschinenspindel	Spindel reparieren und Sitz korrigieren
	Beschädigungen am Werkzeughalter	Werkzeughalter ersetzen
	Werkzeugschaft ist beschädigt	Werkzeug ersetzen oder Schaft nachschleifen
	Rundlauffehler	Werkzeug ersetzen oder nachschleifen
	Asymmetrischer Anschnittwinkel	Nach korrekten Spezifikationen nachschleifen
	Vorschub oder Schnittgeschwindigkeit zu groß	Schnittbedingungen gemäß Katalog anpassen
Untermaß Bohrung	Zu wenig Aufmaß	Aufmaß vergrößern
	Zu große Hitzeentwicklung beim Reiben. Die Bohrung weitet sich und zieht sich wieder zusammen	Kühlmittelfluss erhöhen
	Der Werkzeugdurchmesser ist abgenutzt und Untermaß	Nach korrekten Spezifikationen nachschleifen
	Vorschub oder Schnittgeschwindigkeit zu gering	Schnittbedingungen gemäß Katalog anpassen
	Vorgebohrtes Kernloch zu eng	Aufmaß verringern
Ovale oder konische Bohrungen	Kein korrekter Sitz in der Maschinenspindel	Spindel reparieren und Sitz korrigieren
	Ausrichtungsfehler zwischen Werkzeug und Bohrung	Eine stirnschneidende Reibahle verwenden
	Asymmetrischer Anschnittwinkel	Nach korrekten Spezifikationen nachschleifen
Schlechte Oberflächenqualität der Bohrung	Zu viel Aufmaß	Aufmaß verringern
	Abgenutztes Werkzeug	Nach korrekten Spezifikationen nachschleifen
	Zu geringer Spanwinkel	Nach korrekten Spezifikationen nachschleifen
	Emulsion oder Bohröl zu stark verdünnt	Konzentration (%) erhöhen
	Vorschub und/oder Drehzahl zu gering	Schnittbedingungen gemäß Katalog anpassen
	Schnittgeschwindigkeit zu hoch	Schnittbedingungen gemäß Katalog anpassen
Das Werkzeug klemmt und zerbricht	Abgenutztes Werkzeug	Nach korrekten Spezifikationen nachschleifen
	Die "Halslänge" des Werkzeugs ist zu kurz	Werkzeug überprüfen und ersetzen/anpassen
	Die Breite der Fase ist zu groß	Werkzeug überprüfen und ersetzen/anpassen
	Werkstück-Material neigt zum Klemmen	Einstellbare Reibahle zur Kompensation der Toleranz benutzen
	Vorgebohrtes Kernloch zu eng	Aufmaß verringern
	Heterogenes Material mit Einschlüssen	Vollhartmetall-Reibahle verwenden

GEWINDEFRÄSEN

ALLGEMEINE HINWEISE ZUM GEWINDEFRÄSEN

1. Gewindefräsen ist der Prozess der Herstellung eines Gewindes durch die Kreisinterpolation eines Gewindefräasers mit einer spezifischen Gewindegeometrie entlang der Peripherie.
2. Um einen Gewindefräser verwenden zu können, wird eine CNC-Maschine benötigt, die in einer kreisförmigen Bahn arbeiten kann.
3. Die meisten modernen CNC-Maschinen besitzen Bearbeitungszyklen für das Gewindefräsen.
4. Ziehen Sie für weitere Informationen das Handbuch zu Rate oder wenden Sie sich an Ihren Maschinenlieferanten.

MERKMALE UND VORTEILE

1. Gewindefräsen sorgt für eine erhöhte Zuverlässigkeit und eine längere Werkzeugstandzeit.
2. Beim Gewindefräsen entstehen kleine Späne, was das problemlose Gewindeschneiden ermöglicht.
3. Toleranz-Veränderungen können mit genauen Koordinaten vorgenommen werden.
4. Es kann ein Gewinde bis zum Bohrungsgrund produziert werden.
5. Es kann eine große Vielfalt von Materialien verarbeitet werden.
6. Mit ein und demselben Fräser können verschiedene Gewindegrößen hergestellt werden, sofern die Steigung identisch ist.
7. Es können sowohl Rechts- als auch Linksgewinde mit demselben Werkzeug hergestellt werden.
8. Einige Gewindefräser können auch die Eingriff der Fase bearbeiten (J200, J205, J260).

WERKZEUGAUSWAHL

Gwindefräser sind mit einer Werkzeugbezeichnung versehen, in Abhängigkeit von Typ, Durchmesser (d_1) und Steigung (P).

Die Werkzeugbezeichnung sollte zur Bestellung des Werkzeugs benutzt werden.

Ziehen Sie immer den Katalog zu Rate um sicherzustellen, dass Sie mit den korrekten Gewindemaßen arbeiten.

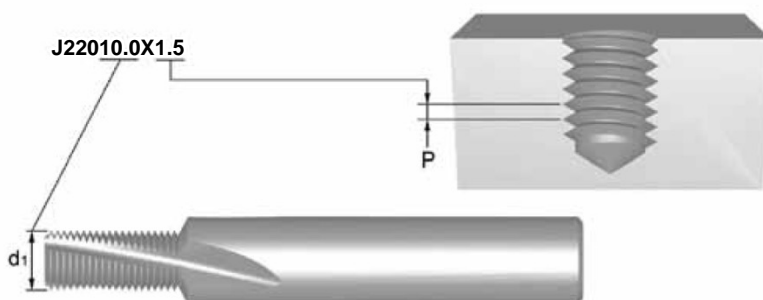

Dieser Gewindefräser kann für Gewinde $\geq M12 \times 1,5$ ($M14 \times 1,5$, $M18 \times 1,5$ usw.) eingesetzt werden.

PROGRAMMIERUNG MIT Rprg

- Programmieren Sie für einfache Anpassungen der Gewindetoleranz immer mit einer Radius-Korrektur.
- Der Rprg-Wert ist der Startwert für einen neuen Fräser und ist am Schaft des Fräsers eingelasert. Das sollte im Werkzeugspeicher eingetragen werden.
- Rprg basiert auf der theoretischen Nulllinie des Gewindes. Das heißt, dass das Gewinde bei der Programmierung mit Rprg nie überdimensioniert, sondern normalerweise eng ist.
- Dadurch können Sie mit einer kleinen Änderung der Programmkoordinaten ein Gewinde in der erforderlichen Größe herstellen.

EMPFEHLUNGEN

- Verwenden Sie immer die korrekten Schneiddaten (siehe Schneiddatenüberblick auf Seite 198).
- Verwenden Sie den empfohlenen Kernlochdurchmesser, so wie bei konventionellen Gewindebohrern.
- Starten Sie für einfache Anpassungen der Gewindetoleranz immer mit dem Rprg-Wert, der am Schaft des Gewindefräasers eingelasert ist.
- Überprüfen Sie mit einer Messlehre die Toleranz am ersten Gewinde um zu ermitteln, ob der Radius korrigiert werden muss. Der Radius kann 2 oder 3 Mal korrigiert werden, bevor der Gewindefräser verschlissen ist.
- Bei der Trockenbearbeitung wird empfohlen, mit Pressluft zu arbeiten, um den Spanabtransport zu unterstützen.
- Beim Gewindegewindeschneiden von schwierigen Materialien wird empfohlen, den Vorgang in 2 oder 3 Arbeitsgängen durchzuführen.

GEWINDEBOHREN

ALLGEMEINE HINWEISE ZUM GEWINDEBOHREN

Der Erfolg jeder Gewindebohroperation hängt von einer Anzahl Faktoren ab, welche alle die Qualität des fertigen Produktes beeinflussen.

1. Die korrekte Geometrie des Gewindebohrers aufgrund des zu bearbeitenden Materials und des Bohrungstyps (z. B. Durchgangs- oder Grundlochbohrung) aus der Materialklassifizierungstabelle wählen.
2. Das Werkzeug muss fest eingespannt sein - Rundlauffehler können zu einer schlechten Qualität des Gewindes und im schlimmsten Falle zu einem Bruch des Gewindebohrers führen.
3. Auswahl der korrekten Bohrergröße aus den Tabellen der entsprechenden Katalogseite. Eine Materialverhärtungen des zu fertigenden Bauteils sollte immer minimal gehalten werden.
4. Die korrekte Schnittgeschwindigkeit aus der Produktseite im Katalog wählen.
5. Das passende Kühlschmiermittel für die Anwendung benutzen.
6. Bei NC-Anwendungen sollten die Vorschubwerte für das gewählte Programm korrekt sein. Beim Einsatz einer Gewindebohr-Vorrichtung sollte der Vorschub auf 95 % bis 97 % der Steigung gewählt werden, damit der Gewindebohrer ohne Druck ins Material läuft.
7. Wenn man mit einer Gewindeschneidvorrichtung mit Kupplung arbeitet, ist es sehr wichtig, dass der Gewindebohrer ohne Druck und Zug arbeitet. Bei höherem Drehmoment schaltet die Kupplung ab (z. B. bei Berührung des Bohrungsgrundes).
8. Der Gewindebohrer sollte mit einem gleichmäßigen Vorschub in die Bohrung einlaufen, da ein ungleichmäßiger Vorschub zu einer 'Gewindeflanken-Verschiebung' führen kann.

TABELLE ÜBER GEWINDEBOHRER-TOLERANZ GEGENÜBER TOLERANZ INNENGEWINDEN (MUTTER)

Toleranz-Klasse, Gewindebohrer			Toleranz, Innengewinde (Mutter)					Anwendung
ISO	DIN	ANSI BS						
ISO 1	4 H	3 B	4 H	5 H				Untermaß
ISO 2	6 H	2 B	4 G	5 G	6 H			Normalmaß
ISO 3	6 G	1 B			6 G	7 H	8 H	Übermaß
-	7 G	-				7 G	8 G	Übermaß für nachträgliche Oberflächen-Behandlung oder Beschichtung

FEHLERSUCHE BEIM GEWINDEBOHREN

PROBLEM	URSACHE	ABHILFE
Übermaß	Nicht korrekte Toleranz	Gewindebohrer mit einer engeren Gewindetoleranz wählen
	Nicht den korrekten Axialvorschub gewählt	Vorschubrate um 5-10 % verringern oder Anpressdruck der Gewindeschneidvorrichtung überprüfen
	Falscher Gewindebohrertyp für die Anwendung	Einen geradegenuteten Gewindebohrer mit Schälanschnitt für Durchgangsbohrung oder einen spiralgenuteten für Grundbohrungen benutzen. Eine Beschichtung am Werkzeug verhindert Aufbauschneidenbildung. Den Katalog oder den "Product Selector" für die entsprechende Werkzeugwahl nutzen.
	Gewindebohrer arbeitet nicht zentrisch	Halterung des Gewindebohrers überprüfen und das Zentrum des Gewindebohrers über der Bohrung positionieren
	Fehlende Schmierung	Gute Schmierung zur Vermeidung von Aufbauschneidenbildung verwenden. Siehe Schmiermittel Abschnitt im Technischen Handbuch.
	Gewindebohrergeschwindigkeit zu gering.	Den Empfehlungen im Katalog oder "Product Selector" folgen
Untermaß	Falscher Gewindebohrertyp für die Anwendung	Einen geradegenuteten Gewindebohrer mit Schälanschnitt für Durchgangsbohrungen oder einen spiralgenuteten für Grundbohrungen benutzen. Eine Beschichtung am Werkzeug verhindert Aufbauschneidenbildung. Gewindebohrer mit größerem Spiralwinkel verwenden. Den Katalog oder den "Product Selector" für die entsprechende Werkzeugwahl nutzen.
	Nicht korrekte Toleranz	Ein Gewindebohrer in einem höheren Toleranz-Feld sollte gewählt werden, besonders bei Material mit einer geringen Übermaß Tendenz, wie Gusseisen, Rostfreier Stahl
	Falsches oder fehlendes Schmiermittel	Gute Schmierung zur Vermeidung von Spanblockade in der Bohrung verwenden. Siehe Schmiermittel Abschnitt im Technischen Handbuch.
	Gewindekernbohrung zu eng	Bohrdurchmesser auf den maximalen Wert erhöhen. Mittels Kernlochtabelle prüfen.
	Zu enges Gewinde nach dem Gewindebohrvorgang	Den Empfehlungen für ein korrektes Werkzeug im Katalog oder "Product Selector" folgen
Ausbrüche am Werkzeug	Falscher Gewindebohrertyp für die Anwendung	Einen Gewindebohrer mit geringerem Spanwinkel benutzen. Einen Gewindebohrer mit einem längeren Anschnitt benutzen. Einen Gewindebohrer mit Schälanschnitt für Durchgangsbohrungen und einen spiralgenuteten für Sacklöcher benutzen, um Spanblockaden zu vermeiden. Den Katalog oder den "Product Selector" für eine korrekte Werkzeugalternative zu Rate ziehen.
	Falsches oder fehlendes Schmiermittel	Gute Schmierung zur Vermeidung von Aufbauschneidenbildung verwenden. Siehe Schmiermittel Abschnitt im Technischen Handbuch.
	Gewindebohrer berühren den Bohrungsgrund	Kernbohrungstiefe vergrößern oder Gewindebohrtiefe verringern
	Oberflächenverhärtung	Geschwindigkeit verringern, beschichtetes Werkzeug benutzen, gutes Schmiermittel verwenden. Siehe Abschnitt zur Bearbeitung von rostfreiem Stahl im Technischen Handbuch.
	Spanblockade beim Reversieren	Umschaltpunkt von Rechts- auf Linkslauf beachten
	Anschnitt trifft auf Bohrungskante	Aximale Position überprüfen und den Axialfehler verringern.
	Gewindekernbohrung zu eng	Bohrdurchmesser auf den maximalen Wert erhöhen. Mittels Kernlochtabelle prüfen.

FEHLERSUCHE BEIM GEWINDEBOHREN

PROBLEM	URSACHE	ABHILFE
Gewindebohrer-Bruch	Zu starker Verschleiß des Gewindebohrers	Neuen Gewindebohrer verwenden oder den alten nachschleifen
	Fehlende Schmierung	Gute Schmierung zur Vermeidung von Aufbauschneidenbildung und Spanblockierungen verwenden. Siehe Schmiermittel Abschnitt im Technischen Handbuch.
	Gewindebohrer berühren den Bohrungsgrund	Kernloch-Tiefe vergrößern oder Gewindebohrtiefe verringern
	Zu enges Gewinde nach dem Gewindebohrvorgang	Schnittgeschwindigkeit verringern. Den Empfehlungen im Katalog oder "Product Selector" folgen.
	Oberflächenverhärtung	Geschwindigkeit verringern, beschichtetes Werkzeug benutzen, gutes Schmiermittel verwenden. Siehe Abschnitt zur Bearbeitung von Rostfreien Stahl im Technischen Handbuch.
	Gewidekernloch zu eng	Bohrdurchmesser auf den maximalen Wert erhöhen. Siehe Kernlochtabellen
	Zu hohes Drehmoment	Gewindeschneidvorrichtung mit einstellbarer Drehmoment-Kupplung verwenden.
	Materialverschleiß nach dem Gewindebohren	Den Empfehlungen für ein korrektes Werkzeug im Katalog oder "Product Selector" folgen
Zu schneller Verschleiß	Falscher Gewindebohrertyp für die Anwendung	Gewindebohrer mit geringerem Spanwinkel und/oder stärkerem Drall und/oder längerem Anschnitt verwenden. Möglichst beschichtetes Werkzeug benutzen. Den Empfehlungen für ein korrektes Werkzeug im Katalog oder "Product Selector" folgen
	Fehlendes Schmiermittel	Gutes Schmiermittel verwenden um Aufbauschneidenbildung und thermische Belastung der Schneiden zu vermeiden. Siehe Schmiermittel Abschnitt im Technischen Handbuch.
	Gewindebohrergeschwindigkeit zu hoch	Schnittgeschwindigkeit verringern. Den Empfehlungen im Katalog oder "Product Selector" folgen.
Aufbau- schneidenbildung	Falscher Gewindebohrertyp für die Anwendung	Gewindebohrer mit geringerem Spanwinkel und/oder stärkerem Drall verwenden. Den Empfehlungen für ein korrektes Werkzeug im Katalog oder "Product Selector" folgen
	Fehlendes Schmiermittel	Ausreichende Schmierung verwenden um Aufbauschneiden zu vermeiden. Siehe Schmiermittel-Abschnitt im Technischen Handbuch.
	Oberflächenbehandlung ist nicht geeignet	Gewindebohrer mit geeigneter Oberflächenbehandlung wählen.
	Gewindebohrergeschwindigkeit zu gering	Folgen Sie den Empfehlungen des Katalogs oder "Product Selectors"

Fräsen

ALLGEMEINE HINWEISE ZUM FRÄSEN

Fräsen ist ein Bearbeitungsprozess, bei dem eine vorgegebene Menge Material durch einen sich relativ hochdrehenden Fräser mit einem entsprechenden Vorschub aus dem Werkstück entfernt wird.

Die charakteristische Eigenschaft des Fräsprozesses ist, dass jeder Zahn des Fräsers Material in Form von möglichst kleinen Spänen entfernt.

FRÄSER-TYPEN

Die drei grundlegenden Fräseroperationen werden unten gezeigt: (A) Abwälzfräsen, (B) Stirnfräsen und (C) Schafffräsen.

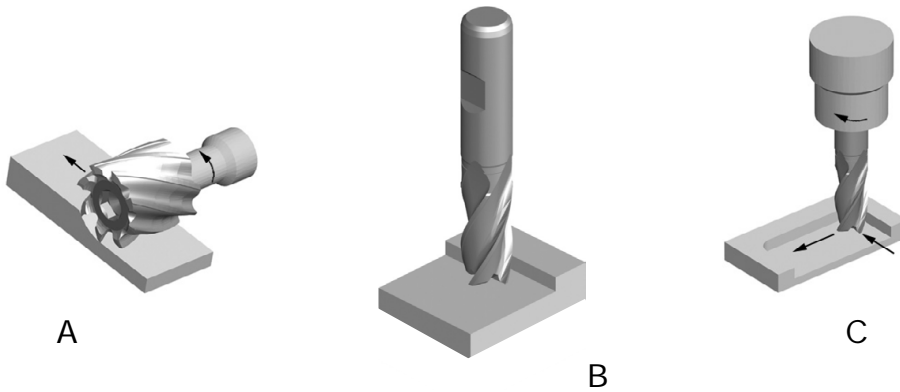

Beim Abwälzfräsen ist die Achse der Rotation parallel zur bearbeitenden Werkstückoberfläche ausgerichtet. Der Fräser hat eine Anzahl Zähne entlang des Kreisumfanges. Jeder Zahn agiert als Einzelschneide.

Fräser, die zum Abwälzfräsen genutzt werden, haben gerade oder spiralförmige Zähne. Beim Stirnfräsen wird der Fräser in eine Spindel aufgenommen.

Die Rotationsachse befindet sich senkrecht zur Werkstückoberfläche. Der Fräsvorgang wird durch die Stirnschneiden des Fräsers ausgeführt.

Beim Schafffräsen rotiert der Fräser entlang der Achse vertikal zur Werkstückoberfläche. Es kann auch geneigt werden, um schräge Oberflächen zu bearbeiten. Das Werkzeug schneidet seitlich und es hat eine Stirnverzahnung.

ANWENDUNGEN

Der Zerspanungsquerschnitt und die Anwendung sind stark voneinander abhängig. Für alle unterschiedlichen Anwendungen gibt es unterschiedliche Zerspanungsquerschnitte. Im neuen Dormer Katalog wurden die Anwendungen mit einfachen Symbolen gekennzeichnet. Folgende Bearbeitungen sind möglich:

Umfangfräsen	Stirnfräsen	Nutenfräsen	Eintauchen	Schräg eintauchen
Die radiale Frästiefe sollte kleiner als 0.25 x D des Schafffräsers sein.	Die radiale Frästiefe sollte nicht mehr als 0.9 x D, die axiale Tiefe nicht weniger als 0.1 x D entsprechen.	Nutenfräsen. Die radiale Tiefe der Nute sollte nicht größer als der Durchmesser des Fräsers sein.	Nur stirnschneidende Werkzeuge benutzen. Vorschub halbieren.	Sowohl axiale als auch radiale Bearbeitung des Werkstückes möglich.

FEHLERSUCHE BEIM FRÄSEN

PROBLEM	URSACHE	ABHILFE
Bruch	Zu grosser Zerspanungsquerschnitt	Vorschub pro Zahn verringern
	Zu grosser Vorschub	Vorschub verringern
Abnutzung	Nuten- oder Gesamtlänge zu gross	Kürzer einspannen oder kürzeren Schaftfräser verwenden
	Werkstück-Material zu hart	Katalog oder Selector verwenden, um ein verschleissfesteres Werkzeugmaterial oder eine geeignetere Beschichtung zu wählen
	Vorschub und Drehzahl nicht korrekt	Korrekte Bearbeitungsparameter aus dem Katalog oder Selector wählen
	Schlechte Spanentfernung	Auf gute Kühlschmierung achten
	Gegenlaufräsen	Gleichlaufräsen
	Ungeeigneter Drallwinkel	Eine korrekte Werkzeugalternative siehe Katalog oder Selector verwenden
Schneidkanten- ausbrüche	Vorschubrate zu hoch	Vorschubrate reduzieren
	Vibrationen	Drehzahl reduzieren
	Geringe Bearbeitungsgeschwindigkeit	Drehzahl erhöhen
	Gegenlaufräsen	Gleichlaufräsen
	Werkzeugstabilität	Kürzeres Werkzeug wählen und/oder Werkzeug kürzer spannen
	Werkstückstabilität	Werkstück besser spannen
Kurze Werkzeug- standzeit	Materialverhärtung	Katalog oder Selector für korrekte Werkzeugalternative durchsuchen
	Ungeeigneter Span- und Hinterschliffwinkel	Werkzeug mit passendem Spanwinkel wählen
	Zu hohe Reibung	Beschichtetes Werkzeug benutzen
Schlechte Oberflächen- qualität	Zu hoher Vorschub	Auf korrekter Drehzahl verringern
	Drehzahl zu gering	Drehzahl erhöhen
	Zu große Späne	Zerspanungsquerschnitt verringern
	Werkzeug Verschleiß	Werkzeug ersetzen oder nachschleifen
	Aufbauschneidenbildung	Zu einem Werkzeug mit höherem Drallwinkel wechseln
	Schlechte Spanabfuhr	Kühlmittelfluss vergrößern

PROBLEM	URSACHE	ABHILFE
Werkstück- ungenauigkeit	Werkzeugablenkung	Kürzeres Werkzeug wählen und/oder Werkzeug kürzer spannen
	Ungenügende Anzahl Nuten	Werkzeug mit mehr Zähnen verwenden
	Verschlissenes oder beschädigtes Spannfutter	Reparieren oder ersetzen
	Schlechte Spannfutterstabilität	Kürzeres oder stabileres Spannfutter verwenden
	Schlechte Stabilität der Spindel	Auf Stabilität der Spindel achten
Vibrationen	Vorschub und Geschwindigkeit zu hoch	Vorschub und Geschwindigkeit mit Hilfe des Katalogs oder Selectors korrigieren
	Nuten- oder Gesamtlänge zu groß	Kürzer einspannen oder kürzeren Schafffräser verwenden
	Frästiefe zu groß	Frästiefe verringern
	Ungenügende Stabilität von Maschine und Spannmittel	Spannmittel überprüfen und wenn nötig wechseln

HARTMETALL-FRÄSSTIFTE

ALLGEMEINE HINWEISE ZU HARTMETALL-FRÄSSTIFTEN

Frässtifte werden häufig für die Vorbereitung und das Schlichten von Komponenten aus verschiedensten Materialien genutzt.

Sie werden im Allgemeinen manuell verwendet und in einen druckluftbetriebenen Geradschleifer eingesetzt.

MERKMALE UND VORTEILE

Gehärtete Stahlschäfte erhöhen die Steifigkeit, senken die Gefahr des Verbiegens und reduzieren Vibrationen

Präzise geschliffene Schäfte verbessern den Halt und senken die Gefahr des Durchdrehens

Spezielle Lötelemente verhindern temperaturbedingte Ausfälle und erhöhen die Festigkeit und damit die Widerstandsfähigkeit gegen Druck und Stöße

Die universelle Doppelschnitt-Geometrie eignet sich für eine Vielzahl von Materialien und Anwendungen

Materialspezifische Geometrien, die sich für Stahl (ST), Edelstahl (VA), Aluminium (AL) und Glasfaser (GRP) eignen, sind ebenfalls erhältlich

Erhältlich mit TiAlN-Beschichtung zur Erhöhung der Werkzeugstandzeit bei abrasiven Werkstoffen

Kugelkopffräser werden mit Skip-Flute-Geometrie geschliffen

Damit wird eine aktive Geometrie in Richtung der Mitte des Fräasers realisiert, mit der die Schneidleistung optimiert und die Gefahr der Spanbildung und des Zusetzens verringert wird

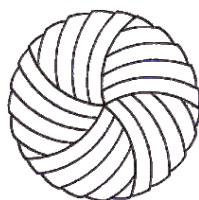

Skip

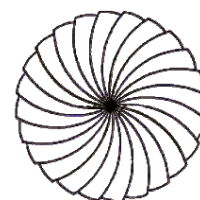

Normal

SICHERHEIT HAT VORRANG

Werkzeuge, die sich mit Hochgeschwindigkeit drehen, sind gefährlich und können bei falschem Gebrauch schwere Verletzungen verursachen.

Trennen Sie den Geradschleifer immer von der Druckluftversorgung, bevor Sie die Fräser wechseln.

Überprüfen Sie den Zustand des Geradschleifer und verwenden Sie nach Möglichkeit vibrationsarme Versionen.

Verwenden Sie immer geeignete Schutzausrüstung und stellen Sie sicher, dass auch Personen in der näheren Umgebung geschützt sind.



Es muss jederzeit persönliche Schutzausrüstung getragen werden.

EMPFEHLUNGEN

Verwenden Sie immer Geradschleifer mit der korrekten Nenndrehzahl.

Die regelmäßige Wartung von Geradschleifer ist wichtig; stellen Sie immer sicher, dass sie korrekt geölt und die Lager nicht ausgeschlagen sind.

Reinigen Sie beim Wechsel des Fräasers immer die Spannmutter, das Spannfutter und den Innenkegel des Geradschleifer.

Vermeiden Sie mechanische Schockbeanspruchungen und schwere Stöße gegen die Fräser.

Vermeiden Sie Temperaturschocks, indem Sie sicherstellen, dass der Fräser nicht überhitzt.

Lassen Sie den Fräser nicht zu tief in das Werkstück-Material eintauchen und verhindern Sie, dass der Fräser an Ecken oder in Kanälen eingeklemmt wird.

FEHLERSUCHE BEI DER VERWENDUNG VON FRÄSERN

PROBLEM	URSACHE
Ausbrechen von Fräserzähnen	Betrieb mit zu niedriger Drehzahl, kann Rückstoß verursachen
	Exzentrizität (Spindel, Spannfutter oder Lager verschlissen)
	Eintauchen in das Werkstück und Einklemmen des Fräasers im Werkstück
Verstopfen von Fräserzähnen	Nutlänge oder Gesamtlänge zu groß
	Auswahl der falschen Geometrie für das Werkstückmaterial
Vorzeitiger Verschleiß	Betrieb mit zu hoher Drehzahl für die Größe des Fräasers und das Werkstückmaterial
	Exzentrizität (Spindel, Spannfutter oder Lager verschlissen)
Kopf löst sich vom Schaft	Betrieb mit zu hoher Drehzahl, was zu einer Überhitzung führt
	Dauerbetrieb über einen langen Zeitraum, was zu einer Überhitzung führt

Nederlands		Hardheid	Treksterkte	ISO
Applicatie Materiaalgroepen (AMG)		HB	N/mm ²	
1. Staal	1.1 Automatenstaal, zachtstaal	< 120	< 400	P 1
	1.2 Constructiestaal, inzetstaal	< 200	< 700	P 1
	1.3 Koolstofstaal	< 250	< 850	P 2
	1.4 Gelegeerd staal	< 250	< 850	P 3
	1.5 Gelegeerd staal, gehard en ontlaten staal	> 250 < 350	> 850 < 1200	P 4
	1.6 Gelegeerd staal, gehard en ontlaten staal	> 350	> 1200 < 1620	H 1
	1.7 Gelegeerd staal, gehard	49-55HRC	> 1620	H 3
	1.8 Gelegeerd staal, gehard	55-63HRC	> 1980	H 4
2. Roestvast -staal	2.1 Roestvast automatenstaal	< 250	< 850	M 1
	2.2 Austenietisch	< 320	< 1100	M 3
	2.3 Ferritisch+Austenietisch, Martensietisch	< 300	< 1000	M 2
	2.4 Precipitatiehardend roestvast staal	>320 <410	>1100 <1400	S 2
3. Gietijzer	3.1 Gietijzer Lamellair	< 150	> 500	K 1
	3.2 Gietijzer Lamellair	> 150 <300	> 500 < 1000	K 2
	3.3 Nodulair gietijzer / Smeedbaar gietijzer	< 200	< 700	K 3
	3.4 Nodulair gietijzer / Smeedbaar gietijzer	> 200 < 300	> 700 < 1000	K 4
4. Titaan	4.1 Titaan, ongelegeerd	< 200	< 700	S 1
	4.2 Titaan, gelegeerd	< 270	< 900	S 2
	4.3 Titaan, gelegeerd	> 270 < 350	> 900 ≤ 1250	S 3
5. Nikkel	5.1 Nikkel, ongelegeerd	< 150	< 500	S 1
	5.2 Nikkel, gelegeerd	< 270	> 900	S 2
	5.3 Nikkel, gelegeerd	> 270 < 350	> 900 < 1200	S 3
6. Koper	6.1 Koper	< 100	< 350	N 3
	6.2 β-Messing, brons	< 200	< 700	N 4
	6.3 α-Messing	< 200	< 700	N 3
	6.4 Extra-sterk brons	< 470	< 1500	N 4
7. Aluminium Magnesium	7.1 Al, Mg, ongelegeerd	< 100	< 350	N 1
	7.2 Al gelegeerd, Si < 0.5%	< 150	< 500	N 1
	7.3 Al gelegeerd, Si > 0.5% < 10%	< 120	< 400	N 1
	7.4 Al gelegeerd, Si > 10% whisker versterkt Al-legeringen, Mg-legeringen	< 120	< 400	N 2
8. Kunststof	8.1 Thermoplasten	---	---	O
	8.2 Duraplasteren	---	---	O
	8.3 Versterkte kunststofmaterialen	---	---	O
9. Cermets	9.1 Cermets (metal-ceramics)	< 550	< 1700	H
	10. Grafiet	---	< 100	O

VOORBEELD VAN WERKSTUK MATERIAAL
IN VERSCHILLENDE SPECIFICATIES

AVMG	EN	W.N.	DIN	BS	SS	USA	UNS	ISO
1.1		1.1015, 1.1013	Rte60, Rte100	230M07, 050A12	1160	Leaded Steels	G12120	P1
1.2	EN 10 025 - S235JRG2	1.1012, 1.1053, 1.7131	S137-2, 16MnCr5, S150-2	060A35, 080M40, 4360-50B	1312, 1412, 1914	135, 30	G10100	P1
1.3	EN 10 025 - E295	1.1191, 1.0601	CK45, C60	080M46, 080A62	1550, 2142, 2172	1024, 1060, 1061	G10600	P2
1.4	EN 10 083-1 - 42 CrMo 4 - EN 10 270-2	1.7225, 1.3505, 1.6582, 1.3247	42CrMo4, 100Cr6, 34CrNiMo6, S2-10-1-8	708M40/42, 817M40, 554A99, BM2, BT42	1672-04, 2090, 2244-02, 2541-02	4140, A2, 4340, M42, M2	G41270, G41470, T30102, T11342	P3
1.5	EN ISO 4957 - HS6-5-2 - EN ISO 4957 - HS6-5-2-5	1.2510, 1.2713, 1.3247, 1.2080	100MnCrW12, 55NiCrMoV6, X210Cr12, S2-10-1-8	B01, BM2, BT42, 826 M40, 830M81	2244-04, 2541-03, 2550, 2722, 2723	01, L6, M42, D3, A2, M2, 4140, 8630	G86300, T30102 T11302, T30403, T11342	P4
1.6	EN ISO 4957 - HS2-9-1-8	1.2510, 1.2713, 1.3247, 1.2080	100MnCrW12, X210Cr12, S2-10-1-8	B01, 826 M40, 830M81	2244-05, 2541-05, , HARDOX 400	01, L6, M42, D3, 4140, 8130	T30403, G41400, J14047	H1
1.7	EN ISO 4957 - HS2-9-1-8	1.2510	100MnCrW4	BO1, BD3, BH13	HARDOX 500			H3
1.8	EN ISO 4957 - X40CrMoV5-1	1.3343, 1.2344	S6-5-2, GX40CrMoV5-1	BM2, BH13	2242 HARDOX 600			H4
2.1	EN 10 088-3 - X14CrMoS17	1.4305, 1.4104	X10CrNiS189, X12CrMoS17	303 S21, 416 S37	2301, 2312, 2314, 2346, 2380	303, 416, 430F	S30300, S41600, S43020	M1
2.2	EN 10 088-2,0 - 3 - 1.4301+AT	1.4301, 1.4541, 1.4571	X5CrNi189, X10CrNiMoTi1810	304 S15, 321 S17, 316 S, 320 S12	2310, 2333, 2337, 2343, 2353, 2377	304, 321, 316	S30400, S32100, S31600	M3
2.3	EN 10 088-3 - 1.4460	1.4460, 1.4512, 1.4582	XBCrNiMo275, X4CrNiMoN6257	317 S16, 316 S16	2324, 2387, 2570	409, 430, 436	S40900, S4300, S43600	M2
2.4	EN 1.4547	1.4547	X2CrNiMo20-18-6	HR41	2378	17-4PH	S31254	S2
3.1	EN 1561 - EN-JL1030	0.6010, 0.6040	GG10, GG40	Grade 150, Grade 400	0120, 0212, 0814	ASTM A48 class 20	F11401, F12801	K1
3.2	EN 1561 - EN-JL1050	0.6025, 0.6040	GG25, GG40	Grade200, Grade 400	0125, 0130, 0140, 0217	ASTM A48 class 60	F12801, F14101	K2
3.3	EN 1561 - EN-JL2040	0.7040, 0.7070, 0.8145, 0.8045	GGG40, GGG70, GTS45-06, GTW45-07	420/12, P4407, 700/2, 30g/72	0219, 0717, 0727, 0732, 0852	ASTM A220 grade 40010, ASTM A602 grade M4504	F22830, F20001	K3
3.4	EN 1561 - EN-JL2050	0.7040, 0.7070, 0.8145, 0.8045	GGG40, GGG70, GTS45-06, GTW45-07	420/12, P4407, 700/2, 30g/72	0221, 0223, 0737, 0854	ASTM A220 grade 90001, ASTM A602 grade M6501	F26230, 20005	K4
4.1		3.7024LN	Ti99.8	TA1 to 9	Ti99.8	ASTM B265 grade 1	R50250	S1
4.2		3.7164LN, 3.7119LN	TiAl6V4, TiAl5Sn2	TA10 to 14, TA17	TiAl6V4, TiAl5Sn2	AMS4928	R54790	S2
4.3		3.7164LN, 3.7174LN, 3.7184LN	TiAl6V4, TiAl6V5Sn2, TiAl4MoSn2	TA10 to 13, TA28	TiAl6V5Sn2	AMS4928, AMS4971	R56400, R54790	S3
5.1		2.4060, 2.4066	Nickel 200, 270, N699.6	NA 11, NA12	Ni200, Ni270	Nickel 200, Nickel 230	N02200, N02230	S1
5.2		2.4630LN, 2.4602, 2.4650LN	Nimonic 75, Monel 400, Hastelloy C, Inconel 600	HR203, 3027-76		Nimonic 75, Monel 400, Hastelloy, Inconel 600	N06075, N10002, N04400, N06600	S2
5.3		2.4668LN, 2.4631LN, 2.6554LN	Inconel 718, Nimonic 80A, Waspaloy	HR8, HR401, 601		Inconel 718, 625, Nimonic 80	N07718, N07080, N06625	S3
6.1	EN 1652 - CW004A	2.0060, 2.0070	E-Cu57, SE-Cu	C101	5010	101	C10100, C1020	N3
6.2	EN 1652 - CW612N	2.0380, 2.0360, 2.1030, 2.1080	CuZn39Pb2, CuZn40, CuSn8, CuSn6Zn	CZ120, CZ109, PB104	5168		C28000, C37710	N4
6.3	EN 1652 - CW508L	2.0321, 2.0260	CuZn37, CuZn28	CZ108, CZ106	5150		C2800, C27200	N3
6.4			Ampco 18, Ampco 25	AB1 type	5238, JM7-20			N4
7.1	EN 485-2 - EN AW-1070A	3.0255	A99.5	LMO, 1 B (1050A)	4005	EC, 1060, 1100	A91060, A91100	N1
7.2	EN 755-2 - EN AW-5005	3.1355, 3.3525	AlCuMg2, AlMg2Mn0.8	LM5, 10, 12, N4 (5251)	4106, 4212	380, 520.0, 520.2, 2024, 6061	A03800, A05200, A92024	N1
7.3	EN 1706 - EN AC-42000	3.2162.05, 3.2341.01	GD-ALSi8Cu, G-ALSi8Mg	LM2.4, 16, 18, 21, 22., 24, 25, 26, 27, L109	4244	319.0, 333.0, 319.1, 356.0	A03190, A03330, C35600	N1
7.4	SS-EN 1706 - EN AC-47000	3.2581.01	G-ALSi18, G-ALSi12	LM6, 12, 13, 20, 28, 29, 30	4260, 4261, 4262	4032, 222.1, A332.0	A94032, A02220, A13320	N2
8.1			Polystyrene, Nylon, PVC Cellulose, Acetate & Nitrate			Polystyrene, Nylon, PVC		O
8.2			Ebonite, Tufnol, Bakelite			Bakelite		O
8.3			Kevlar, Printed Circuit boards			Kevlar		O
9.1			Ferrotic, Ferrititanit					H
10.1			Graphite					O

		Vc															
m/Min		5	8	10	15	20	25	30	40	50	60	70	80	90	100	110	150
Feet/Min		16	26	32	50	66	82	98	130	165	197	230	262	296	330	362	495
Ø		RPM															
mm	inch																
1,00		1592	2546	3183	4775	6366	7958	9549	12732	15916	19099	22282	25465	28648	31831	35014	47747
1,50		1061	1698	2122	3183	4244	5305	6366	8488	10610	12732	14854	16977	19099	21221	23343	31831
2,00		796	1273	1592	2387	3183	3979	4775	6366	7958	9549	11141	12732	14324	15916	17507	23873
2,50		637	1019	1273	1910	2546	3183	3820	5093	6366	7639	8913	10186	11459	12732	14006	19099
3,00		531	849	1061	1592	2122	2653	3183	4244	5305	6366	7427	8488	9549	10610	11671	15916
3,18	1/8	500	801	1001	1501	2002	2502	3003	4004	5005	6006	7007	8008	9009	10010	11011	15015
3,50		455	728	909	1364	1819	2274	2728	3638	4547	5457	6366	7276	8185	9095	10004	13642
4,00		398	637	796	1194	1592	1989	2387	3183	3979	4775	5570	6366	7162	7958	8754	11937
4,50		354	566	707	1061	1415	1768	2122	2829	3537	4244	4951	5659	6366	7074	7781	10610
4,76	3/16	334	535	669	1003	1337	1672	2006	2675	3344	4012	4681	5350	6018	6687	7356	10031
5,00		318	509	637	955	1273	1592	1910	2546	3183	3820	4456	5093	5730	6366	7003	9549
6,00		265	424	531	796	1061	1326	1592	2122	2653	3183	3714	4244	4775	5305	5836	7958
6,35	1/4	251	401	501	752	1003	1253	1504	2005	2506	3008	3509	4010	4511	5013	5514	7519
7,00		227	364	455	682	909	1137	1364	1819	2274	2728	3183	3638	4093	4547	5002	6821
7,94	5/16	200	321	401	601	802	1002	1203	1604	2004	2405	2806	3207	3608	4009	4410	6013
8,00		199	318	398	597	796	995	1194	1592	1989	2387	2785	3183	3581	3979	4377	5968
9,00		177	283	354	531	707	884	1061	1415	1768	2122	2476	2829	3183	3537	3890	5305
9,53	3/8	167	267	334	501	668	835	1002	1336	1670	2004	2338	2672	3006	3340	3674	5010
10,00		159	255	318	477	637	796	955	1273	1592	1910	2228	2546	2865	3183	3501	4775
11,11	7/16	143	229	287	430	573	716	860	1146	1433	1719	2006	2292	2579	2865	3152	4298
12,00		133	212	265	398	531	663	796	1061	1326	1592	1857	2122	2387	2653	2918	3979
12,70	1/2	125	201	251	376	501	627	752	1003	1253	1504	1754	2005	2256	2506	2757	3760
14,00		114	182	227	341	455	568	682	909	1137	1364	1592	1819	2046	2274	2501	3410
14,29	9/16	111	178	223	334	446	557	668	891	1114	1337	1559	1782	2005	2228	2450	3341
15,00		106	170	212	318	424	531	637	849	1061	1273	1485	1698	1910	2122	2334	3183
15,88	5/8	100	160	200	301	401	501	601	802	1002	1203	1403	1604	1804	2004	2205	3007
16,00		99	159	199	298	398	497	597	796	995	1194	1393	1592	1790	1989	2188	2984
17,46	11/16	91	146	182	273	365	456	547	729	912	1094	1276	1458	1641	1823	2005	2735
18,00		88	141	177	265	354	442	531	707	884	1061	1238	1415	1592	1768	1945	2653
19,05	3/4	84	134	167	251	334	418	501	668	835	1003	1170	1337	1504	1671	1838	2506
20,00		80	127	159	239	318	398	477	637	796	955	1114	1273	1432	1592	1751	2387
24,00		66	106	133	199	265	332	398	531	663	796	928	1061	1194	1326	1459	1989
25,00		64	102	127	191	255	318	382	509	637	764	891	1019	1146	1273	1401	1910
27,00		59	94	118	177	236	295	354	472	589	707	825	943	1061	1179	1297	1768
30,00		53	85	106	159	212	265	318	424	531	637	743	849	955	1061	1167	1592
32,00		50	80	99	149	199	249	298	398	497	597	696	796	895	995	1094	1492
36,00		44	71	88	133	177	221	265	354	442	531	619	707	796	884	973	1326
40,00		40	64	80	119	159	199	239	318	398	477	557	637	716	796	875	1194
50,00		32	51	64	95	127	159	191	255	318	382	446	509	573	637	700	955

HV	HRC	HB		
Vickers	Rockwell	Brinell	N/ mm ²	Tons/ sq. in.
940	68			
900	67			
864	66			
829	65			
800	64			
773	63			
745	62			
720	61			
698	60			
675	59			
655	58		2200	142
650		618	2180	141
640		608	2145	139
639	57	607	2140	138
630		599	2105	136
620		589	2070	134
615	56	584	2050	133
610		580	2030	131
600		570	1995	129
596	55	567	1980	128
590		561	1955	126
580		551	1920	124
578	54	549	1910	124
570		542	1880	122
560	53	532	1845	119
550		523	1810	117
544	52	517	1790	116
540		513	1775	115
530		504	1740	113
527	51	501	1730	112
520		494	1700	110
514	50	488	1680	109
510		485	1665	108
500		475	1630	105
497	49	472	1620	105
490		466	1595	103
484	48	460	1570	102
480		456	1555	101
473	47	449	1530	99
470		447	1520	98
460		437	1485	96
458	46	435	1480	96
450		428	1455	94
446	45	424	1440	93
440		418	1420	92

HV	HRC	HB		
Vickers	Rockwell	Brinell	N/ mm ²	Tons/ sq. in.
434	44	413	1400	91
423	43	402	1360	88
413	42	393	1330	86
403	41	383	1300	84
392	40	372	1260	82
382	39	363	1230	80
373	38	354	1200	78
364	37	346	1170	76
355	36	337	1140	74
350		333	1125	73
345	35	328	1110	72
340		323	1095	71
336	34	319	1080	70
330		314	1060	69
327	33	311	1050	68
320		304	1030	67
317	32	301	1020	66
310	31	295	995	64
302	30	287	970	63
300		285	965	62
295		280	950	61
293	29	278	940	61
290		276	930	60
287	28	273	920	60
285		271	915	59
280	27	266	900	58
275		261	880	57
272	26	258	870	56
270		257	865	56
268	25	255	860	56
265		252	850	55
260	24	247	835	54
255	23	242	820	53
250	22	238	800	52
245		233	785	51
243	21	231	780	50
240		228	770	50
235		223	755	49
230		219	740	48
225		214	720	47
220		209	705	46
215		204	690	45
210		199	675	44
205		195	660	43
200		190	640	41

Tol	Ø mm							
	> 1 ≤ 3	> 3 ≤ 6	> 6 ≤ 10	> 10 ≤ 18	> 18 ≤ 30	> 30 ≤ 50	> 50 ≤ 80	> 80 ≤ 120
	µm							
e8	-14 / -28	-20 / -38	-25 / -47	-32 / -59	-40 / -73	-50 / -89	-60 / -106	-72 / -126
f6	-6 / -12	-10 / -18	-13 / -22	-16 / -27	-20 / -33	-25 / -41	-30 / -49	-36 / -58
f7	-6 / -16	-10 / -22	-13 / -28	-16 / -34	-20 / -41	-25 / -50	-30 / -60	-36 / -71
h6	0 / -6	0 / -8	0 / -9	0 / -11	0 / -13	0 / -16	0 / -19	0 / -22
h7	0 / -10	0 / -12	0 / -15	0 / -18	0 / -21	0 / -25	0 / -30	0 / -35
h8	0 / -14	0 / -18	0 / -22	0 / -27	0 / -33	0 / -39	0 / -46	0 / -54
h9	0 / -25	0 / -30	0 / -36	0 / -43	0 / -52	0 / -62	0 / -74	0 / -87
h10	0 / -40	0 / -48	0 / -58	0 / -70	0 / -84	0 / -100	0 / -120	0 / -140
h11	0 / -60	0 / -75	0 / -90	0 / -110	0 / -130	0 / -160	0 / -190	0 / -220
h12	0 / -100	0 / -120	0 / -150	0 / -180	0 / -210	0 / -250	0 / -300	0 / -350
k10	+40 / 0	+48 / 0	+58 / 0	+70 / 0	+84 / 0	+100 / 0	+120 / 0	+140 / 0
k12	+100 / 0	+120 / 0	+150 / 0	+180 / 0	+210 / 0	+250 / 0	+300 / 0	+350 / 0
m7	+2 / +12	+4 / +16	+6 / +21	+7 / +25	+8 / +29	+9 / +34	+11 / +41	+13 / +48
js14	+/- 125	+/- 150	+/- 180	+/- 215	+/- 260	+/- 310	+/- 370	+/- 435
js16	+/- 300	+/- 375	+/- 450	+/- 550	+/- 650	+/- 800	+/- 950	+/- 1100
H7	+10 / 0	+12 / 0	+15 / 0	+18 / 0	+21 / 0	+25 / 0	+30 / 0	+35 / 0
H8	+14 / 0	+18 / 0	+22 / 0	+27 / 0	+33 / 0	+39 / 0	+46 / 0	+54 / 0

1µm = 0.001mm

BOREN

ALGEMENE TIPS VOOR BOREN

1. Kies het beste type boor voor uw bewerking. Daarbij dienen het te boren materiaal, de mogelijkheden van de machine en de koeling in ogenschouw genomen te worden.
2. Instabiliteit van werkstuk en machine(spindel) kan schade aan het gereedschap tot gevolg hebben. Creëer altijd een stabiele opspanning. Dit kan ook worden bevorderd door de keuze van een zo kort mogelijke boor.
3. De houder waarin de boor moet worden opgespannen moet van een goede kwaliteit zijn. Als de boor in de houder slijpt en de voeding automatisch is kan de boor breken.
4. Gebruik de aanbevolen koel- en smeermiddelen om de levensduur van de boor te verlengen. Zorg ervoor dat voldoende koel- en smeermiddel bij de boorpunt komt.
5. Een goede spaanafvoer is van essentieel belang. Voorkom ten allen tijde dat spanen kunnen ophopen in de spiraalgroef.
6. Zorg bij het herslijpen van de boor dat de originele geometrie weer hersteld wordt en dat de boor voldoende geslepen wordt zodat alle slijtage weg is.

GATTOLERANTIE

Naarmate het gereedschapmateriaal, de geometrie en de oppervlaktebehandelingen verbeteren, is het mogelijk steeds nauwkeuriger gaten te boren. Normaal kan een standaard boor een gat boren met een H12 tolerantie. Nu kan met de huidige applicatie gereedschappen, onder de juiste omstandigheden H8 gehaald worden. Gattoleranties welke in het algemeen haalbaar zijn:

- HSS standaard boren – H12
- HSS / HSS-E Parabolische spaangroef diepgatboren – H10
- Volhardmetaal high performance gecoat bijv. – H8/H9

BEWERKINGSSTRATEGIE VOOR DIEPGATBOREN

Voor het boren van diepe gaten kunnen verschillende methodes toegepast worden om de gewenste diepte te bereiken. Onderstaand voorbeeld geeft vier manieren om een gat van 10xD te boren.

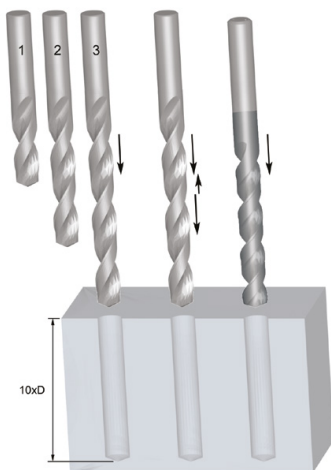

	Meerdere boren	Meerdere boren
Aantal gebruikte boren	3 (2,5xD, 6xD, 10xD)	2 (2,5xD, 10xD)
Type boor	Standaard geometrie, algemeen gebruik	Standaard geometrie, algemeen gebruik
+ / -	Duur Tijdrovend	Goedkoper Snel

	Lossend boren	Zonder te lossen boren
Aantal gebruikte boren	1 (10xD)	1 (10xD)
Type boor	Standaard geometrie, algemeen gebruik	Toepassingsgerichte boren
+ / -	Tijdrovend	Goedkoopst Snelst

PROBLEMEN EN OPLOSSINGEN BIJ BOREN

PROBLEEM	OORZAAK	OPLOSSING
Gebroken of gedraaide lip	Slecht contact tussen de morse conus en de spindel	Spindel en/of verloophulzen, opnames reinigen en beschadigingen verhelpen
Gespleten over de ziel van de boor	Te hoge voeding	Reduceer de voeding naar de juiste waarde
	Onvoldoende vrijloop	Herslijp volgens specificatie
	Ziel te veel uitgedund	Herslijp volgens specificatie
	Punt van de boor hard gestoten	Voorkom het stoten van de boorpunt. Let op met het plaatsen en verwijderen van morseconus boren
Versleten hoeken van de snijkant (de neus)	Te hoge snijsnelheid	Reduceer de snijsnelheid naar de juiste waarde – misschien kan de voeding verhoogd worden
Uitbreken van de hoeken van de snijkant	Onstabiliteit van het werkstuk	Verbeter de stabiliteit van het werkstuk
Afbrokkelen van de snijkant	Te grote vrijloop	Herslijp volgens specificatie
Breuk bij de uitloop van de spaangroef	Het vollopen van de spaangroef met spanen	Tijdig lossen of een diepgat boor toepassen
	De boor slijpt in de houder	Voorkom dat de boor kan slippen in de houder of spindel
Spiraalvormige vertekening in de wand van het gat	Onvoldoende voeding	Verhoog de voeding
	Slechte centreer werking van de boor	Gebruik een centreerboor om aan te centreren
Overmaat van het geboorde gat	Geen juiste puntgeometrie	Controleer of de boor juist herslepen is
	Onvoldoende spaanafvoer	Pas de snelheid, voeding of de diepte tussen het lossen aan om de spanen beter af te voeren

RUIMEN

ALGEMENE TIPS VOOR RUIMEN

Om de beste resultaten te bereiken met ruimen is het essentieel om ze te laten “werken”. Het is een veel voorkomende fout dat bij de voorbereiding van ruimen te weinig materiaal voor het ruimen wordt overgelaten. Daardoor zal de ruimer meer gaan wrijven of schrapen in plaats van snijden, waardoor er veel onnodige slijtage en afwijking van de gewenste diameter optreedt. Het is zeker zo belangrijk om niet teveel materiaal te laten staan, omdat dit ook de prestaties van de ruimer nadelig beïnvloedt. (Zie “Verspaand Volume” op de volgende pagina).

1. Selecteer het juiste type ruimer en de optimale voeding en snijsnelheid voor het te bewerken werkstuk. Zorg dat de voorgeboorde gaten de juiste diameter hebben.
2. Het werkstuk moet stabiel opgespannen zijn en de machine spil mag geen speling vertonen.
3. De opname waarin een ruimer met cilindrische schacht is opgespannen moet van goede kwaliteit zijn. Als de ruimer meedraait of slipt in de spantang tijdens een automatische voeding kan breuk van de ruimer het gevolg zijn.
4. Wanneer men een ruimer met een morseconus opspant in de bus, huls of de machinespil, gebruik dan altijd een hamer met een zachte kop. Zorg ervoor dat de morseconus en de bus, huls of machinespil schoon zijn en goed in elkaar passen, anders staat de ruimer uit het midden zodat overmaat een gevolg kan zijn.
5. Houd de uitsteeklengte van de ruimer ten opzichte van de machinespil zo kort mogelijk.
6. Gebruik aanbevolen smeermiddelen om de levensduur van de ruimer te bevorderen, en zorg dat het smeermiddel de snijkanten bereikt. Bij grijs gietijzer wordt, indien droogverspaand, perslucht aanbevolen.
7. Voorkom spaanophopingen in de spaangroeven van de ruimer.
8. Voordat de ruimer nageslepen wordt, moet men de rondloopnauwkeurigheid van de ruimer tussen de centers controleren. In veel voorkomende gevallen hoeft alleen de aansnijding geslepen te worden.
9. Houdt ruimers scherp. Regelmatig slijpen verzekert een economisch gebruik. Het is belangrijk te weten dat een ruimer slechts met de aansnijding snijdt en niet met de fasen. Daarom hoeft alleen deze kant herslepen te worden. Nauwkeurigheid van het slijpen is erg belangrijk voor de levensduur en de prestaties van het gereedschap.

VERSPANEND VOLUME

Het aanbevolen verspaand volume voor het ruimen is afhankelijk van het werkstuk-materiaal en de oppervlakte gesteldheid van het voorgeboorde gat. Algemene richtwaarden voor het verspaand volume zijn in de volgende tabellen weergegeven:

Diam. van het te ruimen gat (mm)	Voorgeboord	Voorgeboord met een opruimboor	Diam. van het te ruimen gat (inch)	Voorgeboord	Voorgeboord met een opruimboor
Minder dan 4	0.1	0.1	Minder dan 3/16	0.004	0.004
Van 4 t/m 11	0.2	0.15	3/16 t/m 1/2	0.008	0.006
Van 11 t/m 39	0.3	0.2	1/2 t/m 1 1/2	0.010	0.008
Van 39 t/m 50	0.4	0.3	1 1/2 t/m 2	0.016	0.010

TOLERANTIE



1. OP DE SNIJDENDE DIAMETER VAN STANDAARD RUIMERS

De diameter (d_1) wordt gemeten over het cilindrische deel vlak achter de aansnijding. De tolerantie is in overeenstemming met DIN 1420 en is bedoeld voor het produceren van gaten met een tolerantie van H7.

RUIMER TOLERANTIE			
Diameter (mm)		Tolerantie (mm)	
Van	t/m	Hoog +	Laag +
	3	0.008	0.004
3	6	0.010	0.005
6	10	0.012	0.006
10	18	0.015	0.008

RUIMER TOLERANTIE			
Diameter (mm)		Tolerantie (mm)	
Van	t/m	Hoog +	Laag +
	30	0.017	0.009
30	50	0.021	0.012
50	80	0.025	0.014

2. BIJ EEN H7 GAT

De meest voorkomende tolerantie voor een rond gat is H7 (zie tabel hieronder) Voor elke andere tolerantie kan de tabel en het model onder punt 3 gebruikt worden om de ruimer tolerantie en diameter te berekenen.

RUIMER TOLERANTIE			
Diameter (mm)		Tolerantie (mm)	
Van	t/m	Hoog +	Laag +
	3	0.010	0
3	6	0.012	0
6	10	0.015	0
10	18	0.018	0

RUIMER TOLERANTIE			
Diameter (mm)		Tolerantie (mm)	
Van	t/m	Hoog +	Laag +
	30	0.021	0
30	50	0.025	0
50	80	0.030	0

3. Wanneer men de afmetingen van een speciale ruimer wil bepalen, die in een bepaalde tolerantie moet snijden, b.v. D8, kan men de beproefde tabel hieronder gebruiken.

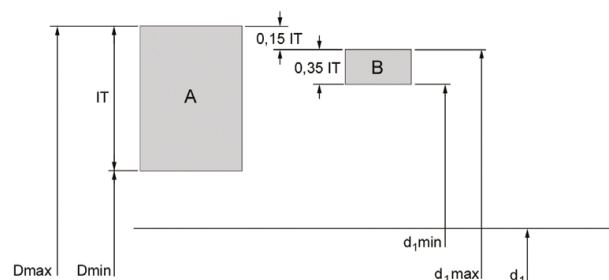

A = Gat tolerantie
 B = Ruimer tolerantie
 IT = Tolerantie bereik
 Dmax = Max. diameter van het gat
 Dmin = Min. diameter van het gat
 d_1 = Nominale diameter
 $d_{1,max}$ = Max. diameter van de ruimer
 $d_{1,min}$ = Min. diameter van de ruimer

Tolerantie bereik	Diameter tolerantie bereik								
	van 1 t/m 3	van 3 t/m 6	van 6 t/m 10	van 10 t/m 18	van 18 t/m 30	van 30 t/m 50	van 50 t/m 80	van 80 t/m 120	
IT5	4	5	6	8	9	11	13	15	
IT6	6	8	9	11	13	16	19	22	
IT7	10	12	15	18	21	25	30	35	
IT8	14	18	22	27	33	39	46	54	
IT9	25	30	36	43	52	62	74	87	
IT10	40	48	58	70	84	100	120	140	
IT11	60	75	90	110	130	160	190	220	
IT12	100	120	150	180	210	250	300	350	

Voorbeeld van een 10 mm gat met een D8 tolerantie,
 Maximum diameter van het gat = 10,062, Minimum diameter van het gat = 10,040, Gat tolerantie (IT8) = 0,022

Maximale tolerantie: $0,15 \times \text{gat tolerantie (IT8)} = 0,0033$, afgerond op 0,004
 Minimale tolerantie: $0,35 \times \text{gat tolerantie (IT8)} = 0,0077$, afgerond op 0,008

Maximale tolerantie voor de ruimer = $10,062 - 0,004 = 10,058$
 Minimale tolerantie voor de ruimer = $10,058 - 0,008 = 10,050$

PROBLEMEN / OORZAKEN / OPLOSSINGEN BIJ HET RUIMEN

PROBLEEM	OORZAAK	OPLOSSING
Gebroken of gedraaide lip	Onjuiste passing tussen schacht en opname	Zorg ervoor dat de schacht en de opname schoon en vrij van beschadigingen zijn.
Snelle slijtage	Te weinig verspaand volume	Verhoog het verspaand volume. Zie pag. 78-79.
Overmaats gat	Extreem hoogte verschil in snijkant diameter	Herslijp naar de juiste specificatie.
	Foutieve positie van de machinespindel	Repareer en herpositioneer de machine spindel.
	Beschadigingen aan de gereedschap-houder	Vervang de gereedschap-houder.
	Schacht van het gereedschap is beschadigd	Vervang het gereedschap of slijp de schacht.
	Onrondheid van het gereedschap	Vervang of herslijp het gereedschap.
	Assymetrische topaanschuining	Herslijpen naar de correcte specificatie.
Ondermaats gat	Te hoge voeding in verhouding tot de snijsnelheid.	Pas de snijwaarden aan volgens de snijgegevens in de Katalogus of de Product Selector.
	Onvoldoende hoeveelheid verspaand volume	Verhoog het verspaand volume. Zie pagina 78-79.
	Er wordt teveel hitte ontwikkeld tijdens het ruimen. Het gat krimpt en zet uit.	Vermeerder de koeling.
	De gereedschapidiameter is versleten en ondermaats	Herslijp tot correcte specificatie.
	Te lage voeding of snijsnelheid	Pas de snijwaarden aan volgens de snijgegevens in de Dormer Product Selector.
Ovale en conische gaten	Het voorgeboorde gat is te klein	Verminder de hoeveelheid verspaand volume. Zie pagina 78-79
	Foutieve positie van de machine spindel	Repareer en herpositioneer de machine spindel.
	Het gereedschap en het gat liggen niet in een lijn	Gebruik een opruimboor.
Slechte oppervlakte-gesteldheid van het gat	Asymmetrische topaanschuinhoek	Herslijp naar correcte specificatie.
	Overmatig verspaand volume	Verminder het verspaand volume. Zie pagina 78-79.
	Versleten gereedschap	Herslijp volgens specificatie.
	Te kleine snijkanthoek	Herslijp volgens specificatie.
	Te schrale emulsie of snijolie	Verhoog de concentratie.
	Snijnsnelheid en/of voeding te laag	Pas de waarden aan volgens de gegevens in de Katalogus of de Dormer Product Selector.
Het gereedschap klemt en breekt af	Snijnsnelheid te hoog	Pas de waarden aan volgens de gegevens in de Katalogus of de Dormer Product Selector.
	Versleten gereedschap	Herslijp volgens specificatie.
	De vrijloop van het gereedschap is te klein	Controleer en vervang het gereedschap, of pas het aan.
	De breedte van de fase is te groot	Controleer en vervang het gereedschap, of pas het aan.
	Het materiaal neigt tot klemmen	Gebruik een verstelbare ruimer om de tolerantie te compenseren.
	Het voorgeboorde gat is te klein	Verminder het verspaand volume.
Harde plekken in het te bewerken materiaal	Harde plekken in het te bewerken materiaal	Gebruik een volhardmetaal ruimer.

DRAADFREZEN

ALGEMENE ADVIEZEN VOOR DRAADFREZEN

1. Draadfrezen is een bewerking waarbij een frees met een specifiek schroefdraadprofiel aan de omtrek, door middel van een circulair interpolerende beweging schroefdraad aanbrengt in een boring of op een as.
2. Om draadfrezen te kunnen gebruiken is een CNC machine nodig die circulaire banen kan maken.
3. De meeste moderne CNC machines zijn voorzien van een draadrees cyclus.
4. Zie het handboek bij de machine of neem contact op met de leverancier.

KENMERKEN EN VOORDELEN

1. Draadfrezen hebben een hoge proceszekerheid en standtijd
2. Draadfrezen produceren kleine spaantjes die geen problemen geven in het proces
3. Aanpassingen in de tolerantie kunnen doorgevoerd worden middels aanpassing van de coördinaten
4. Er kan tot dicht op de bodem van een gat draad worden aangebracht
5. Geschikt voor het bewerken van een breed scala aan materialen
6. Een frees kan verschillende draadafmetingen maken binnen dezelfde spoed
7. Met dezelfde frees kan linkse en rechtse draad worden gemaakt
8. Enkele draadfrezen zijn voorzien van een verzinkkant om een aanschuiving te maken (J200, J205, J260)

KIES UW GEREEDSCHAP

Draadfrezen hebben een code waarin is opgenomen: het type, diameter (d_1) en spoed (P)

Met deze code kan de frees worden besteld

Raadpleeg altijd de catalogus om zeker te zijn van de juiste schroefdraadafmeting

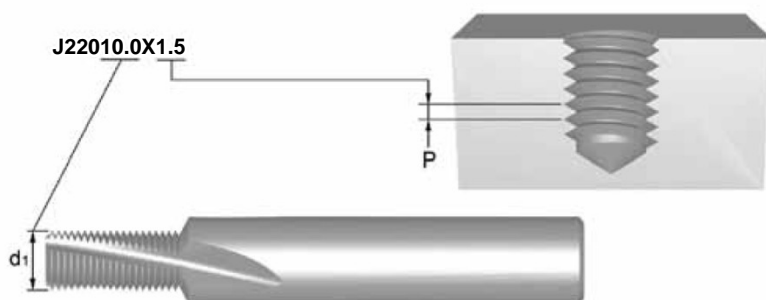

Deze schroefdraadfrees kan worden gebruikt voor schroefdraad \geq M12x1.5 (M14x1.5, M18x1.5 etc)

PROGRAMMEREN MET Rprg

- Voor eenvoudig aanpassen van de draadtolerantie altijd programmeren met radiuscompensatie
- De Rprg waarde is de startwaarde voor een nieuwe draadfrees en is te vinden op de schacht. Deze waarde dient ingevoerd te worden in de gereedschap bibliotheek.
- Rprg is gebaseerd op de theoretische nul-lijn van de draad, wat betekent dat wanneer je programmeert met deze Rprg waarde de schroefdraad nooit overmaats wordt maar zuiver passend.
- Hierdoor kan door middel van een minimale aanpassing van de coördinaten de gewenste schroefdraad tolerantie bereikt kan worden.

AANBEVELINGEN

- Pas altijd de correcte verspanings parameters toe
- Gebruik de aanbevolen voorboormaat, net zoals bij tappen.
- Voor het eenvoudig kunnen aanpassen van de draadtolerantie altijd starten met de Rprg waarde die vermeld wordt op de schacht van de draadfrees.
- Meet het eerste gat altijd na en pas de radiuscompensatie eventueel aan. Dit kan 2 tot 3 keer plaatsvinden voordat de frees echt versleten is.
- Bij droogverspanen is het aanbevolen om perslucht te gebruiken om de spanen weg te blazen.
- Bij het draadsnijden in moeilijke materialen is het beter om de draad in 2 of 3 stappen te frezen.

DRAADSNIJDEN

ALGEMENE TIPS BIJ HET TAPPEN

Het succes van de tapbewerking hangt van een aantal factoren af, die alle de kwaliteit van het tapgat beïnvloeden.

1. Gebruik de juiste tap overeenkomstig het te bewerken materiaal en het type gat, d.w.z. blind of doorlopend, overeenkomstig de "Materiaalclassificatie" tabel.
2. Verzeker u van een goede opspanning van het werkstuk – verschuiven van het stuk kan tapbreuk of slechte draadkwaliteit tot gevolg hebben.
3. Selecteer de correcte maat van de boor op de betreffende pagina van de catalogus. Sluit zoveel mogelijk zelfharding van het werkstuk uit.
4. Gebruik de juiste snijsnelheid zoals deze vermeld wordt op de pagina van de productcatalogus.
5. Gebruik de juiste snijolie.
6. Bij NC-toepassingen dient de geprogrammeerde voeding juist te zijn. Bij gebruik van een tapkop met lengtecompensatie moet men 95% tot 97% van de spoed gebruiken teneinde de tap de mogelijkheid te geven zijn eigen spoed te genereren.
7. Indien mogelijk kan men de tap het best opspannen in een tapkop van goede kwaliteit voorzien van een slipkoppeling, zodat vrije axiale beweging mogelijk is. De slipkoppeling kan de tap ook tegen breuk beschermen wanneer het draaimoment te hoog wordt of de tap per vergissing de bodem van het gat zou raken bij het tappen van een blind gat.
8. Zorg ervoor dat de tap soepel in het gat kan komen omdat een onregelmatige voeding in het begin van gat kan resulteren in spoedverschil.

VERGELIJKINGSTABEL VOOR TOLERANTIES VAN TAPPEN EN TOLERANTIES VOOR BINNENDRAAD (MOER)

Tolerantieklasse, Tap			Tolerantie, binnendraad (moer)					Gebruik
ISO	DIN	ANSI BS						
ISO 1	4 H	3 B	4 H	5 H				Passend zonder speling
ISO 2	6 H	2 B	4 G	5 G	6 H			Normale passing
ISO 3	6 G	1 B			6 G	7 H	8 H	Passend met speling
-	7 G	-				7 G	8 G	Losse passing alvorens behandeling of coating

PROBLEMEN OPLOSSEN BIJ HET DRAADSNIJDEN

PROBLEEM	OORZAAK	OPLOSSING
Overmaat	Foutieve tolerantie	Kies een tap met een kleinere tolerantie.
	Foutieve voeding	Verminder de voeding met 5 a 10% of gebruik een lengtecompensatie in de taphouder.
	Verkeerde tap voor de toepassing	Gebruik gecoate tappen om materiaal opbouw op de snijkant te vermijden. Raad-pleeg de catalogus of de 'product selector' om een correct alternatief te vinden.
	Tap staat niet in lijn met het gat	Controleer de taphouder en de tappositie tegenover het gat.
	Geen smering	Gebruik een goede smering om opbouw van de snijkant te vermijden. Zie hoofdstuk van smeermiddelen in het technisch handboek.
	Snijnsnelheid te laag	Gebruik de aanbevelingen in de catalogus / Product Selector.
Ondermaat	Verkeerde tap voor de toepassing	Gebruik een tap met schilaansnijding voor doorlopende gaten en een spiraaltap voor blinde gaten. Gebruik gecoate tappen om materiaal opgebouw op de snijkant te vermijden. Raad-pleeg de catalogus of de 'product selector' om een correct alternatief te vinden.
	Foutieve tolerantie	Kies een tap met een grotere tolerantie vooral in materialen die weinig tot geen overmaat vertonen zoals gietijzer en roestvaststaal.
	Foutieve of geen smering	Gebruik een goede smering om spaan-ophoping in het gat te vermijden. Zie ook het hoofdstuk aangaande smeermiddelen in het technisch handboek.
	Voorgeboord gat te klein	Vergroot de boordiameter tot het maximale toegestane. Meet na of het geboorde gat overeenkomt met de voorboormaat.
	Materiaal krimp na het tappen	Zie de catalogus/ productselector voor een goed alternatief.
Uitbrokkelen van de snijkant	Verkeerde tap voor de toepassing	Kies een tap met een kleinere spaanhoek. Kies een tap met een langere aansnijding. Gebruik spiraaltappen voor blinde gaten om te vermijden dat de spanen geblokkeerd geraken. Raadpleeg de catalogus of de productselector op alternatieve gereedschappen.
	Slechte of geen smering	Gebruik een goede smering teneinde materiaal opbouw op de snijkant. Zie ook het hoofdstuk 'smering' in het technisch handboek.
	Tap raakt de bodem van het gat	Vergoot de boordiepte of verminder de tapdiepte.
	Zelfhardend oppervlak	Verminder de snijnsnelheid, gebruik gecoat gereedschap, gebruik een goede smering. Zie het hoofdstuk aangaande het bewerken van roestvast staal in het technisch handboek.
	Spaan klemt bij het terugkeren	Vermijd het plotseling terugdraaien van de tap.
	Aansnijding botst op het begin van het gat	Controleer de axiale positie van de tap tegenover de positie van het gat.
	Voorboordiameter te klein	Vergroot de voorboordiameter tot het maximale toegestane. Meet na of het geboorde gat overeenkomt met de voorboormaat.

PROBLEMEN OPLOSSEN BIJ HET DRAADSNIJDEN

PROBLEEM	OORZAAK	OPLOSSING
Breuk	Tap is versleten	Gebruik een nieuwe tap of herslijp de versleten tap.
	Te weinig smering	Smeer voldoende teneinde materiaal opbouw op de snijkanten tegen te gaan. Zie het hoofdstuk 'smering en koeling' in het technisch handboek.
	Tap raakt de bodem van het gat	Vergoot de boordiepte of verminder de tapdiept.
	Snijsnelheid is te groot	Verminder de snijsnelheid. Raadpleeg de catalogus of de productselector.
	Zelfhardend oppervlakte van het materiaal	Verminder de snijsnelheid. Gebruik gecoate gereedschappen en een goede smering. Zie ook het hoofdstuk aangaande het bewerken van roestvast staal in het technisch handboek.
	Voorboordiameter te klein	Vergroot de voorboordiameter. Zie de aanbevelingstabel.
	Te groot koppel	Gebruik een tapopname met instelbare slipkoppeling.
	Materiaal krimpt na het tappen	Kijk in de catalogus of de productselector voor een alternatieve tap.
Weinig standtijd	Verkeerde tap voor de toepassing	Gebruik een tap met een kleinere spaanhoek en/of een grote vrijloophoek en/of een langere aansnijding. Gebruik gecoat gereedschap. Raadpleeg de catalogus of de productselector voor het selecteren van het juiste gereedschap.
	Te weinig smeren	Gebruik een goede smering teneinde materiaal opbouw en spanningen op de snijkant te voorkomen. Zie het hoofdstuk aangaande smering in het technisch handboek.
	Snijsnelheid te groot	Verminder de snijsnelheid. Volg de aanbevelingen in de catalogus of de productselector.
Materiaal opbouw	Verkeerde tap	Gebruik een tap met kleinere spaanhoek en/of een grotere vrijloop. Raadpleeg de catalogus of de productselector voor een goed alternatief.
	Te weinig smering	Gebruik een goede smering om materiaal opgebouw op de snijkant te voorkomen. Zie het hoofdstuk aangaande smering in het technisch handboek.
	Oppervlaktebehandeling is niet geschikt	Selecteer een tap die voorzien is met de aanbevolen oppervlaktebehandeling.
	Snijsnelheid is te laag	Volg de aanbevelingen in de catalogus of de productselector.

FREZEN

ALGEMENE ADVIEZEN VOOR FREZEN

Frezen is een bewerking waarbij met roterend gereedschap, eventueel in meerdere stappen, materiaal tot een opgegeven maat en oppervlaktekwaliteit wordt verspaant met een ten opzichte van het hoge toerental relatief langzame voeding.

De kenmerkende eigenschap van het freesproces is dat elke tand van de frees zijn deel van de hoeveelheid materiaal, in de vorm van kleine individuele spanen verwijdert.

TYPE FREESBEWERKINGEN

Er zijn, zoals hieronder getoond, in principe 3 soorten freesbewerkingen: (A) omtrek-frezen, (B) vlakfrezen en (C) vingerfrezen

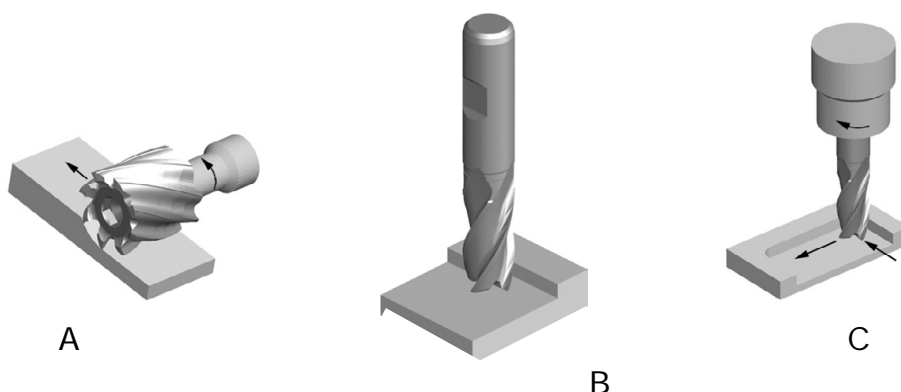

Bij omtrekfrezen ligt de hartlijn van de roterende frees parallel aan het werkstukoppervlakte. De tanden snijden elk afzonderlijk uitsluitend aan de omtrek of de mantel van de cilindrische frees, ook wel mantelfrees genoemd.

Omtrekfrezen kunnen zijn uitgevoerd met rechte of hellende tanden. De frezen met hellende tanden verspanen soepeler dankzij het geleidelijk ingrijpen en uitlopen van de tanden.

Bij vlakfrezen staat de hartlijn van de frees loodrecht op het te bewerken oppervlakte, waarbij de freesbreedte kleiner is als de freesdiameter. Voor het op deze manier verspanen van een werkstuk heeft een vlakfrees kop- en omtrek-tanden.

De term vingerfrezen, voor de bewerking en het gereedschap, is afgeleid van de manier waarop men het oppervlakte van een beslagen glasplaat met een vinger beschrijft. De vingerfrees beweegt zich op eenzelfde wijze door het werkstukoppervlakte waarbij verschillende contouren kunnen ontstaan. De bewerking wordt om die reden ook wel contourfrezen genoemd. Een vingerfrees is kop- en omtreksnijdend.

SPECIFIEKE BEWERKING

et spaanvolume en de specifieke bewerking zijn afhankelijk van elkaar. Elke specifieke bewerking heeft zo zijn eigen snediediepte, -breedte en voeding en daarmee dus ook een navenant hoger of lager spaanvolume. In de huidige Dormer Catalogus zijn simpele symbolen opgenomen waarmee wordt aangegeven welke specifieke bewerking men kan doen, te weten het frezen van:

Uitsparingen	Vlakken	Spiebanen	Gaten	Hellingen
De snedebreedte zal $<0.25xd$ moeten zijn.	De snedebreedte zal $<0.9xd$ en de snediediepte $<0.1xd$ moeten zijn.	Bij het frezen van spiebanen is de snedebreedte gelijk aan de diameter.	Met een centrum-snijdende frees kan men boren. De voeding v_f moet in dit geval gedeeld worden door het aantal tanden.	Tegelijk radiaal en axiaal het werkstuk binnen-dringen.

PROBLEMEN OPLOSSEN BIJ FREZEN

PROBLEEM	OORZAAK	OPLOSSING
Breuk	Te hoog spaanvolume	Verminder de voeding per tand
	Te hoge voeding	Verlaag de voeding
Slijtage	Snijkantlengte of de totale lengte is te lang	Kies een kortere frees en/of plaats de schacht verder in de houder
	Materiaal van het werkstuk is te hard	Selecteer een frees van het juiste materiaal en/of coating in de selector of de catalogus
	Onjuiste snijsnelheid en voeding	Controleer in de selector of catalogus de snijgegevens
	Slechte spaan afvoer	Verander de koelstralen van richting
	Tegenlopend frezen	Meelopend frezen
	Verkeerde spiraalhoek	Zoek in de selector of de catalogus naar een goed alternatief
Spaanvorming	Voeding te hoog	Verminder de voeding
	Trillingen	Verminder het toerental
	Lage snijsnelheid	Verhoog het toerental
	Tegenlopend frezen	Meelopend frezen
	Niet genoeg stabiliteit in de frees en opname	Kies een kortere frees en/of plaats de schacht verder in de houder
	Niet genoeg stabiliteit in de werkstukopspanning	Zet het werkstuk goed vast
Korte standtijd	Taai te bewerken materiaal	Zoek in de selector of catalogus naar een goed alternatief
	Foutieve spaanhoek en vrijloop	Wijzig de spaanhoek en vrijloop
	Wrijving van de frees/werkstuk	Gebruik een gecoate frees
Slechte oppervlakte-kwaliteit	Te hoge voeding	Verlaag voeding naar de juiste waarde
	Toerental te laag	Verhoog het toerental
	Happen in het materiaal	Verlaag het spaanvolume
	Frees slijtage	Vervang of herslijp de frees
	Opbouw aan de snijkant	Gebruik een frees met een grotere spiraalhoek
	Plakken van de spanen	Verhoog de hoeveelheid koelmiddelvoeistof

PROBLEEM	OORZAAK	OPLOSSING
Onnauw-keurig bewerkings-resultaat	Frees heeft te weinig snijkanten	Gebruik een frees met meer snijkanten
	Kies een kortere frees en/of plaats de schacht verder in de houder	Gebruik een frees met meer spaangroeven
	Versleten gereedschaphouder	Vervang of repareer de houder
	Niet genoeg stabiliteit in de gereedschaphouder	Vervang door een kortere gereedschaphouder
	Niet genoeg stabiliteit in de gereedschapspindel	Kies machine met grotere gereedschapspindel
Trilling	Voeding en toerental te hoog	Corrigeer de snijgegevens m.b.v. de selector of catalogus
	Totale – of snijkantlengte is te lang	Kies een kortere frees en/of plaats de schacht verder in de houder
	Te grote snedediepte	Verminder de snedediepte
	Niet genoeg stabiliteit in de werkstukopspanning	Controleer de gereedschaphouder, en vervang deze indien nodig

HARDMETALEN STIFFREZEN

ALGEMENE ADVIEZEN BIJ HARDMETALEN FREZEN

Hardmetalen stiffrezen worden breed ingezet voor het voor- en nabewerken in verschillende materialen.

Veelal worden ze toegepast in combinatie met luchtaangedreven machines.

KENMERKEN EN VOORDELEN

De taaie en geharde schacht verhogen de stabiliteit en verminderen de kans op trillingen en doorbuigen

De nauwkeurig geslepen schacht verbetert de opspanning en reduceert de kans op doorslippen

De speciale soldeermethode voorkomt het losraken van het snijdende gedeelte onder invloed van hoge temperaturen, hoge druk en stotende belasting

De dubbele vertanding is voor algemene toepassingen in vele materialen

Materiaal specifieke geometriën zijn er voor hoge productie in Staal (ST), Roestvaststaal (VA), Aluminium (AL) en vezel versterkte kunststoffen (GRP)

Leverbaar met TiAlN coating voor verhoogde standtijd in abrasieve materialen

Bolkopfrezen worden voorzien van een segment kopvertanding

Deze geometrie draagt eraan bij dat de frees snijdt tot op het hart waardoor het verspaningsproces verbeterd en er minder kans is op vollopen met spanen.

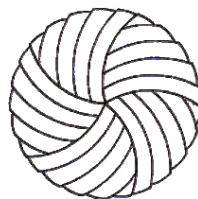

Segment

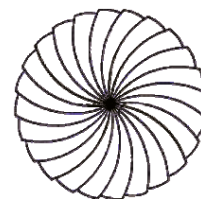

Normaal

SAFETY FIRST

Met hoge snelheid roterende gereedschappen zijn gevaarlijk wanneer niet correct toegepast

Voor het verwisselen van de frees altijd de machine loskoppelen van de perslucht

Controleer vooraf de conditie van de machine en kies bij voorkeur een trilling gedempte uitvoering

Gebruik altijd de bestemde persoonlijke beschermingsmiddelen en verzeker je ervan dat iedereen in de nabijheid afgeschermd is.



Persoonlijke beschermingsmiddelen dienen altijd gebruikt te worden

AANBEVELINGEN

- Pas altijd een machine met de juiste toerentalrange
- Regelmatig onderhoud aan de machine is van groot belang, check of ze gesmeerd zijn en de lagering intact is
- Reinig altijd de spanmoer, spantang en conus van de machine voordat de frees wordt gespannen
- Probeer mechanische schokken en klappen op de frees te vermijden
- Voorkom temperatuurschokken door de frees niet te heet te laten worden
- Laat de frees niet te diep het materiaal induiken om materiaalophopingen in bijvoorbeeld kanalen en hoeken te voorkomen

Probleemoplossingen bij GEBRUIK VAN STIFTFREZEN

PROBLEEM	OORZAAK
Versplinteren van de vertanding	Te laag toerental, kan stampen veroorzaken
	Slingeren (versleten spindel, spantang, lagering)
	Vasthechten van de spaan in het werkstuk
Vollopen van de tanden	Snijlengte of totale lengte is te lang
	Onjuiste geometriekeuze voor het werkstukmateriaal
Voortijdige slijtage	Te hoog toerental voor deze diameter of werkstukmateriaal
	Slingeren (versleten spindel, spantang, lagering)
De kop raakt los van de schacht	Te hoog toerental veroorzaakt oververhitting
	Te lang in gebruik kan oververhitting veroorzaken

Français		Dureté	Résistance à la traction	ISO
Groupes d'application Matière		HB	N/mm ²	
1. Acier	1.1 Acier doux magnétique	< 120	< 400	P 1
	1.2 Acier de construction, Acier de cémentation	< 200	< 700	P 1
	1.3 Acier au carbone ordinaire	< 250	< 850	P 2
	1.4 Acier allié	< 250	< 850	P 3
	1.5 Acier allié/ Acier trempé et revenu	> 250 < 350	> 850 < 1200	P 4
	1.6 Acier allié/ Acier trempé et revenu	> 350	> 1200 < 1620	H 1
	1.7 Acier allié trempé	49-55HRC	> 1620	H 3
	1.8 Acier allié trempé	55-63HRC	> 1980	H 4
2. Acier inoxydable	2.1 Acier inoxydable de décolletage	< 250	< 850	M 1
	2.2 Austénitique	< 320	< 1100	M 3
	2.3 Ferritique + Austénitique, Martensitique	< 300	< 1000	M 2
	2.4 Acier Inoxydable Trempé	>320 <410	>1100 <1400	S 2
3. Fonte	3.1 Graphite lamellaire	< 150	> 500	K 1
	3.2 Graphite lamellaire	> 150 <300	> 500 < 1000	K 2
	3.3 Graphite nodulaire/ Fonte malleable	< 200	< 700	K 3
	3.4 Graphite nodulaire/ Fonte malleable	> 200 < 300	> 700 < 1000	K 4
4. Titane	4.1 Titane, non-allié	< 200	< 700	S 1
	4.2 Titane, allié	< 270	< 900	S 2
	4.3 Titane, allié	> 270 < 350	> 900 ≤ 1250	S 3
5. Nickel	5.1 Nickel, non-allié	< 150	< 500	S 1
	5.2 Nickel, allié	< 270	> 900	S 2
	5.3 Nickel, allié	> 270 < 350	> 900 < 1200	S 3
6. Cuivre	6.1 Cuivre	< 100	< 350	N 3
	6.2 β-Laiton, Bronze	< 200	< 700	N 4
	6.3 α-Laiton	< 200	< 700	N 3
	6.4 Bronze, haute résistance	< 470	< 1500	N 4
7. Aluminium Magnésium	7.1 Al, Mg, non-allié	< 100	< 350	N 1
	7.2 Al allié, Si < 0.5%	< 150	< 500	N 1
	7.3 Al allié, Si > 0.5% < 10%	< 120	< 400	N 1
	7.4 Al allié, Si > 10% Alliages d'Al ou Mg, céramique renforcée	< 120	< 400	N 2
8. Matières synthétiques	8.1 Thermoplastiques	---	---	O
	8.2 Plastiques thermodurissables	---	---	O
	8.3 Plastiques renforcés	---	---	O
9. Matières dures	9.1 Cermets (céramiques métalliques)	< 550	< 1700	H
	10. Graphite	---	< 100	O

EXEMPLES DE MATIERES A USINER
SELON DIFFERENTES NORMES

AMG	EN	W.Nr.	DIN	BS	SS	USA	UNS	ISO
1.1	EN 10 025 - S235JRG2	1.1015, 1.1013	Rle60, Rle100	230M07, 050A12	1160	Leaded Steels	G12120	P 1
1.2	EN 10 025 - S235JRG2	1.1012, 1.1053, 1.7131	S137-2, 16MnCr5, S150-2	060A35, 080M40, 4360-50B	1312, 1412, 1914	135, 30	G10100	P 1
1.3	EN 10 025 - E295	1.1191, 1.0601	CK45, C60	080M46, 080A62	1550, 2142, 2172	1024, 1060, 1061	G10600	P 2
1.4	EN 10 083-1 - 42 CrMo 4 - EN 10 270-2	1.7225, 1.3505, 1.6582, 1.3247	42CrMo4, 100Cr6, 34CrNiMo6, S2-10-1-8	708M40/42, 817M40, 534A99, BM2, BT42	1672-04, 2090, 2244-02, 2541-02	4140, A2, 4340, M42, M2	G41270, G41470, T30102, T11342	P 3
1.5	EN ISO 4857 - HS6-5-2	1.2510, 1.2713, 1.3247, 1.2080	100MnCrW12, 55NiCrMoV6, X210Cr12, S2-10-1-8	801, BM2, BT42, 826M40, 830M31	2244-04, 2541-03, 2550, 2722, 2723	01, L6, M42, D3, A2, M2, 4140, 8630	G96300, T30102, T11302, T30403, T11342	P 4
1.6	EN ISO 4857 - HS2-9-1-8	1.2510, 1.2713, 1.3247, 1.2080	100MnCrW12, X210Cr12, S2-10-1-8	801, 826 M40, 830M31	2244-05, 2541-05, , HARDOX 400	01, L6, M42, D3, 4140, 8130	T30403, G41400, J14047	H 1
1.7	EN ISO 4857 - HS2-9-1-8	1.2510	100MnCrW4	BO1, BO3, BH13	HARDOX 500			H 3
1.8	EN ISO 4857 - X40CrMoV5-1	1.3343, 1.2344	S6-5-2, GX40CrMoV5-1	BM2, BH13	2242 HARDOX 600			H 4
2.1	EN 10 088-3 - X14CrMoS17	1.4305, 1.4104	X10CrNiS189, X12CrMoS17	303 S21, 416 S37	2301, 2312, 2314, 2346, 2380	303, 416, 430F	S30300, S41600, S43020	M 1
2.2	EN 10 088-2-0 - 3 - 1,4301+AT	1.4301, 1.4541, 1.4571	X5CrNiFe189, X10CrNiMoTi1810	304 S15, 321 S17, 316 S, 320 S12	2310, 2333, 2337, 2343, 2353, 2377	304, 321, 316	S30400, S32100, S31600	M 3
2.3	EN 10 088-3 - 1,4460	1.4460, 1.4512, 1.4582	X8CrNiMo275, X4CrNiMoN6257	317 S16, 316 S16	2324, 2387, 2570	409, 430, 436	S40900, S4300, S43600	M 2
2.4	EN 1,4547	1.4547	X2CrNiMo20-18-6	HR41	2378	17-4PH	S31254	S 2
3.1	EN 1561 - EN-JL1030	0.6010, 0.6040	GG10, GG40	Grade150, Grade 400	0120, 0212, 0814	ASTM A48 class 20	F11401, F12801	K 1
3.2	EN 1561 - EN-JL1050	0.6025, 0.6040	GG25, GG40	Grade200, Grade 400	0125, 0130, 0140, 0217	ASTM A48 class 40, STM A48 class 60	F12801, F14101	K 2
3.3	EN 1561 - EN-JL2040	0.7040, 0.7070, 0.8145, 0.8045	GGC40, GGG70, GTS45-06, GTW45-07	420/12, P4407, 700/2, 30g/72	0219, 0717, 0727, 0732, 0852	ASTM A220 grade 40010, ASTM A602 grade M4504	F22830, F20001	K 3
3.4	EN 1561 - EN-JL2050	0.7040, 0.7070, 0.8145, 0.8045	GGG40, GGG70, GTS45-06, GTW45-07	420/12, P4407, 700/2, 30g/72	0221, 0223, 0737, 0854	ASTM A220 grade 90001, ASTM A602 grade M8501	F26230, 20005	K 4
4.1		3.7024LN	T199 8	TA1 to 9	T199 8	ASTM B265 grade 1	R50250	S 1
4.2		3.7164LN, 3.7119LN	TiA6V4, TiA15Sn2	TA10 to 14, TA17	TiA6V4, TiA15Sn2	AMS4928	R54790	S 2
4.3		3.7164LN, 3.7174LN, 3.7184LN	TiA6V4, TiA16V5Sn2, TiA4MoSn2	TA10 to 13, TA28	TiA6V5Sn2	AMS4928, AMS4971	R56400, R54790	S 3
5.1		2.4060, 2.4066	Nickel 200, 270, N199 6	NA 11, NA12	Ni200, Ni270	Nickel 200, Nickel 230	N02200, N02230	S 1
5.2		2.4630LN, 2.4602, 2.4650LN	Nimonic 75, Monel 400, Hastelloy C, Inconel 600	HR203, 3027-76		Nimonic 75 Monel400, Hastelloy, Inconel600	N06075, N10002, N04400, N06600	S 2
5.3		2.4668LN, 2.4631LN, 2.6554LN	Inconel 718, Nimonic 80A, Waspaloy	HR8, HR401, 601		Inconel 718, 625, Nimonic 80	N07718, N07080, N06625	S 3
6.1	EN 1652 - CW004A	2.0060, 2.0070	E-Cu57, SE-Cu	C101	5010	101	C10100, C1020	N 3
6.2	EN 1652 - CW612N	2.0380, 2.0360, 2.1030, 2.1080	CuZn39PB2, CuZn40, CuSn8, CuSh6Zn	CZ120, CZ109/PB104	5168		C28000, C37710	N 4
6.3	EN 1652 - CW508L	2.0321, 2.0260	CuZn37, CuZn28	CZ108,CZ106	5150		C2600, C27200	N 3
6.4			Ampco 18, Ampco 25	AB1 type	5238, JM7-20			N 4
7.1	EN 485-2 - EN AW-1070A	3.0255	A199.5	LMO, 1 B (1050A)	4005	EC, 1060, 1100	A91060, A91100	N 1
7.2	EN 755-2 - EN AW-5005	3.1355, 3.3525	AlCuMg2, AlMg2Mn0.8	LM5, 10, 12, N4 (5251)	4106, 4212	380, 520.0, 520.2, 2024, 6061	A03800, A05200, A92024	N 1
7.3	EN 1706 - EN AC-42000	3.2162.05, 3.2341.01	GD-AISI80Cu, G-AISI5Mg	LM2,4,16,18,21,22,,24,25,26,27,L109	4244	319.0, 333.0, 319.1, 356.0	A03190, A03330, C35600	N 1
7.4	SS-EN 1706 - EN AC-47000	3.2581.01	G-AISI18, G-AISI12	LM6, 12,13, 20, 28, 29, 30	4260, 4261, 4262	4032, 222.1, A332.0	A94032, A02220, A13320	N 2
8.1				Polystyrene, Nylon, PVC Cellulose, Acetate & Nitrate		Polystyrene, Nylon, PVC		O
8.2				Ebonite, Tufnol, Bakelite		Bakelite		O
8.3				Kevlar, Primed Circuit boards		Kevlar		O
9.1				Ferrotic, Ferrotiltant				H
10.1				Graphite				O

Tableau des vitesses de coupe



		Vc															
m/Min		5	8	10	15	20	25	30	40	50	60	70	80	90	100	110	150
Feet/Min		16	26	32	50	66	82	98	130	165	197	230	262	296	330	362	495
Ø		RPM															
mm	inch																
1,00		1592	2546	3183	4775	6366	7958	9549	12732	15916	19099	22282	25465	28648	31831	35014	47747
1,50		1061	1698	2122	3183	4244	5305	6366	8488	10610	12732	14854	16977	19099	21221	23343	31831
2,00		796	1273	1592	2387	3183	3979	4775	6366	7958	9549	11141	12732	14324	15916	17507	23873
2,50		637	1019	1273	1910	2546	3183	3820	5093	6366	7639	8913	10186	11459	12732	14006	19099
3,00		531	849	1061	1592	2122	2653	3183	4244	5305	6366	7427	8488	9549	10610	11671	15916
3,18	1/8	500	801	1001	1501	2002	2502	3003	4004	5005	6006	7007	8008	9009	10010	11011	15015
3,50		455	728	909	1364	1819	2274	2728	3638	4547	5457	6366	7276	8185	9095	10004	13642
4,00		398	637	796	1194	1592	1989	2387	3183	3979	4775	5570	6366	7162	7958	8754	11937
4,50		354	566	707	1061	1415	1768	2122	2829	3537	4244	4951	5659	6366	7074	7781	10610
4,76	3/16	334	535	669	1003	1337	1672	2006	2675	3344	4012	4681	5350	6018	6687	7356	10031
5,00		318	509	637	955	1273	1592	1910	2546	3183	3820	4456	5093	5730	6366	7003	9549
6,00		265	424	531	796	1061	1326	1592	2122	2653	3183	3714	4244	4775	5305	5836	7958
6,35	1/4	251	401	501	752	1003	1253	1504	2005	2506	3008	3509	4010	4511	5013	5514	7519
7,00		227	364	455	682	909	1137	1364	1819	2274	2728	3183	3638	4093	4547	5002	6821
7,94	5/16	200	321	401	601	802	1002	1203	1604	2004	2405	2806	3207	3608	4009	4410	6013
8,00		199	318	398	597	796	995	1194	1592	1989	2387	2785	3183	3581	3979	4377	5968
9,00		177	283	354	531	707	884	1061	1415	1768	2122	2476	2829	3183	3537	3890	5305
9,53	3/8	167	267	334	501	668	835	1002	1336	1670	2004	2338	2672	3006	3340	3674	5010
10,00		159	255	318	477	637	796	955	1273	1592	1910	2228	2546	2865	3183	3501	4775
11,11	7/16	143	229	287	430	573	716	860	1146	1433	1719	2006	2292	2579	2865	3152	4298
12,00		133	212	265	398	531	663	796	1061	1326	1592	1857	2122	2387	2653	2918	3979
12,70	1/2	125	201	251	376	501	627	752	1003	1253	1504	1754	2005	2256	2506	2757	3760
14,00		114	182	227	341	455	568	682	909	1137	1364	1592	1819	2046	2274	2501	3410
14,29	9/16	111	178	223	334	446	557	668	891	1114	1337	1559	1782	2005	2228	2450	3341
15,00		106	170	212	318	424	531	637	849	1061	1273	1485	1698	1910	2122	2334	3183
15,88	5/8	100	160	200	301	401	501	601	802	1002	1203	1403	1604	1804	2004	2205	3007
16,00		99	159	199	298	398	497	597	796	995	1194	1393	1592	1790	1989	2188	2984
17,46	11/16	91	146	182	273	365	456	547	729	912	1094	1276	1458	1641	1823	2005	2735
18,00		88	141	177	265	354	442	531	707	884	1061	1238	1415	1592	1768	1945	2653
19,05	3/4	84	134	167	251	334	418	501	668	835	1003	1170	1337	1504	1671	1838	2506
20,00		80	127	159	239	318	398	477	637	796	955	1114	1273	1432	1592	1751	2387
24,00		66	106	133	199	265	332	398	531	663	796	928	1061	1194	1326	1459	1989
25,00		64	102	127	191	255	318	382	509	637	764	891	1019	1146	1273	1401	1910
27,00		59	94	118	177	236	295	354	472	589	707	825	943	1061	1179	1297	1768
30,00		53	85	106	159	212	265	318	424	531	637	743	849	955	1061	1167	1592
32,00		50	80	99	149	199	249	298	398	497	597	696	796	895	995	1094	1492
36,00		44	71	88	133	177	221	265	354	442	531	619	707	796	884	973	1326
40,00		40	64	80	119	159	199	239	318	398	477	557	637	716	796	875	1194
50,00		32	51	64	95	127	159	191	255	318	382	446	509	573	637	700	955

HV	HRC	HB	N/ mm ²	Tons/ sq. in.
Vickers	Rockwell	Brinell		
940	68			
900	67			
864	66			
829	65			
800	64			
773	63			
745	62			
720	61			
698	60			
675	59			
655	58		2200	142
650		618	2180	141
640		608	2145	139
639	57	607	2140	138
630		599	2105	136
620		589	2070	134
615	56	584	2050	133
610		580	2030	131
600		570	1995	129
596	55	567	1980	128
590		561	1955	126
580		551	1920	124
578	54	549	1910	124
570		542	1880	122
560	53	532	1845	119
550		523	1810	117
544	52	517	1790	116
540		513	1775	115
530		504	1740	113
527	51	501	1730	112
520		494	1700	110
514	50	488	1680	109
510		485	1665	108
500		475	1630	105
497	49	472	1620	105
490		466	1595	103
484	48	460	1570	102
480		456	1555	101
473	47	449	1530	99
470		447	1520	98
460		437	1485	96
458	46	435	1480	96
450		428	1455	94
446	45	424	1440	93
440		418	1420	92

HV	HRC	HB	N/ mm ²	Tons/ sq. in.
Vickers	Rockwell	Brinell		
434	44	413	1400	91
423	43	402	1360	88
413	42	393	1330	86
403	41	383	1300	84
392	40	372	1260	82
382	39	363	1230	80
373	38	354	1200	78
364	37	346	1170	76
355	36	337	1140	74
350		333	1125	73
345	35	328	1110	72
340		323	1095	71
336	34	319	1080	70
330		314	1060	69
327	33	311	1050	68
320		304	1030	67
317	32	301	1020	66
310	31	295	995	64
302	30	287	970	63
300		285	965	62
295		280	950	61
293	29	278	940	61
290		276	930	60
287	28	273	920	60
285		271	915	59
280	27	266	900	58
275		261	880	57
272	26	258	870	56
270		257	865	56
268	25	255	860	56
265		252	850	55
260	24	247	835	54
255	23	242	820	53
250	22	238	800	52
245		233	785	51
243	21	231	780	50
240		228	770	50
235		223	755	49
230		219	740	48
225		214	720	47
220		209	705	46
215		204	690	45
210		199	675	44
205		195	660	43
200		190	640	41

Tol	Ø mm							
	> 1 ≤ 3	> 3 ≤ 6	> 6 ≤ 10	> 10 ≤ 18	> 18 ≤ 30	> 30 ≤ 50	> 50 ≤ 80	> 80 ≤ 120
	µm							
e8	-14 / -28	-20 / -38	-25 / -47	-32 / -59	-40 / -73	-50 / -89	-60 / -106	-72 / -126
f6	-6 / -12	-10 / -18	-13 / -22	-16 / -27	-20 / -33	-25 / -41	-30 / -49	-36 / -58
f7	-6 / -16	-10 / -22	-13 / -28	-16 / -34	-20 / -41	-25 / -50	-30 / -60	-36 / -71
h6	0 / -6	0 / -8	0 / -9	0 / -11	0 / -13	0 / -16	0 / -19	0 / -22
h7	0 / -10	0 / -12	0 / -15	0 / -18	0 / -21	0 / -25	0 / -30	0 / -35
h8	0 / -14	0 / -18	0 / -22	0 / -27	0 / -33	0 / -39	0 / -46	0 / -54
h9	0 / -25	0 / -30	0 / -36	0 / -43	0 / -52	0 / -62	0 / -74	0 / -87
h10	0 / -40	0 / -48	0 / -58	0 / -70	0 / -84	0 / -100	0 / -120	0 / -140
h11	0 / -60	0 / -75	0 / -90	0 / -110	0 / -130	0 / -160	0 / -190	0 / -220
h12	0 / -100	0 / -120	0 / -150	0 / -180	0 / -210	0 / -250	0 / -300	0 / -350
k10	+40 / 0	+48 / 0	+58 / 0	+70 / 0	+84 / 0	+100 / 0	+120 / 0	+140 / 0
k12	+100 / 0	+120 / 0	+150 / 0	+180 / 0	+210 / 0	+250 / 0	+300 / 0	+350 / 0
m7	+2 / +12	+4 / +16	+6 / +21	+7 / +25	+8 / +29	+9 / +34	+11 / +41	+13 / +48
js14	+/- 125	+/- 150	+/- 180	+/- 215	+/- 260	+/- 310	+/- 370	+/- 435
js16	+/- 300	+/- 375	+/- 450	+/- 550	+/- 650	+/- 800	+/- 950	+/- 1100
H7	+10 / 0	+12 / 0	+15 / 0	+18 / 0	+21 / 0	+25 / 0	+30 / 0	+35 / 0
H8	+14 / 0	+18 / 0	+22 / 0	+27 / 0	+33 / 0	+39 / 0	+46 / 0	+54 / 0

1µm = 0.001mm

PERÇAGE

RECOMMANDATIONS GENERALES POUR LE PERÇAGE

1. Sélectionner le foret le plus approprié pour l'application, en gardant en mémoire le matériau à usiner, la capacité de la machine outil et l'huile de coupe utilisée.
2. La flexibilité entre la pièce et l'axe de la machine peut endommager le foret aussi bien que la pièce et la machine – il faut donc assurer un maximum de stabilité tout le temps. Ceci peut être amélioré en choisissant le foret le plus court possible pour l'application.
3. Le mandrin est un aspect important dans l'opération de perçage et le foret ne peut se permettre de casser ou de bouger du porte-outil.
4. Il est recommandé d'utiliser l'huile et les lubrifiants requis par l'opération de perçage. Lors de l'utilisation d'huiles ou de lubrifiants, il faut assurer un arrosage important, spécialement à la pointe du foret.
5. L'évacuation des copeaux durant le perçage est essentielle pour assurer une bonne opération de perçage. Ne jamais permettre aux copeaux de rester dans la goujure.
6. Lors du réaffûtage d'un foret, il faut toujours être sûr que la géométrie de pointe correcte est produite et que toute usure a été éliminée.

DIMENSION DE TROU

Plus les configurations de géométrie, de substrat et de revêtement sont avancées, plus la capacité d'un foret à produire un trou précis augmente. En général, un outil à géométrie standard produira un trou d'une tolérance H12. Cependant, étant donné que la configuration du foret devient plus complexe à la dimension du trou fini, dans des conditions favorables, peut se rapprocher de la tolérance H8. Pour offrir une plus grande précision, les types de produits et la tolérance des trous qu'ils réalisent sont listés ci-dessous :

- Forets HSS d'utilisation générale – H12
- Forets à goujure parabolique HSS / HSS-E pour trous profonds – H10
- Forets avec revêtement en carbure monobloc hautes performances – H8/H9

STRATEGIE DE PERÇAGE DE TROUS PROFONDS

Lors du perçage de trous profonds, il est possible d'utiliser différentes méthodes. L'exemple ci-dessous nous montre quatre possibilités de perçage de trous de 10 x le diamètre.

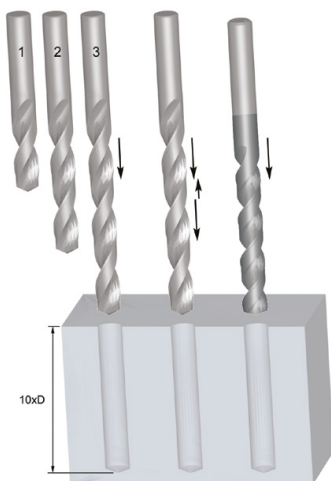

	Perçage en série	Perçage en série
No de forets	3 (2,5xD, 6xD, 10xD)	2 (2,5xD, 10xD)
Type de forets	Géométrie standard, utilisation générale	Géométrie standard, utilisation générale
+ / -	Coûteux Long	Plus rentable Rapide

	Perçage en plusieurs passes	Perçage en une seule passe
No de forets	1 (10xD)	1 (10xD)
Type de forets	Géométrie standard, utilisation générale	Outils d'utilisation spécifique
+ / -	Long	Rentable Rapide

PRESSION DE REFROIDISSEMENT INTERNE

Problème	Cause	Remède
Tenon cassé ou tordu	Mauvais contact entre la queue et le porte-outil	S'assurer du bon état de la queue et du porte-outil
Casse de l'âme	Avance trop élevée	Réduire l'avance à un taux optimum
	Dépouille initiale insuffisante	Réaffûter selon les spécifications correctes
	Amincissement de l'âme excessif	Réaffûter selon les spécifications correctes
	Lourd impact au niveau de la pointe du foret	Eviter tout impact au niveau de la pointe du foret. Faire attention lors de la mise en place ou de l'éjection des forets queue cône morse de l'axe
Usure des angles extérieurs	Vitesse excessive	Réduire la vitesse – peut-être augmenter l'avance
Casse des angles extérieurs	Pièce à usiner instable	Réduire le jeu de la pièce
Eclat des lèvres de coupe	Dépouille initiale excessive	Réaffûter selon les spécifications correctes
Casse de la goujure	Choc sur les goujures	Adopter un concept de perçage en plusieurs passes/ en série
	Glisse du foret	S'assurer que le foret est bien maintenu dans le mandrin et dans l'axe
Finition en spirale dans le trou	Avance insuffisante	Augmenter la vitesse de coupe
	Manque de précision dans le positionnement	Utiliser un foret de pré-perçage avant le perçage
Trou trop grand	Géométrie de pointe incorrecte	Vérifier la géométrie de pointe
	Mauvaise évacuation des copeaux	Ajuster la vitesse, l'avance et la longueur des passes pour obtenir une meilleure fragmentation des copeaux

ALESAGE

RECOMMANDATIONS GENERALES POUR L'ALESAGE

Pour obtenir les meilleurs résultats avec les alésoirs, il est important de les faire « travailler ». On fait souvent l'erreur de préparer les trous à aléser en y laissant une surépaisseur insuffisante. Si on ne laisse pas assez de surépaisseur dans le trou à aléser, le frottement entraîne une usure rapide de l'alésoir, avec pour conséquence une perte de diamètre. Pour de bons résultats, il est tout aussi important que la surépaisseur ne soit pas excessive. (Voir la section Enlèvement de matière ci-dessous).

1. Sélectionner le type d'alésoir le plus adapté ainsi que les conditions de vitesse de coupe et d'avance optimales pour l'application. Vérifiez que les trous percés ont un diamètre correct.
2. La pièce doit être maintenue de manière rigide et la broche de la machine ne doit pas avoir de jeu.
3. Le mandrin utilisé pour monter un alésoir à queue cylindrique doit être de bonne qualité. Si l'alésoir glisse dans le mandrin et si l'avance est automatique, l'alésoir risque de se casser.
4. Réduisez au minimum le porte-à-faux de l'outil par rapport à l'axe de la machine.
5. Utilisez les lubrifiants recommandés pour prolonger la durée de vie de l'alésoir et veillez à ce que le fluide atteigne toute les arêtes de coupe. Comme l'alésage n'est pas une opération de coupe difficile, une dilution 40:1 d'huile soluble convient généralement. De l'air comprimé peut être utilisé pour l'alésage à sec de la fonte grise.
6. Evitez le bourrage des copeaux dans les goujures d'un alésoir.
7. Avant d'affûter l'alésoir, vérifiez sa concentricité entre pointes. Dans la plupart des cas, seul le chanfrein d'entrée a besoin d'être réaffûté.
8. Veillez à ce que les alésoirs soient toujours bien affûtés. Un affûtage fréquent se justifie d'un point de vue économique, mais il ne faut pas oublier que les alésoirs ne coupent que sur le chanfrein et le cône d'entrée et non pas sur les listels de guidage. Par conséquent, seuls le chanfrein et le cône d'entrée doivent être réaffûtés. La précision de l'affûtage est importante tant pour la qualité du trou que pour la durée de vie de l'outil.

ENLEVEMENT DE SUREPAISSEUR

L'enlèvement de surépaisseur recommandé en alésage dépend du matériau de l'application et de la finition de surface du trou à aléser. Les recommandations de surépaisseur à enlever sont décrites dans les tableaux ci-dessous :

Diamètre du trou alésé (mm)	Sur avant trou au foret	Sur avant trou au foret alésoir	Diamètre du trou alésé (pouce)	Sur avant trou au foret	Sur avant trou au foret alésoir
En dessous de 3/16	0.1	0.1	En dessous de 3/16	0.004	0.004
De 4 à 11	0.2	0.15	3/16 à 1/2	0.008	0.006
De 11 à 39	0.3	0.2	1/2 à 1,1/2	0.010	0.008
De 39 à 50	0.4	0.3	1,1/2 à 2	0.016	0.010

ECARTS DE TOLERANCE



1. SUR LE DIAMETRE DE COUPE D'ALESOIRS STANDARD

Le diamètre se mesure sur le listel de guidage juste derrière le chanfrein ou le cône d'entrée. La tolérance selon la DIN 1420 est destinée à produire des alésages H7.

TOLERANCE DE L'ALESOIR			
Diamètre (mm)		Ecart de tolérance (mm)	
Supérieur	Jusqu'à et y compris	Elevé +	Faible +
	3	0.008	0.004
3	6	0.010	0.005
6	10	0.012	0.006
10	18	0.015	0.008

TOLERANCE DE L'ALESOIR			
Diamètre (mm)		Ecart de tolérance (mm)	
Supérieur	Jusqu'à et y compris	Elevé +	Faible +
	30	0.017	0.009
30	50	0.021	0.012
50	80	0.025	0.014

2. SUR UN ALESAGE H7

La tolérance la plus commune pour un trou fini est H7 (voir le tableau ci-dessous). Pour toute autre tolérance les données en dessous du point 3 peuvent être utilisées pour la calculer.

TOLERANCE DU TROU			
Diamètre (mm)		Ecart de tolérance (mm)	
Supérieur	Jusqu'à et y compris	Elevé +	Faible +
	3	0.010	0
3	6	0.012	0
6	10	0.015	0
10	18	0.018	0

TOLERANCE DU TROU			
Diamètre (mm)		Ecart de tolérance (mm)	
Supérieur	Jusqu'à et y compris	Elevé +	Faible +
	30	0.021	0
30	50	0.025	0
50	80	0.030	0

3. Lorsqu'il est nécessaire de définir les dimensions d'un alésoir spécial destiné à produire une tolérance spécifique, par ex. D8, utilisez la formule suivante :

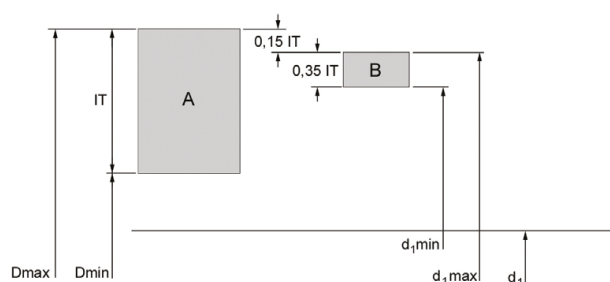

A = Tolerance du Trou
 B = Tolerance de l'alésoir
 IT = Amplitude de tolérance
 D_{max} = Diamètre de trou max
 D_{min} = Diamètre de trou min
 d₁ = Diamètre nominal
 d_{1,max} = Diamètre max de l'alésoir
 d_{1,min} = Diamètre min de l'alésoir

Amplitude de tolérance (microns)	Amplitude de tolérance du diamètre (mm)							
	de 1 à 3	de 3 à 6	de 6 à 10	de 10 à 18	de 18 à 30	de 30 à 50	de 50 à 80	de 80 à 120
IT5	4	5	6	8	9	11	13	15
IT6	6	8	9	11	13	16	19	22
IT7	10	12	15	18	21	25	30	35
IT8	14	18	22	27	33	39	46	54
IT9	25	30	36	43	52	62	74	87
IT10	40	48	58	70	84	100	120	140
IT11	60	75	90	110	130	160	190	220
IT12	100	120	150	180	210	250	300	350

par ex. trou de 10 mm avec une tolérance D8, diam. max. = 10,062, diam. min. = 10,040, tol. alésage (IT8) = 0,022

Diamètre maximal : 0,15 x tolérance de l'alésage (IT8) = 0,0033, soit = 0,004

Diamètre minimal : 0,35 x tolérance de l'alésage (IT8) = 0,0077, soit = 0,008

Diamètre maximal de l'alésoir = 10,062 - 0,004 = 10,058

Diamètre minimal de l'alésoir = 10,058 - 0,008 = 10,050

INTERRUPTIONS LORS DE L'ALEPAGE

Problème	Cause	Remède
Tenon cassé ou tordu	Mauvais contact entre la pince et la queue	S'assurer du bon état de la queue et de la douille
Usure rapide de l'outil	Enlèvement de matière insuffisant	Accroître la surépaisseur de matière
Trou surdimensionné	Variation excessive de la hauteur de lèvre	Réaffûter selon les spécifications correctes
	Jeu dans la broche de la machine	Réparer et rectifier l'axe
	Défaut du porte-outil	Remplacer le porte-outil
	Queue de l'outil endommagée	Remplacer ou réaffûter la queue
	Ovalisation de l'outil	Remplacer ou rectifier l'outil
	Angle de chanfrein d'entrée asymétrique	Réaffûter selon les spécifications correctes
	Avance ou vitesse de coupe trop élevées	Ajuster les conditions de coupe selon le catalogue
Trou sous dimensionné	Enlèvement de matière insuffisant	Accroître la surépaisseur de matière
	Trop de chaleur dégagée lors de l'alésage. Le trou s'élargit et se rétrécit	Accroître le flux d'huile
	Le diamètre de l'outil est détérioré et sous-dimensionné	Réaffûter selon les spécifications correctes
	Avance et vitesse de coupe trop faibles	Ajuster les conditions de coupe selon le catalogue
	Le trou de pré perçage est trop petit	Diminuer la surépaisseur de matière
Trous ovales et coniques	Jeu dans la broche de la machine	Réparer et rectifier l'axe
	Mauvais alignement entre l'outil et le trou	Utiliser un alésoir guide
	Angle de chanfrein d'entrée asymétrique	Réaffûter selon les spécifications correctes
Mauvaise finition de trou	Enlèvement de surépaisseur excessif	Diminuer la surépaisseur de matière
	Détérioration de l'outil	Réaffûter selon les spécifications correctes
	Angle de coupe trop faible	Réaffûter selon les spécifications correctes
	Huile de coupe ou émulsion trop diluée	Accroître le % de concentration
	Avance et/ou vitesse trop faibles	Ajuster les conditions de coupe selon le catalogue
	Vitesse de coupe trop élevée	Ajuster les conditions de coupe selon le catalogue
L'outil se bloque et casse	Détérioration de l'outil	Réaffûter selon les spécifications correctes
	La conicité arrière de l'outil est trop faible	Vérifier et remplacer / modifier l'outil
	Une dépouille trop grande	Vérifier et remplacer / modifier l'outil
	Le matériau de la pièce usinée a tendance à se resserrer	Utiliser un alésoir réglable pour compenser le jeu
	Le trou de pré perçage est trop petit	Diminuer la surépaisseur de matière
	Matériau hétérogène avec inclusions dures	Utiliser un alésoir en carbure monobloc

FRAISAGE PAR INTERPOLATION

RECOMMANDATIONS GENERALES POUR LE FRAISAGE PAR INTERPOLLATION

Le fraisage par interpolation est le procédé par lequel on crée un filetage par interpolation circulaire d'une fraise avec une géométrie spécifique de filetage usinée autour de sa périphérie.

Pour pouvoir utiliser une fraise à fileter, il faut disposer d'une machine CNC capable de suivre un chemin circulaire.

La plupart des machines CNC modernes sont dotées de cycles d'usinage pour le fraisage de filetages

Consulter le manuel ou prendre contact avec le fabricant de la machine pour tout complément d'information

CARACTÉRISTIQUES ET AVANTAGES

Le fraisage par interpolation permet d'accroître la fiabilité et la durée de vie de l'outil

Les fraises à fileter produisent des copeaux de petite taille et permettent ainsi de fileter sans problèmes

Tolérance très précise

Possibilité de fileter plus en profondeur, jusqu'au fond du trou

Capacité d'usinage dans un large éventail de matières

La même fraise peut produire des filetages de tailles différentes, à condition que le pas reste le même

Un seul et même outil pour les filets à droite et à gauche

Certaines fraises à fileter sont aussi capables d'usiner le chanfrein d'entrée (J200, J205, J260)

CHOISIR VOTRE OUTIL

Chaque fraise à fileter possède un code article basé sur le type, le diamètre (d_1) et le pas (P)

Le code article est le numéro à utiliser pour commander votre outil

Consulter systématiquement le catalogue pour être sûr que les dimensions du filetage sont correctes

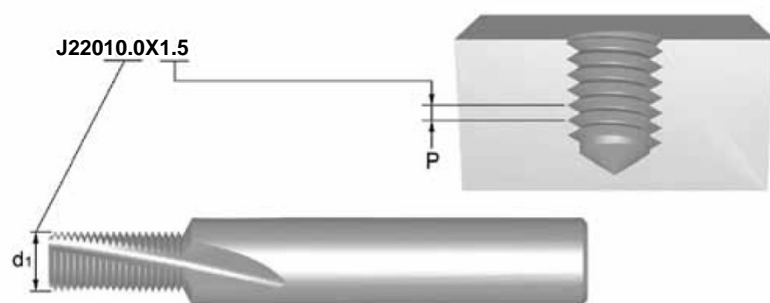

Cette fraise à fileter peut être utilisée pour les dimensions \geq M12x1,5 (M14x1,5, M18x1,5, etc)

PROGRAMMATION AVEC LA VALEUR Rprg

- Pour un réglage aisé de la tolérance de filet, utiliser toujours le programme avec correcteur de rayon
- La valeur Rprg est la valeur de départ de chaque nouvelle fraise, elle est gravée sur la queue. Elle doit être saisie dans la mémoire du correcteur d'outils
- La valeur Rprg est basée sur le zéro théorique du filet, avec pour conséquence que lorsque vous programmez avec elle, le filet n'est jamais surcoté, mais normalement serré
- Cela implique qu'il est possible d'obtenir le filetage à la taille voulue en ne modifiant que légèrement les coordonnées du programme

RECOMMANDATIONS

- Utiliser toujours les données de coupe correctes
- Utiliser la taille de foret recommandée pour le diamètre de taraud, comme pour les tarauds conventionnels
- Pour un réglage aisé de la tolérance de filet, toujours commencer avec la valeur Rprg gravée sur la queue de la fraise à fileter
- Utiliser un calibre pour vérifier la tolérance sur le premier filet afin d'établir si le rayon doit être corrigé. Le rayon peut être corrigé 2 ou 3 fois avant que la fraise à fileter ne soit usée
- En usinage à sec, il est recommandé d'aider à l'évacuation des copeaux avec de l'air comprimé
- Lorsque la matière est plus difficile à fileter, il est recommandé de travailler en 2 ou 3 passes

TARAUDAGE

RECOMMANDATIONS GENERALES POUR LE TARAUDAGE

Le succès de toute opération de taraudage est fonction d'un nombre de facteurs, chacun affectant la qualité du produit fini.

1. Sélectionner le type de taraud qui convient à la matière de la pièce et au type de trou, borgne ou débouchant, dans le tableau de classification des matériaux.
2. Veiller à la rigidité du bridage de la pièce, tout mouvement latéral pouvant causer la rupture du taraud ou la production d'un filetage de mauvaise qualité.
3. Sélectionner le diamètre de foret correct sur la page adéquate du catalogue. Veiller toujours à éviter autant que possible l'écrouissage de la pièce.
4. Sélectionner la vitesse de coupe correcte comme il est décrit sur la page produit du catalogue.
5. Utiliser le liquide de coupe adapté à l'application.
6. Sur les machines à commandes numériques, veiller à ce que le programme utilise une valeur de pas correcte. Avec un adaptateur de taraudage, utiliser 95 % à 97 % du pas pour permettre au taraud de générer son propre pas.
7. Si possible, utiliser un adaptateur de taraudage à limiteur de couple de bonne qualité, qui laisse le taraud libre de se déplacer dans le sens axial tout en garantissant sa perpendicularité par rapport au trou. Ces adaptateurs protègent également le taraud et évitent sa rupture s'il touche accidentellement le fond d'un trou borgne.
8. Veiller à la régularité de l'entrée du taraud dans le trou, car une avance irrégulière peut produire un évasement.

CORRESPONDANCE DES CLASSES DE TOLERANCE DU TARAUD ET DU FILETAGE INTERIEUR (ECROU)

Classe de tol. du taraud			Tolérance du filetage intérieur (Ecou)					Application
ISO	DIN	ANSI BS						
ISO 1	4 H	3 B	4 H	5 H				Ajustement sans tolérance
ISO 2	6 H	2 B	4 G	5 G	6 H			Ajustement normal
ISO 3	6 G	1 B			6 G	7 H	8 H	Ajustement avec une large tolérance
-	7 G	-				7 G	8 G	Ajustement lâche pour être suivi d'un traitement du revêtement

INTERRUPTIONS DURANT LE TARAUDAGE

Problème	Cause	Remède
Surcoté	Tolérance incorrecte	Choisir un taraud avec une tolérance de filet plus faible
	Taux d'avance axiale incorrect	Réduire le taux d'avance de 5 à 10% ou augmenter la compression du mandrin de taraudage
	Taux d'avance axiale incorrect	Utiliser une coupe gun pour les trous débouchants ou une goujure hélicoïdale pour les trous borgnes. Utiliser un taraud revêtu pour éviter les arêtes rapportés. Consulter le catalogue ou le Product Selector pour un bon choix d'outil.
	Le taraud n'est pas centré sur le trou	Vérifier le mandrin de taraudage et la position du taraud dans le trou.
	Manque de lubrification	Utiliser la bonne lubrification pour éviter les arêtes rapportées. Voir la section sur les lubrifiants dans le guide technique.
	Vitesse de taraud trop lente	Suivre les recommandations dans le catalogue/Product Selector.
Souscôté	Mauvais choix de taraud pour l'application	Utiliser une coupe gun pour les trous débouchants ou une goujure hélicoïdale pour les trous borgnes. Utiliser un taraud revêtu pour éviter les arêtes rapportés. Consulter le catalogue ou le Product Selector pour un bon choix d'outil.
	Tolérance incorrecte	Choisir un taraud avec une tolérance plus élevée, surtout dans les matières avec de faibles tendances au surcotage, telles que la fonte, l'acier inoxydable.
	Mauvais lubrifiant ou manque de lubrifiant	Utiliser une bonne lubrification afin d'éviter le blocage des copeaux dans le trou. Voir la section sur les lubrifiants dans le guide technique.
	Trou de perçage avant taraudage trop petit	Augmenter le diamètre du foret au maximum. Vérifiez le diamètre de perçage.
	Rétrécissement de la matière après taraudage	Voir les recommandations dans la Catalogue/Product Selector pour un bon choix d'outil.
Copeaux	Mauvais choix de taraud pour l'application	Utiliser une coupe gun pour les trous débouchants ou une goujure hélicoïdale pour les trous borgnes. Utiliser un taraud revêtu pour éviter les arêtes rapportés. Consulter le catalogue ou le Product Selector pour un bon choix d'outil.
	Mauvais lubrifiant ou manque de lubrifiant	Utiliser une bonne lubrification afin d'éviter les arêtes rapportées. Voir la section sur les lubrifiants dans le guide technique.
	Les tarauds heurtent le fond du trou	Augmenter la profondeur du perçage ou diminuer la profondeur du taraudage.
	Travail de surfaces difficiles	Réduire la vitesse, utiliser un outil revêtu, utiliser une bonne lubrification. Voir la section sur l'usinage de l'acier inoxydable dans le guide technique.
	Blocage des copeaux à l'inversion	Eviter un retour soudain du taraud à l'inversion.
	Le chanfrein heurte l'entrée du trou	Vérifier la position axiale et réduire l'erreur axiale de la pointe du taraud sur le centre du trou.
	Le trou de pré taraudage est trop petit	Augmenter le diamètre de perçage à la valeur maximale. Vérifiez le diamètre de perçage.

INTERRUPTIONS DURANT LE TARAUDAGE

Problème	Cause	Remède
Casse	Le taraud s'use	Utiliser un nouveau taraud ou réaffûter l'ancien.
	Manque de lubrifiant	Utiliser une bonne lubrification pour éviter les arêtes rapportées et le bourrage des copeaux. Voir la section sur les lubrifiants dans le guide technique.
	Les tarauds heurtent le fond du trou	Augmenter la profondeur du perçage ou diminuer la profondeur du taraudage.
	La Vitesse du taraud trop élevée	Réduire la vitesse de coupe. Suivre les recommandations du Catalogue/Product Selector.
	Travail de surfaces difficiles	Réduire la vitesse, utiliser un outil revêtu, utiliser une bonne lubrification. Voir la section sur l'usinage de l'acier inoxydable dans le guide technique.
	Trou de perçage avant taraudage trop petit	Augmenter le diamètre du foret au maximum. Voir le tableau.
	Couple trop élevée	Utiliser un attachement de taraudage ajustable.
	Rétrécissement de la matière après taraudage	Voir les recommandations du Catalogue/Product Selector pour un choix correct d'outil.
Usure rapide	Mauvais type de taraud pour l'application	Utiliser un taraud avec un angle de coupe plus faible et/ou un relief plus fort et/ou un chanfrein plus long. Utiliser un outil revêtu. Consulter le Catalogue/Product Selector pour sélectionner l'outil correct.
	Manque de lubrifiant	Utiliser une bonne lubrification afin d'éviter les arêtes rapportées ou l'usure thermique sur les arêtes de coupe dans le guide technique. Voir la section sur les lubrifiants.
	Vitesse du taraud trop élevée	Réduire la vitesse de coupe, Suivre les recommandations du Catalogue/Product Selector.
Arêtes de coupe rapportées	Mauvais type de taraud pour l'application	Utiliser un taraud avec un angle de coupe plus faible et/ou un relief plus fort. Consulter le Catalogue/Product Selector.
	Manque de lubrifiant	Utiliser une bonne lubrification afin d'éviter les arêtes rapportées. Voir la section sur les lubrifiants.
	Traitement de surface non adéquat	Choisir un taraud avec le traitement approprié.
	Vitesse de taraudage trop lente	Suivre les recommandations du Catalogue/Product Selector.

Fraisage

RECOMMANDATIONS GENERALES POUR LE FRAISAGE

Le fraisage est un procédé qui réalise un état de surface par enlèvement progressif d'une certaine quantité de matière de la pièce usinée à un taux de mouvement ou d'avance relativement faible par une fraise tournant à une vitesse comparativement élevée.

La caractéristique principale du procédé de fraisage est l'enlèvement de matière sous forme de copeaux individuels par chaque dent.

TYPES DE FRAISES

Les trois opérations de fraisage de base sont décrites ci-dessous : (A) fraisage périphérique, (B) fraisage en bout ou de surface, (C) fraisage de finition.

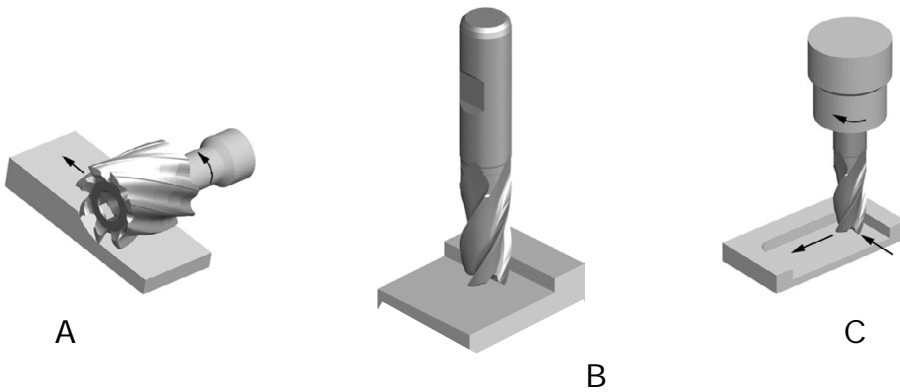

Lors du fraisage périphérique (également appelé dressage), l'axe de rotation de la fraise est parallèle à la surface de la pièce à usiner. La fraise a un certain nombre de dents autour de sa circonférence, chaque dent agissant en un seul point comme les outils coupants appelés fraises une taille.

Les fraises utilisées en fraisage périphérique peuvent avoir une denture droite ou hélicoïdale réalisant une action de coupe orthogonale ou oblique.

Lors du fraisage en bout, la fraise est montée sur une broche avec un axe de rotation perpendiculaire à la surface de la pièce usinée. La surface fraisée résulte d'une action des arêtes de coupe situées sur la périphérie ou le bout de la fraise.

Lors du fraisage de finition, la fraise tourne généralement sur un axe vertical de la pièce usinée. Les dents de coupe se situent à la fois sur le bout de la fraise et sur la périphérie du corps de la fraise.

APPLICATIONS

Le TEM et les applications sont extrêmement liés. Pour chaque type d'application il peut y avoir différents TEM qui augmentent selon l'engagement de la fraise dans la pièce usinée. Le Catalogue Dormer contient des icônes décrivant les différentes applications.

Contournage	Fraisage en bout	Rainurage	Fraisage en plongée	Ramping
La profondeur radiale de la coupe doit être inférieure à 0,25 du diamètre de la fraise.	La profondeur radiale de coupe ne doit pas dépasser 0,9 du diamètre, la profondeur axiale inférieure à 0,1 du diamètre.	Usinage d'une rainure de clavette. La profondeur radiale est égale au diamètre de la fraise.	Il est possible de percer la pièce usinée avec une fraise de finition en se servant simplement de la coupe au centre. Dans cette opération l'avance doit être divisée par deux.	Entrée à la fois axiale et radiale dans la pièce usinée.

PROBLÈMES LORS DU FRAISAGE

Problème	Cause	Remède
Casse	Enlèvement de copeaux trop important	Diminuer l'avance par dent
	Avance trop rapide	Diminuer l'avance
Usure	Longueur taillée ou totale trop importante	Utiliser une fraise plus courte
	Matière de la pièce usinée trop dure	Consulter le Catalogue ou le Selector pour trouver l'outil qui correspond à la matière ou avec le revêtement adéquat
	Mauvaises avance et vitesse	Consulter le Catalogue ou Selector pour trouver les paramètres corrects
	Faible évacuation des copeaux	Repositionner le lubrifiant
	Fraisage en opposition	Fraisage en avalant
	Mauvaise hélice de fraise	Consulter le Catalogue ou Selector pour trouver l'alternative correcte
Copeaux	Taux d'avance trop élevé	Réduire le taux d'avance
	Vibrations	Réduire le RPM
	Faible vitesse de coupe	Augmenter le RPM
	Fraisage en opposition	Fraisage en avalant
	Rigidité de l'outil	Choisir un outil plus court ou engager plus la queue dans le mandrin
	Rigidité de la pièce usinée	Maintenir la pièce fortement
Durée de vie courte	Matière travaillée résistante	Consulter le Catalogue ou Selector pour trouver l'alternative correcte
	Mauvais angle de coupe	Modifier l'angle de coupe
	Friction de la fraise/pièce usinée	Utiliser un outil revêtu
Mauvaise finition de surface	Avance trop élevée	Diminuer jusqu'à la vitesse correcte
	Vitesse trop faible	Augmenter la vitesse
	Petits copeaux	Diminuer l'enlèvement de copeaux
	Usure d'outil	Remplacer ou réaffûter l'outil
	Arête de coupe rapportée	Modifier l'hélice de l'outil
	Copeaux collants	Augmenter la quantité d'huile

Problème	Cause	Remède
Manque de précision de la pièce usinée	Déflexion de l'outil	Choisir un outil plus court ou engager davantage la queue dans le mandrin
	Nombre de dents insuffisant	Utiliser un outil avec plus de dents
	Usure du mandrin	Le réparer ou le remplacer
	Faible rigidité du mandrin	Utiliser un mandrin plus petit et/ou plus rigide
	Faible rigidité de la broche	Utiliser une broche plus large
Vibration	Avance et vitesse trop élevées	Corriger la vitesse et l'avance à l'aide du Catalogue ou Sélector
	Longueur taillée et totale trop importante	Enfoncer la queue dans le mandrin et utiliser une fraise plus courte
	Coupe trop profonde	Diminuer la profondeur de coupe
	Pas assez de rigidité	Vérifier le mandrin et le changer si nécessaire

FRAISES EN CARBURE

RECOMMANDATIONS GÉNÉRALES POUR LES FRAISES EN CARBURE

Les fraises en carbure sont couramment employées pour la préparation et la finition, dans les matières les plus variées.

Elles sont généralement utilisées à la main, montées dans une meuleuse pneumatique

CARACTÉRISTIQUES ET AVANTAGES

La queue en acier trempé et durci améliore la rigidité et réduit le risque de flexion ou de vibrations

La grande précision d'usinage de la queue améliore la qualité de serrage et réduit la probabilité de patinage

Les éléments spéciaux de brasage préviennent le bris à haute température et apportent par ailleurs une rigidité accrue pour supporter la pression et les chocs

La géométrie universelle à denture croisée convient aux matières et aux applications les plus variées

Des géométries spécialisées sont également disponibles spécifiquement pour l'acier (ST), l'inox (VA), l'aluminium (AL) et la fibre de verre (GRP)

Disponible avec revêtement au TiAlN pour accroître la longévité dans les matières abrasives

Les fraises à nez sphérique sont usinées avec une goujure à géométrie de type "Skip"

Géométrie active près du centre de la fraise, qui améliore l'action de coupe et réduit le risque d'agglomération des copeaux

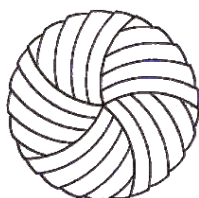

Skip

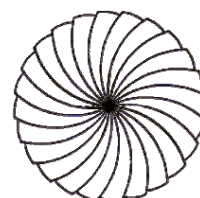

Normal

SÉCURITÉ PRIMORDIALE

Les outils qui tournent à haute vitesse sont dangereux et peuvent présenter des risques s'ils sont mal utilisés

Toujours déconnecter la meuleuse de l'alimentation en air comprimé avant d'entreprendre un changement de fraise

Contrôler l'état de la meuleuse et si possible, utiliser un modèle à faibles vibrations

Toujours utiliser un équipement de protection adapté et veiller à ce que toute personne travaillant à proximité soit également protégée



L'équipement de protection individuelle doit être porté en toutes circonstances.

RECOMMANDATIONS

- Toujours utiliser une meuleuse de vitesse nominale adaptée
- L'entretien périodique des meuleuses est important, contrôler qu'elles sont huilées et que les roulements ne sont pas usés
- Toujours nettoyer la pince et l'écrou de serrage, ainsi que le cône intérieur, à chaque changement de fraise
- Essayer d'éviter les chocs mécaniques et tout impact important sur les fraises
- Essayer d'éviter les chocs thermiques, en ne laissant pas la fraise surchauffer
- Ne pas plonger la fraise trop profondément dans la pièce, ni la coincer dans les angles ou les gorges

RÉSOLUTION DES PROBLÈMES LORS DE L'UTILISATION DES FRAISES

PROBLÈME	CAUSE
Écaillage de la denture de la fraise	Vitesse de travail trop lente, cause possible de rebond
	Excentricité (broche, pince ou roulements usés)
	Plongée et bourrage de la fraise dans la pièce
Colmatage de la denture de la fraise	Goujure trop longue ou longueur totale trop grande
	Choix incorrect de géométrie pour la matière à travailler
Usure prématurée	Vitesse de travail trop rapide pour la taille de fraise et la matière à travailler
	Excentricité (broche, pince ou roulements usés)
La tête se détache de la queue	Vitesse de travail trop rapide entraînant une surchauffe
	Période prolongée de travail entraînant une surchauffe

SIMPLY RELIABLE

Un professionista può giudicare la qualità del lavoro grazie ad un semplice esame del truciolo. Il nostro truciolo è pulito e di forma semplice e da solo racchiude in se' una storia. Il truciolo è il simbolo perfetto del nostro essere **Simply Reliable**.

De spaan is een duidelijke en ongecompliceerde vorm met een verhaal. Als professional kunt u de kwaliteit van het werk beoordelen door alleen te kijken naar de spaan. Het geeft een duidelijk en consistent signaal en dat is waarom we het gebruiken als een symbool voor het zijn van 'Simply Reliable'.

Der Fachmann erkennt die Qualität der Arbeit bereits bei der Betrachtung der Späne. Deshalb haben wir eine klare, schnörkellose Spanform als Logo gewählt. Dieser Span steht stellvertretend für die Spanformen, welche bei der Bearbeitung mit Einsatz unserer Produkte entstehen. Er spricht für sich und die hohe Zuverlässigkeit unserer Produkte. **Simply Reliable**.

Un copeau peut vous raconter une histoire de part sa forme et son fractionnement. En tant que professionnel, vous pouvez juger de la qualité d'un usinage rien qu'en le regardant. Le copeau envoie un message clair et évident, c'est pourquoi nous l'avons choisi comme symbole, **efficace tout simplement**.

Argentina

T: 54 (11) 6777-6777
F: 54 (11) 4441-4467
info.ar@dormerpramet.com

Austria

T: +31 10 2080 240
info.at@dormerpramet.com

Belgium & Luxembourg

T: +32 3 440 59 01
info.be@dormerpramet.com

Brazil

T: +55 11 5660 3000
info.br@dormerpramet.com

Canada

T: (888) 336 7637
En Français: (888) 368 8457
F: (905) 542 7000
cs.canada@dormerpramet.com

China

T: +86 21 2416 0508
info.cn@dormerpramet.com

Croatia

T: +385 98 407 489
info.hr@dormerpramet.com

Czech Republic

T: +420 583 381 111
F: +420 583 215 401
info.cz@dormerpramet.com

Denmark

T: 808 82106
info.se@dormerpramet.com

Finland

T: 0205 44 7003
info.fi@dormerpramet.com

France

T: +33 (0)2 47 62 57 01
F: +33 (0)2 47 62 52 00
info.fr@dormerpramet.com

Germany

T: +49 9131 933 08 70
F: +49 9131 933 08 742
info.de@dormerpramet.com

Hungary

T: +36-96 / 522-846
F: +36-96 / 522-847
info.hu@dormerpramet.com

India

T: +91 11 4601 5686
info.in@dormerpramet.com

Italy

T: +39 02 30 70 54 44
info.it@dormerpramet.com

Kazakhstan

T: +7 771 305 11 45
info.kz@dormerpramet.com

Mexico

T: +52 (555) 7293981
F: +52 (555) 7293981
cs.mexico@dormerpramet.com

Netherlands

T: +31 10 2080 240
info.nl@dormerpramet.com

Norway

T: 800 10 113
info.se@dormerpramet.com

Poland

T: +48 32 78-15-890
F: +48 32 78-60-406
info.pl@dormerpramet.com

Portugal

T: +351 21 424 54 21
info.pt@dormerpramet.com

Romania

T: +4(0)730 015 885
info.ro@dormerpramet.com

Russia

T: +7 (495) 775 10 28
Ф: +7 (499) 763 38 90
info.ru@dormerpramet.com

Slovakia

T: +421 (41) 764 54 60
F: +421 (41) 763 74 49
info.sk@dormerpramet.com

Slovenia

T: +385 98 407 489
info.si@dormerpramet.com

Spain

T: +34 935717722
info.es@dormerpramet.com

Sweden responsible for Iceland

T: +46 35 16 52 96
info.se@dormerpramet.com

Switzerland

T: +31 10 2080 240
info.ch@dormerpramet.com

Turkey

T: +90 533 212 45 47
info.tr@dormerpramet.com

Ukraine

T: +38 056 736 30 21
F: +38 067 220 97 48
info.ua@dormerpramet.com

Other countries

South America

T: +55 11 5660 3000
info.br@dormerpramet.com

Adria

T: +420 583 381 527
F: +420 583 381 401
info.rcee@dormerpramet.com

Rest of the World

Dormer Pramet International UK
T: +44 1246 571338
F: +44 1246 571339
info.int@dormerpramet.com

Dormer Pramet International CZ
T: +420 583 381 520
F: +420 583 215 401
info.int.cz@dormerpramet.com